

Symphony™ REF Series Undercounter Refrigerator

Order parts online
www.follettice.com

Installation, Operation and Service Manual

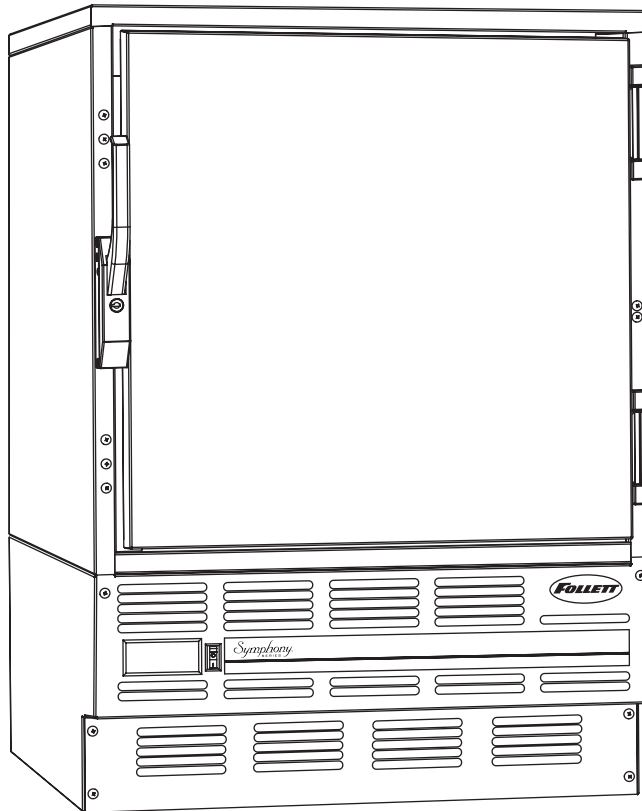

Following installation, please forward this manual
to the appropriate operations person.

FOLLETT
Cool Ideas For Ice Management

801 Church Lane • PO Box D, Easton, PA 18044, USA
Toll free (800) 523-9361 • (888) 2-FOLLETT
(610) 252-7301 • Fax (610) 250-0696 • www.follettice.com



00104109R06

**Follett Corporation
Equipment Return Policy**

Follett equipment may be returned for credit under the following conditions:

1. The equipment is new and unused.
2. A return authorization number has been issued by customer service.
3. Follett receives the equipment at the factory in Easton, PA within 30 days of the issue of the return authorization number.
4. The equipment must be returned in Follett packaging. If the packaging has been damaged or discarded, Follett will forward, at the customer's expense, new packaging.

Note: Return freight charges are the responsibility of the customer. If equipment is returned and is damaged because of improper packaging, Follett Corporation will not be held responsible.

Credit will be issued when:
The equipment has been inspected by Follett and deemed suitable to be returned to stock.

Note: A 15% restocking charge will be deducted from the credit. If the cost to return the product to stock exceeds 15%, the actual cost will be deducted.

Table of contents

Welcome to Follett	4
Before you begin	4
Specifications	4
Installation procedures	5
Stabilizer adjustment	5
Sealing the unit	5
Shelving adjustment	5
Reversing door	5
Changing the temperature set point	6
Operation	7
How the refrigerator works	7
Temperature control	7
Defrosting	7
Cleaning	7
Service information	8
Latch adjustment	8
Gasket replacement	8
Slide-out compressor tray	8
Wiring diagram	8
Refrigeration system diagram	9
Troubleshooting guide	10
Accessory information	11
Temperature alarm	11
Pyxis	12
Replacement parts	13

Welcome to Follett

Follett equipment enjoys a well-deserved reputation for excellent performance, long-term reliability and outstanding after-the-sale support. To ensure that this product delivers that same degree of service, we ask that you take a moment to review this manual before beginning the installation. Should you have any questions or require technical help at any point, please call our technical service group at (800) 523-9361, (888) 2-FOLLETT or (610) 252-7301.

Before you begin

After uncrating and removing all packing material, inspect the equipment for concealed shipping damage. If damage is found, notify the shipper immediately and contact Follett Corporation so that we can help in the filing of a claim, if necessary.

Specifications

Series specifications

REF4-ADA	31.5" height	fits below 34" high ADA-compatible counter	4.0 cu ft capacity
REF5	34.5" height	fits below standard 36" high counter	4.8 cu ft capacity

Electrical specifications

115V, 60Hz, 1 phase
Full load amps: 8.0
Minimum circuit ampacity: 15 amp
Maximum size of branch circuit overcurrent device: 15 amp

Refrigeration specifications

Refrigerant – R404A
Charge size – 8 oz
Maximum design pressures:
 High side – 375psi
 Low side – 174psi

Installation specifications

Ambient temperature must not exceed 100°F (38°C).
The front louvered panel must be kept free of any cabinet trim or obstructions to assure proper ventilation of the refrigeration system.



Important cautions

Equipment must be wired according to local and NEC codes.

Always disconnect power before servicing refrigerator.

Installation

Stabilizer adjustment

Leveling the unit is important to the proper operation of the refrigeration system. After the refrigerator is positioned in the desired mounting location, remove the lower front panel to access the stabilizer legs on the base of the unit. The refrigerator is shipped with the stabilizer legs in the fully retracted position. They may be adjusted independently by turning clockwise to lower, or counterclockwise to raise the stabilizer leg.

Sealing the unit

Once unit is in the final location, apply a thick bead (minimum 1/4" (6mm) diameter) of NSF-listed silicone sealant (Dow Corning RTV-732 or equivalent) to the base of the unit, sealing it to the floor.

Shelving adjustment

The epoxy-coated wire shelves may be adjusted in .5" increments.

1. Remove shelf.
2. Remove each shelf bracket by applying pressure and lifting bottom tab up and out of pilaster.
3. Insert each shelf bracket in new location by inserting top curved tab and applying pressure while inserting lower tab.
4. Reinsert shelf.

Reversing door

1. Remove screws from latch assembly (Fig. 1).
2. Carefully remove hinge covers with a flat screwdriver (Fig. 2A).
Note: Use caution to avoid scratching covers with screwdriver.
3. Remove screws from hinges while supporting door (Fig. 2B).
4. Remove plugs from identical hinge holes on reverse side of cabinet.
5. Reverse door and mount hinges by reinserting screws.
6. Fill holes from original hinge location with plugs removed from other side.
7. Mount latch by reinserting screws.
8. Remove screws from handle assembly (Fig. 3A).
9. Rotate handle to the upright position (Fig. 3B).
10. Mount handle by reinserting screws.

Fig. 1

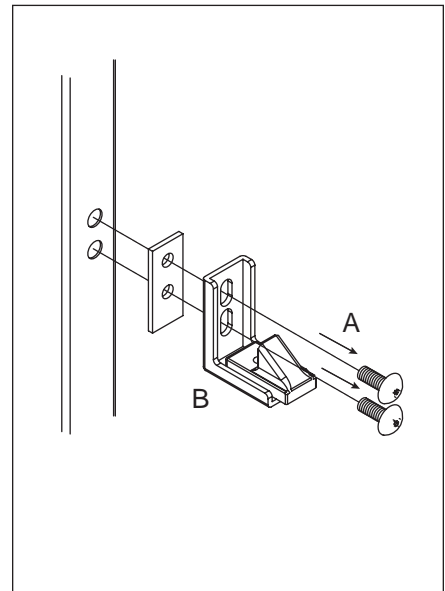

Fig. 2

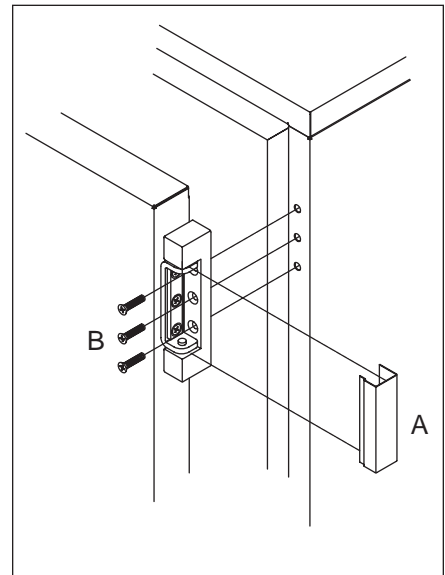
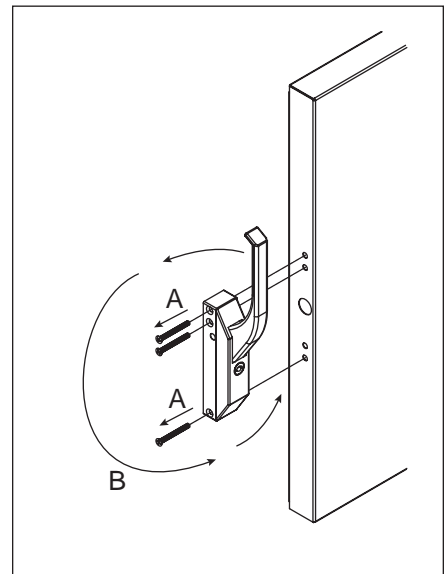

Fig. 3



Changing the temperature set point

Follett sets the temperature controller to a 38°F set point. This set point may not deliver the temperature range desired for your specific application. For example, some medicine manufactures suggest a storage temperature range of 36° to 46°F. Therefore, we have provided you with the ability to easily change the set point to meet your specific needs. The changes can be made on the temperature controller located on the bottom left corner of the unit front.

1. Press SET. SP1 will display (Fig. 7A).
2. Press SET. Current set point will display (Fig. 7B).
3. Press up or down on ADJUST to change the set point to desired temperature (Fig. 7C).
4. Press SET (Fig. 7D). The characters on the display will disappear for a moment (Fig. 7E) and then display the current temperature (Fig. 7F). The new set point is now accepted.

Note: See Fig. 8 for examples of temperature ranges by set point.

Fig. 8 – Examples of temperature ranges by set point

Set point temperature	Cut-in	Cut-out	Normal display range
38°	38°	34°	32° - 38°
39°	39°	35°	33° - 39°
40°	40°	36°	34° - 40°
41°	41°	37°	35° - 41°
42°	42°	38°	36° - 42°
43°	43°	39°	37° - 43°
44°	44°	40°	38° - 44°
45°	45°	41°	39° - 45°
46°	46°	42°	40° - 46°

Fig. 7

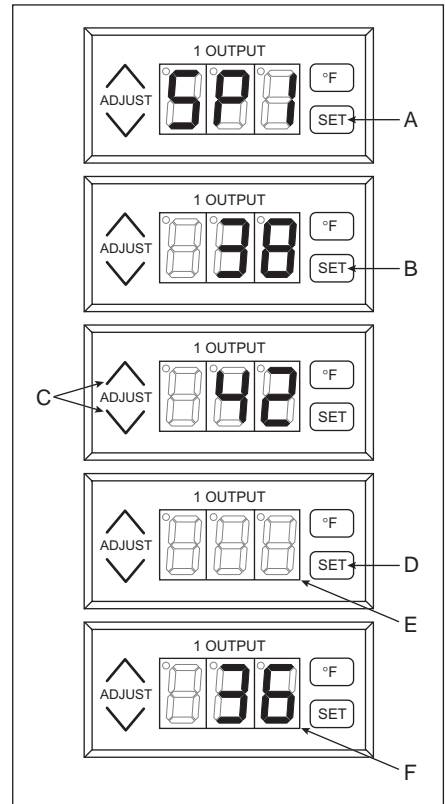

All set points have a built-in 3° differential. For example, the 3° differential means that with a 38°F set point, the compressor will turn on at 38°F and run through 37°, 36°, and 35°F (-3°) before turning off when it reaches 34°F. Because there is still refrigerant in the system, there can be an additional 1° - 1.5° of "drift" down in temperature after the compressor shuts off. The temperature may momentarily display as low as 32°F (32.9°F and below rounds down to 32°F) before beginning to rise again.

Operation

How the refrigerator works

The temperature control board and probe indicate when the refrigeration system is required to turn on and when it is required to shut off. The probe signals the controller to turn the refrigeration system on when the interior cabinet temperature rises to the controller set point. The normally open contacts of the controller close, energizing the coil of the control relay. Then the normally open contacts of the relay close, energizing the evaporator and condenser fan motors and the compressor. The compressor uses a current style starting relay and a starting capacitor to start the compressor motor. The refrigeration system then removes heat from the cabinet interior and rejects it to the surrounding room air. When the cabinet interior temperature falls by 3°F (controller will indicate 4°F, see controller adjustment instructions) the probe signals the controller to turn the refrigeration system off. The controller contacts reopen, de-energizing the control relay coil. The relay contacts reopen, which de-energizes the evaporator and condenser fan motors, and the compressor. Any accumulated frost on the evaporator coils melts during the off cycle. The condensate drains to the plastic drain pan mounted above the condensing unit where it is evaporated by the heat from the condensing unit.

Temperature control

The temperature control system is preset by the factory to maintain a cabinet temperature of 35°F - 38°F. If desired the cut in temperature of the controller can be raised to as high as 50°F by following the instructions for changing the temperature set point. The 3°F cut out differential will be maintained regardless of the controller set point.

Defrosting

REF Series undercounter refrigerators do not require manual defrosting. The unit cooler defrosts automatically when the condensing unit is in the OFF cycle.

Cleaning

Interior – Using a sponge or soft cloth, clean unit with a non-abrasive, non-chlorinated, all-purpose detergent.

Exterior – Wipe exterior with a soft cloth in the direction of grain as needed. Stainless steel polish may be used to enhance the finish of the unit.

Annual cleaning

Removal of dust and other particulates from air intake areas and the condenser is important to the proper operation of your Follett equipment. Some environments with large amounts of dust may require more frequent cleaning.

1. Disconnect power to unit by turning switch on the lower front panel to the OFF position, switching circuit breaker to OFF position, and removing power cord from receptacle.
2. Remove lower rear and lower front panels (Fig. 4A).
Note: Front louvered panel may be removed for more frequent cleaning of the condenser as needed
3. Remove drain pan (Fig. 4B).
4. Clean drain pan with a non-abrasive, non-chlorinated all-purpose detergent.
5. Reinstall drain pan.
6. Use a vacuum cleaner with brush attachment to clean condenser through lower front panel and compressor motor and related parts through lower rear panel.
7. Reinstall lower rear and lower front panels.

Fig. 4

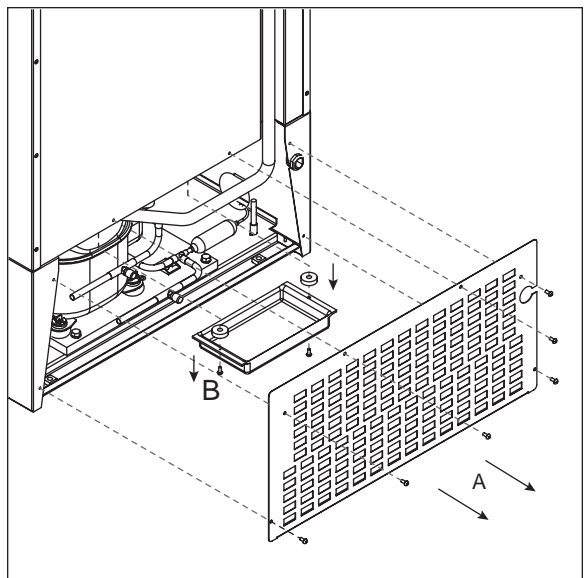

Service

Latch adjustment

To adjust for proper latch engagement

1. Loosen striker plate mounting screws (Fig. 5A).
2. Move striker plate up or down as required and tighten screws.
3. Test operation of latch.

To adjust for proper gasket seal

1. Loosen striker depth adjustment screw (Fig. 5B).
2. Adjust stop in or out and tighten screws.
3. Test operation of latch.

Gasket replacement

1. Remove existing gasket from mounting track in rear panel of door. Verify mounting track is free of any remaining gasket material.
2. Align new gasket with mounting track and press firmly in place.
3. Open and close door, checking for proper gasket seal without pinching against refrigerator. Adjust latch and or striker as necessary for proper door closure.

Slide-out compressor tray

A few of the most important benefits of Follett equipment are unsurpassed accessibility and ease of service. REF Series refrigerators continue this commitment with the ability to partially slide the condensing unit out of the base of the refrigerator to access service components without cutting refrigeration lines.

1. Remove the rear panel (Fig. 6A)
2. Remove the two screws and spacers securing the condensate pan, and set the pan aside (Fig. 6B).
3. Remove the two bolts securing the condensing unit to the refrigerator base (Fig 6C).
4. Gently slide the condensing unit out (Fig 6D).

Note: Do not put undue strain on the refrigerant lines

Wiring diagram

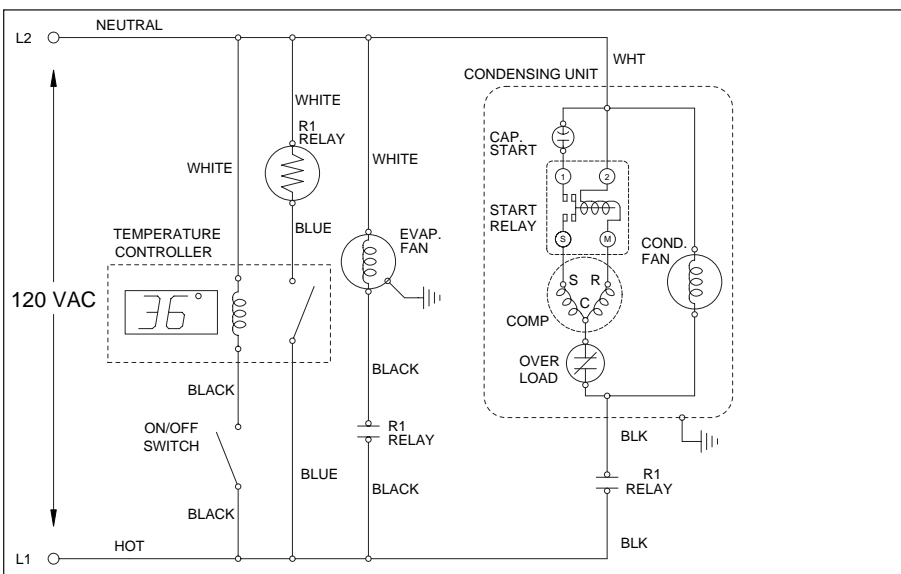

Fig. 5

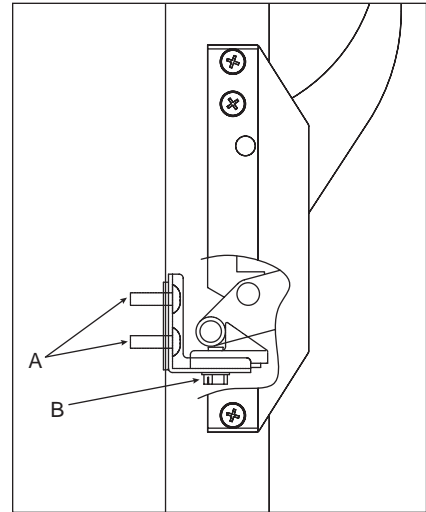
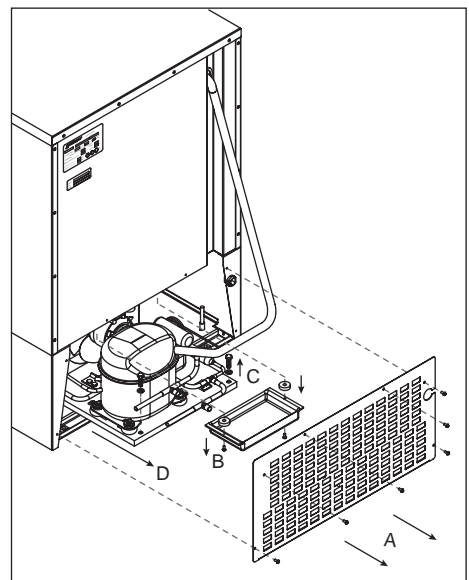

Fig. 6



Refrigeration system

The REF Series refrigeration system is designed to give many years of trouble-free service. Except for the cleaning of the air-cooled condenser and related parts, the refrigeration system requires no service or maintenance. The system uses a capillary tube and is critically charged. Access fittings are provided for ease of service. However, the connection of refrigeration service hoses to the fittings will almost invariably result in a significant change in the system charge. This change can adversely affect the performance of your refrigerator. Therefore, Follett recommends that if hoses are ever connected to the refrigeration system for service, the refrigerant should be recovered, the system evacuated, and recharged by weighing in the correct refrigerant charge.

Note: Do not charge the system by pressures.

Checking refrigeration system pressures

Remove the rear access panel (Fig. 4). Turn the power switch to the on position. Following the instructions on page 6 verify that the temperature controller is set to the original factory cut-in setting of 38°F. Allow the refrigerator to operate and stabilize at least 30 minutes verifying the cut-out temperature is being reached. Connect refrigerant hoses to access fittings and measure air temperature at condensor intake grille. Verify correct pressures with the temperature chart below.

Condensor inlet air temperature	70	80	90	100
Discharge pressure	198	230	270	311
Suction pressure	25	31	38	46

Troubleshoot refrigeration system as needed.

Note: Do not attempt to obtain correct refrigeration pressures by adjusting the system charge.

Refrigeration system diagram

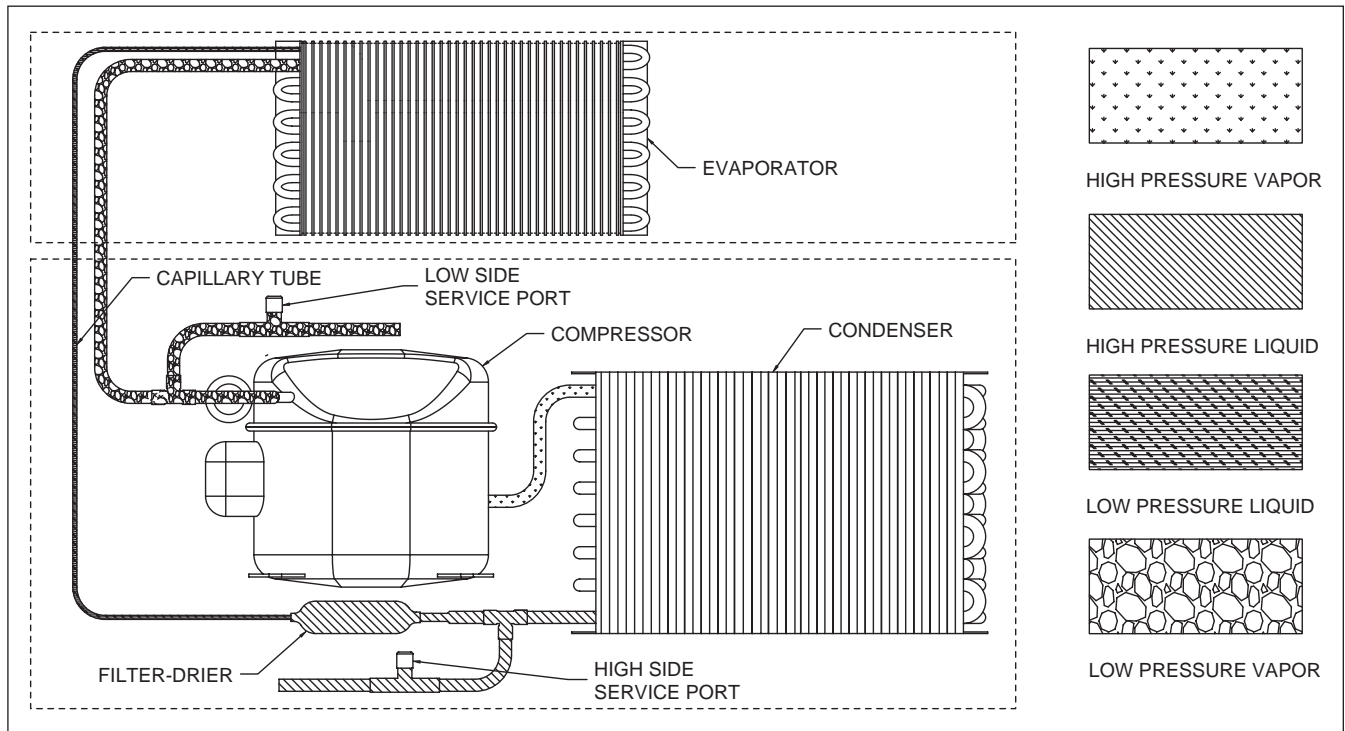

Refrigerator troubleshooting guide

Before calling for service

1. Check that unit is plugged in.
2. Test outlet with another appliance to verify power.

Symptom	Possible cause	Solution
Refrigerator does not operate (no components run)	<ol style="list-style-type: none"> 1. Power switch faulty or in OFF position; loose connection. 2. Temp controller not energizing control relay. 3. Defective control relay. 4. Refrigerator not plugged in. 5. No power to cord. 6. Probe not sensing cut in temperature. 	<ol style="list-style-type: none"> 1. Turn power switch to ON position; check switch and connections. 2. Check controller contact terminals for power. Replace controller if needed. 3. Replace relay. 4. Connect plug. 5. Restore power. 6. Replace controller and/or probe.
Compressor and condenser fan do not run.	<ol style="list-style-type: none"> 1. Condensing unit power cord not plugged in to socket. 2. Control relay contacts not closing. 	<ol style="list-style-type: none"> 1. Reconnect power cord. 2. Replace relay.
Compressor does not run.	<ol style="list-style-type: none"> 1. Thermal overload open or defective. 2. Capacitor and/or relay defective. 3. Compressor defective. 	<ol style="list-style-type: none"> 1. Allow to cool or replace. 2. Replace as required. 3. Replace compressor.
Evaporator fan motor does not run.	<ol style="list-style-type: none"> 1. Evaporator power cord not plugged in to socket. 2. Control relay contacts not closing. 3. Defective fan motor. 	<ol style="list-style-type: none"> 1. Reconnect power cord. 2. Replace relay. 3. Replace fan motor.
Refrigerator does not shut off.	<ol style="list-style-type: none"> 1. Controller not sensing cut off temperature. 2. Controller keeping control relay energized. 3. Control relay stuck closed. 	<ol style="list-style-type: none"> 1. Replace controller and/or probe. 2. Replace controller. 3. Replace control relay.
Refrigerator does not maintain temperature (all components run).	<ol style="list-style-type: none"> 1. Condenser or evaporator coil needs cleaning. 2. Insufficient ventilation. 3. Faulty door gasket. 4. Excessively high ambient. 5. Refrigerant leak. 6. Incorrect refrigerant charge. 7. Plugged capillary tube. 8. Inefficient compressor. 	<ol style="list-style-type: none"> 1. Clean coils as needed. 2. Check ventilation clearance requirements. Adjust as needed. 3. Replace door gasket. 4. Maximum recommended ambient is 100 degrees F. 5. Locate and repair leak. 6. Recover, evacuate and weigh in correct charge. 7. Replace capillary tube. 8. Consult technical service.

If problems persist after following this basic troubleshooting guide, call Follett's technical service group at (800) 523-9361, (888) 2-FOLLETT or (610) 252-7301.

Accessories

Temperature alarm

Before installing alarm

1. Remove supplied 9-volt back-up battery from packing box.
2. Remove 2 screws from module face and remove faceplate.
3. Locate DIP switches on the back of the faceplate (Fig. 1).
4. Verify that the DIP switch settings meet the needs of your facility (Fig. 2).
5. Install back-up battery on battery connector.
6. Reinstall faceplate.

Fig. 1

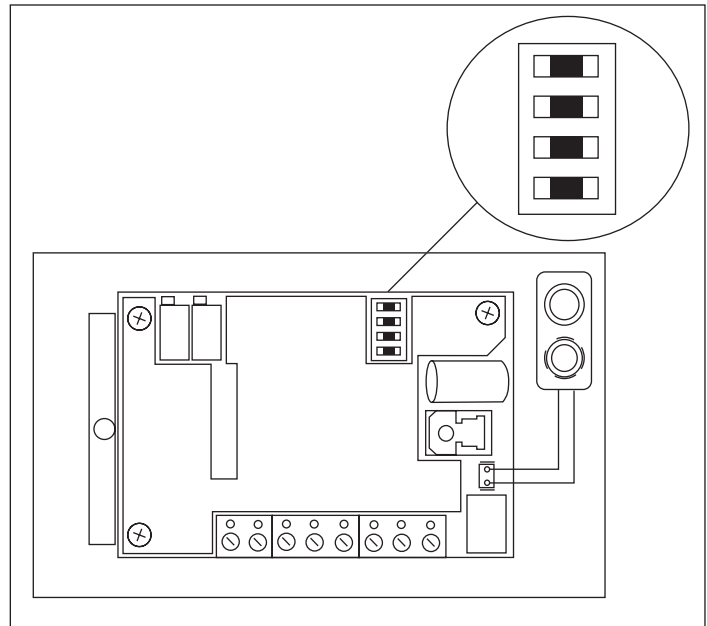

Fig. 2

Dip Switch	ON	OFF (factory default setting)
1	45 minute alarm delay	No alarm delay
2	Manual reset of alarm (user must press RESET button to stop audible alarm even if temperature has returned to set range)	Auto reset (alarm stops automatically as soon as temperature returns to set range)
3 & 4	No audible alarm	Audible alarm on
3	Enables 45 min alarm "snooze" when reset button is pressed (with 4 off)	Enables 5 min alarm "snooze" when reset button is pressed (with 4 on)

Installing alarm

1. Mount alarm on wall within 4 feet of refrigerator with screws (supplied by others) through back of housing.
2. Plug power cord into 110 outlet.
3. Push center tab of bottle bracket into top of rear left support bracket (Fig. 3).
4. Fill bottle with glycerin or other liquid to increase accuracy of readings by simulating the internal temperature of medications.
5. Insert bottle into bottle bracket.
6. Route probe through hole in refrigerator back and push probe down through gasketed bottle top.

Note: Do not modify length of probe wire. Probe will not measure temperature correctly if wire length is changed.

Note: Alarm probe must be placed in bottle for proper system operation

Fig. 3

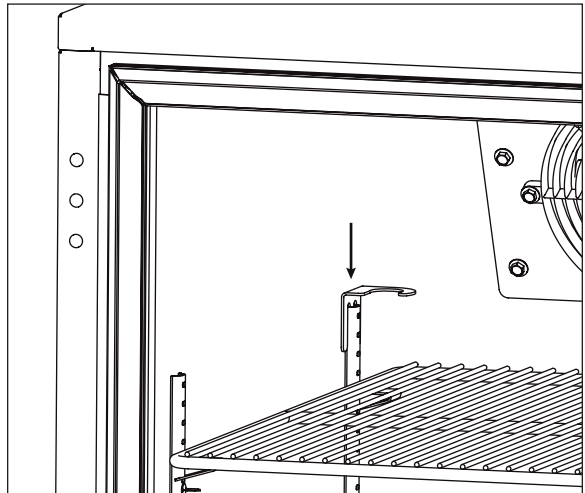

- The controller contains a SPDT 1 amp 24V AC resistive output for wiring alarm to central monitoring or central alarm system (Fig. 4).

Fig. 4

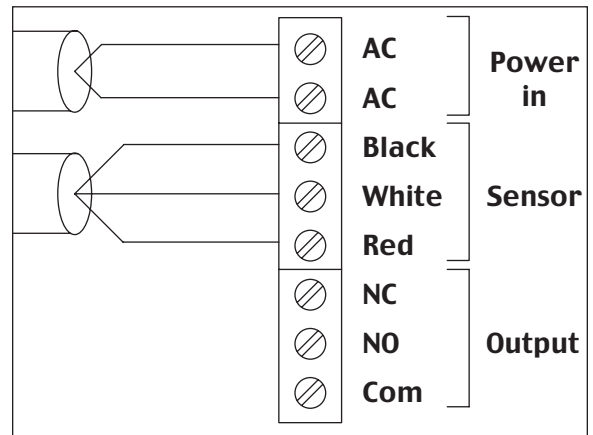

Setting alarm temperatures

- After the installation is complete allow 30 minutes for the system to stabilize to ambient temperature.
- Calibrate temperature alarm to refrigerator display
 - Press SET button to display "CAL" (Fig. 5A).
 - Press top or bottom of ADJUST arrow to show same temperature as displayed by refrigerator (Fig. 5B).
- Set high alarm limit
 - Press SET button to display "HSP" (Fig. 5A).
 - Press SET again to display HSP value (Fig. 5A).
 - Press top or bottom of ADJUST arrow until desired HSP value is displayed (Fig. 5B).
- Set low alarm limit
 - Press SET button to display "LSP" (Fig. 5A).
 - Press SET again to display LSP value (Fig. 5A).
 - Press top or bottom of ADJUST arrow until desired LSP value is displayed (Fig. 5B).

Fig. 5

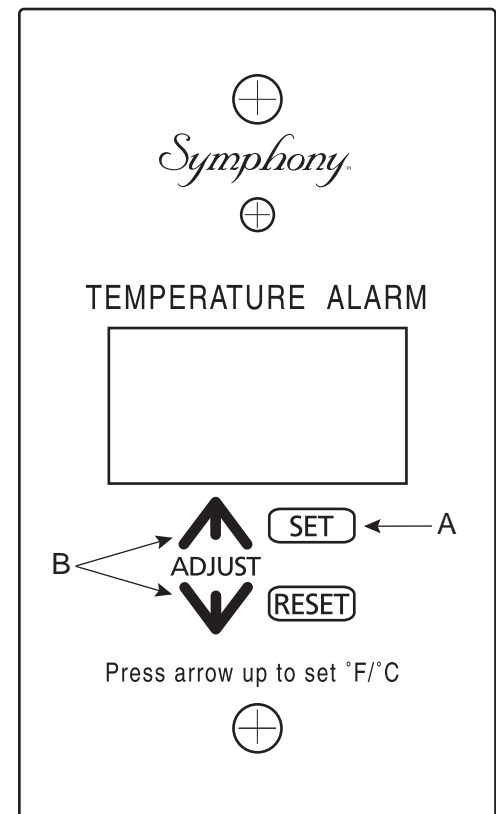

Alarm operation facts

Battery will transmit audible alarm during power failure. Press RESET to read display.

To see the highest or lowest temperature since last reset, press the button until "HI" or "LOW" appears. To clear log value, press RESET.

Because the temperature alarm display simulates the true temperature of stored medications rather than the air temperature inside the refrigerator, we suggest that staff refer to the alarm display to log temperatures for JCAHO compliance.

Pyxis® system interface

The Pyxis-compatible door bracket interfaces with Pyxis' standard lock box. The bracket must be installed by Pyxis authorized installing technicians. Contact Pyxis directly at 800-367-9947 for questions relating to Pyxis system operation.

Replacement parts

Evaporator - Reference #5

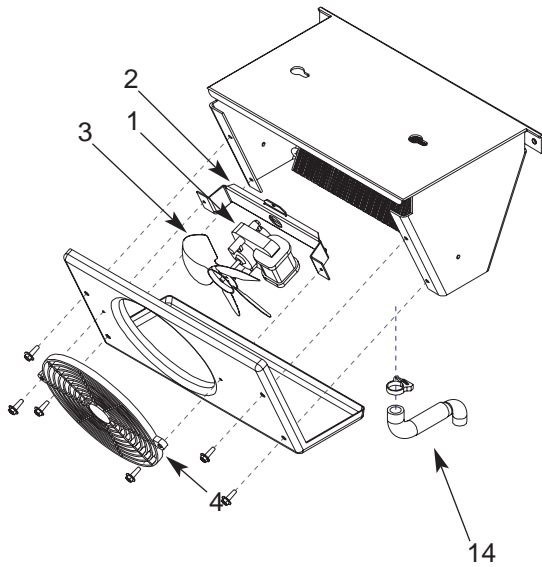

Condensing unit - Reference #11

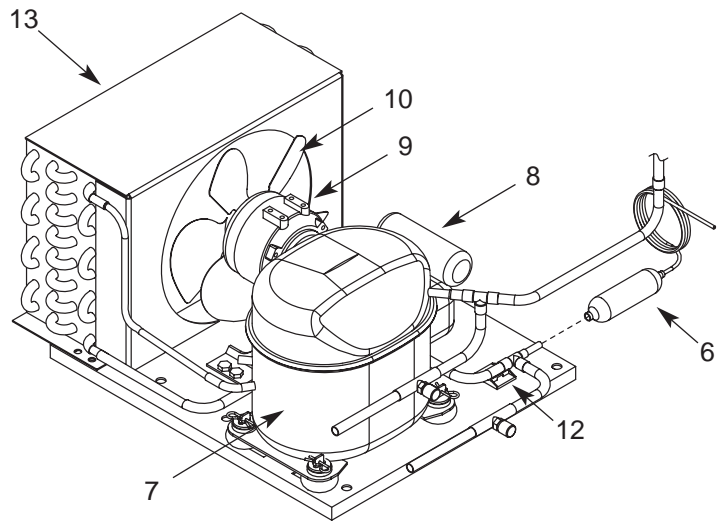

Refrigeration

Reference #	Description	Part #
1	Fan motor, evaporator	00104919
2	Bracket, fan motor	00104927
3	Fan blade	00104935
4	Fan guard	00104943
5	Evaporator (includes parts above)	00104885
6	Filter drier & capillary tube	00103267
7	Compressor	00104950
8	Starting capacitor	00104968
Not shown	Starting relay	00104976
Not shown	Overload protector	00104984
9	Condenser fan motor	00104992
10	Condenser fan blade	00105007
11	Condensing unit	00105106
12	Wiring strain relief	00105577
13	Condenser	00105619
Not shown	Cap, starting capacitor	00105627
14	Drain tube, evaporator (includes clamp)	00121681

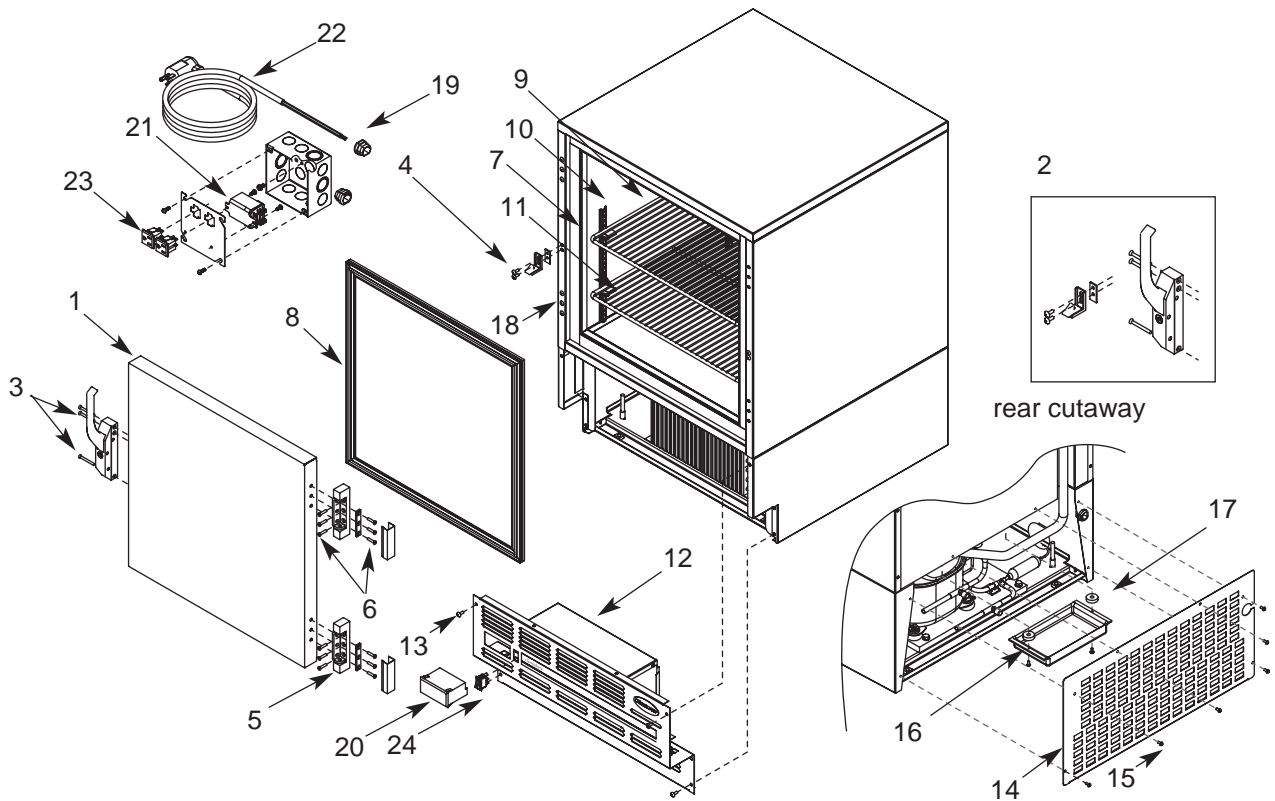

Hardware

Reference #	Description	Part #
1	Door, REF5 (includes gasket – 21 5/8" x 21 5/8")	00105015
Not shown	Door, REF4-ADA (includes gasket – 18 5/8" x 21 5/8")	00113910
2	Latch & striker (includes screws)	00105023
3	Latch screws (each – 3 per latch)	00103507
4	Striker screws (each – 2 per striker)	502287
5	Hinge (each – 2 required, includes screws)	00105031
6	Hinge screws (each – 6 per hinge)	00105080
7	Strip sealer (set of 4)	00105049
8	Gasket, REF5 (21 5/8" x 21 5/8" Door)	00103291
Not shown	Gasket, REF4-ADA (18 5/8" x 21 5/8" Door)	00108092
9	Shelves (each)	00103283
10	Pilaster (each)	00105346
Not shown	Thumb screws (set of 8)	00105353
11	Shelf support (snap-in, each)	00105361
12	Lower front panel (includes 00114371 and screws)	00105056
13	Front panel screws (each – 6 per panel)	00105379
14	Rear panel (includes screws)	00105064
15	Rear panel screws (each – 6 per panel)	00105387
16	Condensate tray (includes screws & spacers)	00103275
Not shown	Key	00105072
17	Spacer, condensate pan	00105098
Not shown	Seal, bushing, rear panel	00114512

Electrical components

18	Finishing plug	00105536
Not shown	Leveling leg	00103432
19	Strain relief, power cord	00105403
20	Temperature controller	00103358
21	Control relay	501369
22	Power cord	00103903
23	Socket (each – 2 required)	00103887
24	Power switch, flush mount (before svc# B28296)	502209
	Power switch, recessed mount (after svc# B28296)	00114371
Not shown	Strain relief, wiring, front panel	00105577

Temperature alarm accessory

Reference #	Description	Part #
Not shown	Bottle kit (includes bottle, bracket and gasket)	00113779
Not shown	Controller kit (includes battery, probe and power supply)	00108175
Not shown	Gasket, bottle	00112029
Not shown	Bracket, bottle	00112011
Not shown	Bottle	00112037
Not shown	Battery	00112177
Not shown	Screws, (includes two for securing cover)	00115063
Not shown	Label, controller cover	00115071
Not shown	Temperature probe	00115097

Pyxis accessory

Not shown	Pyxis door bracket	00114702
-----------	--------------------	----------

