



Project _____
 Item _____
 Quantity _____
 CSI Section 11400 _____
 Approval _____
 Date _____

Shortening Disposal Units

Shortening Disposal Units

Models

PSDU50

PSDU90



Standard Features

- 9.6" (244 mm) drain height (with cover open) allows unit to fit under most frypots to permit direct draining of oil into unit
- Heavy-duty manual pump can empty 50 lbs. (25 liters) of oil in less than 60 seconds
- Large 7" (178 mm) wheels provide easy transporting of oil, even across parking lots; and no lifting is necessary
- 90 days parts and labor warranty; pump warranted one year, parts only

Options & Accessories

- 24" hose
- 48" hose

Specifications

Specifically designed for the removal of waste oil from the kitchen

Frymaster provides the answer for the transportation of waste oil from the kitchen to the disposal container, with shortening disposal units, available in 50- and 90-lb. (25- and 45-liter) capacities.

The low center of gravity provides stability when transporting or operating the unit. The heavy-duty manual pump is located at a convenient height; so there is no stooping or bending required. Also, there is no lifting required to operate the unit.

The Frymaster Shortening Disposal Units fit FootPrint PRO® filtration batteries to allow easy disposal of used shortening.

8700 Line Avenue
 Shreveport, LA 71106-6800
 USA

Tel: 318-865-1711
 Tel: 1-800-221-4583
 Fax: 318-868-5987
 E-mail: info@frymaster.com

www.frymaster.com
 Bulletin No. 818-0109 3/08



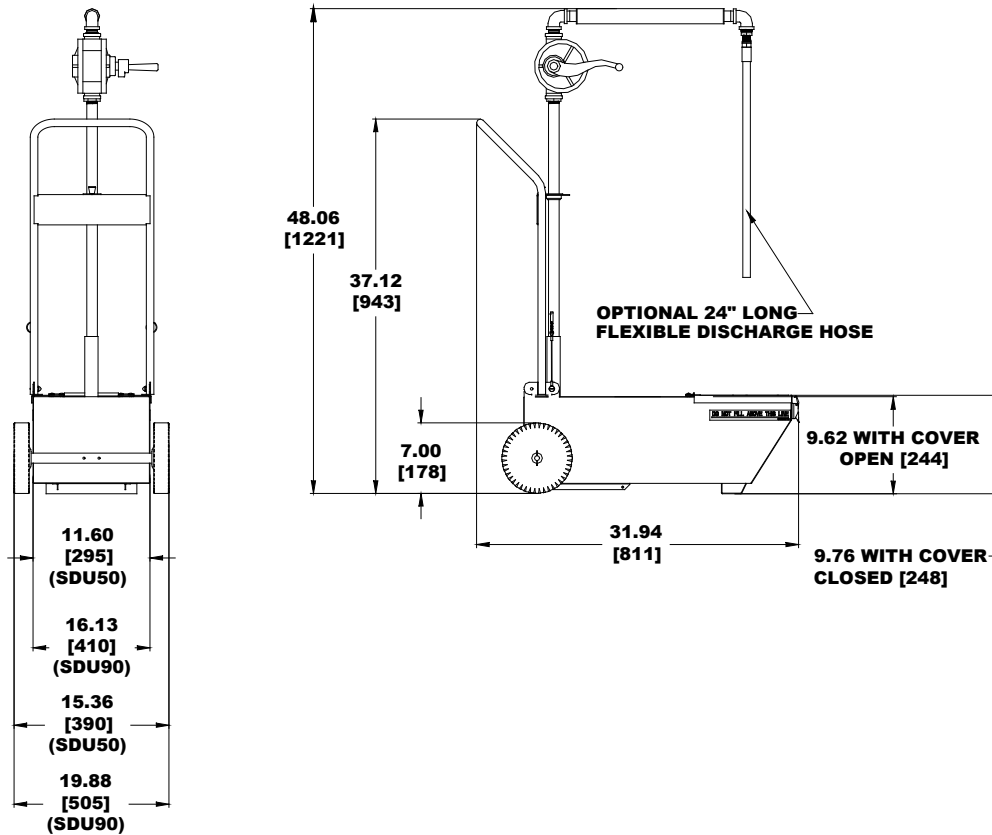

DIMENSIONS

MODEL NO.	SHORTENING CAPACITY	ASSEMBLED SIZE (cm)			DRAIN HEIGHT	NET WEIGHT	SHIPPING INFORMATION					
		HEIGHT	WIDTH	LENGTH			WEIGHT	CLASS	CU. FT.	DIMENSIONS		
PSDU50	50 lbs. (25 liters)	48.06" (1221)	15.36" (390) Overall 11.60" (295) Tank Only	31.94" (811)	9.62" (244) w/door open	45 lbs. (20 kg)	62 lbs. (28 kg)	85	7	H 20" (508)	W 21" (533)	L 30" (762)
PSDU90	90 lbs (45 liters)	48.06" (1221)	19.88 (505) Overall 16.13 (410) Tank Only	31.94" (811)	9.62" (244) w/door open	49 lbs. (22 kg)	67 lbs. (30 kg)	85	10	20" (508)	23" (584)	39" (991)

ORDERING DATA

Please specify:

SDU50 -- 50-lb. (25-liter) capacity

SDU90 -- 90-lb. (45-liter) capacity

Model # _____
CSI Section 11400