

NAVY SURFACE SHIP ELECTRIC FRYERS

CHAPTER 8: PARTS LIST

8.1 Accessories

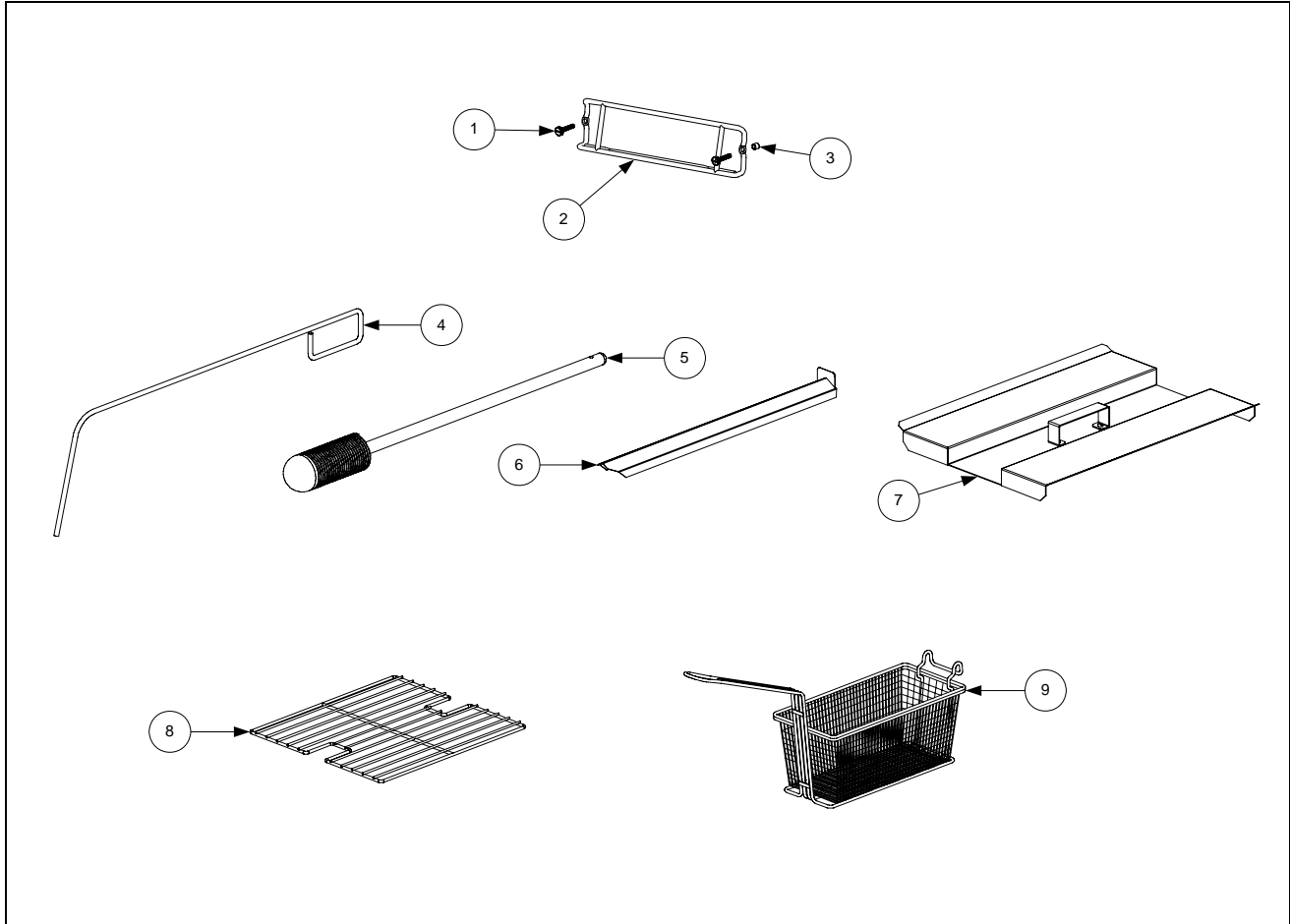

ITEM	STANDARD PART #	**EURO-LOOK PART #	COMPONENT
1	809-0171		Thumbscrew, 1/4 -20 X 1 3/8-inch
2	810-2793		Hanger, Wireform Basket
3	809-0921		Spacer, Basket Hanger
4	803-0197		Cleanout Rod, 27-inch
5	803-0209		Brush, Frypot
6	823-1885		Connecting Strip, Frypot
7	806-4041		Cover, Full-Vat Frypot
8	803-0132		Rack, Full-Vat Basket Support
9	803-0271		Basket, Twin
*	812-1226SP		Drain Nipple 1 1/4-inch Painted
*	803-0002		Powder, Filter (80 1-Cup Applications)
*	803-0170		Paper, Filter (100-Sheet Pack)

* Not illustrated.

■ Use standard part.

** Euro-Look fryers have rounded topcaps and round drains whereas, standard fryers have square drains and topcaps.

8.2 Cabinetry

8.2.1 Backs, Control Panels, Doors, Handles, Sides, Tilt Housings & Top Caps

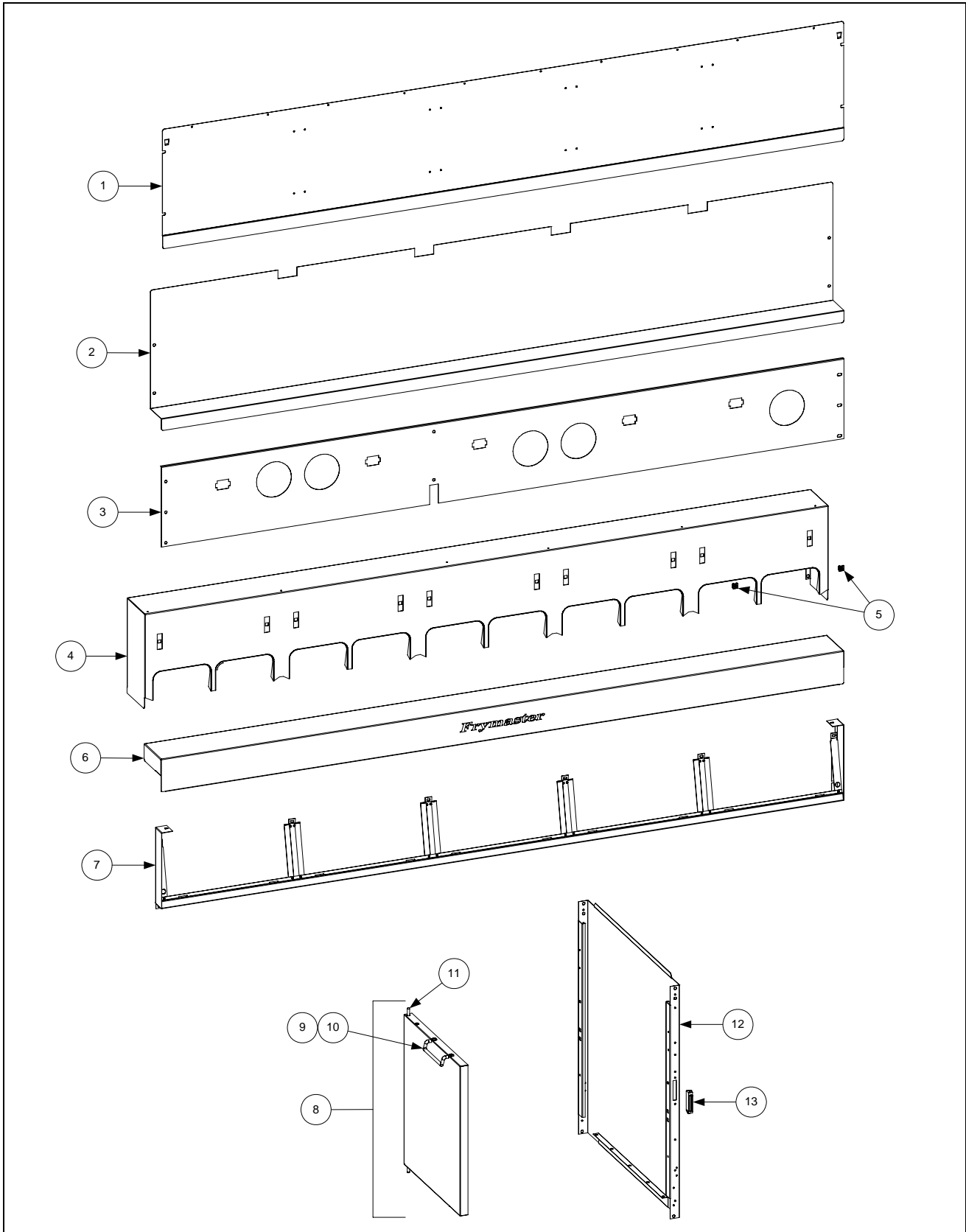

8.2.1 Backs, Control Panels, Doors, Handles, Sides, Tilt Housings & Top Caps (cont.)

ITEM	STANDARD PART #	EURO-LOOK PART #	COMPONENT
1	210-9367		Back Panel, Upper (Single)
	210-2299	200-6630	Two Station Fryer
	210-2380	200-6785	Three Station Fryer
	210-3490	200-6786	Four Station Fryer
	210-3670	200-6787	Five Station Fryer (Panel for five station fryer shown)
2	210-9336		Back Panel, Center (Single)
	210-2298	200-2298	Two Station Fryer
	210-2379	200-2379	Three Station Fryer
	210-3489	200-3489	Four Station Fryer
	210-3669	200-3669	Five Station Fryer (Panel for five station fryer shown)
3	210-9339		Back Panel, Lower (Single)
	210-4430	200-4426	Two Station Fryer
	210-4431	200-4427	Three Station Fryer
	210-4432	200-4428	Four Station Fryer
	210-4433	200-4429	Five Station Fryer (Panel for five station fryer shown)
4	824-1526		Tilt Housing (Single)
	824-1061	824-1303	Two Station
	824-1062	824-1335	Three Station
	824-1063	824-1336	Four Station
	824-1065	824-1337	Five Station (Housing for five station fryer shown)
5	826-1351	826-1351	Nut Retainer, 1/4-20 (Pkg. of 10 – receives basket hanger thumbscrew)
6	106-5205	106-5195	Top Cap (Single) (Top cap for five station fryer shown)
	106-5206	106-5196	Two Station
	106-5207	106-5197	Three Station
	106-3036SP	106-5198	Four Station
	106-4441	106-5199	Five Station (<i>Also requires ten 809-0078 10-32 Nutserts</i>)
7	106-4956		Frame, Control Panel (Frame for five station fryer shown)
	806-7172SP	106-4378	Two Station Fryer
	806-7173SP	106-4391	Three Station Fryer
	806-7174SP	106-4392	Four Station Fryer
	106-2171SP	106-4393	Five Station Fryer
8	806-6545SP	106-4397	Door, Left or Right (Left shown – move handle to opposite side for Right)
9	809-0266		Screw, #10 X 1/2-inch Phillips Truss Head
10	810-1422	210-6816	Handle, Wireform Door
11	806-4487SP		Pin Assembly, Door
*	826-1343		Spring, Door Pin (Pkg. of 10)
*	106-5008	106-4979	Door Assembly (Single)
12	210-4435		Side, Standard Cabinet Left or Right
*	211-8479		Side, Cabinet Single Left (<i>Use 212-8479 for Rt. Side</i>)
13	810-2346	810-1105	Magnet, Door
			Handle (Grab Rail) (<i>For handle end use 910-0915</i>)
*	823-0839	823-0839	One Station Fryer
*	823-2908	823-2908	Two Station Fryer
*	823-2901	823-4585	Three Station Fryer

* Not illustrated.

■ Use standard part.

8.2.2 Cabinet Bases, Braces, and Associated Parts

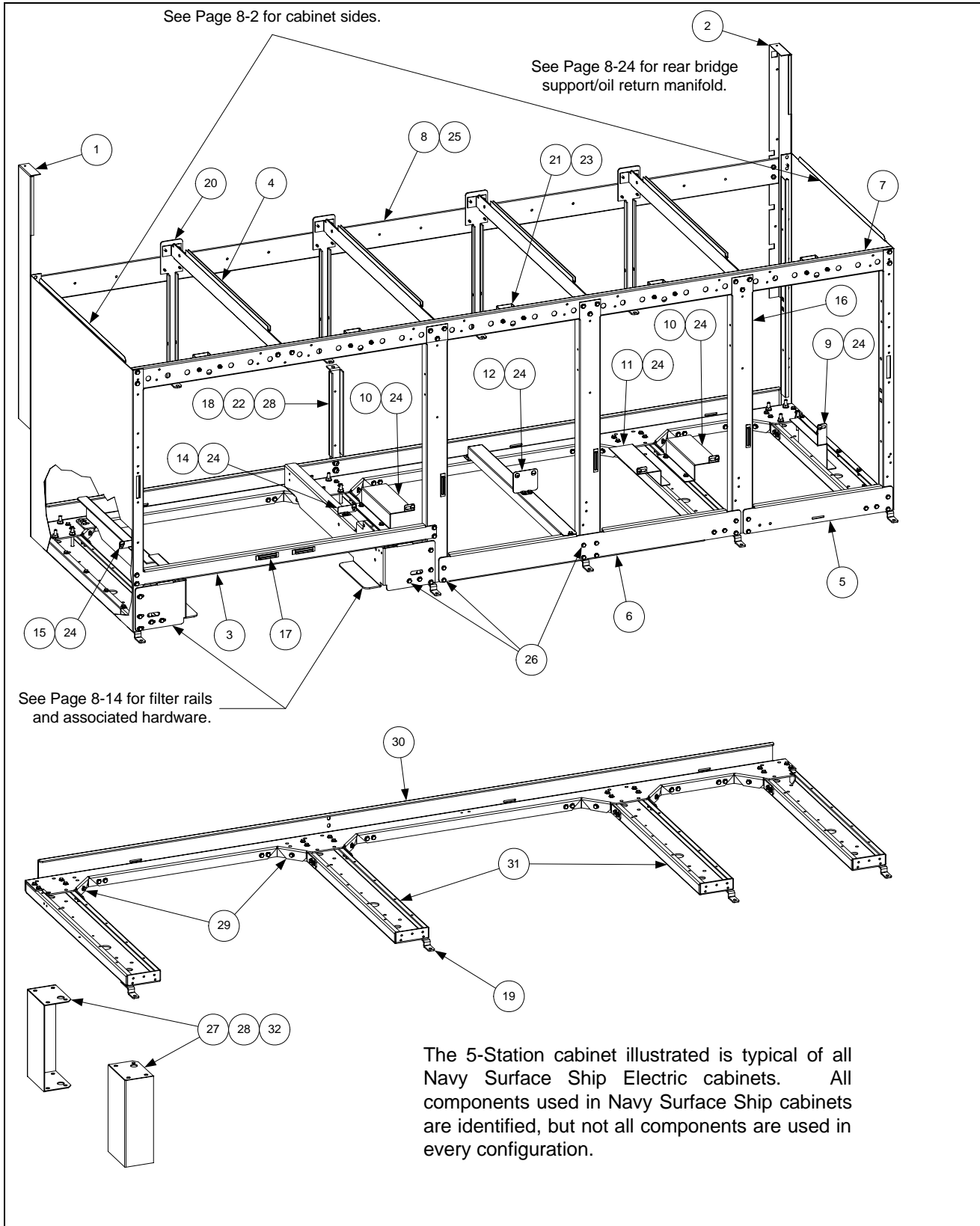

8.2.2 Cabinet Bases, Braces, and Associated Parts (cont.)

ITEM	STANDARD PART #	EURO-LOOK PART #	COMPONENT
1	106-1265		Upright Assembly, Left (<i>Use 106-3828 for singles</i>)
2	106-1266		Upright Assembly, Right (<i>Use 106-3829 for singles</i>)
3	200-1651		Support, Cross Cabinet
4	200-1659		Divider, Cabinet
5	200-2293		Brace, Single Station Lower
6	200-3774		Brace, Double Station Lower
7			Brace, Front Horizontal (<i>Use 200-7036 for singles</i>)
	200-2331		Two-Station Fryer
	200-2296		Three-Station Fryer
	200-2733		Four-Station Fryer
	200-3590		Five-Station Fryer
8			Brace, Rear Horizontal (<i>Use 200-5356 for singles</i>)
	200-2284		Two-Station Fryer
	200-2295		Three-Station Fryer
	200-2725		Four-Station Fryer
	200-3592		Five-Station Fryer
9	200-4422		Support, Contactor Box Right Station 3 or Station 5
10	201-4425		Support, Contactor Box Left Station 4 or Station 5
11	202-4425		Support, Contactor Box Right Station 3
12	200-4423		Support, Contactor Box Stations 3 and 4
13	200-4447		Support, Contactor Box Front to Rear
14	201-5369		Support, Contactor Box Station 2
15	202-5369		Support, Contactor Box Station 1
*	200-6498		Support, Contactor Box (Singles)
16	200-4424		Post, Door
17	810-2346		Magnet, Door
18	200-4786		Support, Oil Return Manifold
19	210-5595		Hinge, Door (<i>Use 210-6862 for singles</i>)
20	210-1490		Bracket, Rear Support
21	900-1224		Bracket, Frypot
22	826-1389		Bolt, 1/4-20 X 3/4-inch Hex Head (Pkg. of 10)
23	826-1371		Screw, #8 X 1/2-inch Drill Point Hex Head (Pkg. of 25)
24	826-1330		Screw, 10-32 X 3/8-inch Slotted (Pkg. of 25, used to attach contactor box)
25	826-1376		Nut, 10-32 Keps Hex (Pkg. of 10)
26	826-1374		Screw, #10 X 1/2-inch Hex Washer Head (Primary cabinet screw) Qty 25
27	809-0417		Nut, 1/4-20 Hex Flange (used with item #22)
28	809-0429		Bolt, 1/4-20 X 2-inch Hex Head
29	200-5417		Brace, Rear Channel Corner
30			Channel, Base Rear (<i>Use 106-4901 for singles base assembly</i>)
	200-5463		Two-Station Fryer
	200-5538		Three-Station Fryer
	200-5537		Four-Station Fryer
	200-5536		Five-Station Fryer
31	824-1131		Channel, Base Side
32	823-4386		Leg, Navy Shipboard (Mounts with Items 27 and 28)

Use Standard part.

8.3 Drain System Components

8.3.1 Drain Tube Sections and Associated Parts

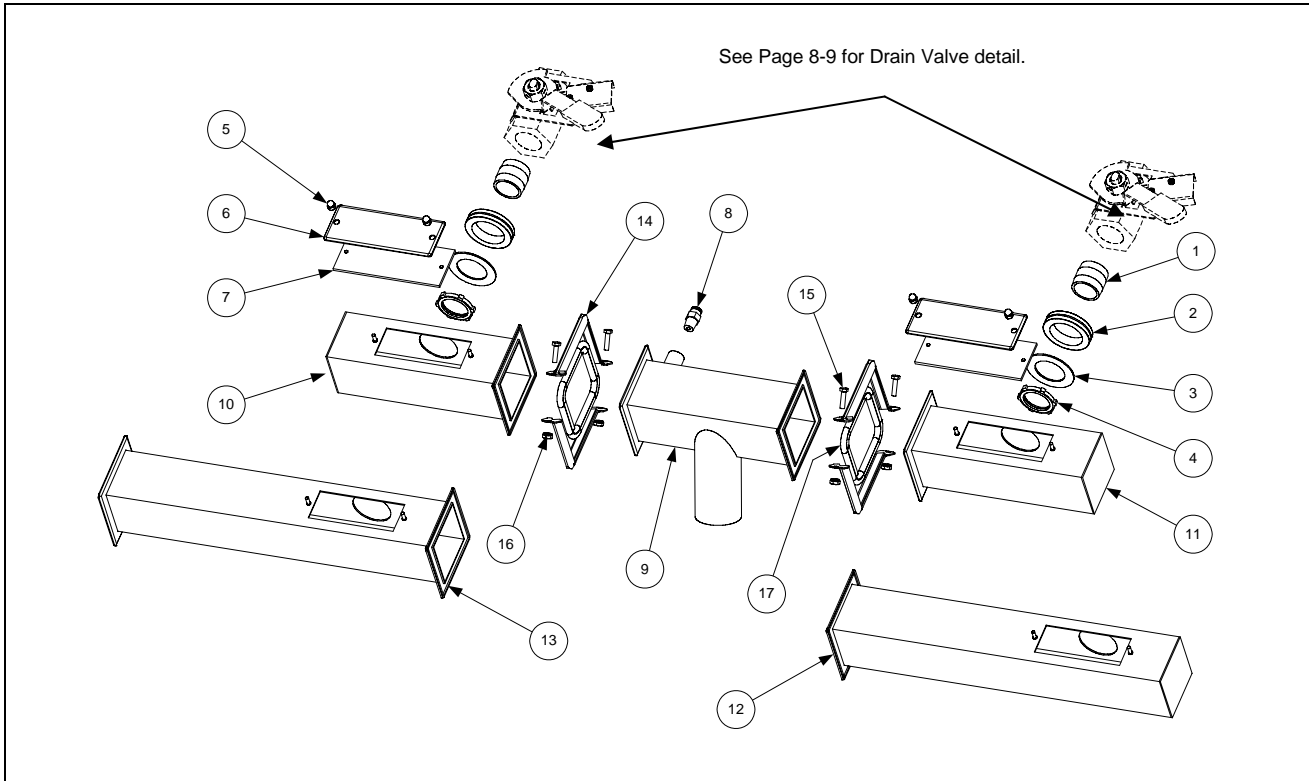

ITEM	STANDARD PART #**	COMPONENT
1	813-0284	Nipple, 3/4 X 1-inch NPT
2	816-0092	Grommet, 1-inch Drain
3	826-1345	Washer, 1-inch Drain (Pkg. of 25)
4	809-0347	Nut, 1-inch NPT Retainer
5	809-0893	Nut, 8-32 High Crown Acorn
6	826-1348	Cover, Drain Cleanout (Pkg. of 5)
7	816-0021	Gasket, Drain Cleanout
8	810-2492	Fitting, Quick-Connect Straight (receives Teflon vent tube)
9	823-3229	Drain Outlet
10	823-3380	Drain Tube, Left End
11	823-1549	Drain Tube, Right End Short
12	823-1508	Drain Tube, Right End Long
13	823-0717	Drain Tube, Open End Long
14	810-0396	Clamp, Square Drain
15	826-1375	Screw, 10-32 X 3/4-inch Hex Head (Pkg. of 5)
16	826-1376	Nut, 10-32 Keps Hex (Pkg. of 10)
17	816-0032	Gasket, Square Drain
*	826-0877	Kit, Square Drain Clamp (2 each of Items 14-16 and 1 of Item 17)
*	811-1071	Tube, Teflon Vent 1/4-inch OD

* Not illustrated.

** See page 8-8 for a Euro-Look parts list.

8.3.1.1 Euro-Look Drain Tube Section and Associated Parts (cont.)

ITEM	EURO-LOOK PART# **	COMPONENT
1		Drain Tube, Left/Right End Short
	823-4625	Full-Vat 3"
	823-4624	Dual-Vat 3"
2		Drain Tube, Left/Right Open Short
	823-4643	Full-Vat 3"
	823-4642	Dual-Vat 3"
3		Drain Tube, Right End Long
	823-4639	Full-Vat 3"
	823-4638	Dual-Vat 3"
4		Drain Tube, Left/Right Open Long
	823-4641	Full-Vat 3"
	823-4640	Dual-Vat 3"
5	823-4892	Drain Outlet Center Dump
6	816-0625	Sleeve 3"
7	809-0969	Clamp, 3" T-Bolt
8	810-2492	Fitting, Quick-Connect Straight (receives Teflon vent tube)
*	KIT6033	Kit, Round Drain Clamp (2 or Item 7 and 1 of Item 6)
*	811-1071	Tube, Teflon Vent 1/4-inch OD

* Not illustrated.

** See page 8-6 for a standard parts list.

8.3.2 Drain Valve Assembly and Component Parts

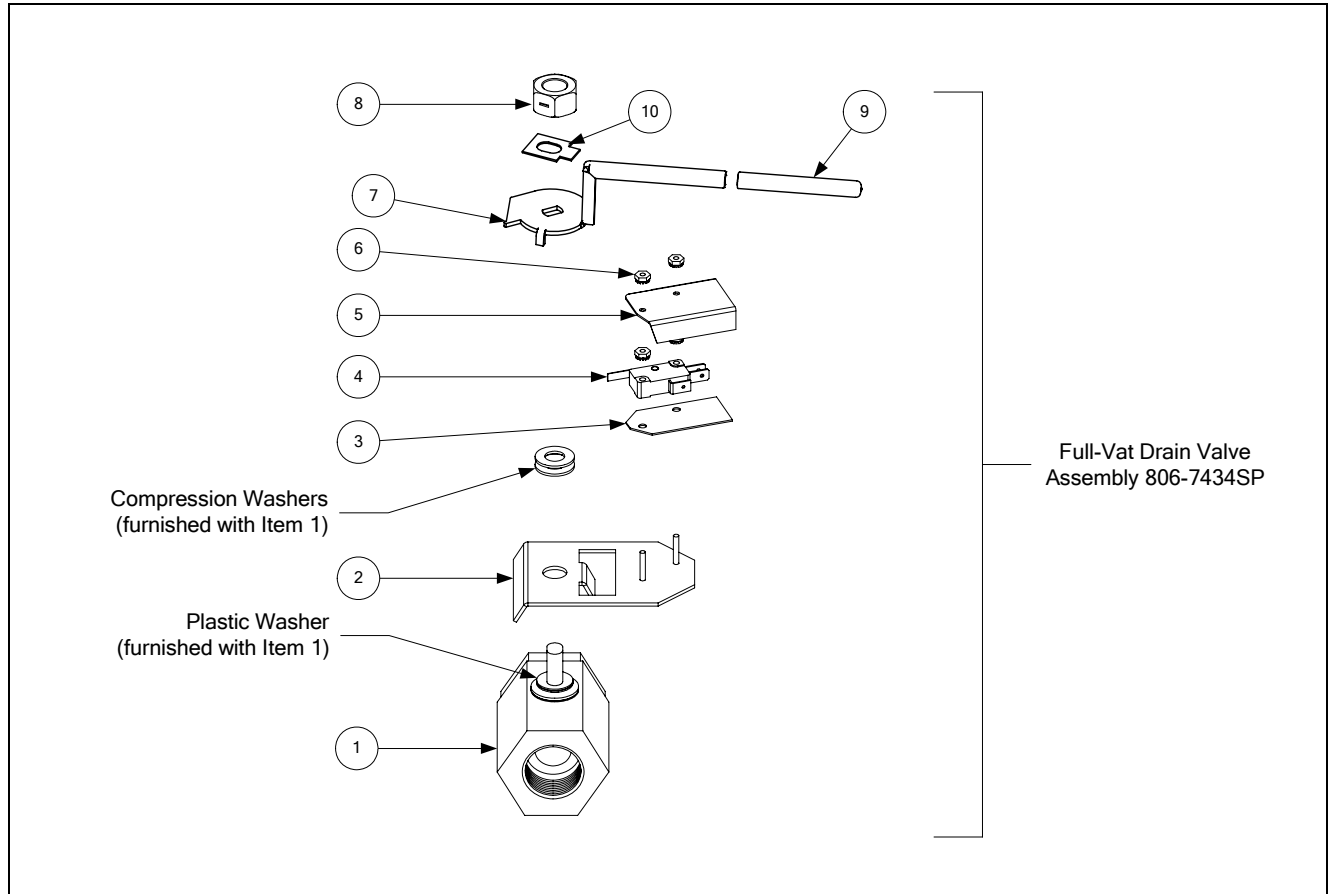

ITEM	STANDARD PART #**	COMPONENT
1	810-1020	Valve, 1-inch Full-Vat Drain
2	806-8137	Bracket Assembly, Full-Vat Drain Safety Switch
3	816-0220	Insulation, Drain Safety Switch
4	807-2103	Microswitch, CE Straight Lever
5	901-2348	Cover, Dual Vat Drain Safety Switch
6	826-1366	Nut, 4-40 Keps Hex (Pkg. of 25)
7	824-1602	Handle, Full-Vat Drain Valve
8	809-0540	Nut, ½-13 2-Way Hex Lock
9	816-0639	Sleeve, Red Handle
10	900-2936	Retainer, Nut Drain Valve FV
*	806-6993SP	Valve, 1 ¼-inch Drain Assembly (Includes handle and sleeve)
*	823-1168	Valve, 1 ¼-inch Drain Assembly with bracket (used on non-filter fryers)
*	WIR0572	Wire Bundle, Drain Safety Switch

* Not illustrated.

* See page 8-11 for a *Euro-Look* parts list.

**8.3.2.1 Euro-Look Drain Valves and Associated Parts
(Units with Built-In Filtration)**

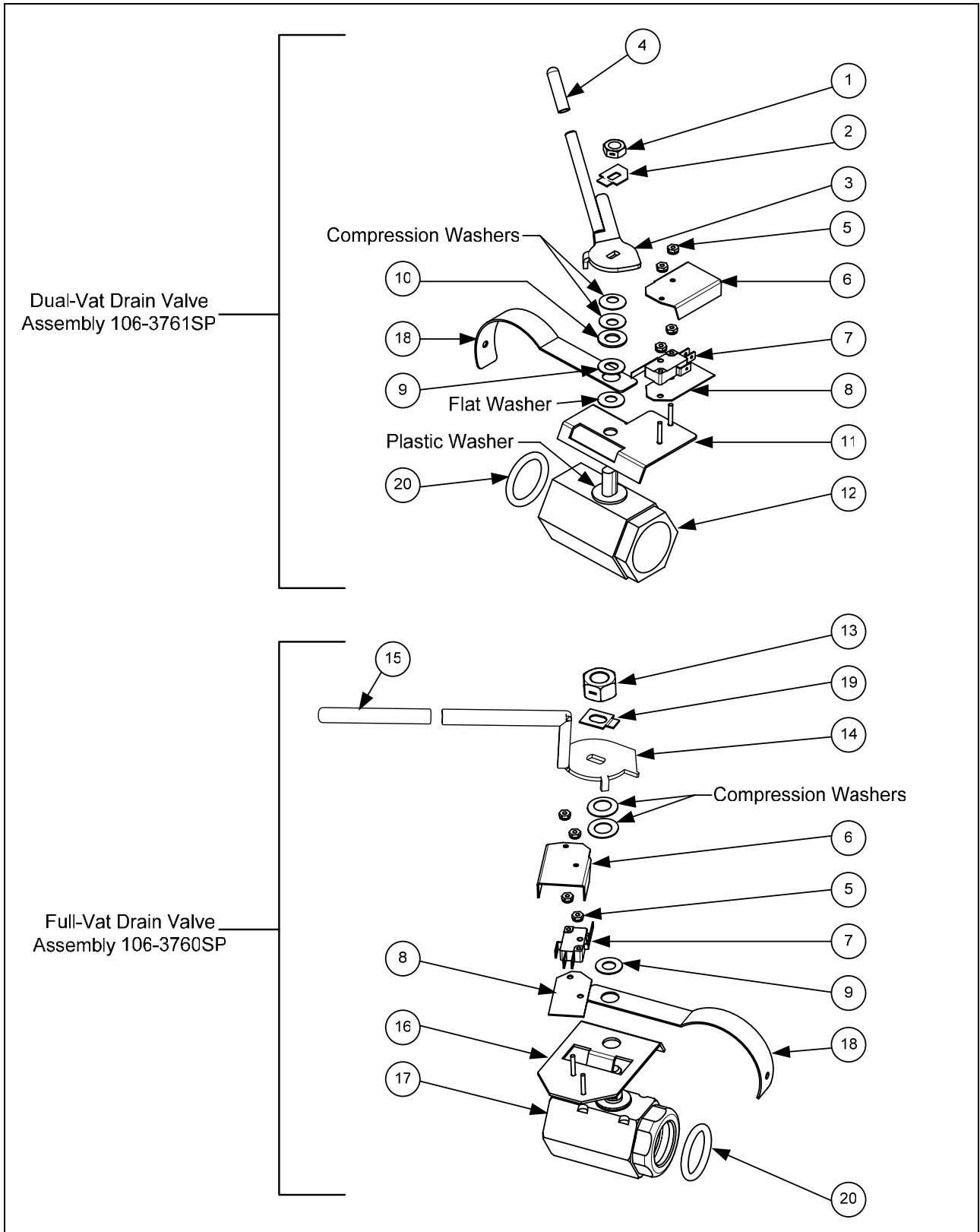

**8.3.2.1 Euro-Look Drain Valves and Associated Parts
(Units with Built-In Filtration) cont.**

ITEM	EURO-LOOK PART#**	COMPONENT
1	809-0539	Nut, 3/8-16 2-Way Hex Lock
2	900-2934	Retainer, Dual-Vat Drain Valve Nut
3	823-5369	Handle, Dual-Vat Drain Valve
4	810-0677	Grip, Drain Handle
5	826-1366	Nut, 4-40 Keps Hex (Pkg. of 25)
6	901-2348	Cover, Dual Vat Drain Safety Switch
7	807-2103	Microswitch, CE Straight Lever
8	816-0220	Insulation, Drain Safety Switch
9	810-1165	Washer, Teflon Drain Valve
10	809-0196	Washer, 3/8-inch Flat
11	106-2671	Bracket Assembly, Dual-Vat Drain Safety Switch
12	810-1114	Valve, 1-inch Dual-Vat Drain
13	809-0540	Nut, 1/2-13 2-Way Hex Lock
14	824-1602	Handle, Full-Vat Drain Valve
15	816-0639	Sleeve, Red Handle
16	806-8137	Bracket Assembly, Full-Vat Drain Safety Switch
17	810-1018	Valve, 1.25-inch Full-Vat Drain
18	200-6496	Support, 3" Drain
19	900-2936	Retainer, Full-Vat Drain Valve Nut
20	816-0135	Round Drain O-Ring
*	WIR0572	Wire Bundle, Drain Safety Switch

* Not illustrated.

** See page 8-9 for a standard parts list.

8.4 Electronics and Wiring Components

8.4.1.1 Single Component Box

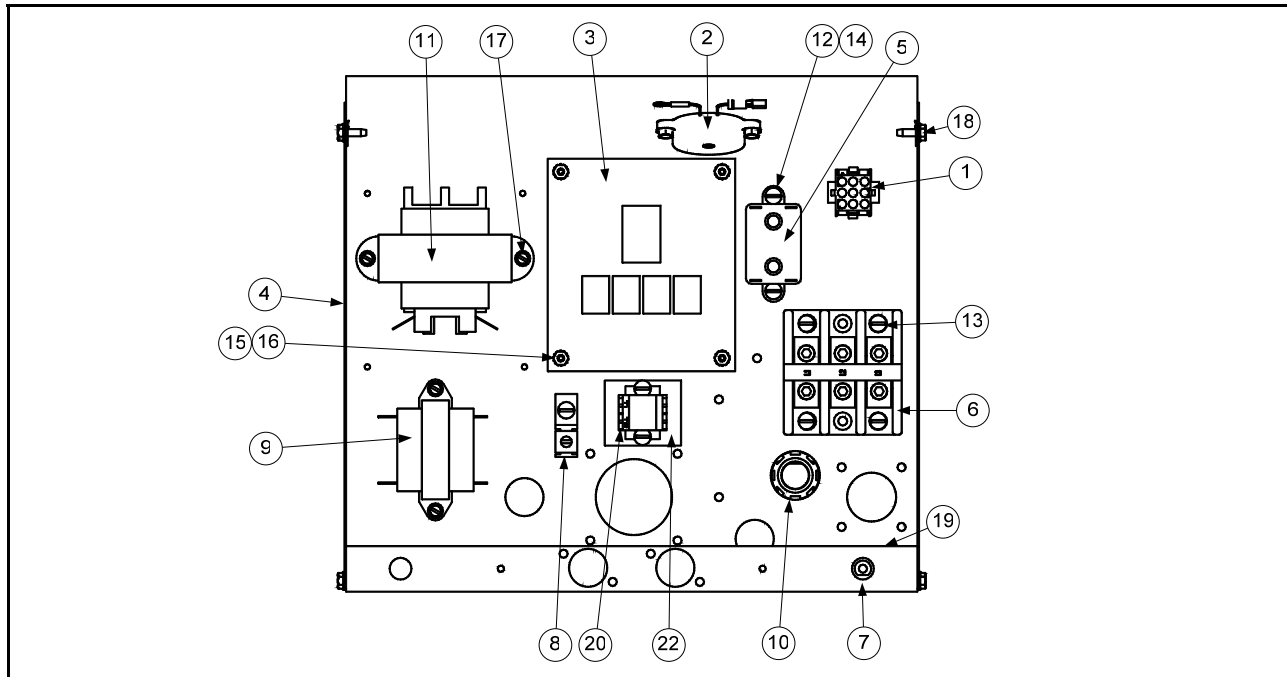

ITEM	STANDARD PART #	EURO-LOOK PART #	COMPONENT
	106-0580		Component Box Assembly Single Navy
1	106-0313		Wire Assembly, Component SFP120
2	806-7179SP		Sound Device
3	806-7935		PCB Assembly, Interface
4	806-9559		Component Box W/ Studs
5	807-0012		Relay, 18AMP 1/3 HP 24V Coil
6	807-0065		Block, Terminal
7	807-0069		Circuit Breaker, 10A
8	807-0070		Terminal, Ground Lug
9	807-0855		Transformer, 120V 50/60 – 12V 20A
10	807-1612		Clamp, 3/8 Connector Type (Thin Screw)
11	807-2181		Transformer, Power 100-120V/24V 62VA
12	809-0102		Screw, 8 – 32 x 3/8 TR SL HD ZP
13	809-0104		Screw, 8 – 32 x 1/2 TR SL HD ZP
14	809-0247		Nut, 8 – 32 Hex KEPS ZP
15	809-0250		Nut, 6 – 32 Hex KEPS ZP
16	809-0349		Spacer, 4mm x 6mm Aluminum
17	809-0360		Screw, 8 x 3/8 Type 8 Hex Washer SL HD ZP
18	826-1374		Screw, #10 – 1/2 Hex Head (Pkg. of 25)
19	810-0045		Bushing, .875 Dia Hole 11/16
20	810-1164		Block, 1 Plc Screwless Terminal
21	812-0368		Conduit, Flex 3/8"
22	816-0217		Paper, Insulating Terminal Block CE
23	WIR-0428		Wire Assembly, Navy SFP Component
24	WIR-0581		Wire Assembly, Transformer 440V

Use standard part.

8.4.1.2 Multiple Vat Component Boxes

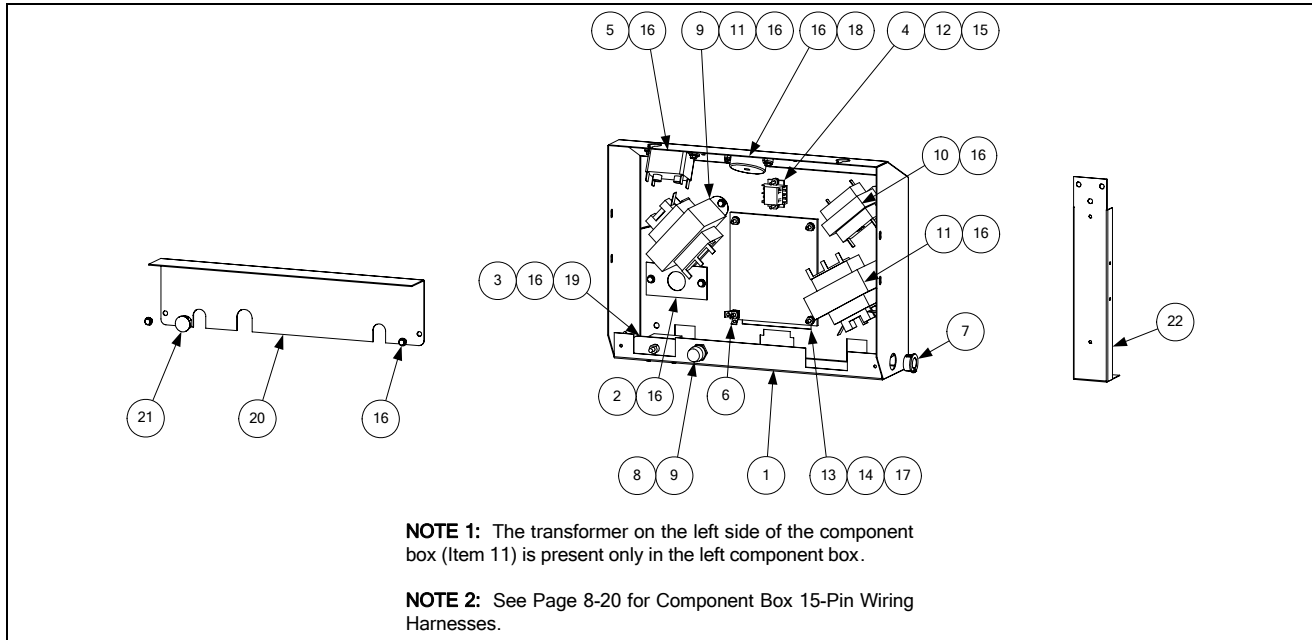

ITEM	STANDARD PART #	EURO-LOOK PART #	COMPONENT
	106-2458		Assembly, Component Box w/ filter
	106-2449		Assembly, Component Box without filter
1	106-1531		Box, Component
2	200-3300		Bracket, Component Box Strain Relief
3	200-3746		Bracket, Circuit Breaker
4	806-9495SP		Terminal Block and Wire Assembly
5	807-0012		Relay, 18 Amp 1/3 HP 24V Coil
6	826-1337		Terminal, 1/4-inch Push-on (Pkg. of 5)
7	807-0121		Bushing, Heyco Plastic AB-625-500
8	807-1321		Holder, AGC Panel-Mount 1/4-inch Fuse
9	807-1597		Fuse, 3 Amp Slow-Blow
10	807-0855		Transformer, 100-120V/24V 20VA
11	807-2181		Transformer, 100-120V/12V 60VA
12	826-1366		Nut, 4-40 Keps Hex (Pkg. of 25)
13	809-0250		Nut, 6-32 Keps Hex
14	809-0349		Spacer, 4mm X 6mm Aluminum
15	826-1359		Screw, 4-40 X 3/4-inch Slotted Round Head (Pkg. of 25)
16	809-0359		Screw, #8 X 1/4-inch Hex Washer Head
17	806-7935		Interface Board
	807-3932		Relay, 12VDC SPDT 12 Amp
18	806-7179SP		Sound Device
19	807-0069		Circuit Breaker, 10 Amp
20	200-3844		Guard, Finger
21	810-2445		Plug, Button
22	200-3243		Brace, Component Box
*	106-2400		Handle Assembly, FPP Power Shower FV

*Not illustrated.

■ Use standard part.

8.4.2.1 Single Contactor Box

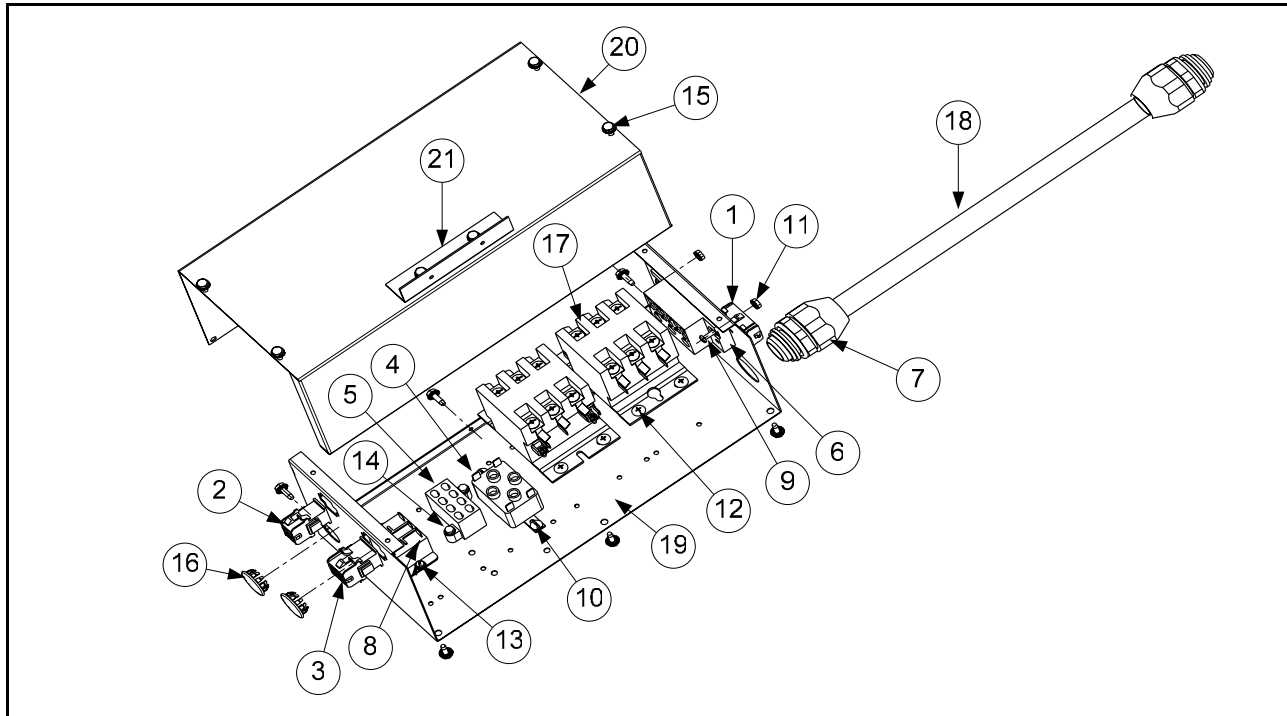

ITEM	STANDARD PART #	EURO-LOOK PART #	COMPONENT
	106-0581		Box, Assembly Contactor Single Navy
1	106-0595		Wire Assembly, CI Single FP
2	806-9628SP		Wire Assembly, HV DV LT Contactor Single
3	806-9629SP		Wire Assembly, HV DV RT Contactor Single
4	807-0012		Relay, 18 AMP 1/3 HP 24V Coil
5	807-0067		Block, Terminal 8 Pin
6	807-0878		Block, Terminal 3 Lug 12 P
7	807-1338		Fitting, Plastic 3/4 Dia Conduit
8	807-1683		Relay, 12 VDC
9	809-0096		Screw, 6 – 32 x 5/8 Bindings SL HD ZP
10	809-0102		Screw, 8 – 32 x 3/8 TR HD ZP
11	809-0250		Nut, 6 – 32 KEPS HX ZP
12	809-0266		Screw, 10- 1/2 Phil TR HD ZP
13	809-0360		Screw, 8 x 3/8 HX Washer SL HD ZP
14	809-0362		Screw, Drill #8 x 1 1/4 Hex Washer HD ZP
15	826-1374		Screw, #10-1/2 Hex Head (Pkg. of 25)
16	810-0044		.875 Plug Button
17	810-1202		Contactor, 40 AMP 600V 3 Pole
18	812-0971		Conduit, 3/4 x 12 LG Flexible
19	900-8608		Box, Contactor Common El. Single FP
20	900-8609		Cover, Contactor Box Common El. Single FP
21	900-8647		Bracket, Contactor Box Single FP
22	WIR0427		Wire Assembly, Navy Single FP

Use standard part.

8.4.2.2 Multiple Vat Contactor Boxes

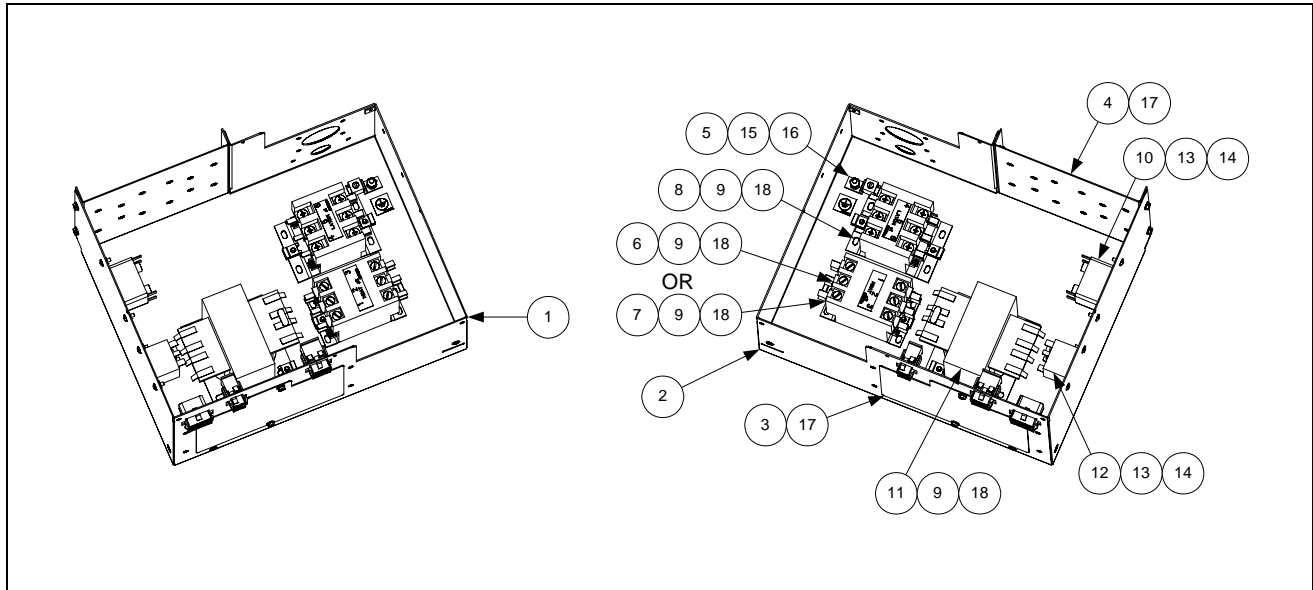

NOTE 1: Left and right contactor box assemblies are mirror images of one another. With the exception of the box itself, all components of a left-hand assembly, including the lid, are the same as those in the corresponding right-hand assembly and vice versa.

NOTE 2: See Page 8-18 and 8-19 for Contactor Box Wiring Assembly

ITEM	STANDARD PART #	EURO-LOOK PART #	COMPONENT
	106-2440		Assembly, Contactor Box Left (<i>Use 106-2442 for H22</i>)
	106-2441		Assembly, Contactor Box Right (<i>Use 106-2443 for H22</i>)
1	106-1536		Box, Left Contactor
2	106-1537		Box, Right Contactor
3	200-4712		Door, Contactor Box w/o Hinge
4	200-2337		Bracket, Contactor Box
5	807-0070		Terminal, Ground Lug
6	807-2284		Contactors, 24V 50 Amp Mechanical (<i>used in 14 & 17kW units only</i>)
7	807-2283		Contactors, 24V 63 Amp Mechanical (<i>used in 22kW units only</i>)
8	810-1202		Contactors, 24V 40 Amp 3-Pole
9	809-0448		Clip, Tinnerman
10	807-0012		Relay, 18 Amp 1/3 HP 24V Coil
11	807-0064		Transformer, 480V/120V 150VA
12	807-1683		Relay, 12VDC
13	826-1358		Nut, 6-32 Keps Hex (Pkg. of 25)
14	826-1365		Screw, 6-32 X 3/8-inch Slot Head (Pkg. of 25)
15	809-0123		Screw, #10 X 3/4-inch Slot Head
16	826-1376		Nut, 10-32 Keps Hex (Pkg. of 10)
17	809-0360		Screw, #8 X 3/8-inch Hex Washer Slot Head
18	826-1374		Screw, #10 X 1/2-inch Hex Head (Pkg. of 25)
*	200-5627		Lid, Left or Right Contactor Box
*	807-2240		Fuse, 60 AMP 300VAC (replaced 45 AMP)
*	807-0501		Fuseholder block

* Not illustrated.

■ Use standard part.

8.4.3 Heating Element Assembly and Associated Parts

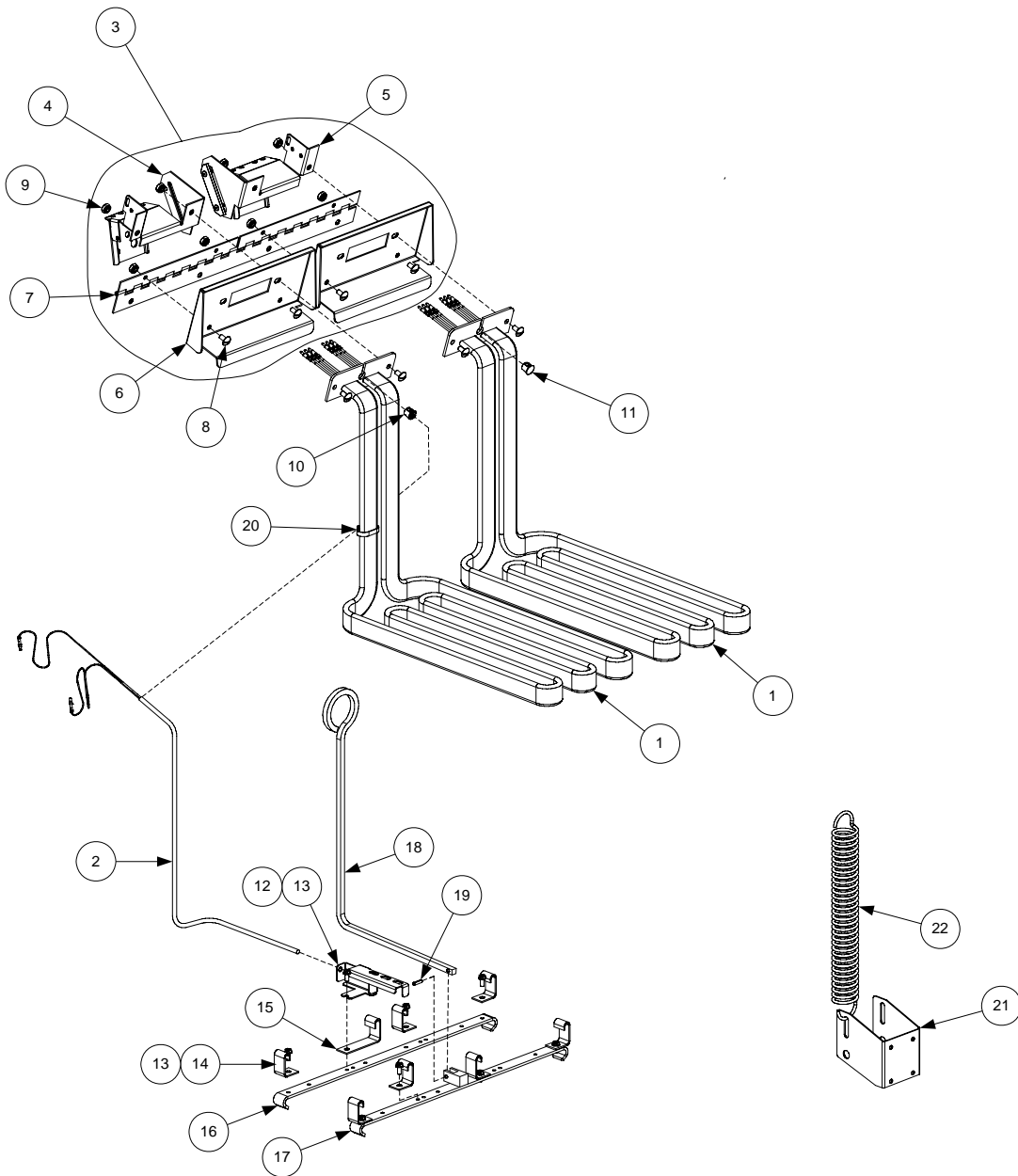

NOTES:

The only difference between element assemblies for different voltage and kW ratings is the element itself (Item 1)

Items 21 and 22 are shown as associated parts. They are not part of the element assembly.

8.4.3 Heating Element Assembly and Associated Parts (cont.)

ITEM	STANDARD PART #	EURO-LOOK PART #	COMPONENT
1			Element
	807-2649		440V 7.0 kW
	807-2650		440V 8.5 kW
	807-3176		440V 11.0 kW
	807-2651		480V 7.0 kW
	807-2652		480V 8.5 kW
	807-3177		480V 11.0 kW
2	826-1526		Probe, Temperature
3	106-0004SP		Tilt Plate Assembly
4	106-0572SP		Bracket, Left Spring Slot
5	106-0573SP		Bracket, Right Spring Slot
6	910-9641		Tilt Plate
7	810-0035		Hinge
8	826-1330		Screw, 10-32 X 3/8-inch Slotted Truss Head (Pkg. of 25)
9	826-1376		Nut, 10-32 Keps Hex (Pkg. of 10)
10	826-1339		Bushing, .375-inch Split (Pkg. of 10)
11	816-0480		Plug, .375-inch Dome
12	910-5022		Bracket, Temperature Probe
13	809-0518		Screw, 8-32 X 3/8-inch Slotted Hex Head
14	910-2042		Clamp, Element (Short)
15	910-5213		Clamp, Element (Long)
16	910-3681		Support, Full-Vat Element Rear
17	823-2377		Support, Full-Vat Element Front
18	810-1233		Handle, Element Lift
19	810-1212		Pin, .125 X .5-inch Split
20	809-0567		Tie-Wrap, Metal
21	200-2060		Bracket, Lower Spring Slot
22	810-0297		Spring, Element

■ Use standard part.

8.4.4 Controller

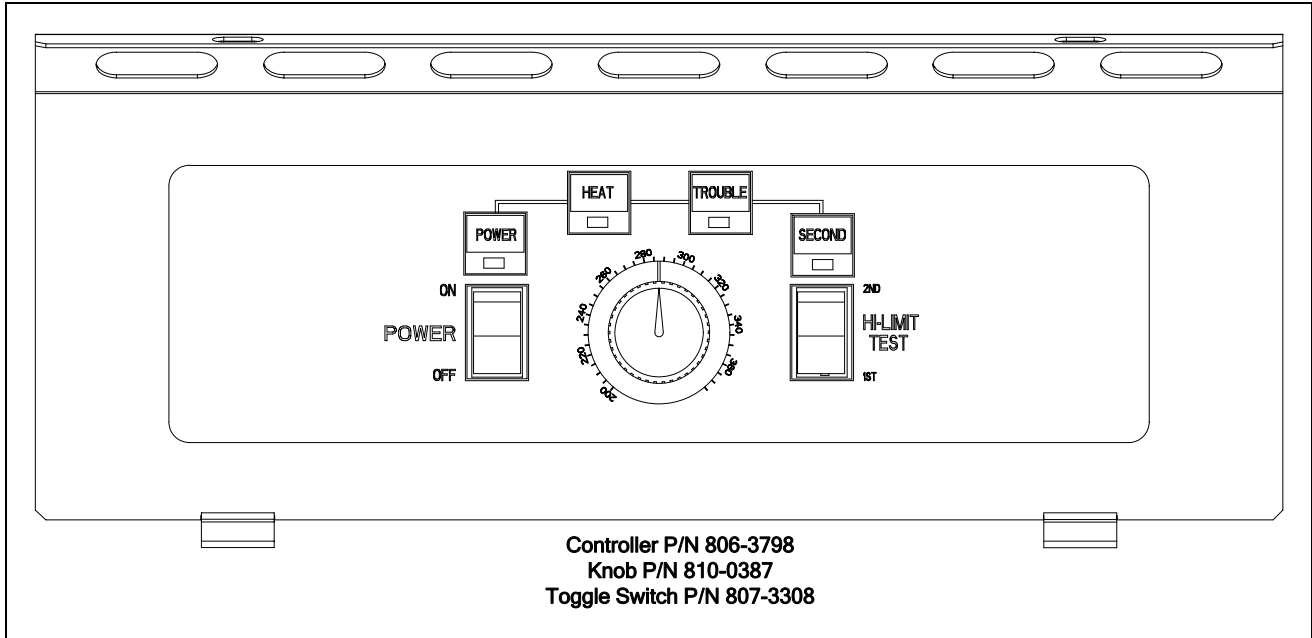

8.4.5 Wiring

8.4.5.1 Contactor Box Wiring Assembly – 12-Pin Full-Vat C-1

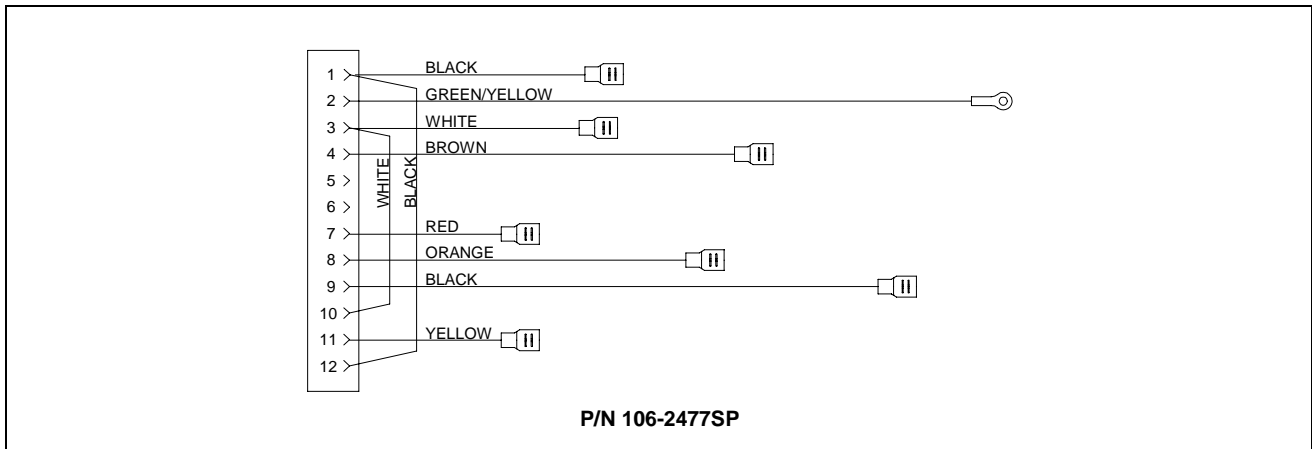

8.4.5.2 Contactor Box Wiring Assemblies – 6-Pin (Left Element)

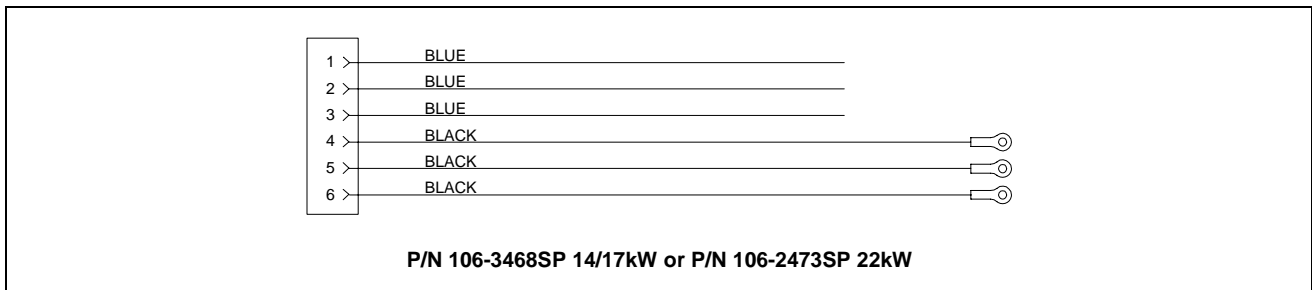

8.4.5.3 Contactor Box Wiring Assemblies – 9-Pin (Right Element)

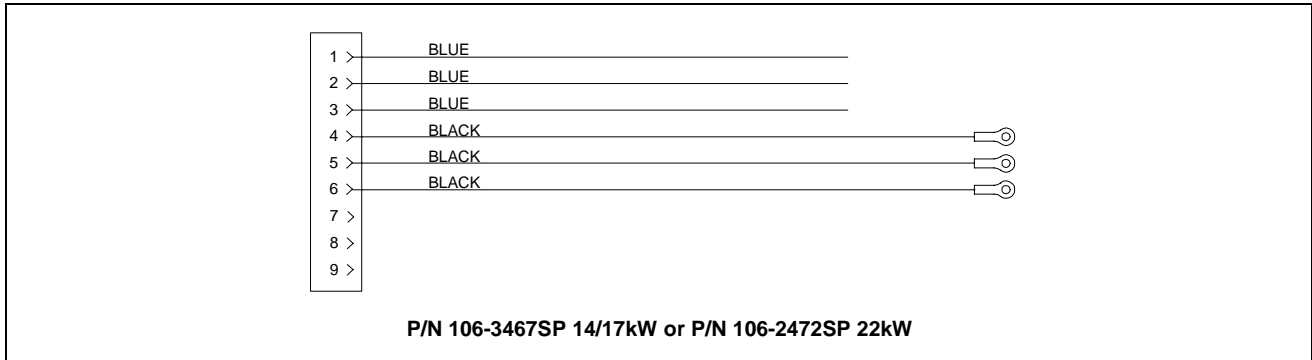

8.4.5.4 Single Contactor Box Wiring Assembly

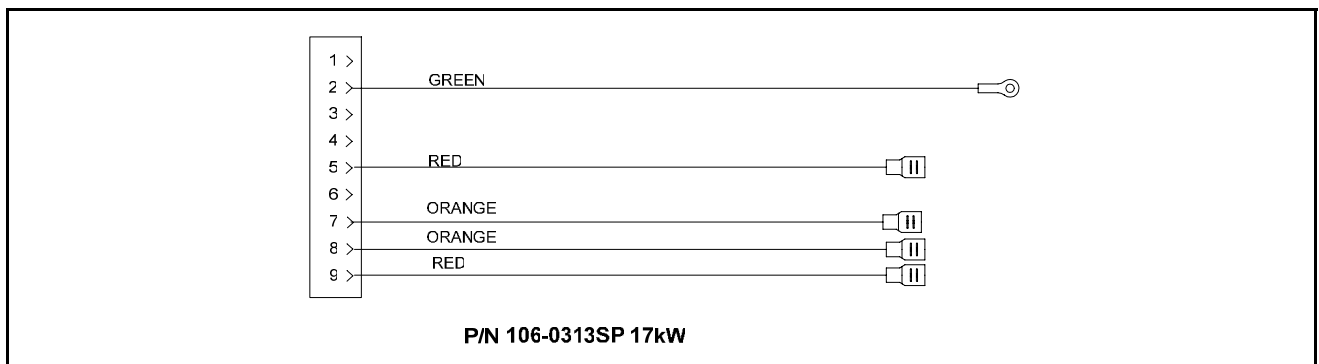

8.4.5.5 Main Wiring Harness

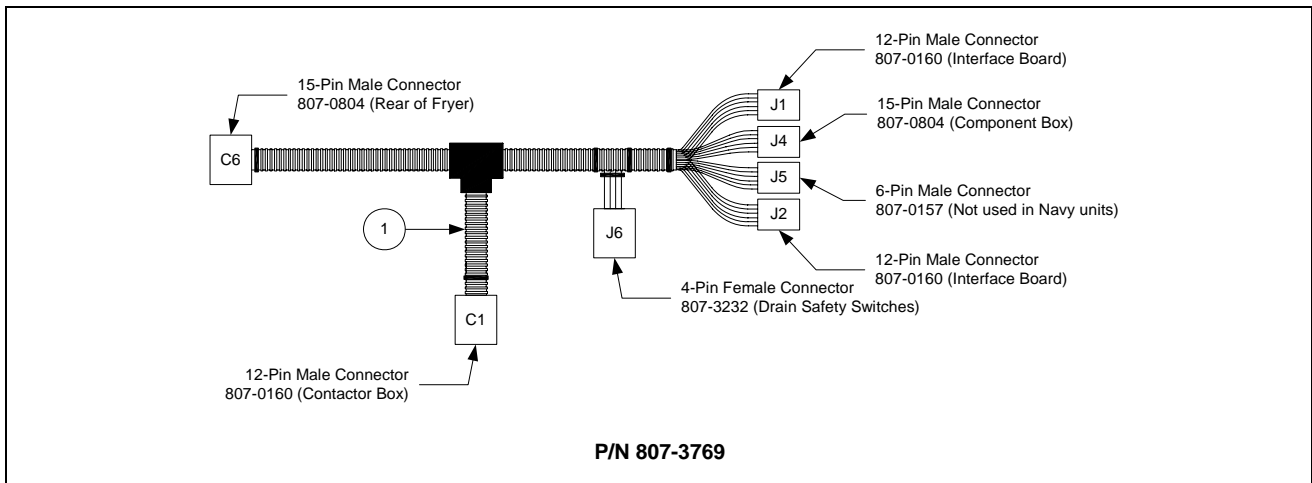

8.4.5.6 Single Main Wiring Harness

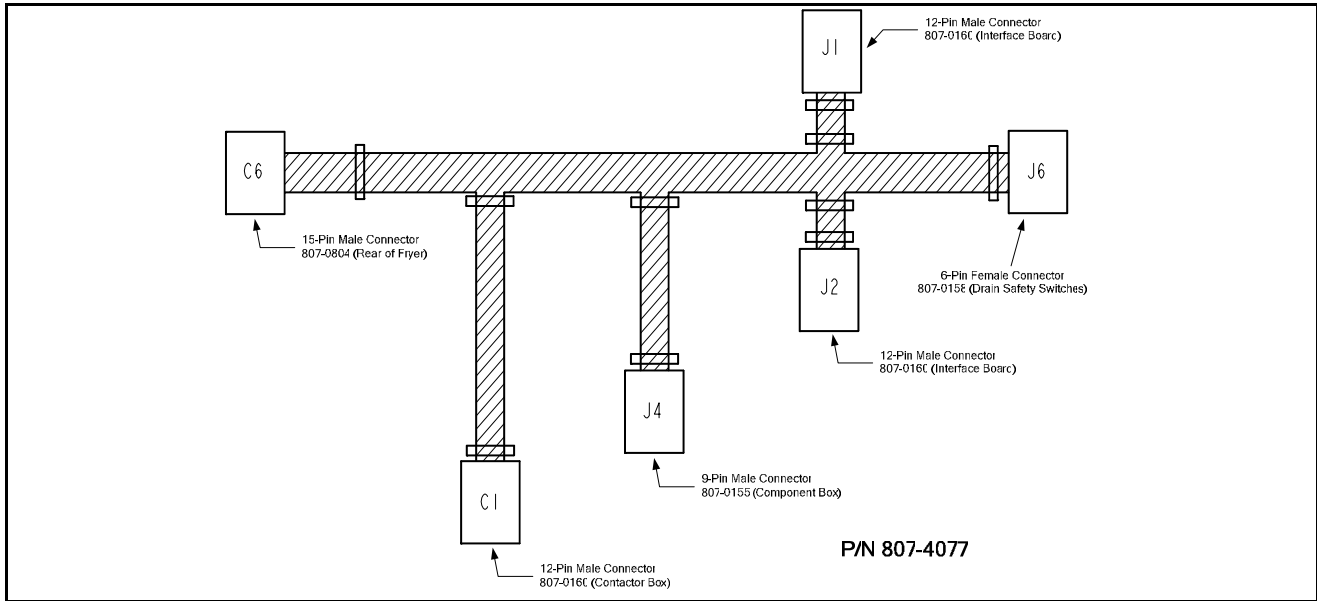

8.4.5.7 Component Box Wiring Harness – 15-Pin

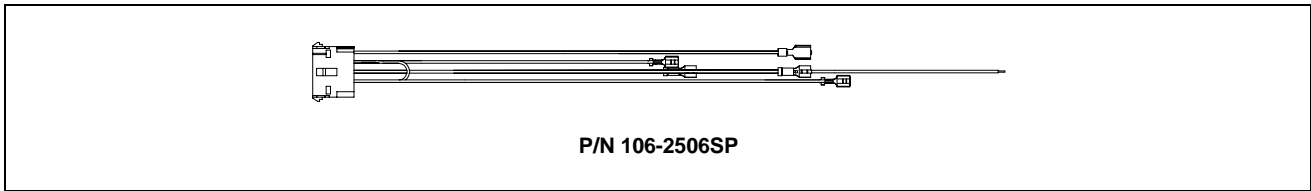

8.4.5.8 Single Component Box Wiring Harness – 15-Pin

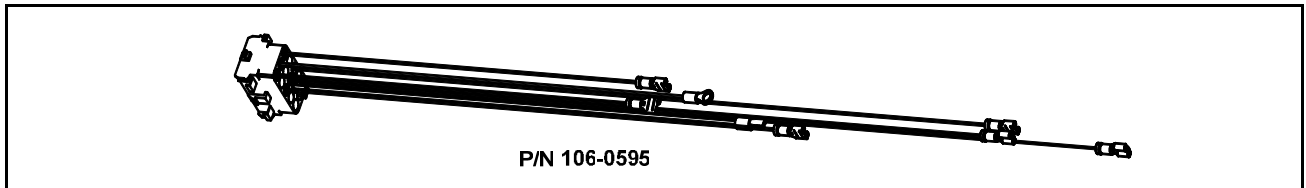

8.4.5.9 Single Component Box Wiring Harness – 15-Pin without Filter

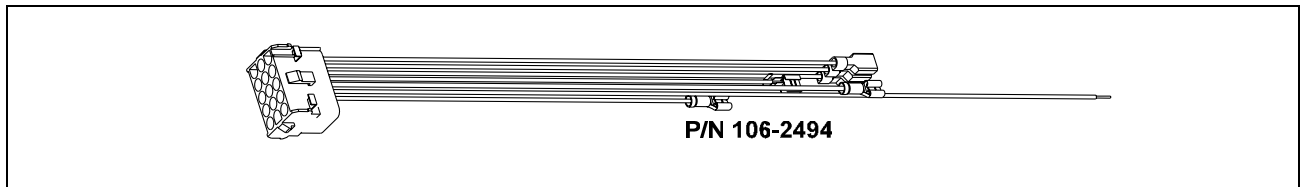

8.4.5.10 Interface Board to Controller Wiring Harness – 15-Pin

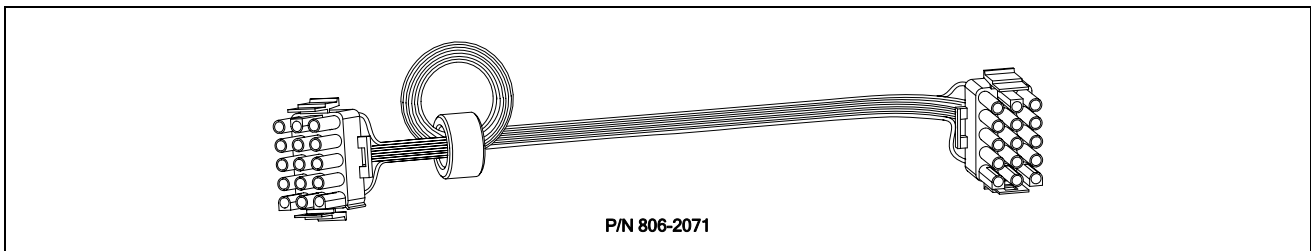

8.5 Filtration System Components

8.5.1 FPH117/122 Filtration Components

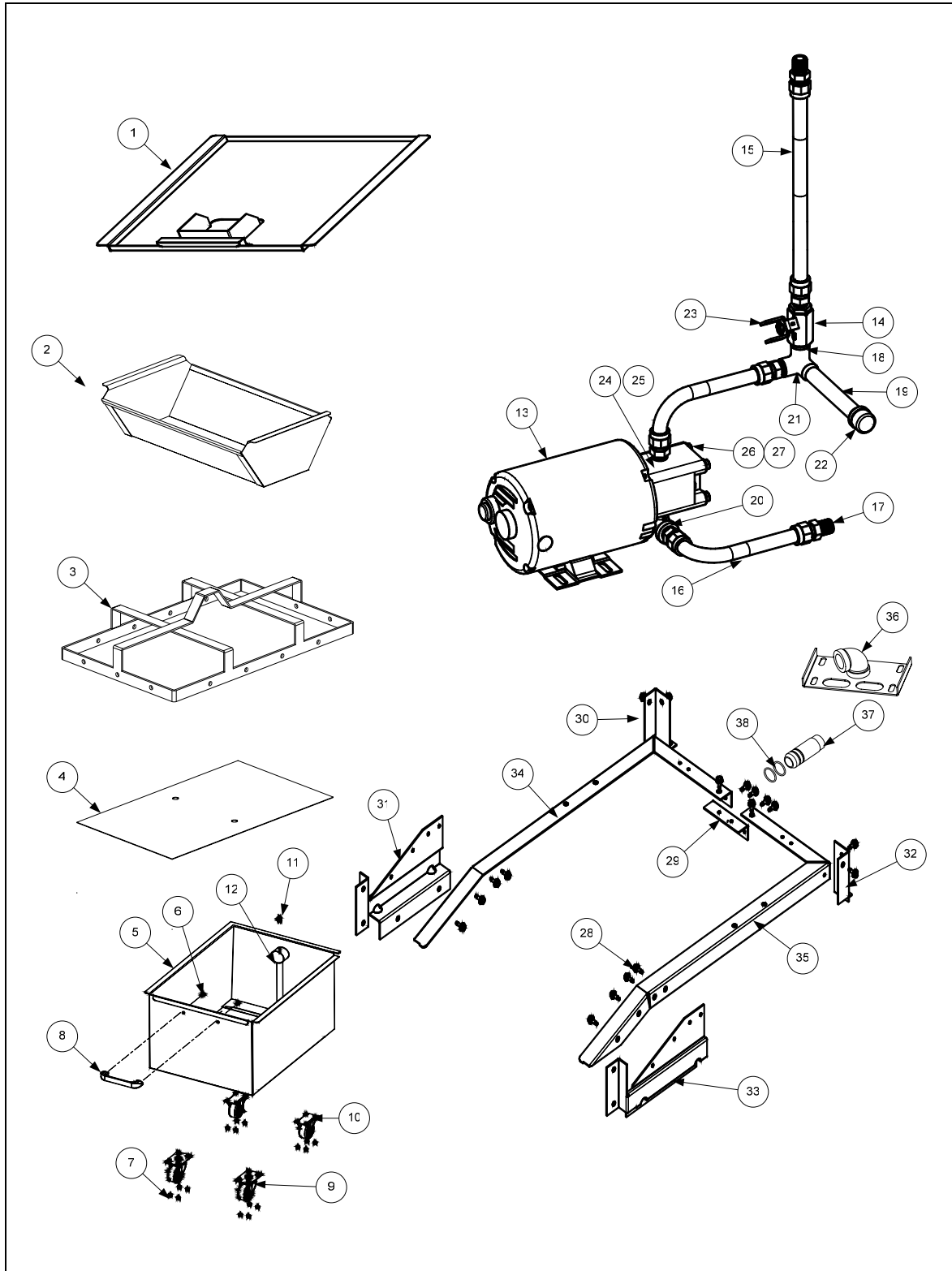

8.5.1 FPH117/122 Filtration Components (cont.)

ITEM	PART #	EURO-LOOK PART#	COMPONENT
	806-9546SP	106-4945	Assembly, Filter Pan FPH117
1	806-9547		Lid, Single FPH117
2	810-2743		Crumb Tray
3	823-2899		Hold Down Ring
4	900-8933		SanaGrid Filter Screen
5	823-2828	823-5141	Pan, Filter
6	826-1360		Screw, 10-24 x 5/16 RD SL HD ZP (Pkg. of 25)
7	826-1376		Nut, KEPS, 10 – 32 HX ZP (Pkg. of 10)
8	810-0180		Handle, Door
9	810-2805		Caster, 2” Filter Pan
10	810-2807		Caster, 2” Rigid
11	813-0568		Pipe Plug 1/8 NPT Socket Head
12	823-5142		Tube, Pan Suction Single FP
	106-4976		Plumbing Assembly, FV Single FP
13	826-1712		Kit, Motor and Gasket 115V (807-3859 Motor)
14	810-2944		Gemini Valve without Handle
15	810-1057		Flex Line 5/8” O.D. x 13” Long
16	810-1067		Flex Line 5/8” O.D. x 8.5” Long
17	810-1668		Adapter, Male 7/8” O.D. x 1/2”
18	813-0022		Nipple, 1/2” x Close N.P.T. B.M.
19	813-0098		Nipple, 1/2” x 6.50” N.P.T. B.M. Pipe
20	813-0616		Elbow, ST 1/2” x 1/2” NPT 90° BM
21	813-0331		Elbow, W/Side Outlet – 1/2” NPT
22	813-0469		Cap, Pipe 1/2” BM
23	210-9197		Handle, Right RF Valve
24	826-1264		Kit, Pump and Gasket, Viking 4 GPM 2-piece
25	816-0093		Gasket, Pump / Motor
26	809-0514		Cap Screw, 5/16” – 18 NC SAE Grade 5, HX HD
27	809-0194		Washer, Flat 5/16” SAE ZP
	106-4951		Rail Assembly, Filter Pan Single FPH117
28	809-0500		Screw, 10 – 1/2” HX HD SS
29	210-9145		Angle, Joining, Pan Rails Filter Magic
30	211-9147		Leg, Pan Rail FM Left
31	211-9146		Bracket, Attaching Filter Pan Left
32	212-9147		Leg, Pan Rail FM Right
33	212-9146		Bracket, Attaching Filter Pan Right
34	211-9455		Rail, Filter Pan Left
35	212-9455		Rail, Filter Pan Right
36	823-5151		Mount W/A, Male Connector
37	810-0697		Disconnect, Filter Pan Connection (Male)
38	826-1392		O-Ring, Filter Pan Connection (Pkg. of 5)

Use standard part.

8.5.2 FPH217/317 Multiple Battery Filtration System Components

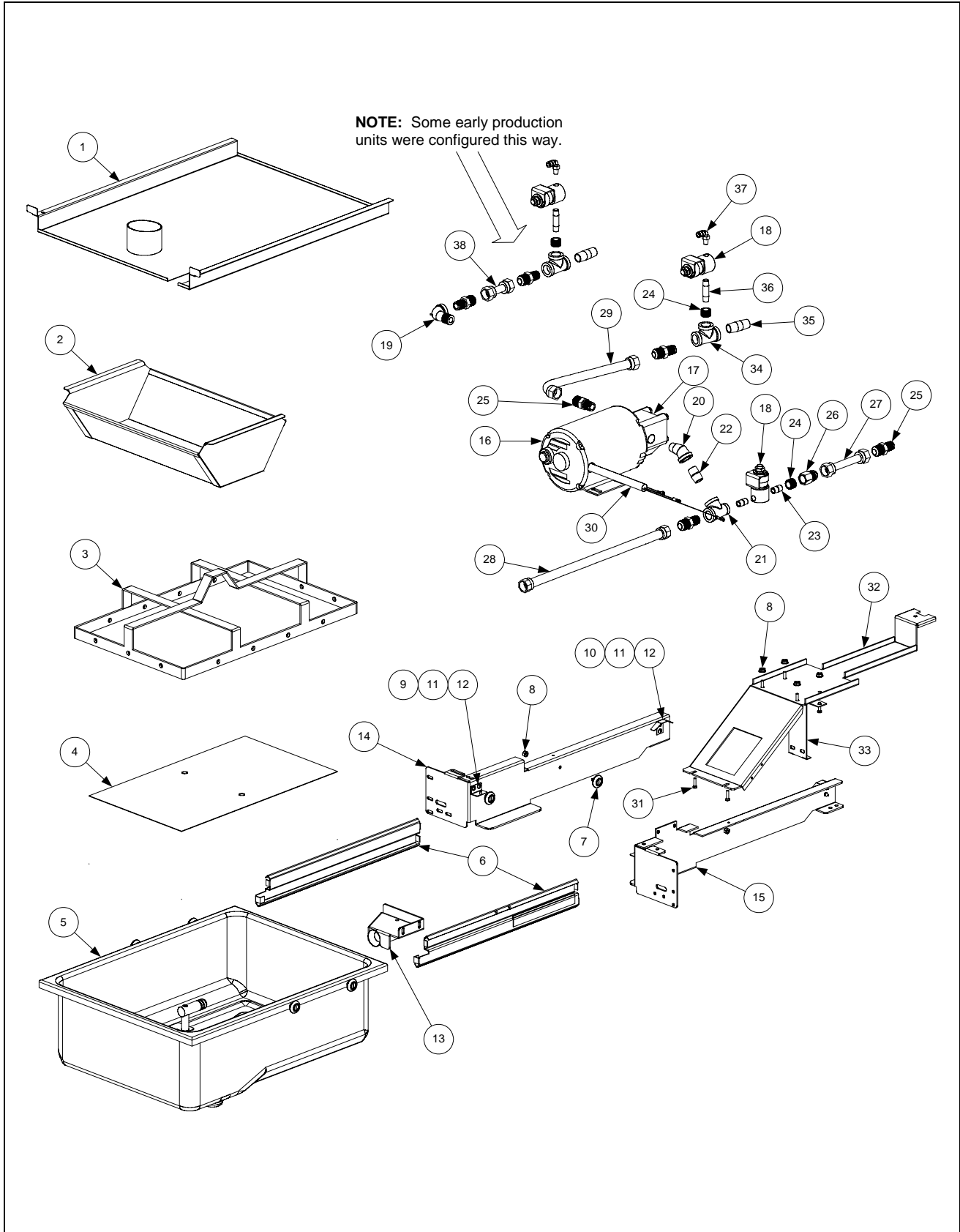

8.5.2 FPH217/317 Multiple Battery Filtration System Components (cont.)

ITEM	STANDARD PART #	EURO-LOOK PART #	COMPONENT
*	826-1979		Filter Pan Roller Kit (four each of Items 7 and 8)
*	826-1980		Service Filter Pan (Item 5 minus Item 2)
*	826-1981		Service Filter Pan Assembly (Service Filter Pan above plus Items 3 & 4)
*	826-1392		O-Ring (Pkg. of 5; used with Item 5)
*	813-0568		Plug, 1/8-inch Socket Head Pipe (component of Item 5; two required)
*	811-1071		Tubing, 1/4-inch OD Teflon Vent (sold by the foot)
*	806-5933SP		Heater Strip Assembly, 120V 18" 25W
1	823-4637	823-4787	Lid (<i>for units built before Feb 04, use 823-4391</i>)
2	810-2743		Crumb Tray (component of Item 5)
3	810-2091		Hold Down Ring
4	200-2124		SanaGrid Filter Screen
5	106-2617SP		Pan, One-Piece Filter (includes Item 2 and o-rings)
6	810-2012		Rail Set, Filter Pan Roller (includes one left and one right)
7	810-2198		Roller, Filter Pan and Rail
8	826-1372		Nut, 1/4-20 Hex (Pkg. of 10)
9	823-4589	823-4675	Bracket, Lid Support (<i>for units built before Feb 04, use 823-3875</i>)
10	200-3556		Guide, Filter Pan Lid
11	809-0104	809-0503	Screw, 8-32 X 1/2-inch Slotted Truss Head
12	809-0247		Nut, 8-32 Hex Keps
13	823-3879		Suction Tube
14	200-4408		Rail, Left Filter
15	200-4409		Rail, Right Filter
16	826-1712		Kit, Motor and Gasket 115V 60Hz (807-3859 Motor)
17	826-1264		Pump and Gasket Kit
18	807-2484		Valve, 1/4-inch Solenoid
19	813-0165		Elbow, 1/2-inch 90° Street
20	813-0342		Elbow, 1/2-inch 45° Street
21	813-0530		Tee, 1/2-inch X 1/4-inch X 1/2-inch Reducing
22	813-0022		Nipple, 1/2-inch Close
23	813-0838		Nipple, 1/4-inch Close
24	813-0304		Bushing, 1/2-inch to 1/4-inch Flush
25	810-1668		Adapter, 5/8-inch to 1/2-inch NPT Male
26	810-1669		Adapter, 5/8-inch to 1/2-inch NPT Female
27	810-1159		Flexline, 5.0-inch Oil Return
28	810-1369		Flexline, 17.5-inch Oil Return
29	810-1055		Flexline, 11.5-inch Oil Return
30	807-3828		Cable, FootPrint Pro Pump Motor
31	826-1375		Screw, 10-32 X 3/4-inch Hex Trim Head (Pkg. of 5)
32	200-5950		Bridge, Filter Motor
33	210-3149		Support, Contactor Box
34	813-0003		Tee, 1/2-Inch
35	813-0298		Nipple, 1/2-inch 2.0-inch
36	813-0537		Nipple, 1/4-inch 2.0-inch
37	810-2493		Fitting, 1/4-inch X 90° Quick-Connect
38	810-1160		Flexline, 3.0-inch Oil Return
*		810-1043	Flexline, 9.5-inch Oil Return
*		810-1057	Flexline, 13.0-inch Oil Return

* Not illustrated.

■ Use standard part.

8.6 Frypot Assembly and Thermostat

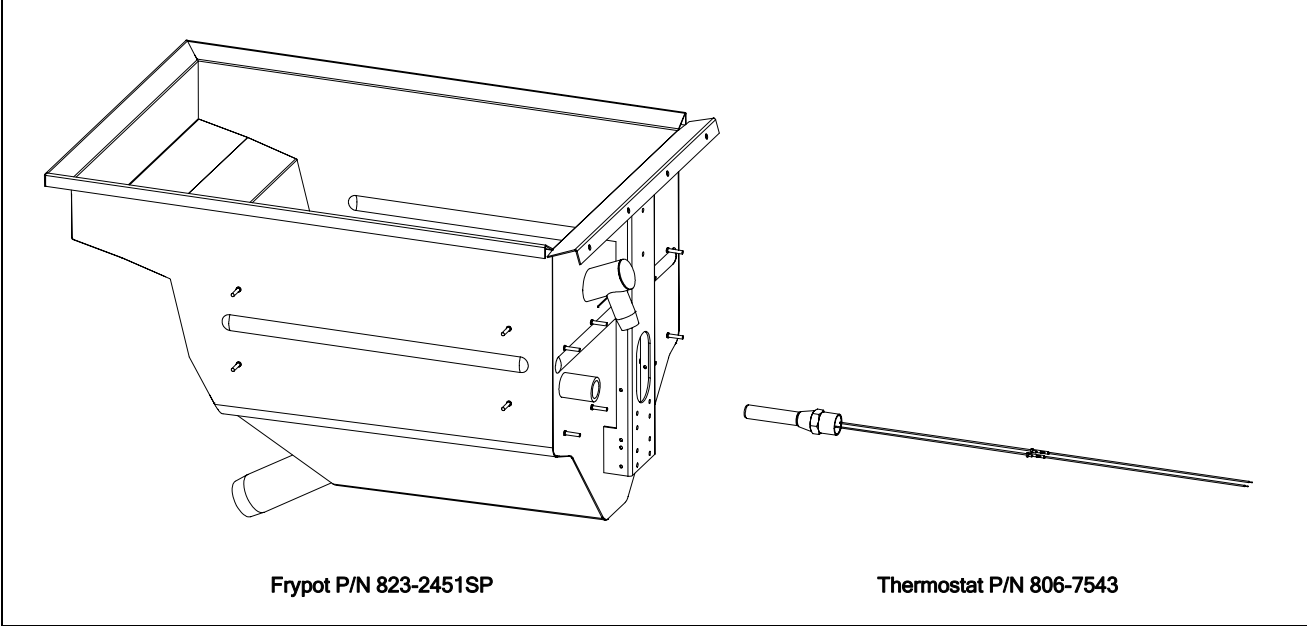

8.7 Oil Return System Components

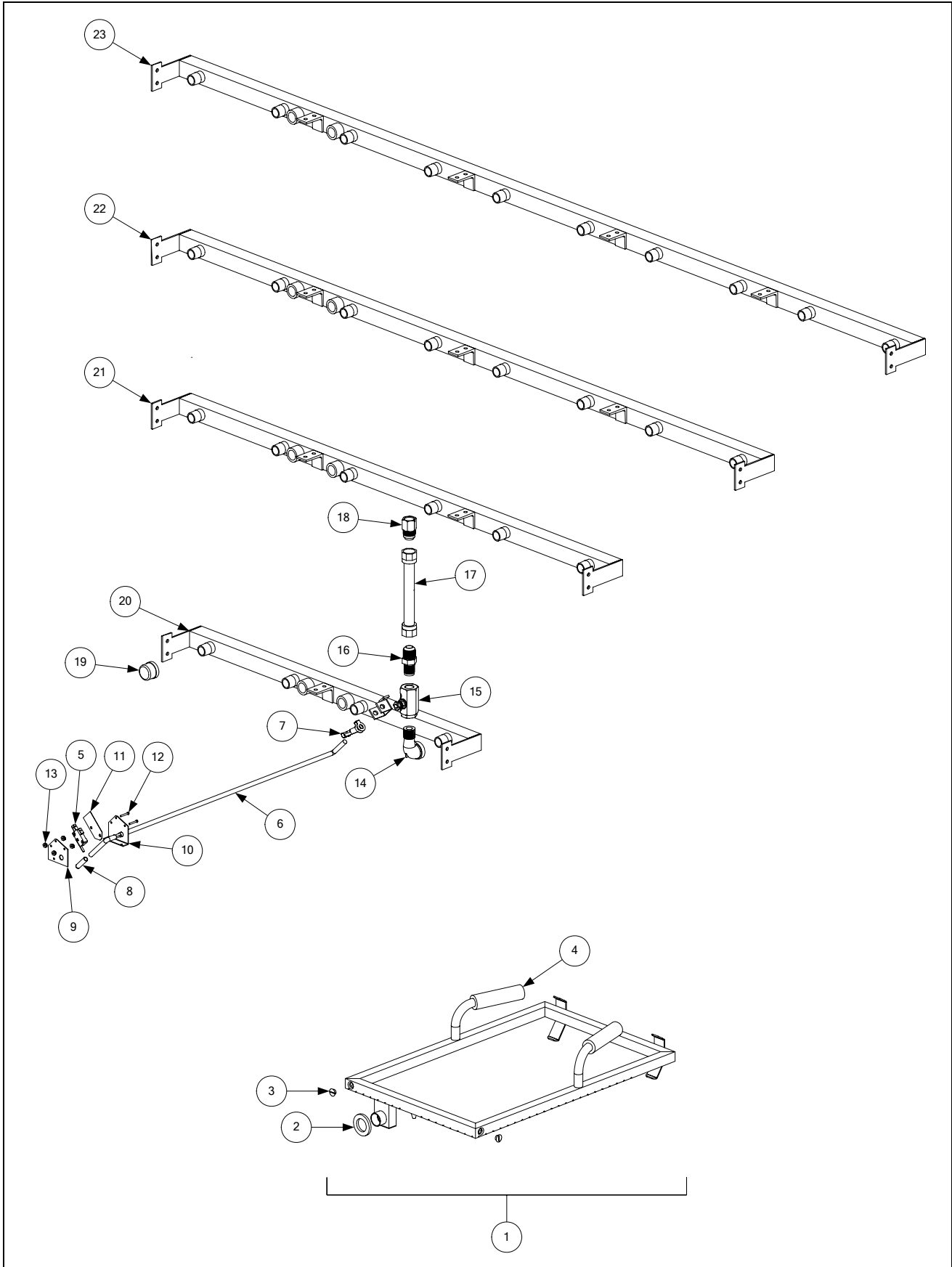

8.7 Oil Return System Components (cont.)

ITEM	STANDARD PART #	EURO-LOOK PART #	COMPONENT
1	806-4505SP		Power Shower Assembly, Full-Vat
2	826-0992		Seal, Power Shower (Pkg. of 3)
3	809-0415		Screw, Power Shower Cleanout
4	814-0001		Grip, Power Shower Handle
5	807-2103		Microswitch, Oil Return
6	810-2330		Handle, Oil Return Valve
7	809-0601		Clip, Clevis
8	810-0677		Grip, Oil Return Valve Handle
9	200-5401		Bracket, Handle Retainer
10	106-3349		Bracket, Oil Return Microswitch
11	816-0220		Insulation, Oil Return Microswitch
12	826-1359		Screw, 4-40 X 3/4-inch Slotted Pan Head (Pkg. of 25)
13	826-1366		Nut, 4-40 Keps Hex (Pkg. of 25)
14	813-0165		Elbow, 1/2-inch X 90° Street
15	810-0278		Valve, 1/2-inch Ball
16	810-1668		Adapter, 5/8-inch to 1/2-inch NPT Male
17	810-1680		Flexline, 6.5-inch
18	810-1669		Adapter, 5/8-inch to 1/2-inch NPT Female
19	813-0469		Cap, 1/2-inch NPT Pipe
20	810-2255		Manifold, Two-Station Fryer
21	810-2256		Manifold, Three-Station Fryer
22	810-2257		Manifold, Four-Station Fryer
23	810-2312		Manifold, Five-Station Fryer

■ Use standard part.

8.8 WIRING CONNECTORS, PIN TERMINALS, AND POWER CORDS

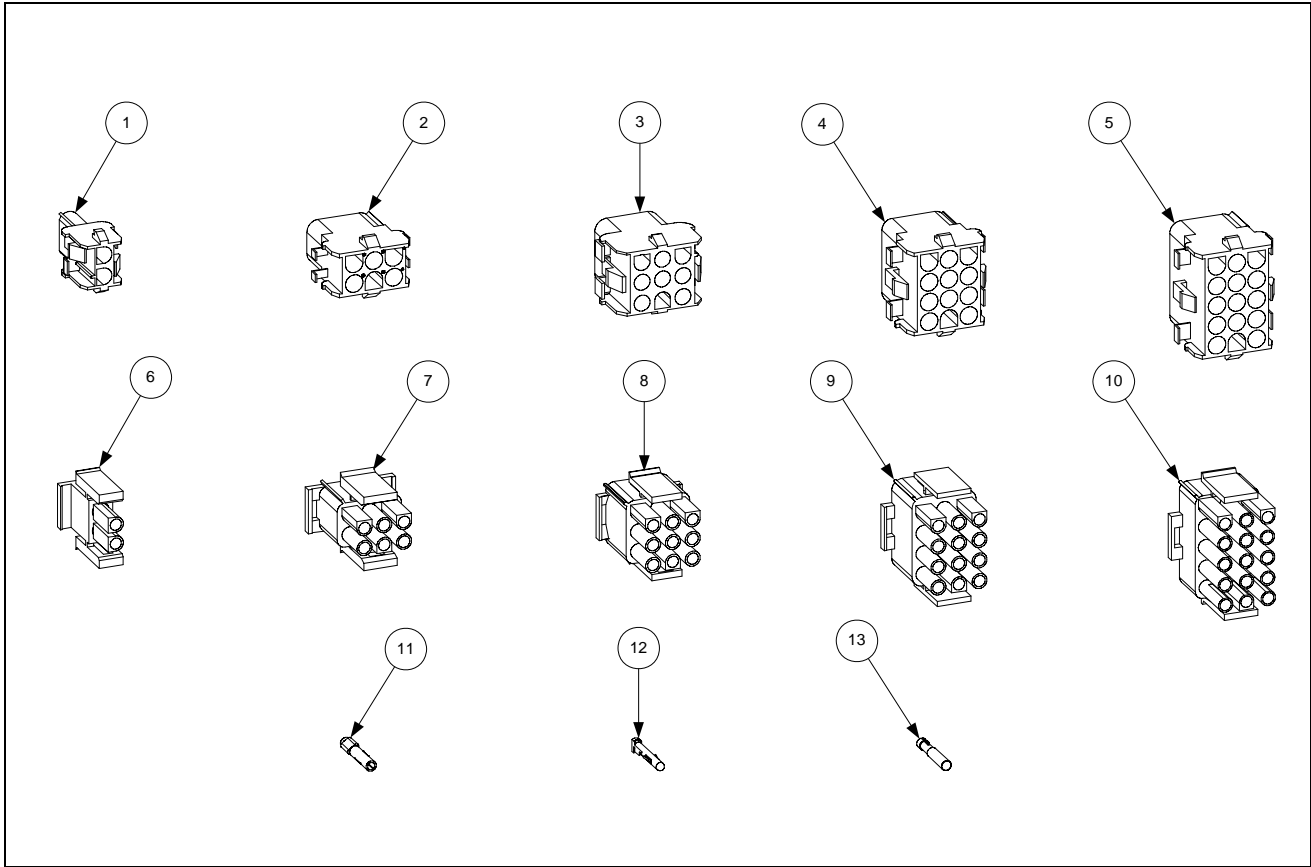

ITEM	STANDARD PART #	EURO-LOOK PART #	COMPONENT
			Power Cords
*	807-3834		Cable, 3-Phase 4-Wire (Fryer Power Cable)
*			Cord, Filter System Power
			Connectors
1	807-1068		2-Pin Female
2	807-0158		6-Pin Female
3	807-0156		9-Pin Female
5	807-0159		12-Pin Female
5	807-0875		15-Pin Female
6	807-1067		2-Pin Male
7	807-0157		6-Pin Male
8	807-0155		9-Pin Male
9	807-0160		12-Pin Male
10	807-0804		15-Pin Male
11	826-1341		Terminal, Female Split Pin (Pkg of 25)
12	826-1342		Terminal, Male Split Pin (Pkg of 25)
13	807-2518		Plug, Mate-N-Lock (Dummy Pin)

* Not illustrated.

■ Use standard part.