



PF50 Portable 50-lb. Capacity Oil Filters

Project _____
 Item _____
 Quantity _____
 CSI Section 11400 _____
 Approval _____
 Date _____

PF50 Portable 50-lb. Capacity Oil Filters

Models

PF50S

PF50R



Standard Features

- 50-lb. (25 liter) oil capacity
- S models receive used oil through a gravity drain and actively pump filtered oil back to the frypot
- R models have a reversible pump feature so they actively pump used oil from the frypot and filtered oil back to the frypot
- Fast - filters a 50-lb. fryer in less than 5 minutes
- Simple to use. Easy to clean.
- 4 GPM, 1/3 H.P. heavy-duty motor
- Heated hose eliminates clogging with all oil types
- 5' (152.4 cm) hose with non-heat conducting handle
- Cover and fold-down handle for safe and easy storage

- Durable stainless steel pan and pump housing
- Swivel casters
- Filter starter kit

Options & Accessories

- Crumb tray
- See Frymaster Price List for filter supplies and optional filtering accessories

Specifications

Designed to make daily filtration easy, quick and efficient

Frymaster's durable PF50 portable filters are designed to support routine oil filtration which preserves oil life and maintains consistent fried food quality. Crumbs, sediment, and by-products created by high-heat frying take a toll on oil life unless a daily system of filtration and frypot cleaning is in place.

The filters' powerful 4 GPM, 1/3 H.P. heavy-duty pump circulates the used oil through the filter media to trap the crumbs, sediment, and by-products that compromise flavor profiles and reduce useful oil life. The pump

then returns the clean filtered oil back to the frypot. Cleanup is easy, simply remove the filter media.

The 5' hose returns filtered oil with ease, amply reaching the frypot to wash crumbs from the walls and the bottom of the frypot. The hose heater eliminates clogging with all oil types. R models have a reversible pump so used oil can be pumped from and filtered oil can be returned to the frypot.

PF50 Portable filters fit under the drain of all Frymaster 50-lb fryers.

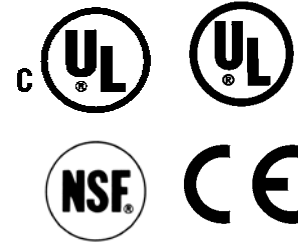

8700 Line Avenue
Shreveport, LA 71106-6800
USA

Tel: 318-865-1711
Tel: 1-800-221-4583
Fax: 318-868-5987
E-mail: info@frymaster.com

www.frymaster.com
Bulletin No. 818-0092
Printed 11/07
Revised 10/13/11



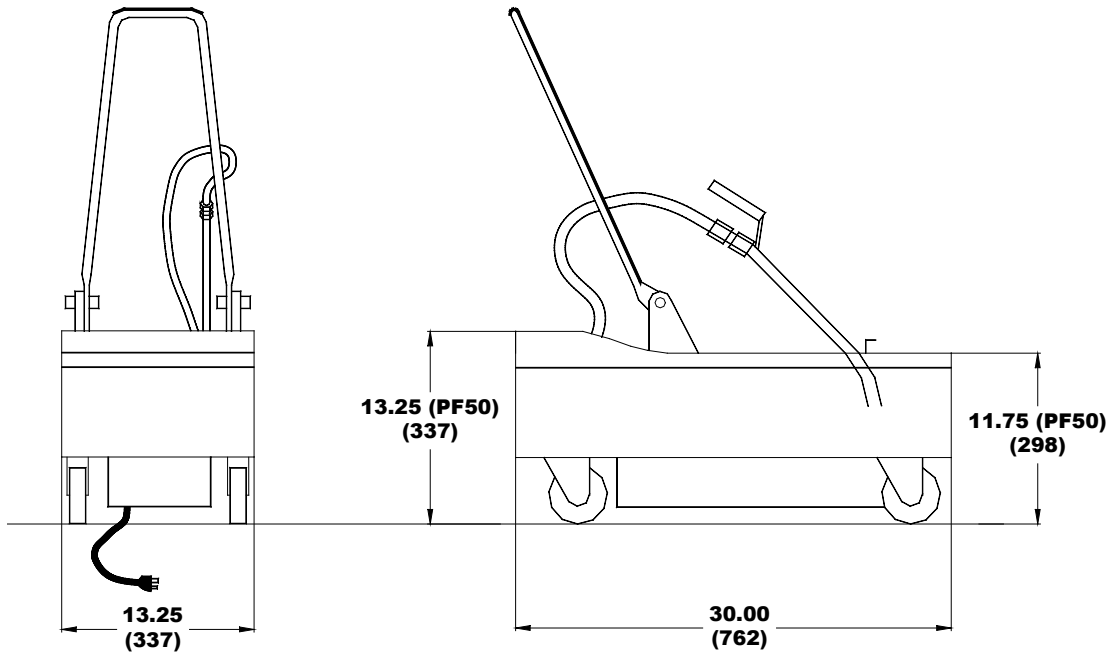

PORTABLE FILTER (PF50 SHOWN)

DIMENSIONS

MODEL NO.	OIL CAPACITY	OVERALL SIZE (cm)			FRONT TANK HEIGHT	APPROXIMATE SHIPPING INFORMATION (cm)					
		WIDTH	DEPTH	BACK TANK HEIGHT		WEIGHT	CLASS	CU. FT.	DIMENSIONS		
PF50S and PF50R	50 lbs. (28 liter)	13-1/4" (33.7)	30" (76.2)	13-1/4" (33.7)	11-3/4" (29.6)	120 lbs. (54.4 kg)	85	7.63	H 25" (63.5)	W 16-3/4" (42.5)	L 31-1/2" (80.0)

POWER REQUIREMENTS

Domestic: 120V - 60 Hz 9 A **Export/CE:** 230 VAC 50 Hz. 5 A

ORDERING DATA

Please specify:
Model number

HOW TO SPECIFY

- PF50S 50-lb. (25 liter) oil capacity portable oil filter with gravity drain
- PF50R 50-lb. (25 liter) oil capacity portable oil filter with reversible pump
- (S) Gravity drain. Pump only returns filtered oil to the frypot.
- (R) Reversible pump. Pumps oil out of and back into the frypot.