

Operations & Service Manual **GGF SERIES**

GGF-400, GGF-720



*Models: GGF-400
GGF-720*



Giles Enterprises, Inc.

An ISO9001 Registered Company • Committed to Quality
2750 Gunter Park Drive West • Montgomery, AL 36109 USA

Fax: 334.239.4117 • Website: www.gfsequipment.com

Service Hotline (Toll Free): 800.554.4537 (USA & Canada Only)

Form No. 65474 (Rev date: 10/12/10)

IN A PROMINENT LOCATION, post instructions to be followed in the event the user smells gas. Such information can be obtained by consulting the local gas supplier.

FOR YOUR SAFETY

Do not store or use gasoline, other flammable liquids, or materials that can generate flammable vapors in the vicinity of this or any other appliance.

WARNING

- **Improper installation, adjustment, alteration, service or maintenance can cause property damage, personal injury, or death.**
- **Read the installation, operating and maintenance instructions thoroughly before installing, operating or servicing this equipment.**



LIMITED WARRANTY

- Subject to the terms and conditions of this Limited Warranty as herein stated, all Giles Enterprises, Inc., Foodservice Equipment and parts purchased new from an authorized Giles Enterprises, Inc., representative are warranted as to defects in material or workmanship for a period of 12 months from the date of installation, provided, however, that with regard to labor costs in connection with this warranty, see below. All installations must be made by a qualified installing agency in accordance with all applicable codes and/or regulations in the jurisdiction in which installed. Limited warranty coverage is extended to the original owner only and is void if the unit is resold.
- During the Limited Warranty period, Giles Enterprises, Inc. will replace or recondition, at its factory, any part or parts of this unit which Giles Enterprises, Inc. inspectors judge defective, provided the unit has been subjected to normal usage, properly installed, operated and serviced. This Limited Warranty does not cover cosmetic damage, and damage due to acts of God, accident, misuse, alteration, negligence, abuse of the Giles Foodservice Equipment or the use of unorthodox repair methods. All parts replaced under this Limited Warranty carry only the unexpired term of this Limited Warranty. Limited Warranty service may be furnished only by an authorized Giles Enterprises, Inc., representative.
- If Limited Warranty service is requested, Giles Enterprises, Inc., will send factory-authorized service representatives to repair, recondition, replace or inspect units of its manufacture with such labor being rendered without cost to owner for ninety (90) days from the date of installation. Otherwise, service, including labor and transportation charges or other expenses, in connection with the removal or installation of any part or parts supplied under this Limited Warranty, are specified on the original sales contract between the purchaser and the authorized Giles Enterprises, Inc., representative.
- Giles Enterprises, Inc. reserves the right to change or improve its equipment and parts in any way without obligation to alter such equipment or parts previously manufactured.
- Giles Enterprises, Inc. makes no further warranties, express or implied including implied warranties of merchantability or fitness for a particular purpose, and has no other obligation or liability not specifically stated herein.
- Repair or replacement as provided under this limited warranty is the exclusive remedy. Giles Enterprises, Inc., shall not be liable for any incidental or consequential damages for breach of any express or implied warranty on this product, except to the extent prohibited by applicable law. Any implied warranty of merchantability or fitness for a particular purpose on this product is limited in duration to the duration of this limited warranty.
- Used Giles Enterprises, Inc., Foodservice Equipment or parts or Giles Enterprises, Inc., Foodservice Equipment or parts not purchased from an authorized Giles Enterprises, Inc., representative, carry no warranties, express or implied.

Table Of Contents

Model: GGF-400, GGF-720

Safety	vii
Safety Overview	vii
Specific Safety Precautions	viii
1. Introduction	1
1-1. Construction	1
1-2. Standard Features	1
1-3. Optional Features	1
1-4. Specifications	2
1-4.1. Overall Dimensions for GGF-400, GGF-720	2
1-4.2. Regulatory Listings	3
1-4.3. Basket Sizes	3
1-4.4. Cooking Capacity	3
2. Installation	5
2-01. Unpacking	6
2-02. Clearances, Gas Supply, and Electrical Locations	7
2-03. Location	8
2-04. Ventilation	8
2-05. Electrical Requirements	8
2-05.01. Utility Specifications	8
2-06. Electrical Connections	9
2-07. Power Test	10
2-08. Gas Line Connection	10
2-08.01. Typical Gas Line Configuration	11
2-09. Gas Orifice Configuration and Replacement	12
2-10. Gas Pressure Setting and Adjustment	13
2-11. Blower Vacuum Switch Setting and Adjustment	14
2-12. Filter Pump Test	15
2-13. Restraint Device	16
2-14. Perform Boil Out	16
2-15. Clean Fry Basket and Filter Pan	16
3. Overview	17
3-1. Control Panel	18
3-2. Lower Cabinet Area	20
3-3. Filter Pan Assembly	22
3-4. Basket and Elevator Assembly	24
3-5. Accessories (Included)	26
3-6. Accessories (Not Included)	28
4. Unit Preparation	31
4-1. Settings before testing unit	31
4-2. Power test	32
4-3. Operational Check of Burner System	32
4-4. Filter Pump Test	33

4-5.	Perform Boil Out Procedure	33
4-6.	Clean Filter Pan.	33
5.	Fryer Operation	35
5-1.	Cooking Controller	36
5-1.1.	Button and Function	37
5-1.2.	Programming a Cooking Temperature and Time	38
5-1.3.	Enter a cooking cycle	40
5-1.4.	Exit the current cooking cycle	40
5-1.5.	Enter Cool Cycle	41
5-1.6.	Exit Cool Cycle	41
5-1.7.	Lower and raise cooking basket.	41
5-1.8.	Enter Boil out cycle.	42
5-1.9.	Exit Boil out cycle	42
5-2.	Cooking Procedure	43
5-3.	Filtering Liquid Shortening	47
5-4.	Removal of Liquid Shortening	49
5-5.	Normal Shut-Down	52
5-6.	Emergency Shut-Down.	52
6.	Cleaning	53
6-1.	Boil-Out Procedure (Cleaning the Fry Pot)	53
6-2.	Cleaning the Filter Pan and replacing Filter Paper after Boil Out	56
6-3.	Cleaning the Filter Pan and replacing the Filter Paper daily	57
7.	Troubleshooting	59
7-1.	Temperature Control System	59
7-2.	Oil Filtration System	62
7-3.	Basket Elevator System	62
8.	Parts List	63
8-1.	Parts Ordering and Service Information	63
8-2.	Control Panel & Front Header.	64
8-3.	Front Lower Cabinet.	66
8-4.	Rear Lower Cabinet	68
8-5.	Basket Cover and Basket	70
8-6.	Filter Pan.	72
8-7.	Plumbing	74

Table Of Contents

Model: GGF-400, GGF-720





Notes:

Safety

Safety Overview

The instructions contained in this manual have been prepared to aid you in learning the proper procedures for installing and servicing your new unit.

Throughout this manual, safety precautions are identified through the use of the safety alert symbol and three signal words: **DANGER**, **WARNING** and **CAUTION**. All safety alert information precedes the step(s) to which they apply. Suggested, recommended or other noteworthy information is identified through the use of **NOTES**. Additionally, certain words are used to indicate a specific meaning or to add emphasis.

The following words are used as indicated throughout the manual:

Shall: understood to be mandatory.

Should: understood to be advisory.

May: understood to be permissive.

Will: indicates a future event/condition to occur.

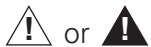

Used in conjunction with signal words (**DANGER**, **WARNING** or **CAUTION**) to alert you of potential personal injury hazards, immediately preceding precautionary measures that pertain to subsequent step(s). Obey all safety messages that follow this symbol to avoid possible injury or death. Failure to adhere to safety precautions identified by the safety alert symbol may also void the warranty.

DANGER

- Indicates an imminently hazardous situation which, if not avoided, will result in death or serious personal injury.

WARNING

- Indicates a potentially hazardous situation which, if not avoided, could result in death or serious personal injury.

CAUTION

- Indicates a potentially hazardous situation which, if not avoided, may result in minor to moderate personal injury. Also used to alert against unsafe practices.

CAUTION

- When used without the safety alert symbol, **CAUTION** indicates a potentially hazardous situation which, if not avoided, may result in equipment or property damage, and void the warranty.

NOTE:

- Identifies suggested, recommended, or other noteworthy information.

Specific Safety Precautions

For your safety, please observe the following precautions when operating or servicing your Giles, Model GGF Gas Fryer. Read the following important safety information to avoid personal injury and/or damage to the equipment.

 **DANGER**

- Place unit's power switch in the OFF position and turn supply power at the facility's circuit breaker panel before cleaning or performing maintenance.
- **DO NOT** wash down the GGF Fryer's interior or exterior with water from a spray hose.
- Failure to comply with these **DANGER** notices will result in death, serious personal injury or equipment and property damage.

 **WARNING**

- Consult a certified electrician to ensure that:
 - all electrical specifications and codes are met.
 - circuit breakers and wiring are of sufficient rating and gauge.
- The GGF Fryer must be properly grounded and all electrical specifications must be met during installation.
- Improper installation, adjustment, alteration, service or maintenance could result in death or serious injury, equipment/property damage, and void the warranty.
- **DO NOT** use or store gasoline, other flammable liquids or materials that generate flammable vapors in the vicinity of this or any other appliance!
- Failure to comply with **WARNING** notices could result in death or serious injury, and equipment/property damage and void the warranty.

 **CAUTION**

- The GGF Fryer, must remain in the upright (vertical) position.
- Exercise care when removing the unit from shipping packaging.
- **DO NOT** operate the GGF Fryer, unless you fully understand the components and their intended function (see Section 3).
- The GGF Fryer, and its parts become very HOT during operations! Temperatures inside the unit's cabinet may exceed 150°F (65.5°C). Exercise caution when operating, loading/unloading food items, cleaning or servicing. Wearing of thermal oven mitts is recommended.
- Failure to comply with **CAUTION** notices may result in minor to moderate personal injury, equipment/property damage, and void the warranty.

CAUTION

- **Fryers must be adequately and properly grounded. Improper grounding may result in electrical shock. Always refer to local electrical code to ensure proper grounding of this or any other electrical equipment. Always consult with a certified electrician or other qualified service technician to ensure breakers and wiring are of sufficient rating and gauge for the equipment being operated.**
- Giles Fryers are available from the factory wired for various voltages, phase and Hz. Check the rating plate inside the front door of the fryer to determine correct supply power required.
- Ensure the fry kettle is positioned in a secure, safe location with casters in the locked position.
- Consult an electrician to ensure all electrical specifications have been met and the unit is properly grounded. The wiring diagram included with this manual should aid electrician in the installation of the fryer.
- Due to the high temperature of shortening during cooking operations, it is extremely important that the user exercise caution when operating this equipment to avoid personal injury.
- Before attempting to operate the unit, refer to Section 3 to familiarize yourself with the various control functions. Once you have read and fully understand Section 3, please follow the steps below precisely in order to prevent equipment damage or malfunction.
- Be careful not to puncture the filter paper when using brushes to unclog the Drain Valve.
- Allow the unit to cool down a minimum of 15 minutes before cleaning or servicing.

CAUTION

- The electronic components of the Control Panel are impact-sensitive. Exercise care around the Control Panel to maintain proper operation.
- **DO NOT** install the unit next to combustible walls and materials. Failure to maintain safe distances may result in fire.
- During cleaning of the GGF Fryer:
 - **DO NOT** steam clean or use water sprayed from a hose.
 - **DO NOT** use products containing chlorine.
 - **DO NOT** use abrasive products, steel wool or scouring pads.
 - **DO NOT** use oven cleaner.
- Failure to comply may violate local health codes.
- **DO NOT** modify, alter or add attachments to this equipment!

NOTE:

- If upon receipt, palletized unit shows any signs of damage, immediately inspect the GGF Fryer and its associated components, and notify the freight carrier of any and all damages.
- To aid the electrician, an electrical wiring diagram is contained in this manual. Refer to the wiring diagram during installation or servicing. A diagram is also attached to the Back Panel of the Fryer.
- Comply with all appropriate state and/or local health regulations regarding cleaning and sanitation of this equipment.

1. Introduction

Congratulations on the purchase of your new Giles equipment, Model GGF-400 or GGF-720 Gas Fryer, manufactured by Giles Enterprises, Inc., Montgomery, Alabama (USA), hereafter referred to as "Giles". Every unit is thoroughly inspected and tested prior to shipment. Proper care and maintenance will ensure years of trouble-free service.

To help protect your investment in this state-of-the-art cooking equipment, we recommend you take a few moments to familiarize yourself with the installation, cleaning and maintenance procedures contained in this manual. Adherence to these recommended procedures minimizes the potential for costly "Down-Time" and equipment repairs. Please retain this manual for future reference.

1-1. Construction

Model GGF-400 & GGF-720, is constructed of stainless steel.

1-2. Standard Features

Programmable Controller - Used to control the temperature of the cooking oil and the amount of cooking time. There are 8 separate programmable menu keys.
"Low Oil " and "Drain Open" warning messages.
Pre-programmed Boil-Out program & Cool Mode function.

Dual Burner system - Special dual burner system on the GGF-720 delivers maximum BTU's when needed, while saving gas during light load cooking and idle periods.

Automatic Basket Lift - Automatically lowers product when menu program is selected and lifts basket from hot oil at the conclusion of the cooking cycle.

Oil Filtration System - Completely self-contained and extends the life of cooking oil. Designed to perform a complete filter cycle within five minutes.

1-3. Optional Features

1-4. Specifications

1-4.1. Overall Cabinet Dimensions for GGF-400, GGF-560, GGF-720

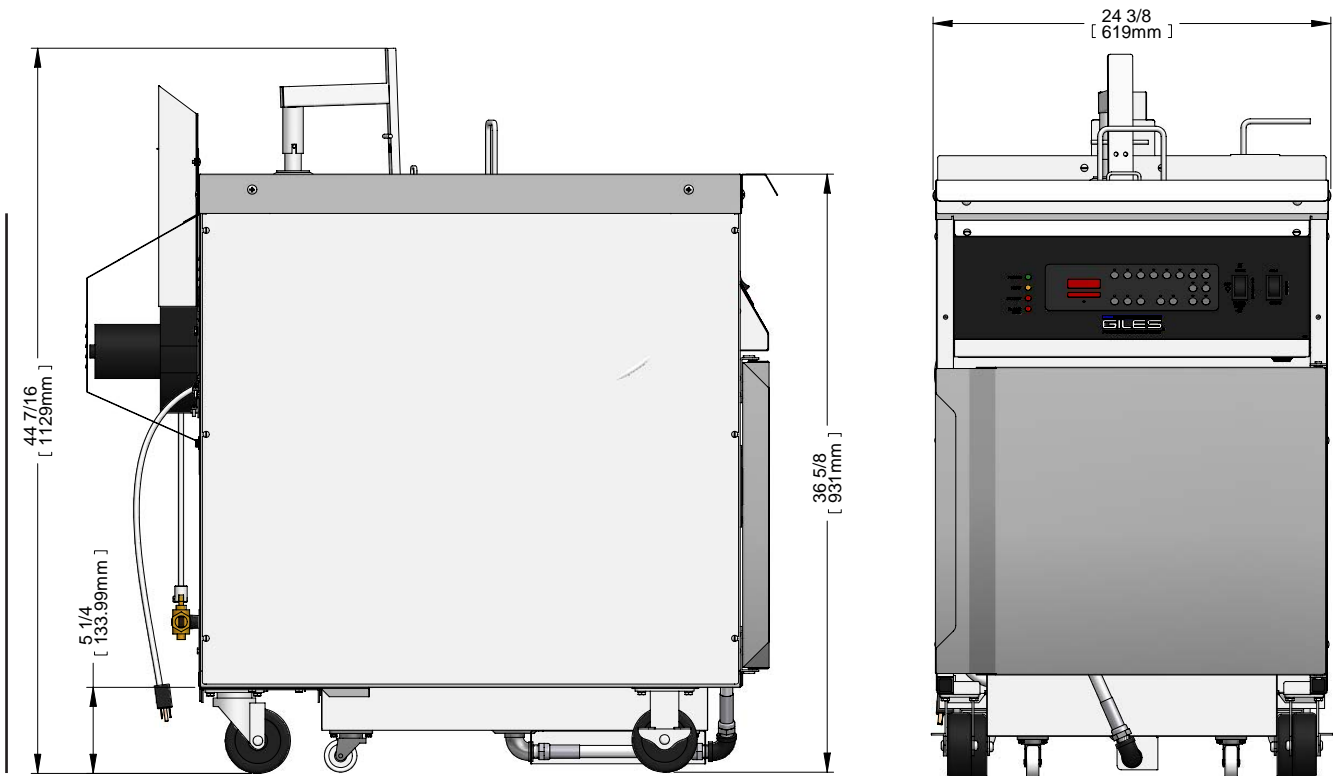
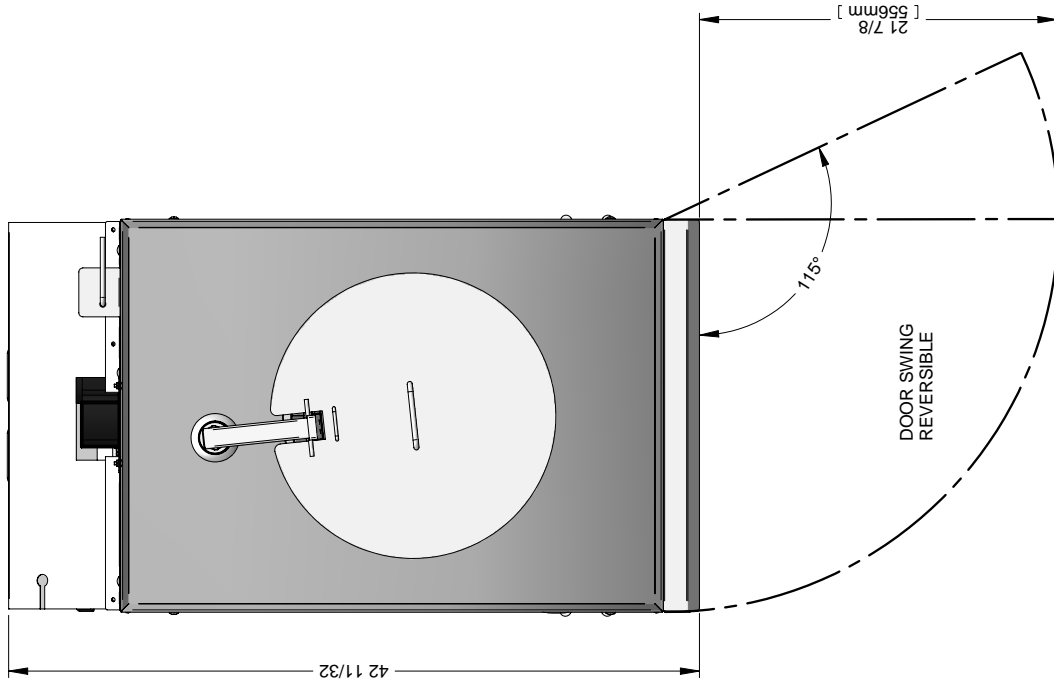

1-4.2. Regulatory Listings



1-4.3. Basket Sizes

Model	Basket Size (useable inside dim.)				Volume	
	Diameter		Height		cu. inch	cu. meter
	in	mm	in	mm		
GGF-400	12.37	314.19	10.25	260.35	1231.83	0.0201
GGF-720	14.50	368.30	13.03	331.35	2151.65	0.0353

1-4.4. Cooking Capacity

Model	Liquid Shortening Capacity **				Chicken Capacity		
	lb	kg	gallon	liter	lb	kg	piece count*
GGF-400	45	21	5.8	21.9	14	6.3	40
GGF-720	75	34	9.7	36.7	24	10.8	72

** Never exceed max. fill line on fryer.

* Avg. 2-3/4 lb. chicken



- Exceeding product (chicken) capacity or over-filling vat with shortening may cause personal injury and/or equipment/property damage.



2. Installation

This section provides a summary of the procedures necessary for proper installation of your new Giles equipment, Model GGF Gas Fryer. To prevent personal injury or equipment damage, please ensure the following steps are taken and the following check sheet is initialed and dated.

CAUTION

- Various installation steps MUST be performed only by a Licensed Electrician.
- Various installation steps MUST be performed only by a Qualified Gas Technician.

NOTE:

- When installed, appliance must be electrically grounded in accordance with the local codes, or in the absence of local codes, with the *National Electrical Code, ANSI/NFPA 70*, or the *Canadian Electrical code, CSA C22.2*, as applicable.

INSTALLATION CHECK SHEET

Check	Date	Initial	Section	Description
X	8/18/05	CSY	0.0	Completely read Manual (EXAMPLE)
			2-01.	Inspect crate for damage
			2-01.	Uncrate
			2-02.	Proper clearances
			2-04.	Proper ventilation
			2-05.	Proper circuit breaker installed (Licensed Electrician Only)
			2-06.	Proper electrical connections (Licensed Electrician Only)
			2-07.	Unit has power (Licensed Electrician Only)
			2-08.	Gas line connected (Qualified Gas Technician Only)
			2-09.	Correct gas orifice installed (Qualified Gas Technician Only)
			2-10.	Correct gas pressure setting (Qualified Gas Technician Only)
			2-11.	Correct blower vacuum switch setting (Qualified Gas Technician Only)
			2-12.	Filter Pump operating
			2-13.	Restraint device installed
			2-14.	Performed Boil-Out procedure
			2-15.	Cleaned Filter Pan

2-01. Unpacking

The Fryer should arrive palletized on a wooden skid, secured with high-tensile plastic strapping and wrapped by machine applied stretch wrap.

CAUTION

- The Fryer must remain in the upright (vertical) position.
- Exercise care when lifting or moving the unit.
- Exercise care when removing the wooden crate from around the unit.
- Failure to comply with these **CAUTION** notices may result in minor or moderate injury, equipment/property damage, and void the warranty.

NOTE:

- If when received, the palletized unit exhibits any signs of damaged, immediately inspect the Fryer and associated items, and notify the freight carrier of damages.

1. Carefully cut and remove the plastic shipping wrap and the strapping.
2. Remove and properly dispose of shipping materials.
3. Carefully remove the Fryer from the shipping pallet. The GGF Fryer is very heavy, weighing approximately 280 lbs (127 kg) uncrated. Extreme care should be taken when lifting or moving the unit to prevent personal injury and/or equipment damage.

2-02. Clearances, Gas Supply and Electrical Locations

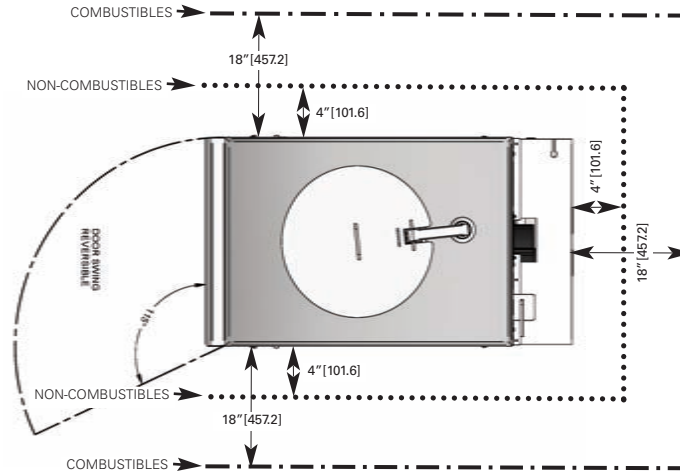

PLUG CONFIGURATION
NEMA 5-15P
120V ONLY

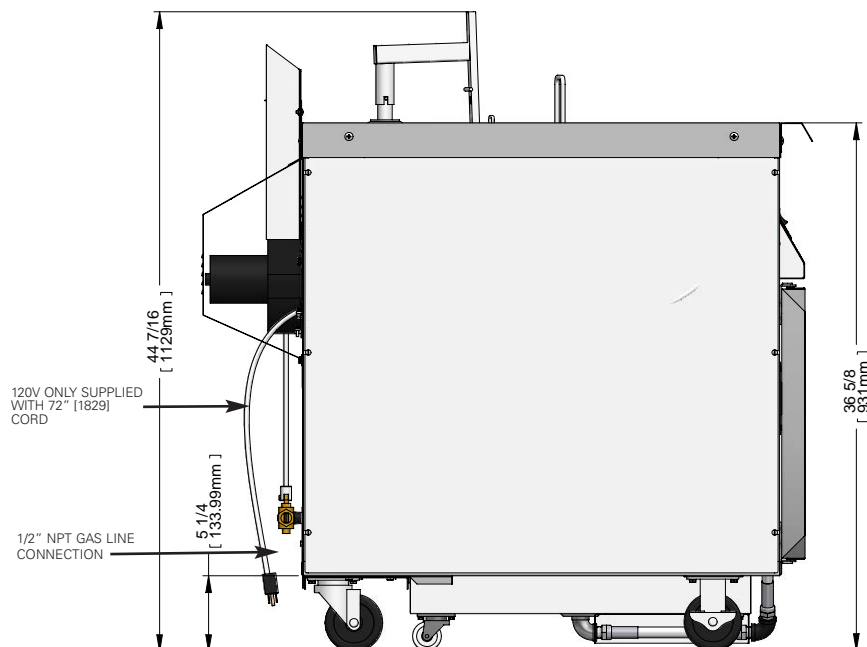
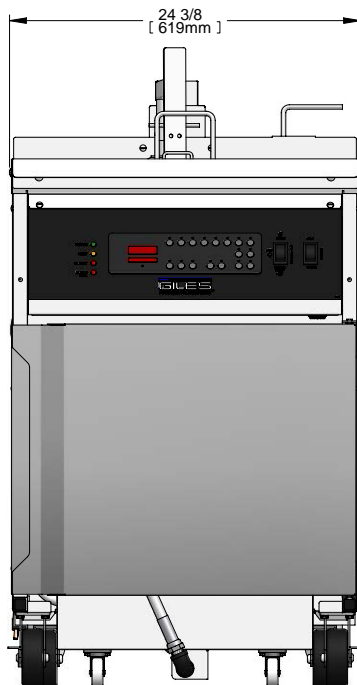

INCHES [mm]

2-03. Location

CAUTION

- **DO NOT MODIFY, ALTER OR ADD ATTACHMENTS TO THIS EQUIPMENT**

1. Keep the appliance and surrounding area free and clear of combustible materials. See illustration 2-02; Clearance, Gas Supply and Electrical Locations.
2. Make sure this unit is secured in position and will not move. See 2-13; Restraining Device.

2-04. Ventilation

NOTE:

- Guidelines for proper ventilation system requirements may differ by locale. Always consult with local authorities to ensure compliance.

This appliance is to be installed, used and maintained in accordance with the Standard for Ventilation Control & Fire Protection of Commercial Cooking Operations, NFPA 96-1994.

Consult a professional, certified, HVAC company for assistance in designing a ventilation hood system for this unit.

2-05. Electrical Requirements

⚠ CAUTION

- **Fryers must be adequately and properly grounded. Improper grounding may result in electrical shock. Always refer to your local electrical code to ensure proper grounding of this or any other electrical equipment. Always consult with an electrician or other qualified service person to ensure breakers and wiring are of sufficient rating and gauge for the equipment being operated.**
- Giles Gas Fryers are available from the factory in the voltage and phase listed below. Check the rating plate on the inside of the fryer’s front door to determine the correct power supply.

Table 2-05.01. Utility Specifications

Model	Voltage	Hz	Phase	AMPS	Breaker Required	Gas Specifications
GGF-400	120	60	1	7.0	15	This equipment requires a 1/2" gas line w/in-line regulator (not supplied). Input gas pressure must be regulated at: 5" - 9" w.c. Natural 13" - 16" w.c. LP
GGF-400	208-230	60	1	4.0	10	
GGF-720	120	60	1	7.0	15	
GGF-720	208-230	60	1	4.0	10	

2-06. Electrical Connections

All Fryers

1. Connect Fryer power plug to an appropriate receptacle which is protected by a properly sized circuit breaker, See Table 2-05.01.



NOTE:

- When installed, appliance must be electrically grounded in accordance with the local code, or in the absence of local code, with the *National Electrical Code, ANSI/NFPA 70*, or the *Canadian Electrical code, CSA C22.2*, as applicable.

2-07. Power test

The following test will ensure the unit has power.

1. Verify that the main circuit breaker supplying power to the unit is ON.
2. Ensure the Selector Switch is in the center OFF **1** position.
3. Place the Power Switch in the ON **2** position. The green POWER light **3** should turn on and the Controller display should illuminate; after a few seconds the display should read **"Hold"**.

If one, or both, of these conditions is not present, refer to the Trouble-shooting Procedures in Section 6-01.
4. Place the Power Switch in the OFF **4** position.
5. Proceed to 2-08; Gas Line Connection.



2-08. Gas Line Connection

CAUTION

- The flue gases of this appliance must be vented to the outside in accordance with National Fuel Gas Code, ANSI Z223.1-1988 and terminate in a UL listed outside vent terminal. When in Canada reference CANI-B149.1 or .2 "Installation Codes for Gas Burning Appliances and Equipment", and the quick disconnect device complies with the Standard for Quick-Disconnect Devices for Use with Gas Fuel, ANSI Z21.41-1989, (in Canada CANI 6.9 M79).
- Ensure the Gas Connector and Line complies with Standard for Movable Gas Appliance, ANSI, 69-1987 and Addenda Z21.69-1989 (in Canada CANI-6-10-88).
- This unit **MUST** be installed with an In-line Regulator (Supplied by Customer).
- This unit **MUST** only be installed by a Qualified Gas Technician.
- Ensure both the Facility Shut-Off Valve and the Fryer's Shut-Off Valve are in the OFF position.

1. After the facility Shut-Off Valve and Quick Disconnect have been installed, connect a 1/2" flexible gas line to the 1/2" Fryer shut-off valve located in the rear of the unit. See 2-08.01; Typical Gas Line Configuration. **Note:** The flexible gas line should be long enough to allow the Fryer to be moved away from wall for servicing and cleaning.

2-08.01 Typical Gas Line Configuration

NOTE:

- **Installation must conform with local codes, or in the absence of local codes, with the National Fuel Gas Code, ANSI Z223.1/NFPA 54, or the Natural Gas and Propane Installation Code, CSA B149.1, as applicable, including:**
 - 1 The appliance must be disconnected from the incoming gas supply line, at the shut-off valve, during any testing of the piping at test pressures in excess of 1/2 psi (3.5kPa)
 - 2 The appliance must be isolated from the incoming gas supply line, by closing the fryer's manual shutoff valve, during any testing of the piping at test pressures equal to or less than 1/2 psi (3.5kPa)

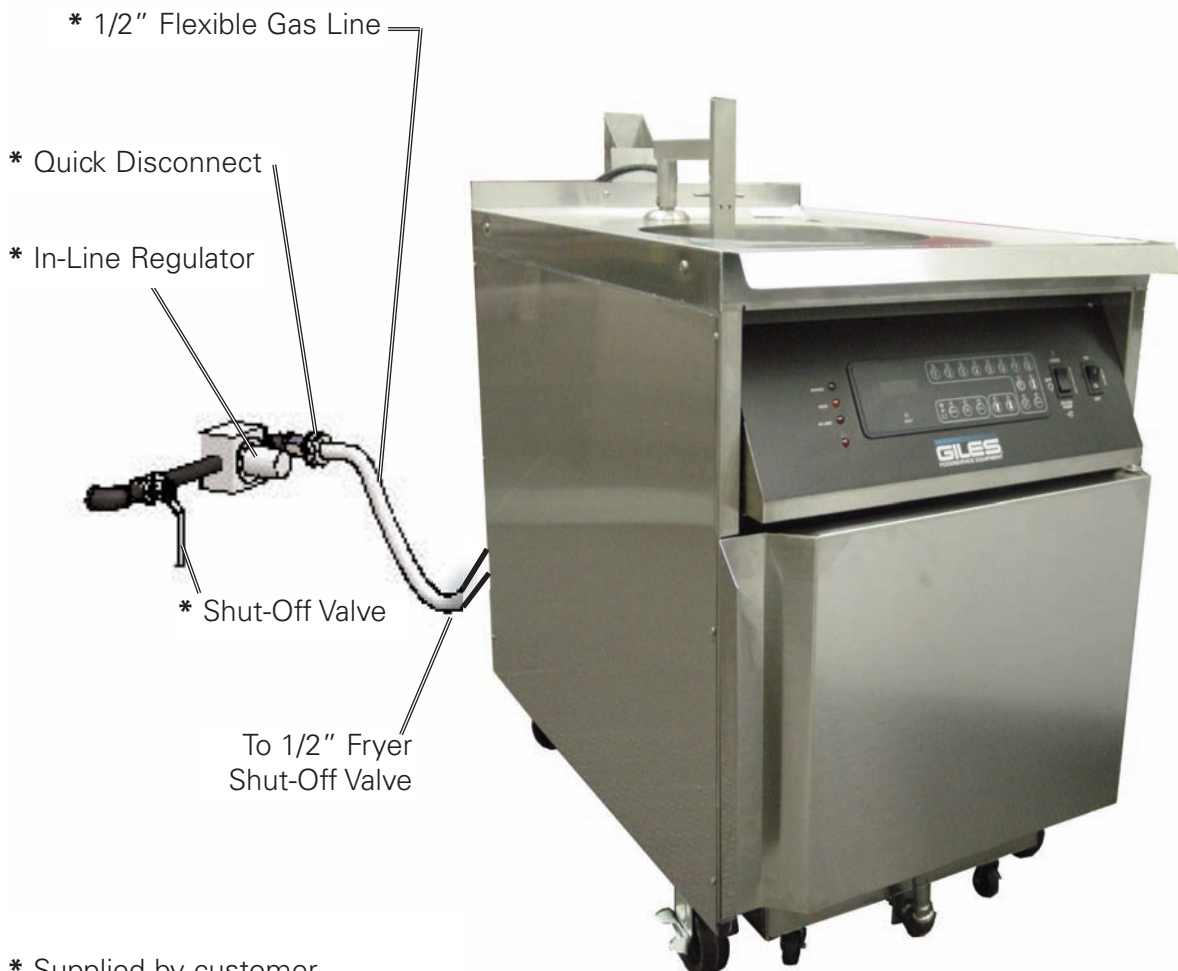

* Supplied by customer.

2-09. Gas Orifice Configuration and Replacement

NOTE:

- This unit is shipped with factory installed gas Orifice(s) suited for 0 to 3,000 feet above sea level - Natural Gas or 0 to 4,000 feet above sea level - LP Gas.

Gas flow varies at different elevations. Verify the elevation of the installation location. If the elevation is greater than noted above, the gas orifice(s) must be changed. Follow the following steps to exchange orifice(s), or if desired, to confirm that proper orifices are installed.

CAUTION

- If changing Gas Types always consult factory for proper Conversion Kit.

1. Ensure power to the unit is disconnected.
2. Confirm that gas valves are in the OFF position.
3. Remove the Fan Guard & Back Panel.
4. It should be possible to examine the stampings on orifice(s) without removing parts. Check information stamped into Orifice.
5. If the Orifice(s) is/are incorrect for the installation altitude, disconnect Gas Line(s) at the Manifold fitting(s).
6. Remove Manifold(s) from Bracket. Remove & replace Orifice(s) with the correct part. See charts below.
7. Re-install Gas Manifold(s) with orifice(s), reconnect gas line(s), and replace Panel & Guard. Proceed to 2-10; Gas Pressure Setting and Adjustment..

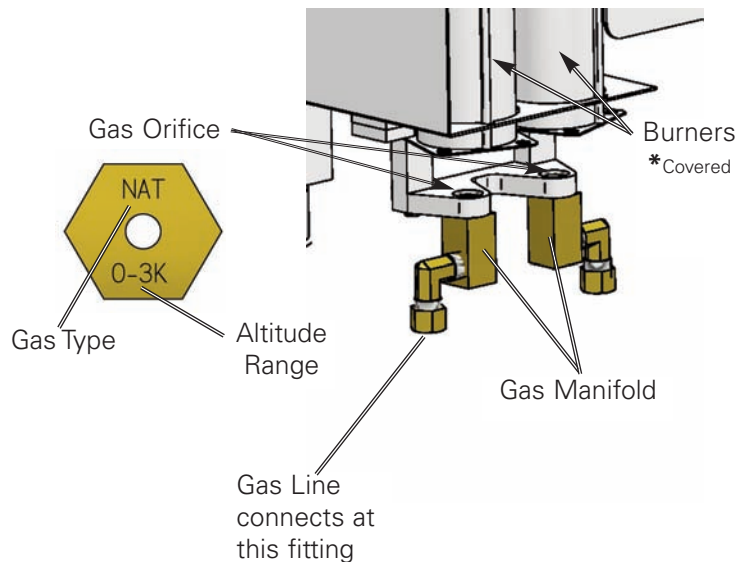

NATURAL GAS				PROPANE			
ALTITUDE IN FEET	INPUT RATING	DRILL SIZE #	ORF P/N	ALTITUDE IN FEET	INPUT RATING	DRILL SIZE #	ORF P/N
0- 999	45000	30(.1285)	46719	0- 999	45000	48(.076)	46723
1000-1999	45000	30(.1285)	46719	1000-1999	45000	48(.076)	46723
2000-2999	43200	30(.1285)	46719	2000-2999	43200	48(.076)	46723
3000-3999	41500	31(.120)	46720	3000-3999	41500	48(.076)	46723
4000-4999	39800	31(.120)	46720	4000-4999	39800	49(.073)	46724
5000-5999	38200	31(.120)	46720	5000-5999	38200	49(.073)	46724
6000-6999	36700	31(.120)	46720	6000-6999	36700	49(.073)	46724
7000-7999	35200	32(.116)	46721	7000-7999	35200	50(.070)	46726
8000-8999	33800	32(.116)	46721	8000-8999	33800	50(.070)	46726

Orifice chart for GGF-400 fryers.

NATURAL GAS				PROPANE			
ALTITUDE IN FEET	*INPUT RATING	DRILL SIZE #	ORF P/N	ALTITUDE IN FEET	*INPUT RATING	DRILL SIZE #	ORF P/N
0- 999	85000	30(.1285)	46719	0- 999	85000	48(.076)	46723
1000-1999	85000	30(.1285)	46719	1000-1999	85000	48(.076)	46723
2000-2999	81600	30(.1285)	46719	2000-2999	81600	48(.076)	46723
3000-3999	78300	31(.120)	46720	3000-3999	78300	48(.076)	46723
4000-4999	75200	31(.120)	46720	4000-4999	75200	49(.073)	46724
5000-5999	72200	31(.120)	46720	5000-5999	72200	49(.073)	46724
6000-6999	69300	31(.120)	46720	6000-6999	69300	49(.073)	46724
7000-7999	66500	32(.116)	46721	7000-7999	66500	50(.070)	46726
8000-8999	63900	32(.116)	46721	8000-8999	63900	50(.070)	46726

Orifice chart for GGF-720 fryers.

2-10. Gas Pressure Setting and Adjustment

Use the following procedure to set the Fryer manifold pressure to correct setting. This ensures that the BTU input of burner(s) is at the proper level.

1. Fill the Fry Pot with water to the FULL line.

CAUTION

- NEVER check or adjust the gas pressure without the Fry Pot filled with water.

2. Remove the Gas Valve Access Panel (lower left corner, back of Fryer).
3. Remove the Pressure Tap Plug from the Gas Valve.
4. Remove the Pressure Adjustment Cover Plug on the Gas Valve.
5. Connect a digital manometer to the Gas Valve Pressure Tap.
6. Place the Gas Shut-Off Valve in the OPEN position.
7. Place the Power Switch in the ON position and the Selector Switch in the COOK position.
8. The burner(s) should ignite and the unit will begin heating.
9. Using a screwdriver, adjust the Gas Valve Pressure to the following:

GAS TYPE	WATER COLUMN
NATURAL	4 in.
LP	11 in.

10. Place the Power Switch in the OFF position and the Selector Switch in the OFF position.
11. Remove the manometer and replace the Pressure Tap Plug.
12. Replace the adjustment screw cover plug.
13. Replace the Gas Valve Access Panel.
14. Proceed to 2-11; Blower Vacuum Switch Setting, or drain water from the fry pot into a suitable container.

* Not supplied with unit

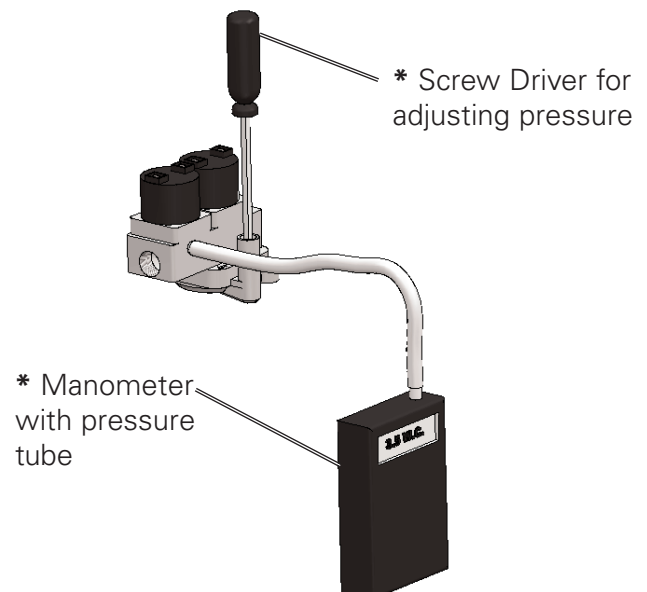
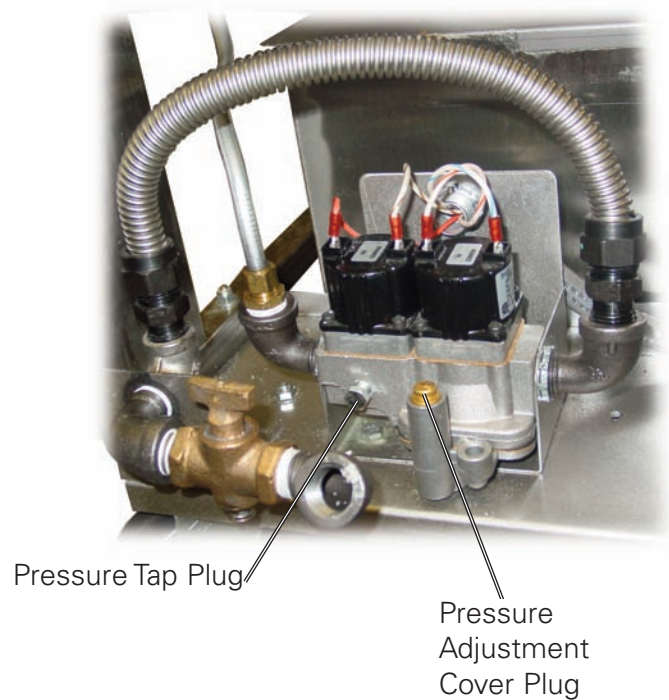

2-11. Blower Vacuum Switch Setting and Adjustment

The Blower Vacuum Switch ensures that the unit has the proper draft air-flow before allowing the gas valve to open for ignition. Ensure the Blower Vacuum Switch is set to the proper setting by using the following steps.

1. Fill the Fry Pot with water to the FULL line.

CAUTION

• NEVER check or adjust the Blower Vacuum Switch without having fry pot filled with water, or oil.

2. Place the Power Switch in the ON position, the Power Light will illuminate.
3. Place the Selector Switch in the COOK position; Heat Light will illuminate and burner(s) will light.

CAUTION

• During the next step use great caution and wear oven mitts, due to the extremely hot temperature of air being exhausted from the flue stack.

4. Using a non-combustible material, such as a piece of metal, cover about half of the exhaust stack opening diagonally from corner to corner.
5. The Heat Light should turn off & the burner(s) should shutdown. When the opening is unblocked, the fryer should re-light. Proceed to step 10.

If the burner(s) fails to shutdown, the Blower Vacuum Switch must be adjusted as follows.

6. Turn off power & close the gas valve.
7. Remove screws and lower the front Control Panel.
8. Locate pressure switch on left side of the control box.
9. Slowly rotate the pressure switch adjustment dial - clockwise increases sensitivity, counter-clockwise decreases. Repeat steps 2 - 5. Continue adjustments until the burner(s) shutdown when approx. half the flue stack opening is blocked.
10. Proceed to 2-12. Filter Pump Test or Drain Water from the Fry Pot to a suitable container.

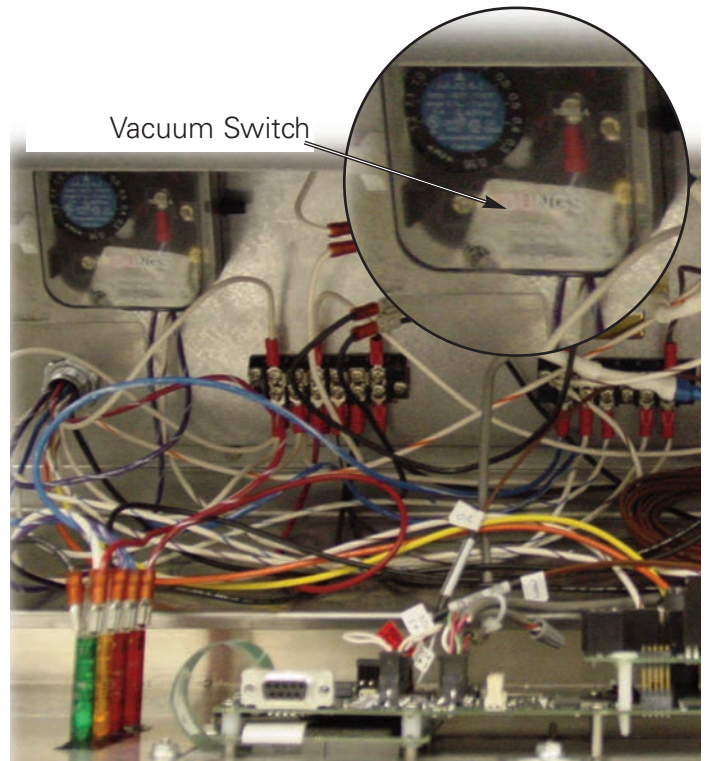

2-12. Filter Pump Test

The following test will ensure the Filter Pump is operating correctly.

CAUTION

- Before proceeding with this test, ensure the unit has thoroughly cooled. Contact with **HOT** parts is possible if not thoroughly cooled.

1. Open the Cabinet Door, disconnect the Filter Pan quick-disconnect from the unit and remove the Filter Pan.
2. Place the Power Switch in the ON **1** position.
3. Place the palm of your hand over the Filter Pan quick-disconnect opening.
4. Briefly place the Selector Switch to the PUMP **2** position and then return it to the OFF **3** position. If suction is felt against the palm, the pump is operating correctly. Proceed to Section 2-13; Restraint Device.

If no suction is felt, refer to the Troubleshooting procedures in Section 6-02.

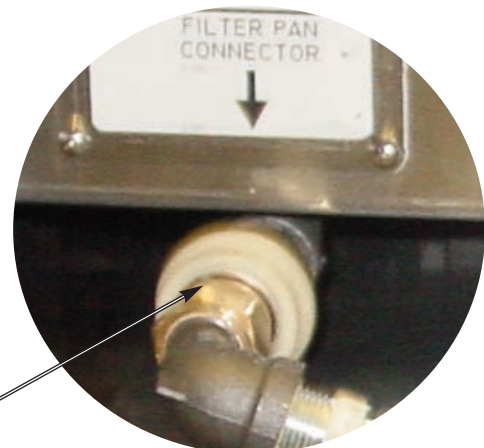

With Filter Pan removed, place hand over quick-disconnect opening.

2-13. Restraint Device

This unit requires use of some type Restraint Device (not included with the unit) to prevent the unit from being unintentionally moved and to prevent strain on electrical and gas line connections. The Restraint Cable length must be shorter than both electrical cord, or conduit, and the flexible gas line. A restraint anchor must be fastened to a non-movable wall. Use a quick disconnect latch on one end of the Restraint Cable so the cable can be removed during servicing. After installation of the Restraint Device proceed to 2-1; Perform Boil-Out Procedure.

* Restraint Anchor attached to non-movable wall

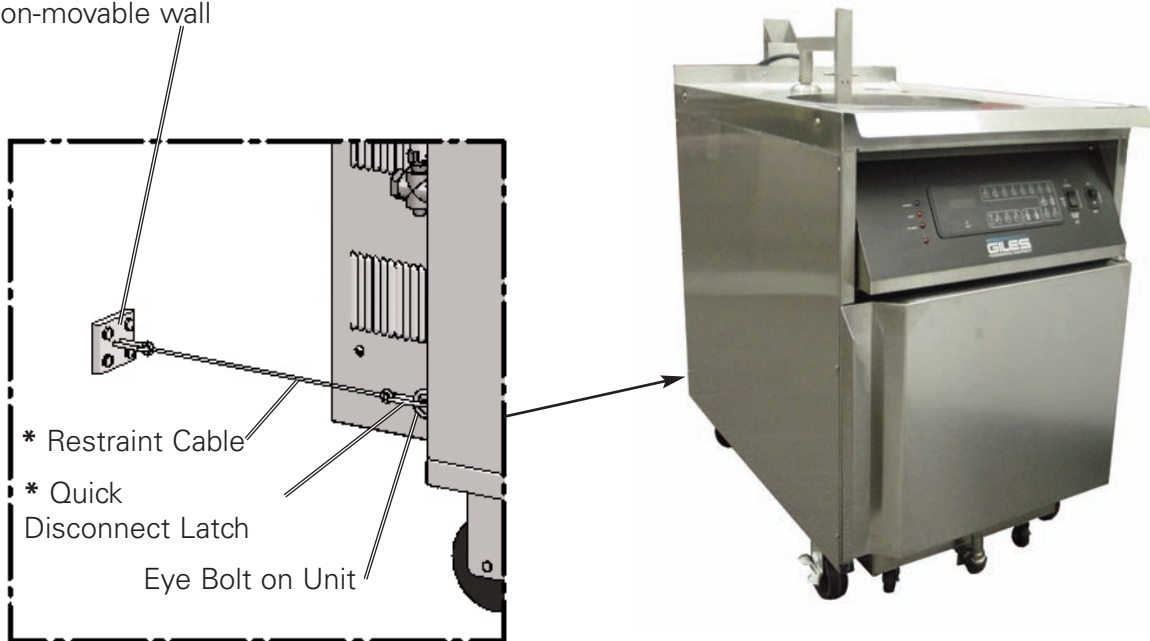

* Supplied by customer.

2-14. Perform Boil-Out Procedure

Perform a Boil-out Procedure to remove any dust, dirt or debris that may have accumulated in the pot during shipping. Follow Section 5-01; Boil-Out Procedure. After performing the Boil Out Procedure proceed to Section 2-15; Clean Fry Basket and Filter Pan.

2-15. Clean Fry Basket and Filter Pan

Thoroughly clean the Fry Basket and the Filter Pan to remove any dust, dirt, oils or debris that may have accumulated during shipping or manufacturing. Follow Section 5-02; Cleaning the Filter Pan and replacing Filter Paper after Boil-Out.

Fryer installation is now complete. Please proceed to the Overview Section.

3. Overview

The following section provides a brief overview of the components, functions and accessories associated with the Giles Model GGF-400 & GGF-720 Gas Fryer. Please review this section carefully before proceeding any further.



3-1. Control Panel



3-1. Control Panel

Item	Description	Function
1	Power Switch	The Power Switch is a 2-position Switch. Move the switch upward to the "ON" position for operation.
2	Selector Switch	The Selector Switch is a 3-position switch which is used to select either "COOK," "OFF" or "FILTER" mode of operation. The fryer's heating system will only operate in the "COOK" position. The switch should be placed in the "FILTER" position only to operate the pump for filtering or removal of old shortening for disposal.
3	Controller	The electronic Controller is used to set cooking temperatures and times. It controls the cooking cycle & displays alarm conditions.
4	High-Limit Indicator	The Red High-Limit Indicator Light illuminates to signal an overheat condition and that the solid-state safety circuit has disabled the fryer's burner(s). Should this light come on during operation, refer to the Troubleshooting Section 7 of this manual. NEVER ATTEMPT TO COOK IN A FRYER WHEN THE HIGH-LIMIT LIGHT IS ON!
5	Heat Indicator Light	The Orange Heat Indicator Light will be on when the fryer's heating system is operating (burner ignited). The light will be ON & OFF intermittently during cooking as setpoint temperature is being maintained by the Controller.
6	Power Indicator Light	The Green Power Light is on whenever the fryer's Master Power Switch is in the ON position.
7	Flame Fail Indicator	The Red "Flame Fail" Indicator Light turns on when the burner control module detects there is no flame at the burner.

3-2. Lower Cabinet Area

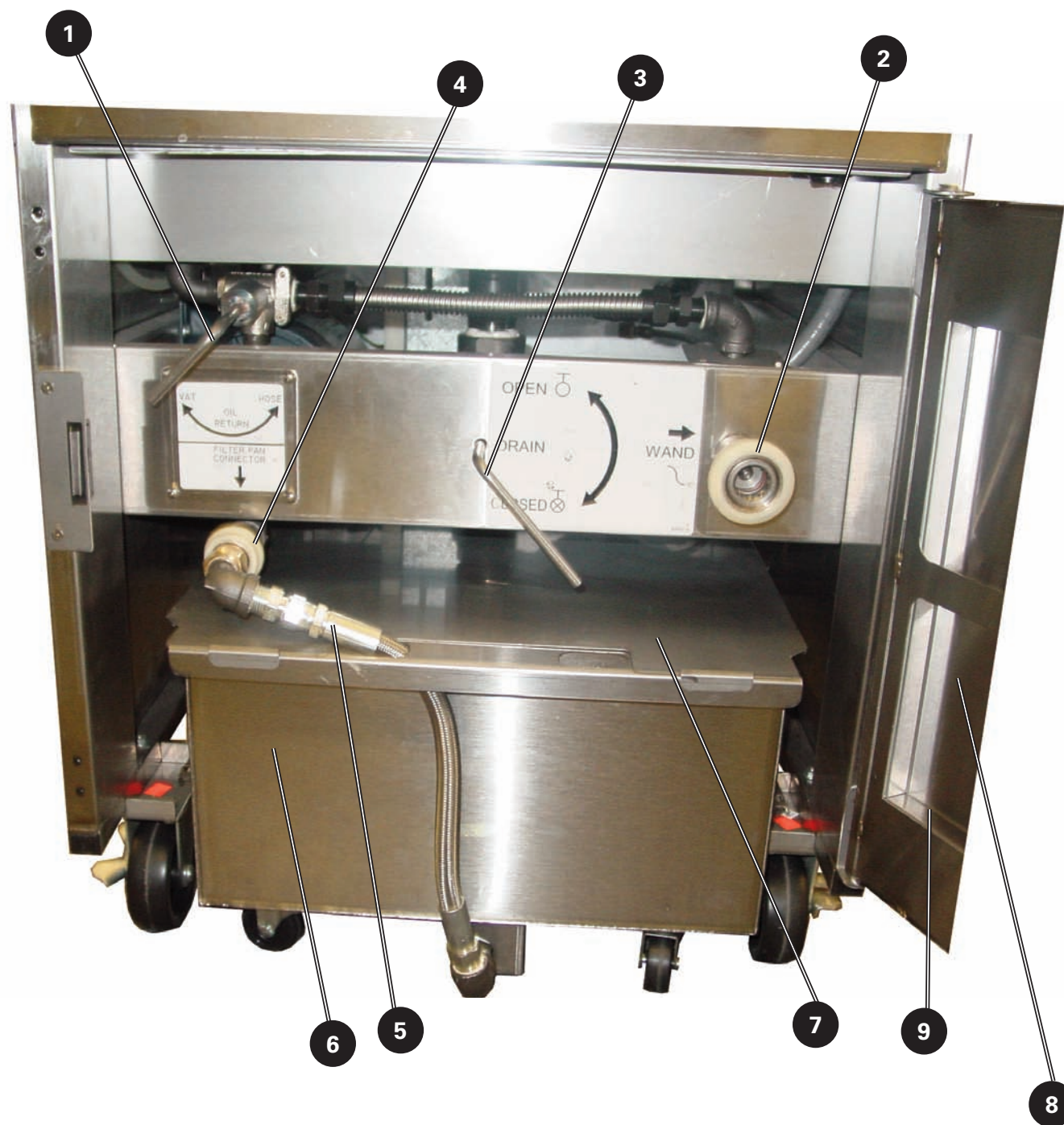

3-2. Lower Cabinet Area

Item	Description	Function
1	Diverter Valve Handle	Used to direct cooking oil flow when the pump is in operation, either to the cook vat or to the oil discharge hose.
2	Quick Disconnect for Oil Discharge Hose	Used to connect the Oil Discharge Hose to the Fryer for removal of used cooking oil.
3	Drain Valve Handle	Used for opening the cook vat drain. Always ensure the valve is closed prior to adding cooking oil or boil out solution. The Fryer will not heat if this drain valve is not completely closed.
4	Quick Disconnect for Filter Pan Hose	Used to connect the Filter Pan hose to the Fryer oil filtration system.
5	Filter Pan Quick Disconnect Hose	See Section 3-3.
6	Filter Pan	See Section 3-3.
7	Filter Pan Cover	Protects cooking oil from foreign material contamination while it is temporarily being contained in the Filter Pan.
8	Operation Manual Holder	Door pocket serves as a convenient place to store the Operation Manual.
9	Cabinet Door	Access for all lower cabinet functions. Cabinet Door is field reversible, if needed or desired.

3-3. Filter Pan Assembly

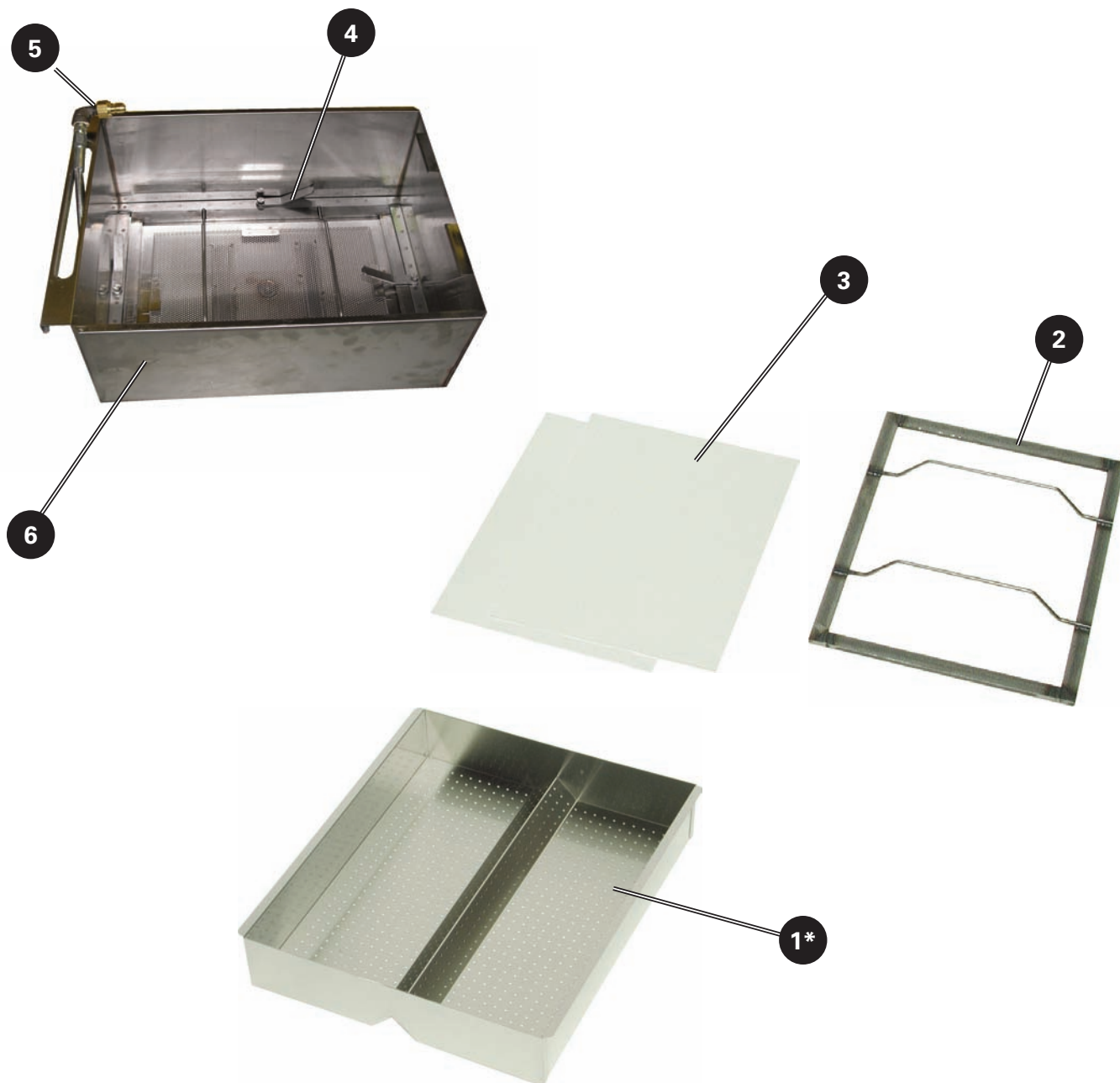

* Not standard item ... ordered separately

3-3. Filter Pan Assembly

Item	Description	Function
1*	Crumb Screen	Designed to capture and filter larger particles of cooking sediment and residue from the cooking oil as it drains into the Filter Pan.
2	Hold Down Frame	Used to tightly hold down the filter paper. Improper placement will likely affect filter pump performance.
3	Filter Paper	Used to filter finer particles of sediment and residue from the cooking oil.
4	Hold Down Levers (4)	Used to hold the Hold-Down Frame firmly against the Filter Paper. Improper placement will likely affect filter pump performance.
5	Filter Pan Quick-Disconnect Hose	Connects the Filter Pan to the Fryer's oil filtration system. The hose must be disconnected for Filter Pan removal.
6	Filter Pan	Contains and filters cooking oil during the filter cycle. The Filter Pan is removable for cleaning and changing of the filter paper. Pan features a permanently attached perforated filter paper support screen, which will prevent introduction of large particulate into the filter system should paper be accidentally torn. THIS IS NOT A FILTER!

* Not standard item ... ordered separately

3-4. Basket and Elevator Assembly

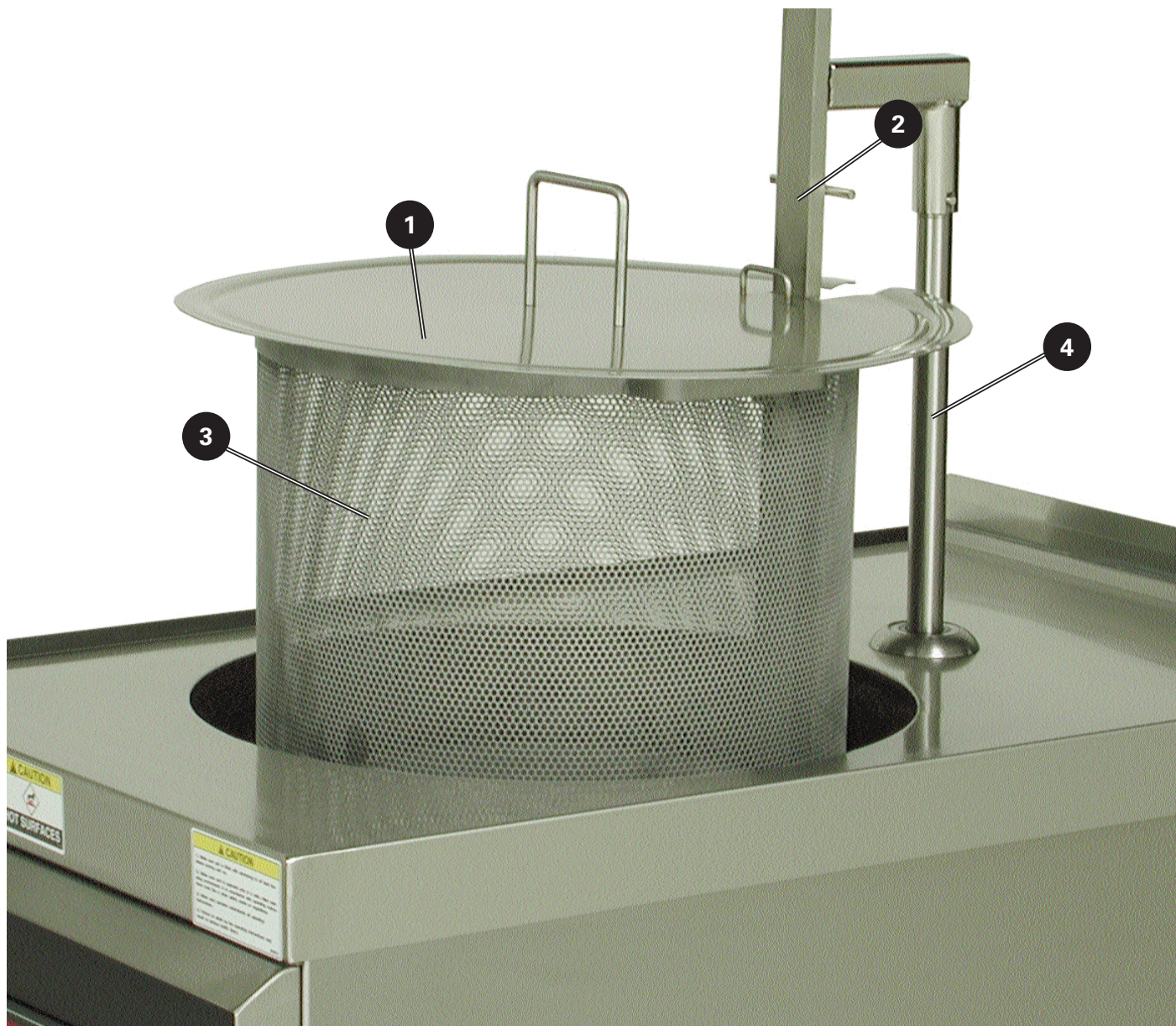





3-4. Basket and Elevator Assembly



Item	Description	Function
1	Basket Cover	Covers cook vat during the cooking cycle. When in place prevents hot cooking oil from splashing out of the vat.
2	Basket Carrier	Holds Fry Basket as it is lifted or lower by the Auto-Basket Lift.
3	Basket	Holds product for cooking.
4	Auto-Basket Lift	Lowers and lifts Fry Basket into and out of the cooking vat.



3-5. Accessories (Included)

Part	Description/ Part Number	Function
	<p>Kettle Drain Brush P/N 71025</p>	<p>Use to clean the Fry Pot & pot Drain.</p>
	<p>Stir Paddle P/N 77775</p>	<p>Use to stir cooking oil and products being cooked.</p>
	<p>Pot Brush P/N 71100</p>	<p>Use to clean Fry Pot.</p>
	<p>Crumb Shovel P/N 30059</p>	<p>Use to remove filter sediment from Filter Pan.</p>

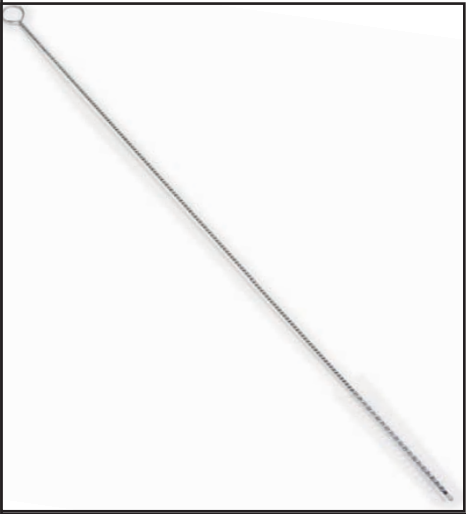
3-5. Accessories (Included)

Part	Description/Part Number	Function
	<p>Small Teflon Brush, P/N 73235</p>	<p>Use to clean space between heat exchanger and pot wall.</p>
	<p>Discharge Hose Assembly P/N 33667</p>	<p>Use for removing liquid shortening from unit.</p> <p>NOTE: DO NOT USE TO WASH DOWN THE COOK VAT!</p>
	<p>L-Shaped Teflon Brush P/N 73233</p> <p>NOTE: No longer provided; needed only for older model GGF-720's (pre-Nov 2009). Replaced by P/N 73253 above.</p>	<p>Use to clean space between heat exchanger and pot wall.</p>

3-6. Accessories (Not Included)

Part	Description/ Part Number	Function
	<p>Filter Paper P/N 60810</p>	<p>Use to filter the cooking oil.</p>
	<p>Filter Powder P/N 72004</p>	<p>Use as an aid in filtering cooking oil.</p>
	<p>Fryer Boil-Out P/N 72003</p>	<p>Fry pot cleaning agent, add to water during boil-out procedure.</p>

3-6. Accessories (Not Included)

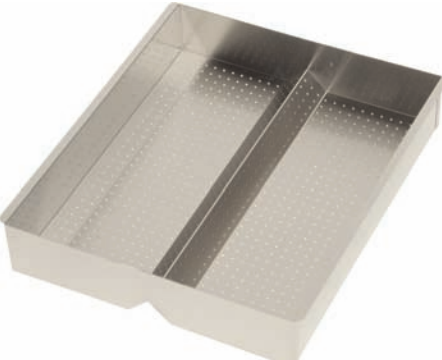
Part	Description/ Part Number	Function
 <p>A stainless steel oil disposal container with a pump handle, hose, and spout. The front panel features the Giles logo and technical specifications.</p>	<p>Giles Oil Caddy P/N 79187</p>	<p>A portable oil disposal container with a capacity of 80-lbs of liquid shortening.</p> <p>Note: For use with filtered, warm oil only. No crumbs or debris.</p>
 <p>A rectangular stainless steel tray with a perforated bottom and a central divider.</p>	<p>Filter Pan Crumb Screen P/N 39246</p>	<p>Helps prevent larger crumb particles or cooking debris from getting into or clogging the filter system.</p>



Notes:

4. Unit Preparation

Giles Enterprises, Inc. takes pride in the quality of its workmanship. Every effort has been made to ensure that you have received a unit that is in excellent operating condition. Each unit must pass rigorous quality control tests prior to shipment. To further ensure optimum performance of your new unit, we recommend that a brief operational check-out be completed before putting the fryer into service.

Before attempting to operate the unit, refer to Section 3 to familiarize yourself with the various control functions. Once you have read and fully understand Section 3, please follow the steps below precisely in order to prevent equipment damage or malfunction.

4-1. Settings before testing unit

Please ensure the unit is set to the following settings before proceeding.

1. Power Switch is in the OFF **1** position.
2. Selector Switch is in the center, **2** OFF position
3. Open the Cabinet Door and remove the Filter Pan **3**.
4. Ensure the Drain Valve Handle is in the CLOSED **4** "down" position.
5. Ensure the Oil Diverter Valve is in the VAT "left" **5** position.
6. Remove Basket Cover, Basket Carrier, and Basket.

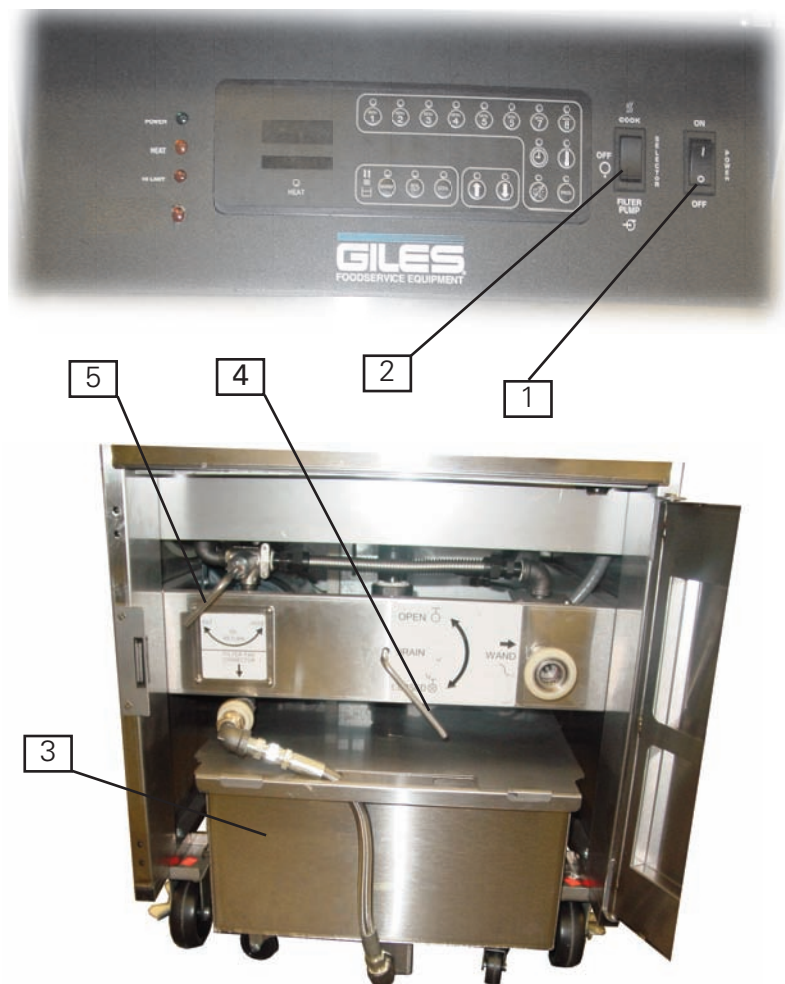

4-2. Power Test

The following test will ensure the unit has power.

1. Follow steps shown in Section 4-1.
2. Ensure the main circuit breaker powering the unit is ON.
3. Place the Power Switch in the ON 1 position. The green POWER light 2 will come on. Proceed to Section 4-3.

If the POWER does not come on, refer to the Troubleshooting procedures in Section 8-1.



4-3. Operational Check of Burner System

This step will confirm that the fryer's Heat Exchanger is functioning properly.

WARNING

DO NOT touch the Heat Exchanger during this check. The Heat Exchanger gets very hot and contact with it may result in severe burns.

CAUTION

This portion of the check requires that the Burner System be activated. DO NOT allow the burner(s) to remain on for more than 10 seconds without Heat Exchanger being fully covered by shortening or water. Failure to observe this precaution may result in damage to the Heat Exchanger and Burner System.

1. With the Heat Exchanger cool and dry, wipe it down with a soaked wet sponge; enough so that it remains wet.
2. With the Pot Cover removed, place Selector Switch in the COOK position and note when burner(s) light. Allow 10 sec max. and return switch to the "OFF" position.
3. The wet heat exchanger should dry within 15 seconds after burner shut-off, indicating proper heating.
4. If burner(s) do not light or appear not to be heating, refer to the Troubleshooting guide.
5. If the Burner System is seems to be functioning properly, clean the fryer as described in the Boil-out Procedure instructions, Section 5-1.
6. After thorough cleaning, fill fry pot to proper level with shortening.

4-4. Filter Pump Test

The following test will ensure the Filter Pump is operation correctly.

1. Follow steps shown in Section 4-1.
2. Press the Power Switch to the ON 1 position.
3. Open Cabinet Door.
4. With the filter pan disconnected, place the palm of the hand over the 2 Quick Disconnect open for the Filter Pan Hose.
5. Briefly place the Selector Switch 3 in the PUMP position then back to the center the OFF 4 position. If suction is felt on the palm, the pump is operating correctly. Proceed to Section 4-5.

If no suction is felt, refer to the Troubleshooting procedure in Section 8-2.



4-5. Perform Boil Out Procedure

Perform a Boil-out Procedure to remove any dust, dirt or debris that may have accumulated during shipping. Follow Section 6-1 Boil Out Procedure. After performing the Boil Out Procedure proceed to Section 4-6.

4-6. Clean Filter Pan

Thoroughly clean the Filter Pan to remove any dust, dirt or debris that may have accumulated during shipping. Follow Section 6-2 Cleaning the Filter Pan and replacing Filter Paper after Boil Out.

Fryer preparation is now complete. Please proceed to the Operation Section.



Notes:

5. Fryer Operation

This section describes how to operate the Giles, Model GGF-400 & GGF-720 Gas Fryer.

DANGER

- Turn off the Fryer power switch and Fryer's main supply power at the main circuit breaker box before cleaning or performing maintenance.
- **DO NOT** wash down the Fryer's interior or exterior with water from a spray hose or any other pressure-type washing equipment.
- Failure to comply with these **DANGER** notices will result in death or serious injury, equipment/property damage and void the warranty.

CAUTION

- Ensure the Fryer is positioned in a secure, safe location with the casters in the locked position.
- Consult an electrician to ensure all electrical specifications have been met and the unit is properly grounded. The wiring diagrams included in this manual should aid an electrician with installation of the Fryer.
- Due to the high temperature of cooking oil in the Fryer during cooking, it is extremely important that the user exercise caution in operating this equipment to avoid personal injury.

5-01. Cooking Controller

The following section describes the functions, features and programming of the Cooking Controller.



5-01.1. Buttons and Functions



Use to set and display cooking temperature. Hold for 5 seconds to display current temperature.

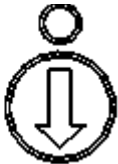
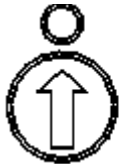

Use to increase or decrease cooking time and temperature, and to raise/lower basket. Also used to scroll through menu options.



Use to program, start, set, and recall cooking times.



Silences alarm.



Use to set cook times.

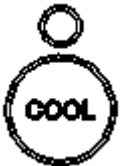

Use to activate and deactivate "Cool Mode" by pressing and holding for 5 seconds.



Use to activate "Boil Out" mode by pressing and for holding 5 seconds.



Use to activate basket elevator keys.

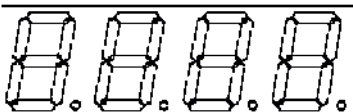

7-Segment Display - displays cooking time and temperature.

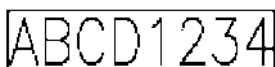

Scrolling Display - displays various status and alarm information.

5-01.2. Programming the Cooking Temperature and Time

To Begin Programming, Press Program Key For 5 Seconds



Upper Display To Read All
PROG

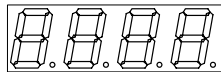

ABCD1234

Bottom Display To Read
Choose Menu

Press Button For Menu You Wish To Program



Upper Display To Read
FOOD

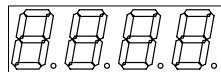

ABCD1234

Bottom Display To Read
Product Selections

Use Up And Down Arrow
Keys To Select Desired
Menu Item



OR



Select From Following Menu Labels:

BONE OUT WING	SPEC 1	FISH	CHEESE STIX	BREAST/THIGH
BONE IN WING	PICKLES	LIVERS	PIES	LEGS/WINGS
MENU * (BUTTON #)	CORNDOGS	CHICKEN	TATERS	TENDERS
SPEC 2	CATFISH	MUSHROOMS	FILLET	

Press Program Button to
Save Selection



**PROGRAMMING CONTINUED
ON NEXT PAGE**

**CONTINUE PROGRAMMING
FROM PREVIOUS PAGE**

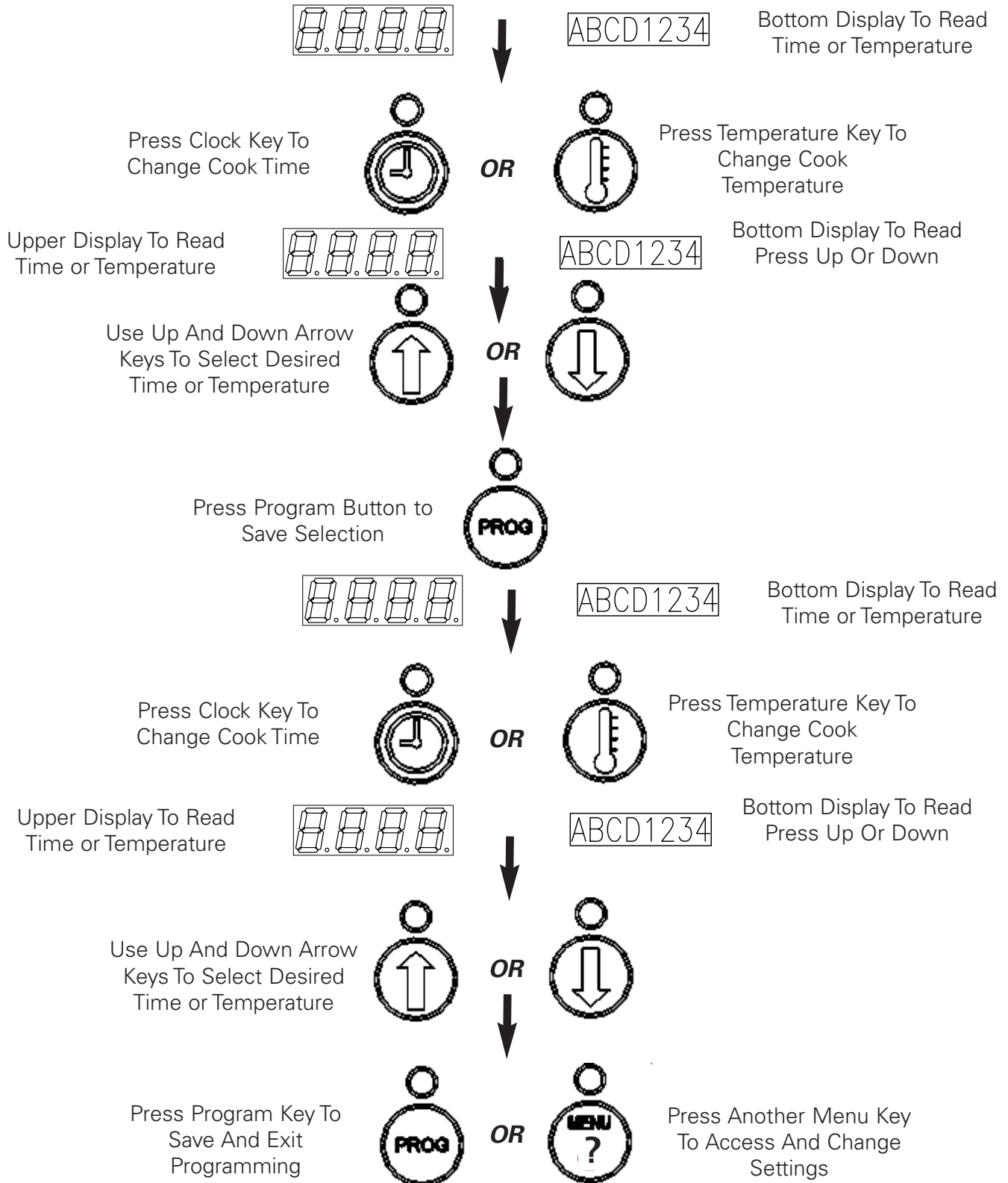

5-01.3. Entering Cook Cycle

Press Button For Menu You Wish To Run (Menu LED Will Illuminate and temperature will regulate to that setpoint)
Put product into the basket.

Press the Basket Key

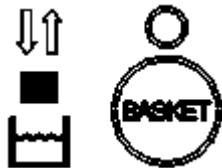

Press Down Arrow Key To Lower Basket



Press Button For Menu You Wish To Run (Menu LED Should Already Be Illuminated)



Upper Display To Read Current Setpoint (Holding temperature key for 5 seconds will display current temperature for 20 seconds)

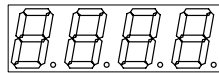

Bottom Display To Read Current Menu (Pressing Time Clock Key Will Display Remaining Time On Menu)

5-01.4. Exit Cook Cycle

Allow Active Timer To Complete Timed Cycle

OR

Press Button For Menu You Wish To Stop (Menu LED should already be illuminated.)



Upper Display To Read Current Setpoint (Holding temperature key for 5 seconds will display current temperature for 20 seconds)

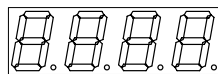

Bottom Display To Read Current Menu (Pressing Time Clock Key Will Display Remaining Time On Menu)



Up Arrow LED Will Illuminate, Alarm Will Sound, and Basket Will Raise

If Controller Goes Into Alarm State, Alarm Will sound, Basket Will Raise, and Message Will Display.

5-01.5 Entering Cool Cycle

To Begin Cool Cycle (Display Must Read "Ready"), Press Cool Key For 5 Seconds



Temperature Setpoint Will Change To 275 Degrees. No Menus can Be Activated In This State.

5-01.6 Exit Cool Cycle

To Exit Cool Cycle , Press Cool Key



Temperature Setpoint Will Change To Preheat To Begin Heating To Setpoint

5-01.7. Manually Lowering and Raising the Cooking Basket

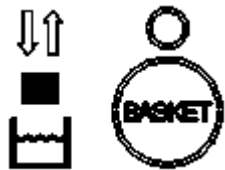

Press the Basket Key

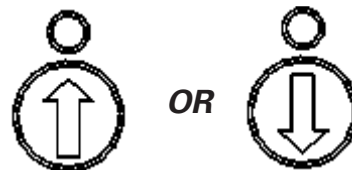

Use Up And Down Arrow Keys To Raise or Lower Basket

If Directional Arrow Has Been Pressed, 20 Second Timer Must Elapse Before Direction Can Be Changed..

5-01.8 Entering Boil Out Cycle

To Begin Boil Out Cycle (Display Must Read "Ready"), Press Boil Out Key For 5 Seconds



Temperature Setpoint Will Change To 200 Degrees. Basket Will Raise. No Menus can Be Activated In This State.

5-01.9 Exit Boil Out Cycle

To Exit Boil Out Cycle , Let 30 Minute Timer Expire and/or Cycle Power To Unit.

ABCD1234

Bottom Display To Read
Boil Complete
Cycle Power



Temperature Setpoint Will Change To Preheat To Begin Heating To Setpoint

5-2. Cooking Procedure

This section describes the cooking process as if beginning with cold shortening. This process may vary during repetitious cooking cycles or depending on the user's specific cooking procedures.

1. Raise and remove the Cooking Basket. See Section 5-1.7.
2. Ensure the Power Switch is in the OFF 1 position.
3. Ensure the Selector Switch is in the center OFF 2 position.



4. Ensure the Drain Valve is in the fully CLOSED 3 vertical position.
5. Fill the Fry Pot with liquid shortening only to the ADD 4 level. Fill only to this level; cold liquid shortening will expand as it is heated.

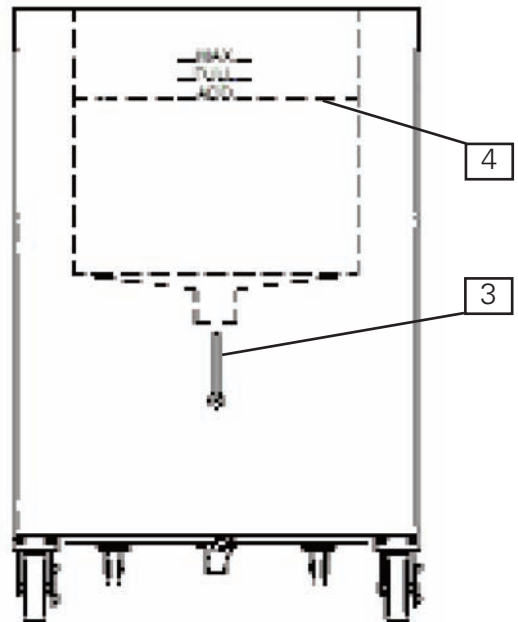

CAUTION

- Overfilling Fry Pot may result in spillage, potentially causing personal injury and/or equipment damage.

6. Place Power Switch in the ON 5 position. The Power Light 6 will illuminate.
7. Press the Menu Button 7 for the product to be cooked.
8. Place the Selector Switch in the COOK 8 position. The Heat Light 9 will illuminate.

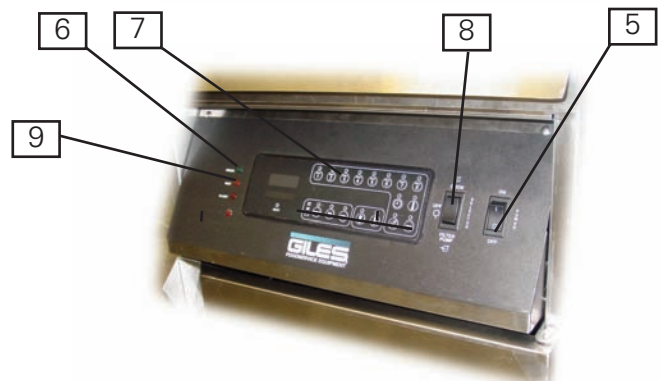

5-2. Cooking Procedure (Continued)

- 9. Use the supplied Stir Paddle and occasionally stir the shortening vigorously while Fryer is preheating. This will eliminate formation of cold spots, allowing for more even cooking of the product.
- 10. When shortening is preheated to the set-point temperature the Heat Light **10** will turn off. Check shortening level, it should now be close to the FULL **11** level. Add shortening if needed.
- 11. Vigorously stir shortening until the Heat Light **10** turns on again ... continue stirring until it turns off. At this point, shortening is at the programed set-point of the Menu Button selected and the Fryer should be ready to cook.

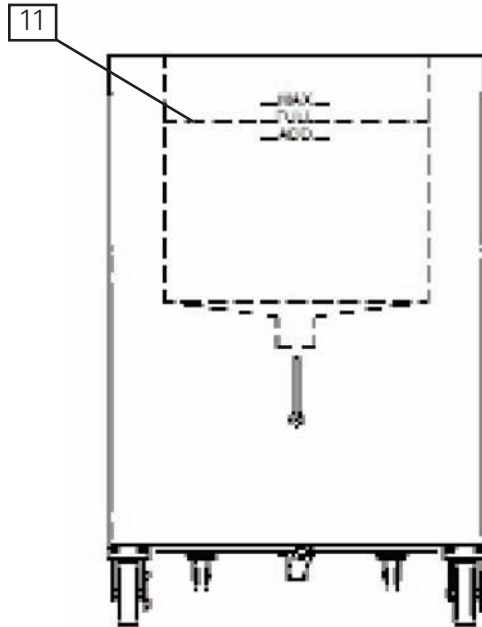

- 12. Place the Cooking Basket on the Basket Carrier **12**.

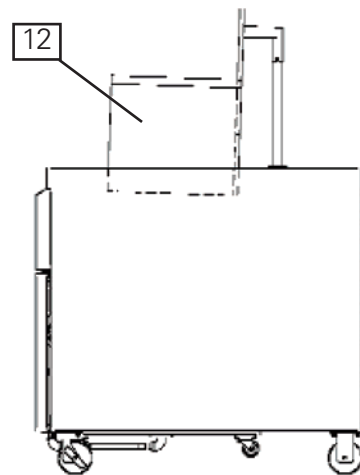

5-2. Cooking Procedure (Continued)

12. Uncooked product may be placed in the Cooking Basket **14** before or after the basket has been lowered into the shortening.

Use extreme caution when placing product into HOT cooking oil. HOT liquid shortening and any splash back from pot can cause severe burns.

Press "Basket" key and then "Down Arrow" key **15** to lower basket

Press the desired Menu Key **13** again to begin the programmed cooking time for the Menu Button selected.

Place the Pot Cover **16** on top of the cook vat.

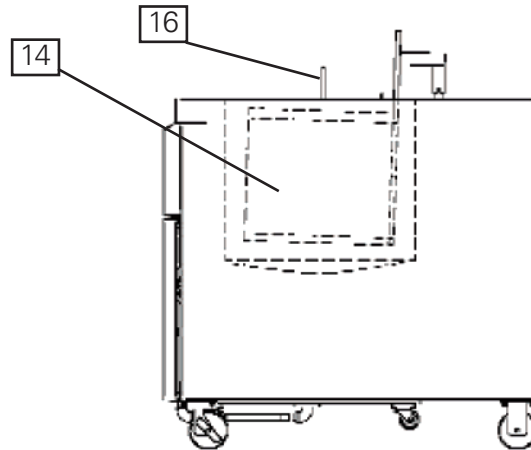

13. Controlled displays **17** remaining cook time and product selection.



5-2. Cooking Procedure (Continued)

14. When a pre-determined percentage of the selected cooking time has elapsed, the stir product alert will sound. Press the Alarm silence key to silence, then using oven mitts remove the Basket Cover **18** and stir the cooking product with the **19** Stir Paddle .
15. Replace the Basket Cover **18** .

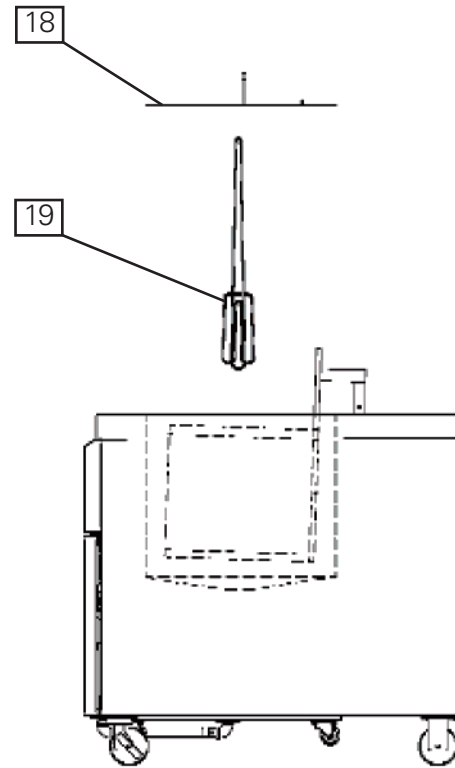

16. At the end of the cooking cycle the Cooking Basket **20** with the cooked product will automatically be lifted from the hot shortening.
17. Allow cooked product to adequately drain, then using oven mitts, remove the Basket Cover and then remove the Cooking Basket from the lift.
18. Place cooked product in an appropriate container.
19. Choose one of the following:
- a.) To continue cooking at this time return to Step-6 of this procedure.
 - b.) To place the Fryer in Cool Mode see Section 5-01.5, Cool Mode.
 - c.) To shutdown the Fryer, see Section 5-5, Normal Shut-Down.

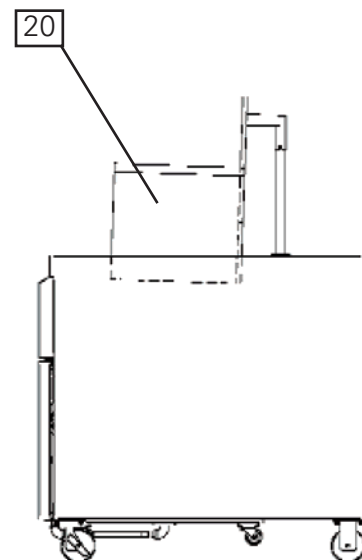

5-3. Filtering Liquid Shortening

This section describes use of the built-in filtration system to filter liquid shortening after several cooking cycles. This system circulates the used liquid shortening through the Filter Pan, Filter Paper and back to the Fry Pot. By following this process shortening life will increased by up to 50%. The Cooking Controller is preset to alert the operator to filter every fourth load cooked.

WARNING Never try to remove cold shortening using this procedure. This could clog the filter pump and damage the unit. Shortening must be heated to a minimum of 200°F (93°C) before performing this procedure.

1. After cooking the fourth load, Cooking Controller will display FILT **1** and the alert alarm will sound. This indicates that shortening requires filtering.
2. Press the Filter Button **2** to silence the alert.
3. Place the Selector Switch in the OFF **3** position.
4. Open the Cabinet Door. Wearing oven mitts, disconnect the Filter Pan Hose **4** from the quick-disconnect and remove the Filter Pan **5** from underneath the Fryer.
5. Ensure that Filter Pan contains properly installed Filter Paper. Only (1) sheet of paper is required.
6. Add one packet (4.8 oz) of filter powder into the Filter Pan, distribute evenly. (Product available from Giles - Part No. 72004)

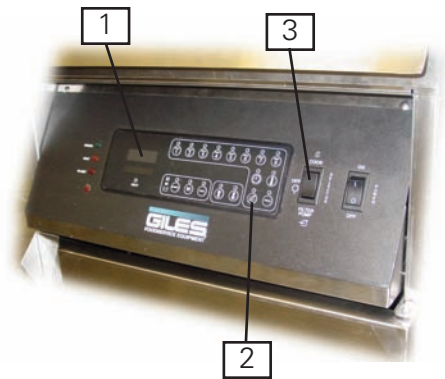

DANGER DANGER In this step liquid shortening is drained into the Filter Pan. Failure to ensure the fryer's Selector Switch is in the OFF position prior to draining may result in fire when the Heat Exchanger becomes exposed. ALWAYS ENSURE THE SELECTOR SWITCH IS IN THE OFF POSITION BEFORE DRAINING LIQUID SHORTENING.

7. Replace the Filter Pan Cover **6**, then reposition the Filter Pan under the Fryer. Reconnect the Filter Pan Hose **4** at the quick-disconnect.
8. Ensure the Selector Switch is in the OFF **3** position and that the Oil Diverter Valve handle is in the "TO VAT" **7** left-hand position. Slowly turn the Drain Valve Handle to the "OPEN" **8** or "up" position. This will allow liquid shortening to drain into the Filter Pan.

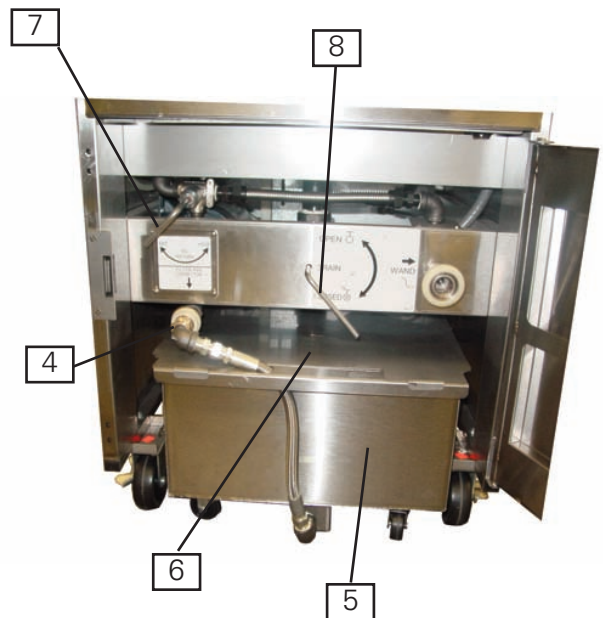

5-3. Filtering Liquid Shortening (Continued)

NOTE: If the Fry Pot does not drain, or drains very slowly, use the supplied Kettle Drain Brush to break up the crumbs & clean then from in the drain. **Be careful to not puncture the filter paper in the filter pan; this could cause the filter pump to clog and be damaged.**

9. When the Fry Pot has completely drained into the Filter Pan, place the Selector Switch in the FILTER 9 position.
10. The pump starts and shortening will be suctioned through the filter paper & recirculated 10 back to the Fry Pot . Leave the Drain Valve open and allow the shortening to continually circulate for a minimum of 5 minutes to ensure proper filtering. During this time use the Pot Brush to clean all crumbs and cooking residue from the pot bottom & heat exchanger.
11. After allowing shortening to circulate for a minimum of 5 minutes, turn the Drain Valve Handle to the CLOSE 11 or “down” position and allow the Fry Pot to refill.
12. After the Fry Pot has refilled, press the Selector Switch to the OFF 12 position.
13. Ensure the Fry Pot contains the proper level of Liquid Shortening, add if needed.
14. **Using Oven Mitts**, disconnect Filter Pan hose at quick-disconnect 13 and the remove the Filter Pan.
15. Using supplied Crumb Scoop 14, remove sediment from inside the Filter Pan.
16. Reinstall Filter Pan.
17. To continue cooking, See Section 5-2, Cooking Procedure.

To discontinue cooking, See Section 5-5, Normal Shut Down.

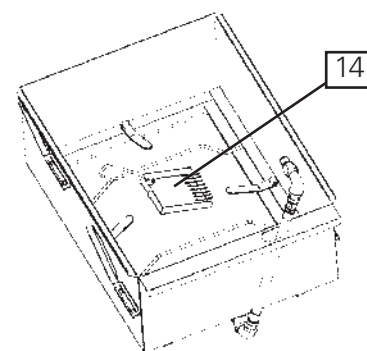
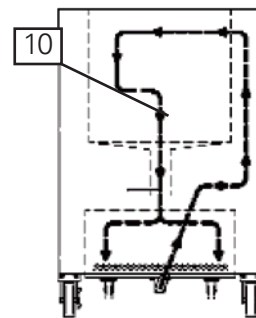

5-4. Removal of Liquid Shortening

This section describes how to remove liquid shortening from the Fryer in preparation for a Boil-out procedure or for disposal. The Giles Oil Caddy (not included) is referenced in this section for disposing of used shortening.

⚠ WARNING

Never attempt to remove cold shortening using this procedure, this could clog the filter pump and damage the unit. Liquid shortening must be heated to a minimum of 200°F (93°C) before following this procedure.

1. If shortening is cold, heat to 200°F (93°C).
2. Ensure the Power Switch is in the ON **1** position.
3. Ensure the Selector Switch is in the OFF **2** position.
4. Ensure the Filter Pan **3** is in place and the Filter Pan hose **4** is connected at the quick-disconnect.
5. Slowly turn the Drain Valve Handle to the OPEN **5** or "up" position and allow the Fry Pot to completely drain.

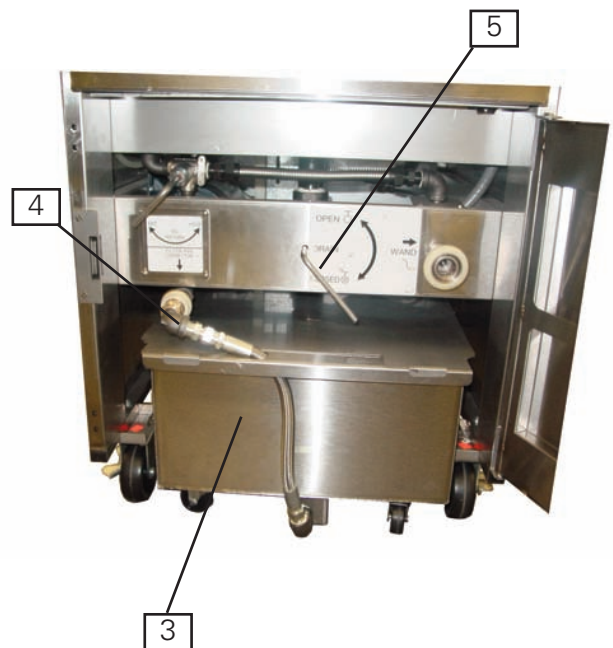
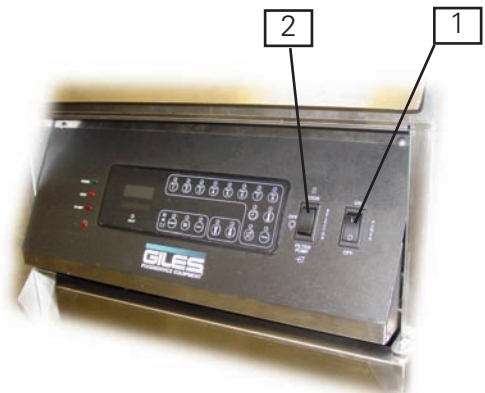

5-4. Removal of Liquid Shortening (Continued)

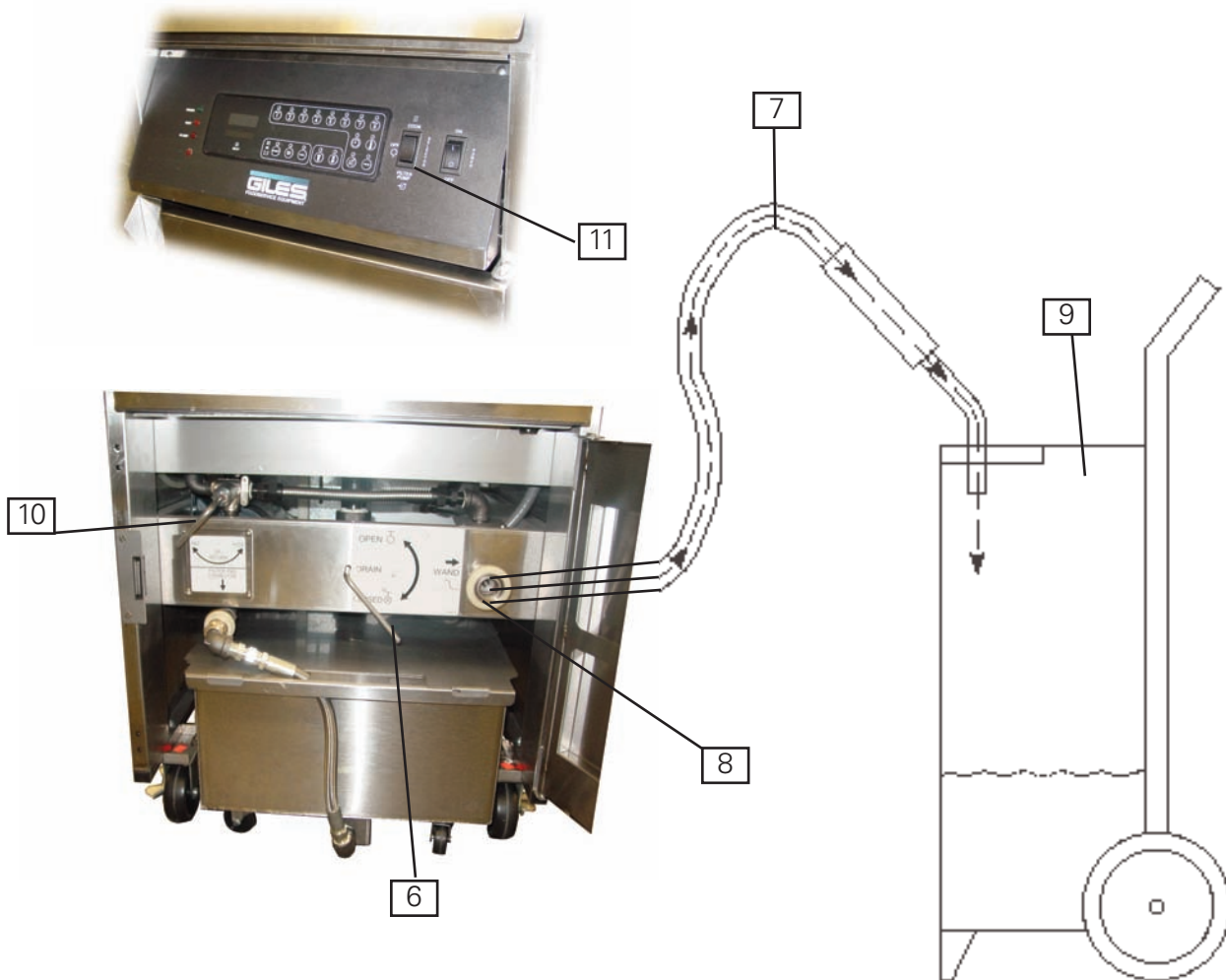

6. After the Fry Pot has completely drained, turn the Drain Valve Handle to the CLOSED [6] or "DOWN" position.
7. Connect the Oil Discharge Hose [7] to the quick-disconnect coupling [8].
8. Place the discharge end into a suitable Hot Oil Disposal Container [9] (Giles Oil Caddy is shown).
9. Turn the Oil Diverter Valve to the TO HOSE [10] or "RIGHT-HAND" position.
10. **Be sure the wear oven mitts if holding the Discharge Hose, as it will become very hot,** Press the Selector Switch to the PUMP/FILTER [11] position and pump liquid shortening into the Disposal Container. **IT IS ADVISABLE TO ATTEND TO THIS PROCESS, HOSE COULD VIBRATE FROM CONTAINER RESULTING IN HOT OIL SPILLAGE.**

5-4. Removal of Liquid Shortening (Continued)

11. After the Liquid Shortening is removed from the Filter Pan, place the Selector Switch in the OFF 12 position.
12. Place Power Switch in the OFF 13 position.
13. Turn the Oil Diverter Valve handle to the "TO VAT" 14 or "LEFT-HAND" position.
14. **Wearing oven mitts**, remove the Discharge Hose from the quick-disconnect coupling 15 and drain the any excess liquid shortening remaining in the hose into the Oil Disposal Container.
15. Thoroughly clean the Filter Pan and the Filter Pan Cover.
16. To perform a Boil Out on the unit see Section 6-1, Boil-Out Procedure.

To shut down the unit see Section 5-5, Normal Shut-Down.

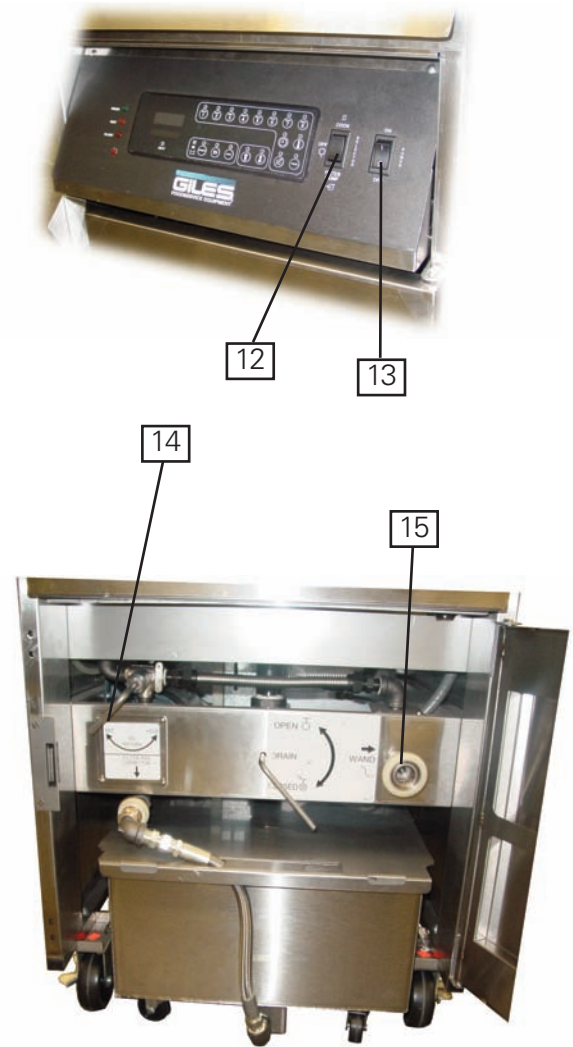

5-5. Normal Shut-Down

This section explains the process of shutting the unit down.

1. Place the Selector Switch in the center OFF 1 position.
2. Place the Power Switch in the OFF 2 position, Power Light 3 turns off.
3. If required, turn off the fryer circuit breaker at the main circuit breaker box to disconnect supply power to the Fryer.
4. Turn off gas supply valve.

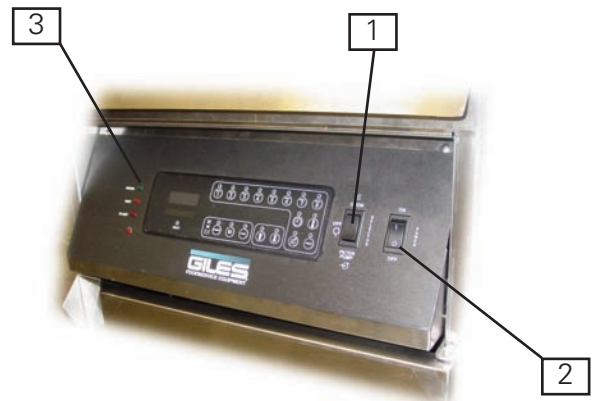

5-6. Emergency Shut-Down

In case of emergency, remove power to the unit by turning off the facility circuit breaker and shut off gas supply to unit..

6. Cleaning

This section describes the cleaning operations for the GGF-400 & GGF-720. The unit should be cleaned daily.

⚠ DANGER

- **DO NOT** wash down the Fryer's interior or exterior with water from a spray hose or any pressure-type washer.
- Failure to comply with these **DANGER** notices will result in death or serious injury, equipment/property damage, and void the warranty.

6-1. Boil-Out Procedure (Cleaning the Fry Pot)

This section describes how to clean the Fry Pot in the unit with a "Boil-Out" process. A "Boil-Out" must be performed before cooking on new equipment and should be performed each time the liquid shortening is removed from the unit, to be replaced with fresh.

For proper operation of the fryer, the Boil-Out procedure should be carried out, at a minimum, every 7 to 14 days.

⚠ DANGER

DO NOT under any circumstances leave the fryer unattended during this procedure as there is a potential for the vat overflow during the process. It may be necessary to adjust heat to prevent vat overflow. Overflow may result in serious equipment damage.

⚠ CAUTION

Never run Boil-Out solution, water, or any other cleaner through pump and filter system as it will result in equipment damage.

1. Remove liquid shortening from the unit. See Section 5-4; Removal of Liquid Shortening.
2. Confirm that the Drain Valve is in the CLOSED **1** "DOWN" position and the Power Switch is in the OFF **7** position.
3. Fill the Fry Pot with water to the "FULL" level **2**.
4. Follow the directions on the Boil-Out/Cleaner product being used ... add the recommend amount of product to the vat.

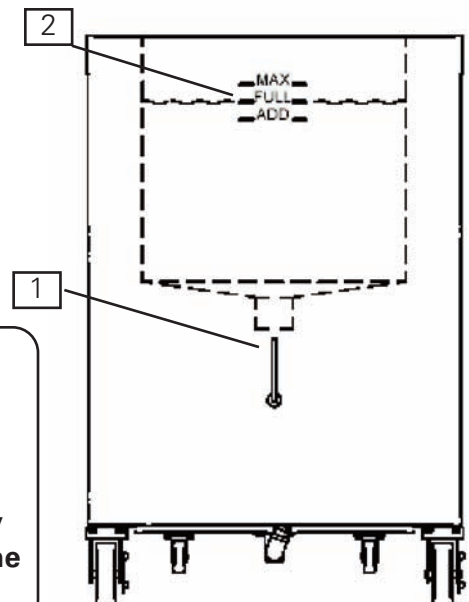

⚠ CAUTION

If using a product other than Giles Boil-Out (P/N 72003) pay close attention to the instructions listed on the container. Many commercially available cleaners are caustic requiring special precautions. If used improperly, these chemicals may cause damage to the fryer and potential personal injury to the user.

6-1. Boil Out Procedure (Continued)

5. Place the Power Switch in the ON 3 position.
6. Place Selector Switch in the HEAT 4 position.
7. Press & hold the Boil-Out button 5 on the Controller until the unit enters Boil-Out mode. The Boil-Out solution will heat to 200°F (93°C). See directions on Boil-Out container for suggested cycle time.
8. At the completion of the Boil-Out Cycle time place Selector Switch in the center OFF 6 position and Power Switch in the OFF 7 position.

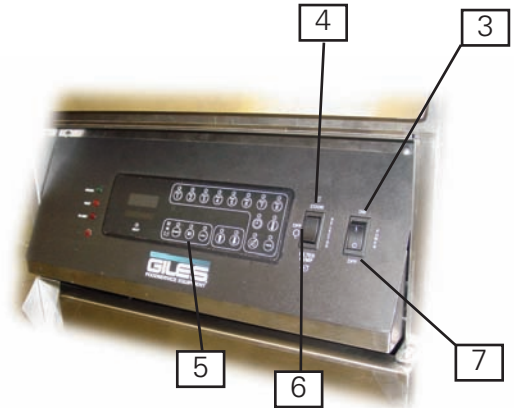

9. Disconnect Quick Disconnect Hose, remove the Filter Pan with Filter Pan Cover.

⚠ WARNING

DO NOT drain Boil-Out solution into the Filter Pan! Contents are corrosive and WILL CAUSE DAMAGE to the Filter Pan, Hold-Down Frame and Filter Pump. Failure to comply may result in minor or moderate personal injury, equipment or property damage, and void the warranty.

10. Position a suitable **Heat Resistant Container** 8 (not supplied with unit) beneath the fryer Drain as a catch container.

⚠ CAUTION

Use a catch container which is heat rated for up to 300°F (148°C). General-use plastic containers are typically not desirable as they may melt or break. A leak-proof metal container is preferable, but any container made of suitable high-temperature rated material may be used. Failure to comply with this caution may result in serious injury.



11. Slowly turn the Drain Valve Handle to the OPEN 9 "UP" position.
12. Rinse and flush the Fry Pot thoroughly with tap water.
13. Dry fry pot with a clean dry towel.

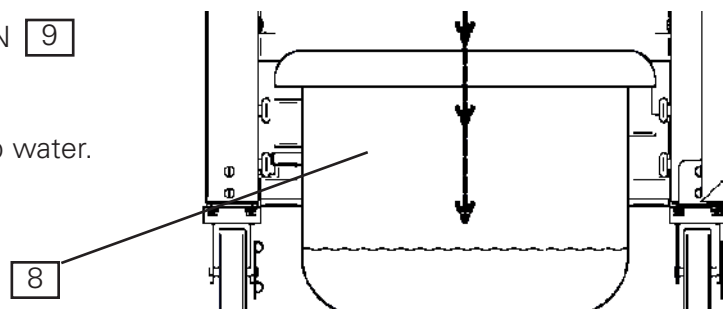

6-1. Boil Out Procedure (Continued)

14. Slowly turn the Drain Valve Handle to the CLOSE [10] "DOWN" position.
15. Clean Filter Pan and replace Filter Paper; follow directions in Section 6-2; Cleaning of Filter Pan Components after the Boil-Out procedure.
16. Replace Filter Pan Cover [11] on pan.
17. Position Filter Pan [12] under fryer and connect Filter Pan Hose [13] at quick-disconnect.
18. To begin cooking on the unit, see Section 5-2.

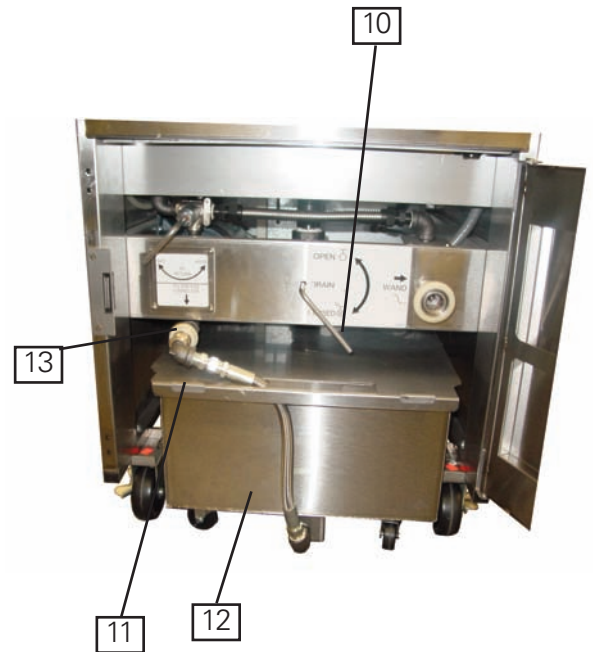

6-2. Cleaning the Filter Pan & Replacing Filter Paper after Boil-Out

This section explains the process for cleaning the Filter Pan and replacing Filter Paper. This process should be carried out each time a Boil-Out Procedure (Section 5-5) is performed.

Use Thermal Mitts for protection from hot parts.

1. Follow the Normal Shut-Down procedure, see Section 5-5.
2. Remove the Filter Pan **1** along with the Filter Pan Cover **2**.
3. Clean Filter Pan Cover **2** thoroughly.
4. If equipped, remove the Crumb Screen **3*** and clean thoroughly.
5. Using metal Crumb Scoop provided with the unit, remove the accumulated filter residue from around the edge of the Hold Down Frame **4** and surface of the Filter Paper **5**.
6. Turn the four Levers **6** to disengage the Hold-Down Frame **4** from the bottom of Filter Pan.
7. Remove the Hold-Down Frame **4**, clean and dry thoroughly.
8. Grasp one end of the Filter Paper **5** and carefully roll up sheet, then discard. Take care not to allow filter residue to fall through the perforated Support Screen **8** in Filter Pan bottom.
9. Thoroughly clean Filter Pan **7** and flush any debris from underneath Support Screen.
10. Reassemble the Filter Pan using new sheet of Filter Paper.
11. Reinstall Filter Pan Cover, replace Filter Pan assembly under fryer and connect at quick-disconnect.

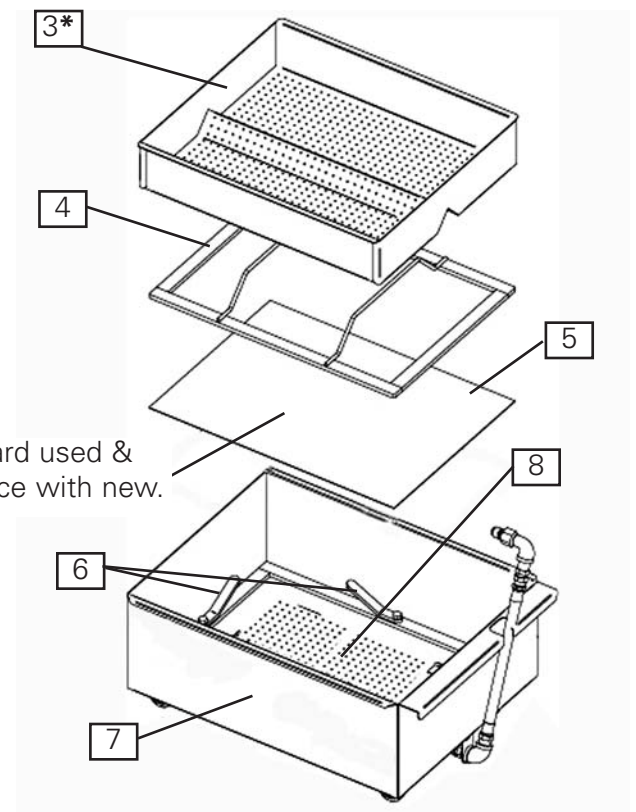
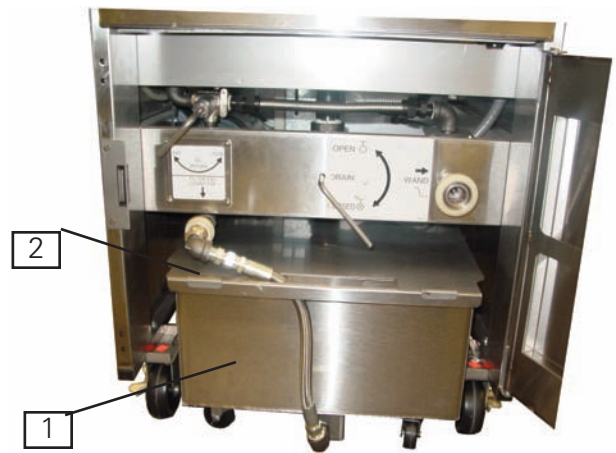

* Accessory Item, not included

6-3. Cleaning the Filter Pan and replacing the Filter Paper daily

This section explains the process of routine daily cleaning the Filter Pan and replacement of the Filter Paper. This process should be carried out daily, at a minimum.

Use Thermal Mitts for protection from hot parts.

1. Follow the Normal Shut-Down procedure, see Section 5-5.
2. Disconnect quick-disconnect hose, remove the Filter Pan **1** and the Filter Pan Cover **2**.
3. Clean Filter Pan Cover thoroughly.
4. If equipped, remove the Crumb Screen **3*** and clean thoroughly.
5. Using metal Crumb Scoop provided with the unit, remove the accumulated filter residue from around the edge of the Hold Down Frame and surface of the Filter Paper **5**.
6. Turn the four Levers **7** to disengage the Hold-Down Frame **4** from the bottom of Filter Pan.
7. Remove the Hold-Down Frame **4**, clean and dry thoroughly.
8. Grasp sheet of Filter Paper by one end, carefully roll up and discard. Take not to allow filter residue to fall through the perforated Support Screen **8** in Filter Pan bottom.
9. Thoroughly clean and dry the Filter Pan. Flush any filter residue from underneath Support Screen.
10. Reassemble the Filter Pan using new sheet of Filter Paper.
11. Reinstall Filter Pan Cover, replace Filter Pan assembly under fryer and connect at quick-disconnect.

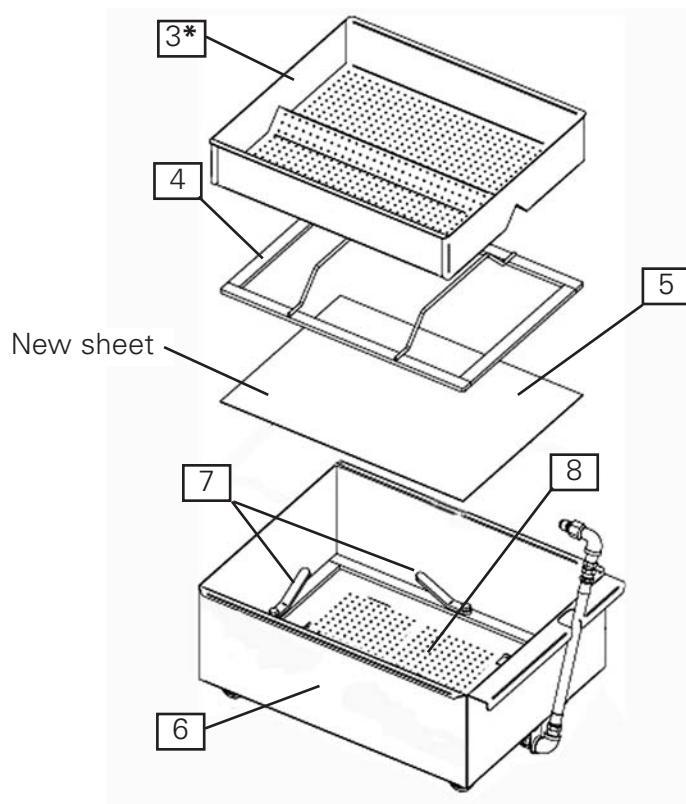
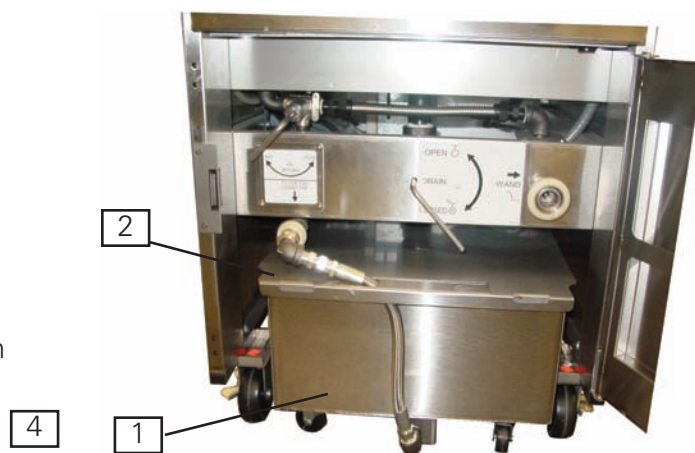

* Accessory Item, not included



Notes:

7. Troubleshooting

This section describes troubleshooting procedures for the Giles, Model GGF Gas Fryer. Refer to the wiring diagram included with this manual, as needed, for more detailed analysis (a diagram is also attached to the unit's Back Panel).

7-01. Temperature Control System		
Problem	Probable Cause	Repair Procedure
FRYER WILL NOT TURN ON: No power light	A. Not connected to power source.	A. Connect to power source.
	B. Faulty fuse or circuit breaker.	B. Check fuse or breaker.
	C. Fuse holder cracked.	C. Replace fuse holder.
	D. Faulty Power Switch.	D. Replace Power Switch.
	E. Improper supply voltage.	E. Connect to proper voltage source.
FRYER WILL NOT HEAT: Power light on. Heat light not on. (No alarm sounding)	A. Selector Switch not in cook position.	A. Place Selector Switch in cook position.
	B. Thermostat set lower than actual temp. of oil.	B. Set temperature controller to desired temperature.
	C. Drain Valve open.	C. Close Drain Valve.
	D. Cooking Controller faulty.	D. Replace Cooking Controller.
	E. Selector Switch faulty	E. Replace Selector Switch
	F. Variable probe shorted.	F. Replace Probe.
	G. Loose wire.	G. Repair loose wire.
	H. Vacuum Switch out of adjustment.	H. Adjust Vacuum Switch.
	I. Blower faulty.	I. Replace Blower.

7-01. Temperature Control System (Continued)

Problem	Probable Cause	Repair Procedure
<p>FRYER WILL NOT HEAT: Power light on. Heat light not on. Alarm Sounding.</p>	A. Fryer main gas line valve is CLOSED.	A. OPEN the main gas line valve.
	B. Fryer gas cock valve is CLOSED.	B. Turn Gas Cock handle to ON position.
	C. Faulty Flame Sensor.	C. Replace Flame Sensor.
	D. Flame Sensor alignment is incorrect.	D. Adjust Flame Sensor.
	E. Gas pressure incorrect.	E. Correct Gas Pressure.
	F. Orifice size incorrect.	F. Use correct orifice.
	G. Dirty Flame Sensor.	G. Clean Flame Sensor.
	H. Faulty Gas Valve.	H. Replace Gas Valve.
	I. Faulty Ignitor.	I. Replace Ignitor.
	J. Faulty Spark Module.	J. Replace Faulty Spark Module.
	K. Loose Wire.	K. Reattach Wire.
	L. Faulty Gas Valve Transformer.	L. Replace Gas Valve Transformer.
	M. Dirty Gas Burner.	M. Clean Gas Burner.
	N. Loose Ignitor Wire.	N. Reattach Ignitor Wire.
<p>FRYER WILL NOT HEAT: Power light on. High Limit light On.</p>	A. Power surge.	A. Turn Power Switch off for 5 seconds.
	B. Plug not completely in.	B. Reconnect to power source.
	C. Oil level too low.	C. Fill Fry Pot to correct oil level.
	D. Bad High Limit Board.	D. Replace High Limit Board.
	E. High Limit Probe shorted.	E. Replace High Limit Probe.
	F. Line spikes or noise in line.	F. Filter Line or remove noise source.

7-01. Temperature Control System (Continued)		
Problem	Probable Cause	Repair Procedure
FRYER HEATS SLOW: (slow recovery) Heat light stays on.	A. Incorrect Cooking procedures.	A. Consult Operations Manual for proper Cooking procedure.
	B. Burner system problem.	B. Check burner system.
	C. Incorrect gas pressure	C. Nat. = 4"wc LP = 11" wc
FRYER HEATS SLOW: (short cycling) Heat light off and on CONTINUOUSLY.	A. Low supply Voltage.	A. Supply proper Voltage.
	B. Variable probe touching heat exchanger.	B. Reposition variable probe.
	C. Cooking Controller faulty.	C. Replace Cooking Controller.
	D. Vacuum Switch out of adjustment.	D. Set Vacuum Switch correctly.
OIL TEMPERATURE ERRATIC:	A. Variable Probe bad.	A. Replace Variable Probe.
	B. Burner system problem.	B. Check burner system.
	C. Cooking Controller faulty.	C. Replace Cooking Controller.
	D. Loose Wire.	D. Repair loose Wire.
OIL SMOKING:	A. Old Oil.	A. Change Oil.
	B. Over Temperature.	B. Check temperature setting.
	C. Low Oil level.	C. Keep Oil at FULL Level.
	D. Filter Powder in Oil	D. Change Oil.

7-02. Oil Filtration System

Problem	Probable Cause	Repair Procedure
OIL NOT RETURNING TO FRY POT:	A. Selector Switch not in "Filter/Pump" position.	A. Place Selector Switch in "Filter/Pump" position.
	B. Air Leak (hose, fittings, filter paper).	B. Repair Air Leak.
	C. Pump Motor Bad.	C. Replace Pump Motor.
	D. Oil Pump Sticking.	D. Free Stuck Pump.
	E. Diverter Valve not in TO FRYER position.	E. Place Diverter Valve in TO FRYER position.
	F. Boil Out being run through Pump.	F. Disassemble and Re-Oil Pump.
	G. Old Oil allowed to sit in Pump.	G. Run Clean Oil through Pump.
	H. Oil in Filter Pan cold or below 200°F (93°C).	H. Remove Filter Pan and remove cold oil from Filter Pan.
	I. Filter Pan incorrectly assembled.	I. Assembly Filter Pan correctly.

7-03. Basket Elevator System

Problem	Probable Cause	Repair Procedure
BASKET WILL NOT GO UP OR DOWN:	A. Power not on.	A. Press Power Switch to ON position.
	B. Elevator Switch faulty.	B. Replace Elevator Switch.
	C. Cooking cycles running.	C. Cancel cooking cycle.
	D. Elevator micro-switch out of adjustment.	D. Adjust micro-switch.

8. Parts List

This section lists various replacement parts that are available for the Model GGF-400 and GGF-720 Gas Fryer.

8-1. Parts Ordering and Service Information

If you require assistance or need repairs, please contact your Giles Representative or Dealer to locate a service agency in your area. For further assistance, please contact the Giles Enterprises, Inc. corporate office:

US, CANADA or MEXICO: Please call **800-554-4537** between 8:00AM - 5:00PM Central Time; during other than normal business hours, please call **800-554-4537** and follow the recorded instructions to reach after-hours Technical Service support.

ALL OTHERS: Please call 334-272-1457 between 8:00AM - 5:00PM Central Time and follow the recorded instructions. During other than normal business hours, please call 334-272-1457 and follow the recorded instructions to reach after-hours Technical Service support.

INTERNET: Please visit our website at: **www.gfsequipment.com** or e-mail us at **services@gfsequipment.com**.

The goal of the Giles team is to provide you with the highest quality service and assistance possible. You can help us accomplish this by obtaining the following information and having it readily available when calling. The information is recorded on the Serial/Data Label attached to the fryer frame inside the front cabinet door.

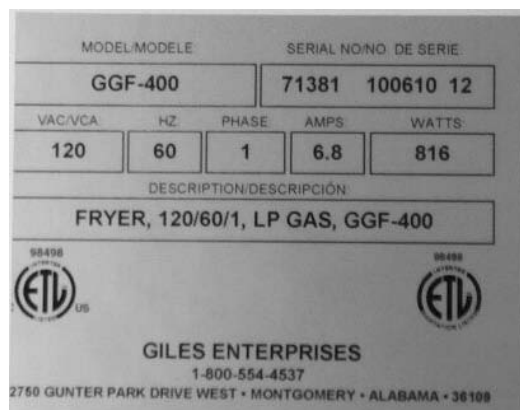

The area below may be helpful in recording information for use as a quick reference.

Model Number: _____

Serial Number: _____

Phase: _____

Voltage: _____

Nature of Problem: _____

8-2. Control Panel & Front Header

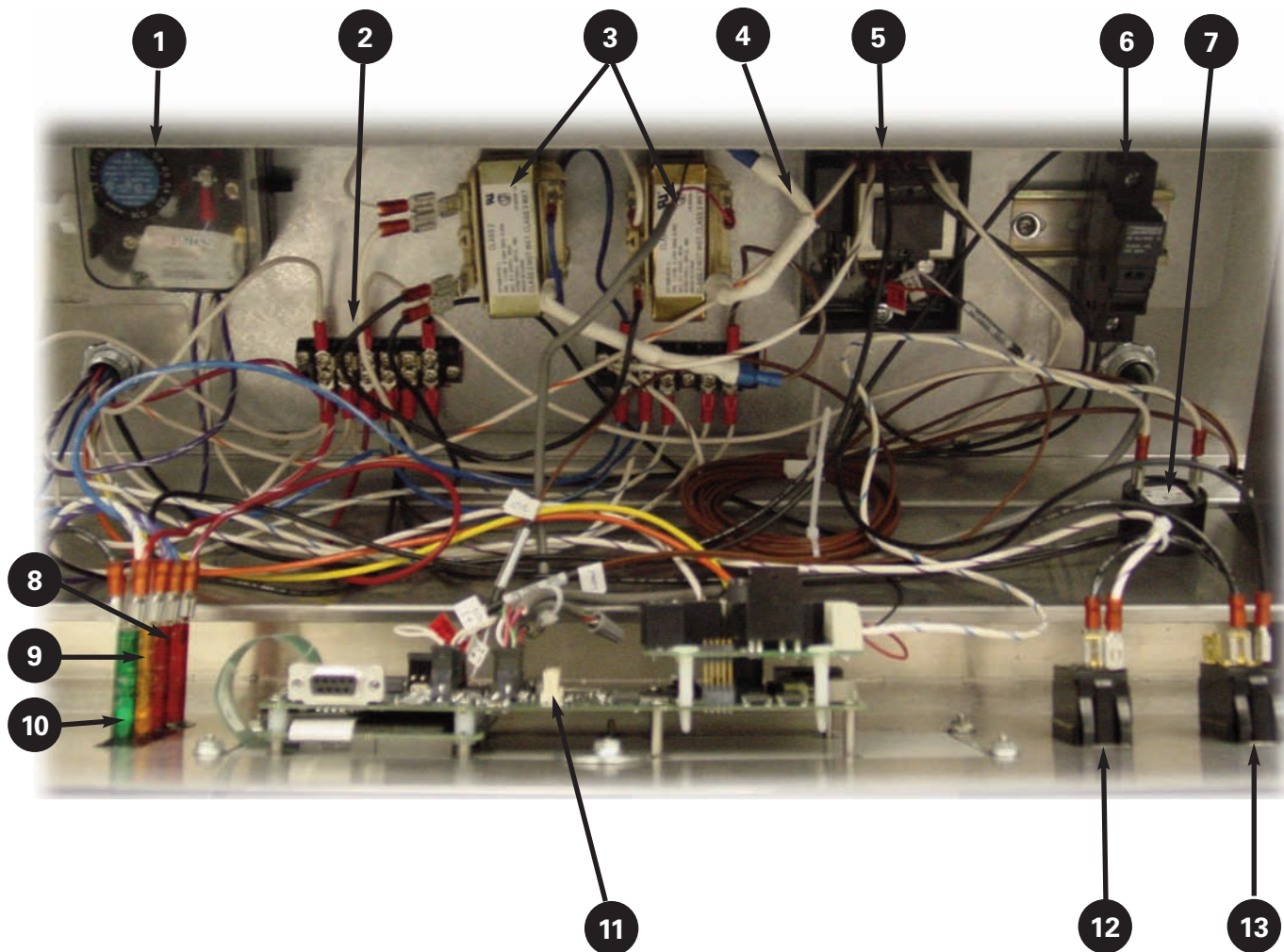

8-2. Control Panel & Front Header

Item	Part Number	QTY.	Description
1	20390	1	SWITCH, VACUUM
2	23751	2	TERMINAL BLOCK
3	24276	2	TRANSFORMER, 120VAC X 24VAC
3	24275	2	TRANSFORMER, 208/240VAC X 24VAC
4	38365	2	INLINE FUSE, 1A, HEAT SHRINKED
5	23749	1	THERMOSTAT, HI-LIMIT, WATLOW, 425DEG, 120VAC
5	23754	1	THERMOSTAT, HI-LIMIT, WATLOW, 425DEG, 208/240VAC
6	20411	1	FUSE HOLDER, DIN RAIL MOUNT
7	23782	1	SONALERT, 120VAC
7	23751	1	SONALERT, 230VAC
8	20428	2	LIGHT, INDICATOR, RED, 28V
9	20429	1	LIGHT, INDICATOR, ORANGE, 28V
10	20403	1	LIGHT, INDICATOR, GREEN, 120V
10	20398	1	LIGHT, INDICATOR, GREEN, 250V
11	20346	1	CONTROLLER, N7, WATLOW
12	21189	1	SWITCH, ROCKER, ON-OFF-ON, 250V, 20A, S.P.
13	21190	1	SWITCH, ROCKER, ON-OFF, 250V, 20A, D.P.

8-3. Front Lower Cabinet

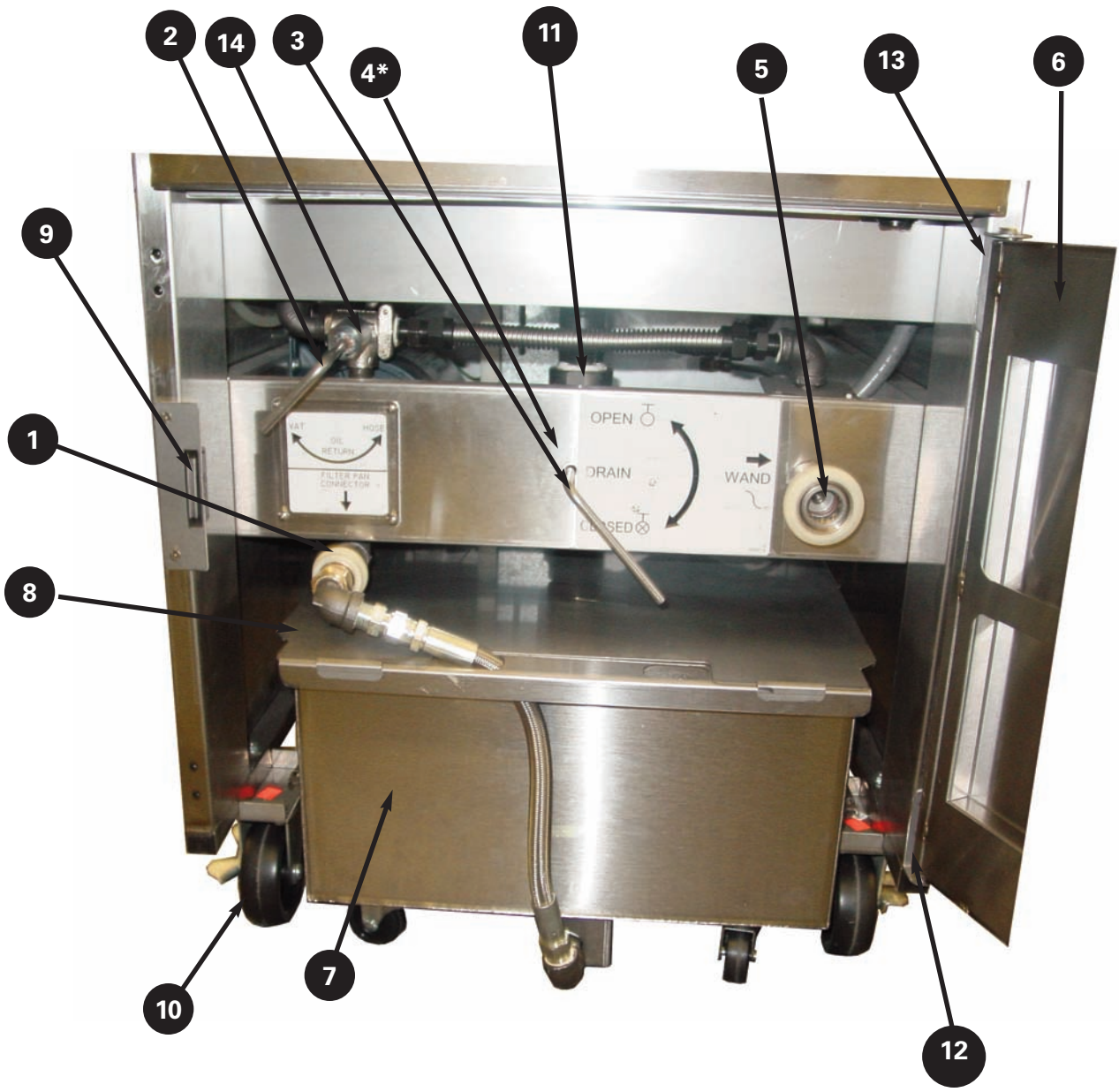

* Not shown

8-3. Front Lower Cabinet

Item	Part Number	Qty	Description
1	41900	1	COUPLING, QUICK DISCONNECT,FEMALE,FILTER PAN
2	90891	1	VALVE HANDLE, WELD ASSY, DIVERTER VALVE
3	91017	1	VALVE HANDLE, DRAIN, WELD ASSY, GGF
4*	21157	1	SWITCH, LIMIT, 15A, 250V DRAIN SWITCH
5	41699	1	COUPLING, QUICK DISCONNECT, FEMALE
6	38845	1	DOOR, WELD ASSY, GGF-400/560/720
7	38834	1	FILTER PAN, ASSY, GGF-400/560/720
8	90872	1	FILTER PAN COVER, WELDMENT, GEF
9	40851	1	CATCH, MAGNET, DOOR, SNAP IN, 2.3IN
10	40806	1	CASTER, 5.000, RIGID, W/BRAKE, GEF
11	45876	1	DRAIN VALVE, 1-1/2"NPT, GGF
12	90988	1	DOOR HINGE, BOTTOM, GGF-400/560/720
13	90989	1	DOOR HINGE, TOP, GGF-400/560/720
14	45755	1	VALVE, 3 WAY

* -Not shown

8-4. Rear Lower Cabinet

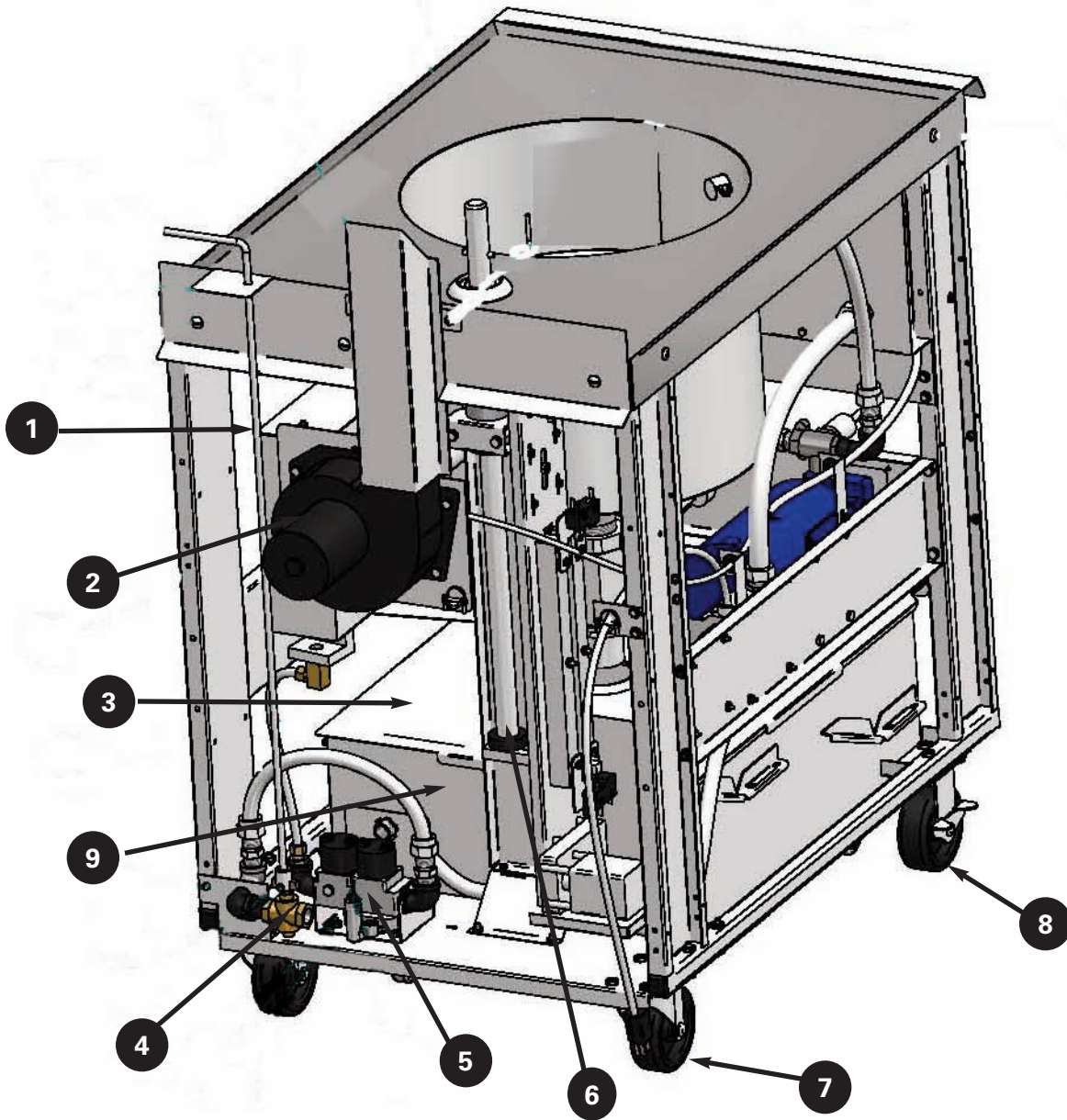

8-4. Rear Lower Cabinet

Item	Part Number	Qty.	Description
1	90893	1	HANDLE, GAS SHUT OFF VALVE
2	21801	1	BLOWER, DRAFT, 115V
2	21800	1	BLOWER, DRAFT, 208-240V
3	90872	1	COVER, FILTER PAN
4	34955	1	GAS COCK, SHUTOFF VALVE
5	91344	1	GAS CONTROL VALVE ASSEMBLY
6	91186	1	ELEVATOR ASSEMBLY, 120V
6	38827	1	ELEVATOR ASSEMBLY, 208/240V
7	40806	2	CASTER, 5.0, RIGID W/BRAKE
8	40807	2	CASTER, 5.0, SWIVEL W/O BRAKE
9	38834	1	FILTER PAN ASSEMBLY

8-5. Basket Cover and Basket

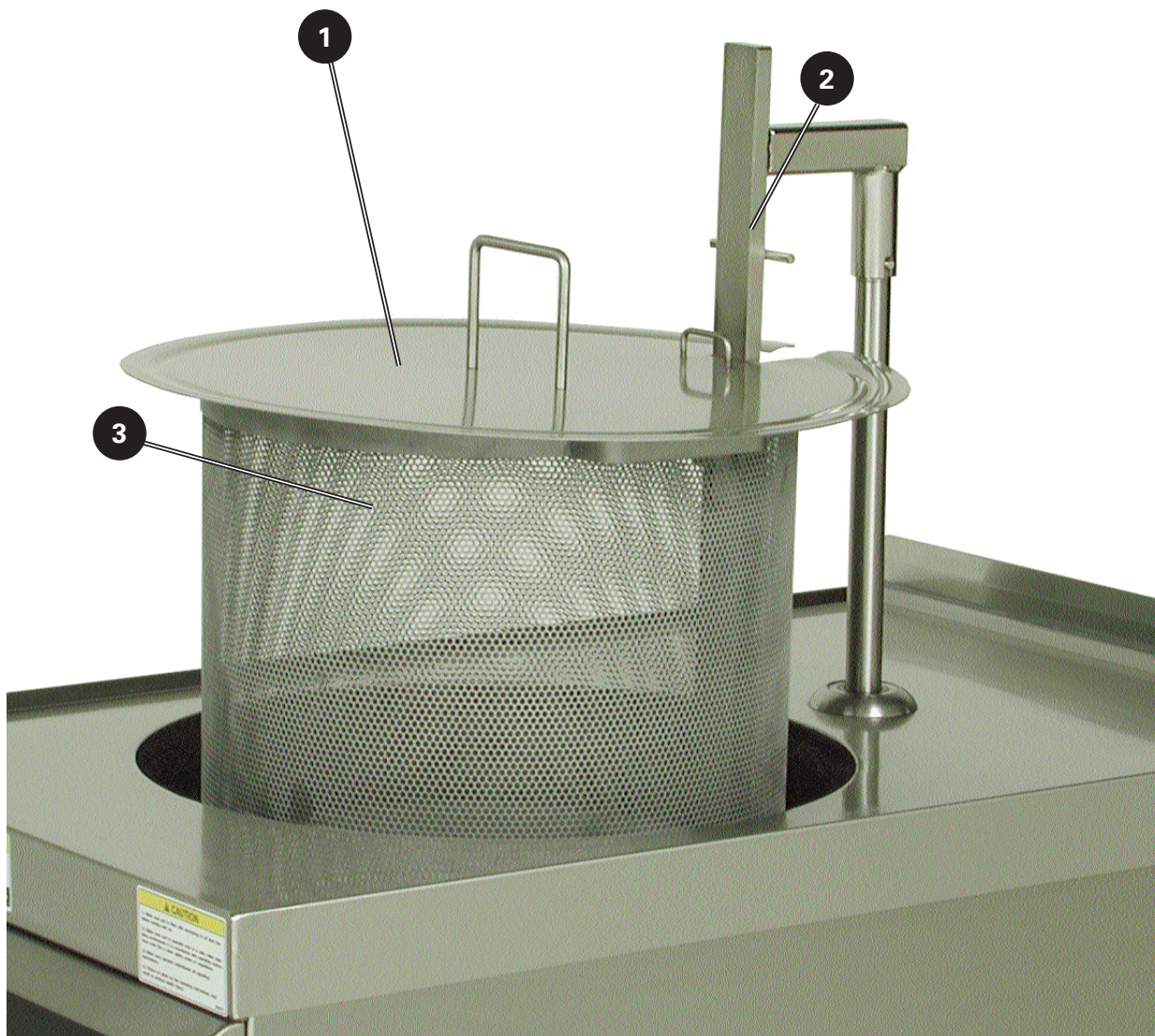



8-5. Basket Cover and Basket

Item	Part Number	Qty.	Description
1	33883	1	BASKET COVER, ASSY, GGF-720
1	33884	1	BASKET COVER, ASSY, GGF-400
2	38930	1	BASKET CARRIER, ASSY, GGF-720
2	39165	1	BASKET CARRIER, ASSY, GGF-400
3	91811	1	BASKET, WELD ASSY, GGF-720
3	33718	1	BASKET, WELD ASSY, GGF-400

8-6. Filter Pan

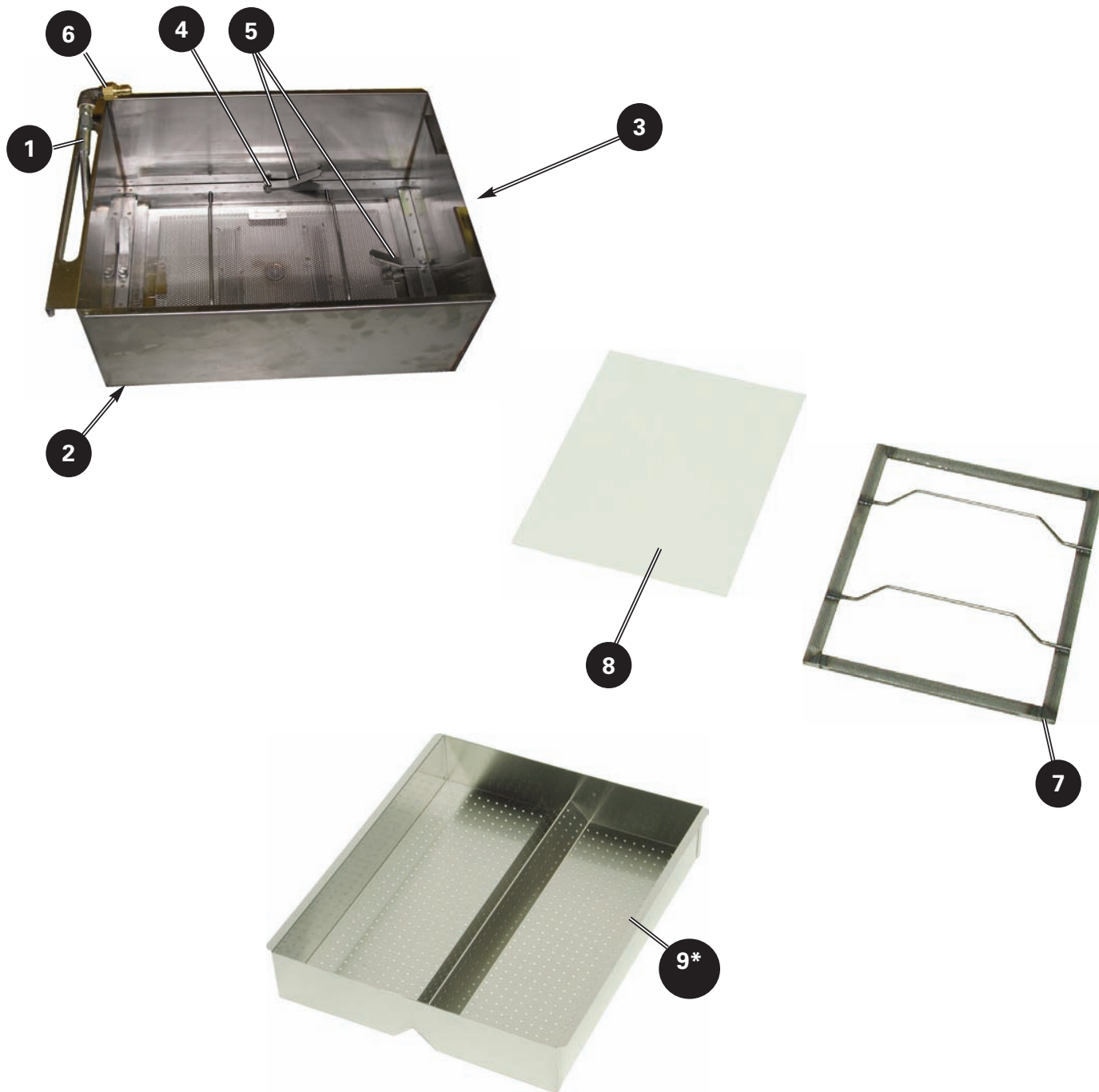

* Accessory item, Not included

8-6. Filter Pan

Item	Part Number	Qty.	Description
1	40955	1	HOSE, 1/2NPT X 15.75
2	40649	1	CASTER, SWIVEL, 2-9/16, FILTER PAN
3	38834	1	FILTER PAN, ASSY, GGF GAS FRYER
4	30040-4	4	STUD, FILTER PAN HOLD DOWN FRAME
5	38841	4	HANDLE, SUPPORT FRAME, FILTER PAN, GGF
6	44150	1	FITTING, BRASS,MALE,1/2NPT,QUICK DISCONNECT
7	38830	1	HOLD DOWN FRAME, WELD ASSY
8	60810	1	PAPER, FILTER, 21.375 X 15.500, GGF
9*	39246	1	CRUMB SCREEN, FILTER PAN, GGF
10	40956	1	HOSE, 1/2NPT X 11.500

* Accessory item, Not included

8-7. Plumbing

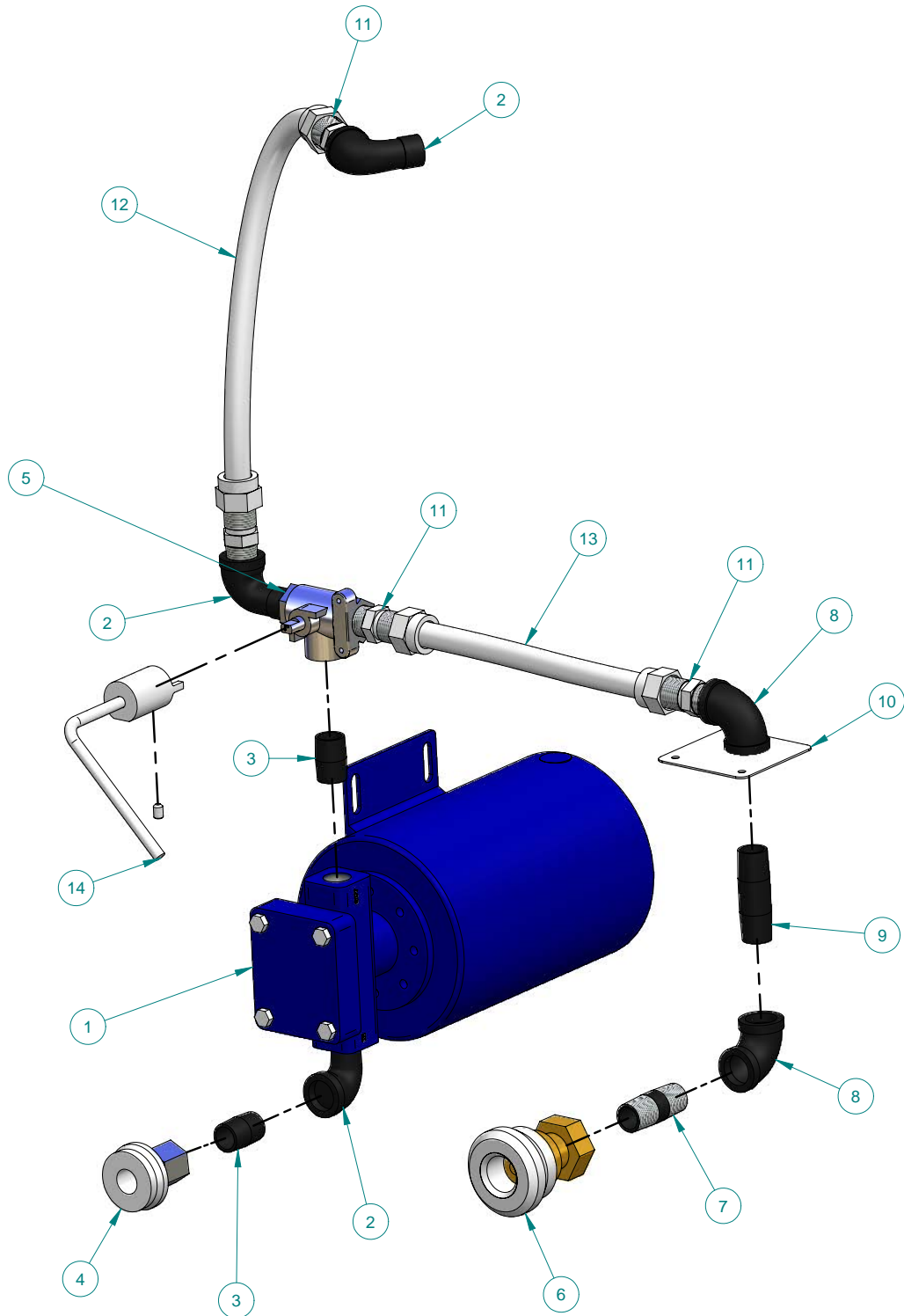

8-7. Plumbing

Item	Part Number	Qty.	Description
1	70912	1	PUMP AND MOTOR ASSY, VIKING
1	70910	1	PUMP ONLY
1	70911	1	MOTOR ONLY
2	42250	3	STREET ELL, BLACK, 1/2"
3	43850	2	NIPPLE, 1/2" CLOSE
4	41900	1	QUICK DISCONNECT, 1/2"
5	45755	1	3-WAY VALVE
6	41699	1	COUPLING, FEMALE QUICK DISCONNECT
7	43900	1	NIPPLE, 1/2" X 2"
8	42200	2	ELBOW, 1/2", BLACK
9	46753	1	NIPPLE, 1/2" X 2.5"
10	90870	1	BRACE, PIPE SUPPORT
11	40889	4	ADAPTER, 1/2" COMPRESSION X 1/2" PIPE THREAD -
12	40909	1	PIPE, CORRUGATED, 5/8" X 18"
13	40908	1	PIPE, CORRUGATED, 5/8" X 8.5"
14	90891	1	VALVE HANDLE ASSY, DIVERTER VALVE
15	10098	1	SET SCREW, 1/4-20, CUP PT.



Notes:



Giles Enterprises, Inc.

2750 Gunter Park Drive West • Montgomery, Al 36109 USA

334.272.1457 • Service Hotline: 800.554.4537 (USA & Canada Only) • FAX 334.239.4117 • www.gfsequipment.com

Form No. 65474 (Rev date: 10/12/2010)