

Operations & Service Manual

GEF-400, GEF-560, GEF-720,
GEF-400-VH, GEF-560-VH, &
GEF-720-VH



Models: GEF-400
GEF-560
GEF-720



Models: GEF-400-VH
GEF-560-VH
GEF-720-VH



Giles Enterprises, Inc.

An ISO9001 Registered Company

2750 Gunter Park Drive West • Montgomery, AL 36109 USA

Fax: (334) 272-3561 • Internet: www.gilesent.com

Service Hotline (Toll Free): 1-800-554-4537 (USA & Canada Only)

Form No. 60831 (Release date: 6/02/03)(Revision date: 09/06/07)(Rev D)

LIMITED WARRANTY

- Subject to the terms and conditions of this Limited Warranty as herein stated, all Giles Enterprises, Inc., Foodservice Equipment and parts purchased new from an authorized Giles Enterprises, Inc., representative are warranted as to defects in material or workmanship for a period of 12 months from the date of installation, provided, however, that with regard to labor costs in connection with this warranty, see below. All installations must be made by a qualified installing agency in accordance with all applicable codes and/or regulations in the jurisdiction in which installed. Limited warranty coverage is extended to the original owner only and is void if the unit is resold.
- During the Limited Warranty period, Giles Enterprises, Inc. will replace or recondition, at its factory, any part or parts of this unit which Giles Enterprises, Inc. inspectors judge defective, provided the unit has been subjected to normal usage, properly installed, operated and serviced. This Limited Warranty does not cover cosmetic damage, and damage due to acts of God, accident, misuse, alteration, negligence, abuse of the Giles Foodservice Equipment or the use of unorthodox repair methods. All parts replaced under this Limited Warranty carry only the unexpired term of this Limited Warranty. Limited Warranty service may be furnished only by an authorized Giles Enterprises, Inc., representative.
- If Limited Warranty service is requested, Giles Enterprises, Inc., will send factory-authorized service representatives to repair, recondition, replace or inspect units of its manufacture with such labor being rendered without cost to owner for ninety (90) days from the date of installation. Otherwise, service, including labor and transportation charges or other expenses, in connection with the removal or installation of any part or parts supplied under this Limited Warranty, are specified on the original sales contract between the purchaser and the authorized Giles Enterprises, Inc., representative.
- Giles Enterprises, Inc. reserves the right to change or improve its equipment and parts in any way without obligation to alter such equipment or parts previously manufactured.
- Giles Enterprises, Inc. makes no further warranties, express or implied including implied warranties of merchantability or fitness for a particular purpose, and has no other obligation or liability not specifically stated herein.
- Repair or replacement as provided under this limited warranty is the exclusive remedy. Giles Enterprises, Inc., shall not be liable for any incidental or consequential damages for breach of any express or implied warranty on this product, except to the extent prohibited by applicable law. Any implied warranty of merchantability or fitness for a particular purpose on this product is limited in duration to the duration of this limited warranty.
- Used Giles Enterprises, Inc., Foodservice Equipment or parts or Giles Enterprises, Inc., Foodservice Equipment or parts not purchased from an authorized Giles Enterprises, Inc., representative, carry no warranties, express or implied.

Table Of Contents

Model: GEF-400, GEF-560, GEF-720 &
GEF-400-VH, GEF-560-VH, GEF-720-VH

Safety	vii
Safety Overview	vii
Specific Safety Precautions	viii
1. Introduction	1
1-1. Construction	1
1-2. Standard Features	1
1-3. Optional Features	1
1-4. Specifications	2
1-4.1. Overall Dimensions for GEF-400, GEF-560, GEF-720	2
1-4.2. Overall Dimensions for GEF-400-VH, GEF-560-VH, GEF-720/VH	3
1-4.3. Regulatory Listings	4
1-4.4. Basket Sizes	4
1-4.5. Cooking Capacity	4
2. Installation	5
2-01. Location	5
2-02. Unpacking	6
2-03. Electrical Requirements	7
2-04. Electrical Connections	9
2-04.1. Routing conduit	9
2-04.2. Service Box Connections	10
2-05. Ventilation of Non-Ventless Fryer	10
2-06. Ventless Hood Clearances	10
2-07. Ventless Hood Fire Suppress System	11
2-08. Fusible Link and Gas Cartridge Locations	11
2-09. Fire Extinguisher Nozzle and Tank Locations	12
2-10. Fire Alarm Connection	13
2-11. Changing the Door Swing	14
3. Overview	15
3-1. Control Panel	16
3-2. Lower Cabinet Area	18
3-3. Filter Pan Assembly	20
3-4. Basket and Elevator Assembly	22
3-5. Ventless Hood (VH)	24
3-6. Accessories (Included)	26
3-7. Accessories (Not Included)	28
4. Unit Preparation	31
4-1. Settings before testing unit	31
4-2. Power test	32
4-3. Heating Element test	32
4-4. Filter Pump Test	33
4-5. Perform Boil Out Procedure	33
4-6. Clean Filter Pan	33

5.	Fryer Operation	35
5-1.	Cooking Controller	36
5-1.1.	Button and Function	37
5-1.2.	Programming a Cooking Temperature	38
5-1.3.	Programming a Cooking Time.	39
5-1.4.	Start a cooking cycle	40
5-1.5.	Cancel the current cooking cycle	40
5-1.6.	Displaying the current temperature of the liquid shortening	40
5-1.7.	Lowering and raising the cooking basket.	40
5-1.8.	Cool Mode	40
5-2.	Cooking Procedure	41
5-3.	Filtering Liquid Shortening	45
5-4.	Removal of Liquid Shortening	47
5-5.	Normal Shut-Down	50
5-6.	Emergency Shut-Down.	50
6.	Cleaning	51
6-1.	Boil-Out Procedure (Cleaning the Fry Pot)	51
6-2.	Cleaning the Filter Pan and replacing Filter Paper after Boil Out	54
6-3.	Cleaning the Filter Pan and replacing the Filter Paper daily	55
7.	Ventless Hood	57
7-1.	Hood Operation	57
7-2.	Filters	57
7-2.01.	Ventless Hood Filter Table	57
7-2.02.	Baffle Filter Removal.	58
7-2.03.	Baffle Filter Installation	59
7-2.04.	Baffle Filter Missing	60
7-2.05.	Baffle Filter Cleaning.	60
7-2.06.	EAC Filter Removal.	60
7-2.07.	EAC Filter Installation	61
7-2.08.	EAC Filter Status.	61
7-2.09.	EAC Filter Cleaning.	62
7-2.10.	Charcoal Filter Removal	62
7-2.11.	Charcoal Filter Installation	63
7-2.12.	Charcoal Filter Missing	63
7-2.13.	Charcoal Filter Replacement.	63
7-2.14.	Ultra Violet Lamp Cleaning	64
7-2.15.	Ultra Violet Lamp Removal	64
7-2.16.	Ultra Violet Lamp Installation	65
7-2.17.	Hood Filter Alarm Chart	65
7-3.	Maintenance.	66
7-3.1.	Monthly Interlock Check.	66
7-3.2.	Quarterly Hood Cleaning	66
7-3.3.	Semi-Annual Fire Suppression System	67
7-3.4.	Annual Fire Suppression System	67
7-3.5.	12 Year Fire Suppression System	67
7-3.6.	Maintenance & Service Log	68

Table Of Contents

Model: GEF-400, GEF-560, GEF-720 &
GEF-400-VH, GEF-560-VH, GEF-720-VH

8.	Troubleshooting	69
8-1.	Temperature Control System	69
8-2.	Oil Filtration System	72
8-3.	Basket Elevator System	72
8-4.	Ultimate Ventless	72
9.	Parts List	73
9-1.	Parts Ordering and Service Information	73
9-2.	Control Panel & Front Header	74
9-3.	Front Lower Cabinet	76
9-4.	Rear Lower Cabinet	78
9-5.	Basket Cover and Basket	80
9-6.	Filter Pan	82
9-7.	Front Ventless Hood	84
9-8.	Rear Ventless Hood	86
10.	Wiring Diagram	89
10-01.	Wiring Diagram GEF-400 208-240/60/1 Computer	90
10-02.	Wiring Diagram GEF-400 208-240/60/3 or 220/50/3 Computer	92
10-03.	Wiring Diagram GEF-560 208-240/60/1 Computer	94
10-04.	Wiring Diagram GEF-560 208-240/60/3 or 220/50/3 Computer	96
10-05.	Wiring Diagram GEF-720 208-240/60/3 or 220/50/3 Computer	98
10-06.	Wiring Diagram GEF-720 480/60/3 Computer	100
10-07.	Wiring Diagram GEF-400-VH 208-240/60/1 Computer	102
10-08.	Wiring Diagram GEF-400-VH 208-240/60/3 or 220/50/3 Computer	104
10-09.	Wiring Diagram GEF-400-VH 208-240/60/1 W/ UV	106
10-10.	Wiring Diagram GEF-400-VH 208-240/60/3 W/ UV	108
10-11.	Wiring Diagram GEF-560-VH 208-240/60/1 Computer	110
10-12.	Wiring Diagram GEF-560-VH 208-240/60/3 or 220/60/3 Computer	112
10-13.	Wiring Diagram GEF-560-VH 208-240/60/1 W/ UV	114
10-14.	Wiring Diagram GEF-560-VH 208-240/60/3 W/ UV	116
10-15.	Wiring Diagram GEF-720-VH 208-240/60/3 or 220/50/3 Computer	118
10-16.	Wiring Diagram GEF-720-VH 480/60/3 Computer	120
10-17.	Wiring Diagram GEF-720-VH 208-240/60/3 W/ UV	122
10-18.	Wiring Diagram GEF-720-VH 480/60/3 W/ UV	124

**Model: GEF-400, GEF-560, GEF-720 &
GEF-400-VH, GEF-560-VH, GEF-720-VH**

Table Of Contents



Notes:

Safety

Safety Overview

The instructions contained in this manual have been prepared to aid you in learning the proper procedures for installing and servicing your new Giles equipment, Model GEF-400, GEF-560, GEF-720, GEF-400-VH, GEF-560-VH and GEF-720-VH.

Throughout this manual, safety precautions are identified through the use of the safety alert symbol and three signal words: **DANGER, WARNING**, and **CAUTION**. All safety alert information precedes the step(s) to which they apply. Suggested, recommended, or other noteworthy information is identified through the use of **NOTES**. Additionally, certain words are used to indicate a specific meaning or to add emphasis.

The following words are used as indicated throughout the manual:

Shall: understood to be mandatory.

Should: understood to be advisory.

May: understood to be permissive.

Will: indicates a future event/condition to occur.

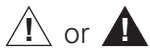

Used in conjunction with signal words (**DANGER, WARNING**, or **CAUTION**) to alert you of potential personal injury hazards, immediately preceding precautionary measures that pertain to subsequent step(s). Obey all safety messages that follow this symbol to avoid possible injury or death. Failure to adhere to safety precautions identified by the safety alert symbol may also void the warranty.

DANGER

- Indicates an imminently hazardous situation which, if not avoided, will result in death or serious injury.

WARNING

- Indicates a potentially hazardous situation which, if not avoided, could result in death or serious injury.

CAUTION

- Indicates a potentially hazardous situation which, if not avoided, may result in minor or moderate injury. Also used to alert against unsafe practices.

CAUTION

- When used without the safety alert symbol, **CAUTION** indicates a potentially hazardous situation which, if not avoided, may result in equipment/property damage, and void the warranty.

NOTE:

- Identifies suggested, recommended, or other noteworthy information.

Specific Safety Precautions

For your safety, please observe the following precautions when operating or servicing your Giles equipment, Model GEF-400, GEF-560, GEF-720, GEF-400-VH, GEF-560-VH and GEF-720-VH. Read the following important safety information to avoid personal injury and/or damage to the equipment.

 **DANGER**

- Turn off the unit and unplug the power cord before cleaning or performing maintenance.
- **DO NOT** hose down the GEF-400, GEF-560, GEF-720, GEF-400-VH, GEF-560-VH or GEF-720-VH interior or exterior with water.
- Failure to comply with these **DANGER** notices will result in death or serious injury, equipment/property damage, and void the warranty.

 **WARNING**

- Consult a qualified electrician to ensure that:
 - all electrical specifications and codes are met.
 - circuit breakers and wiring are of sufficient rating and gauge.
- The GEF-400, GEF-560, GEF-720, GEF-400-VH, GEF-560-VH and GEF-720-VH must be properly grounded and all electrical specifications must be met during installation.
- Improper installation, adjustment, alteration, service or maintenance could result in death or serious injury, equipment/property damage, and void the warranty.
- **DO NOT** use or store gasoline or other flammable liquids or vapors in the vicinity of this or any other appliance!
- Failure to comply with **WARNING** notices could result in death or serious injury and equipment/property damage and void the warranty.

 **WARNING**

- Internal ultraviolet radiation source
- Keep protective barrier in place.
- Replace all removable parts after servicing.
- An interlock is provided to reduce exposure to excessive ultraviolet radiation. **DO NOT** defeat the purpose of the interlock.

Safety

**Model: GEF-400, GEF-560, GEF-720 &
GEF-400-VH, GEF-560-VH, GEF-720-VH**

CAUTION

- The GEF-400, GEF-560, GEF-720, GEF-400-VH, GEF-560-VH and GEF-720-VH must remain in the upright (vertical) position.
- Exercise care when removing the wooden crate from around the unit.
- **DO NOT** operate the GEF-400, GEF-560, GEF-720, GEF-400-VH, GEF-560-VH or GEF-720-VH unless you fully understand the components and their intended function (see Section 3).
- The GEF-400, GEF-560, GEF-720, GEF-400-VH, GEF-560-VH and GEF-720-VH and its parts are HOT! Temperatures inside the unit may exceed 150°F (65.5°C). Exercise caution when operating, loading/unloading food, cleaning or servicing. Wearing of thermal oven mitts is recommended.
- Failure to comply with **CAUTION** notices may result in minor or moderate injury, equipment/property damage, and void the warranty.

CAUTION

- Food products must be maintained at a temperature of 150°F (65.5°C) minimum or in accordance with local or state health regulations.
- **Fryers must be adequately and properly grounded. Improper grounding may result in electrical shock. Always refer to your local electrical code to ensure proper grounding of this or any other electrical equipment. Always consult with an electrician or other qualified service person to ensure breakers and wiring are of sufficient rating and gauge for the equipment being operated.**
- Giles Electric Fryers are available from the factory wired for various voltage, phase and hertz. Check the rating plate on the front of the fryer to determine the correct power supply.
- Ensure the fry kettle is positioned in a secure, safe location with the casters in the locked position.
- Consult an electrician to ensure all electrical specifications have been met and the unit is properly grounded. The wiring diagrams contained in this manual should aid your electrician in the installation of your fryer.
- Due to the high temperature of shortening in your fryer during cooking, it is extremely important the user exercise caution in operation this equipment to avoid personal injury.
- Before attempting to operate the unit, refer to Section 3 to familiarize yourself with the various control functions. Once you have read and fully understand Section 3, please follow the steps below precisely in order to prevent equipment damage or malfunction.
- Be careful not to puncture the filter paper when using the brush to unclog the Drain Valve.
- Allow the unit to cool down a minimum of 15 minutes before cleaning or servicing.
- Be careful not to bend the fins or break the ionizer wires on the Electrostatic Air Cleaner (EAC) as this will prevent the EAC from working properly and shut off the power to the appliance.

CAUTION

- The electronic components of the Control Panel are impact-sensitive. Exercise care around the Control Panel to maintain proper operation.
- **DO NOT** install the unit next to combustible walls and materials. Failure to maintain safe distances may result in fire.
- During cleaning of the GEF-400, GEF-560, GEF-720, GEF-400-VH, GEF-560-VH and GEF-720-VH:
 - **DO NOT** steam clean.
 - **DO NOT** use products containing chlorine.
 - **DO NOT** use abrasive products, steel wool or scouring pads.
 - **DO NOT** use oven cleaner.
- Failure to comply with these **CAUTION** notices may result in equipment/property damage and void the warranty.
- Failure to comply may violate local health codes.
- **DO NOT** Modify, Alter or Add Attachments to This Equipment!

Note:

- If the crate is damaged upon receipt, immediately inspect the GEF-400, GEF-560, GEF-720, GEF-400-VH, GEF-560-VH or GEF-720-VH and notify the carrier of any damage to the unit.
- To aid the electrician, an electrical wiring diagram is contained in this manual. Refer to the wiring diagram during installation or servicing.
- Comply with all appropriate state and/or local health regulations regarding the cleaning and sanitation of equipment.
- The decibel level of the hood when operating is approximately 65 dB's.
- Never attempt to clean the Charcoal Filter.
- The appliance and plenum nozzles have been factory installed in the proper operating position. **DO NOT MOVE OR ADJUST.**

Introduction

**Model: GEF-400, GEF-560, GEF-720 &
GEF-400-VH, GEF-560-VH, GEF-720-VH**

1. Introduction

Congratulations on the purchase of your new Giles equipment, Model GEF-400, GEF-560, GEF-720, GEF-400-VH, GEF-560-VH, and GEF-720-VH, manufactured by Giles Enterprises, Inc., Montgomery, Alabama (USA), hereafter referred to as "Giles". Every unit is thoroughly inspected and tested prior to shipment. Proper care and maintenance will ensure years of trouble-free service.

To help protect your investment in this state-of-the-art cooking equipment, we recommend you take a few moments to familiarize yourself with the installation, cleaning and maintenance procedures contained in this manual. Adherence to these recommended procedures minimizes the potential for costly "Down-Time" and equipment repairs. Please retain this manual for future reference.

1-1. Construction

Model GEF-400, GEF-560, GEF-720, GEF-400-VH, GEF-560-VH, GEF-720-VH, is constructed of stainless steel.

1-2. Standard Features

Temperature Controller -used to control the temperature of the cooking oil and the amount of cooking time.

Automatic Basket Lift -used to automatically lift cooked product from hot cooking oil at the end of the cooking cycle.

Oil Filtration System -used to extend the life of cooking oil.

Ventless Hood Unit Only

Ventless Hood -used to remove particulates from the air without using a vent to the outside.

Extinguishing System -built into the hood to extinguish an accidental fire from the cooking oil.

1-3. Optional Ventless Hood Features

Ultimate Ventless: Ultra Violet light in conjunction with Giles patented air filtration system improves emission cleaning and odor control as well as keeping the unit free from grease build up.

Interlocking Start System (ILS) -Interlocking Start System (ILS) -This system will cause the Hood and the Appliance below the Hood to shut down when the hood filters need to be cleaned or are not properly installed. ILS is required by some cities and/or states. Please check with your local code officials to see if this system is required.

1-4. Specifications

1-4.1. Overall Dimensions for GEF-400, GEF-560, GEF-720

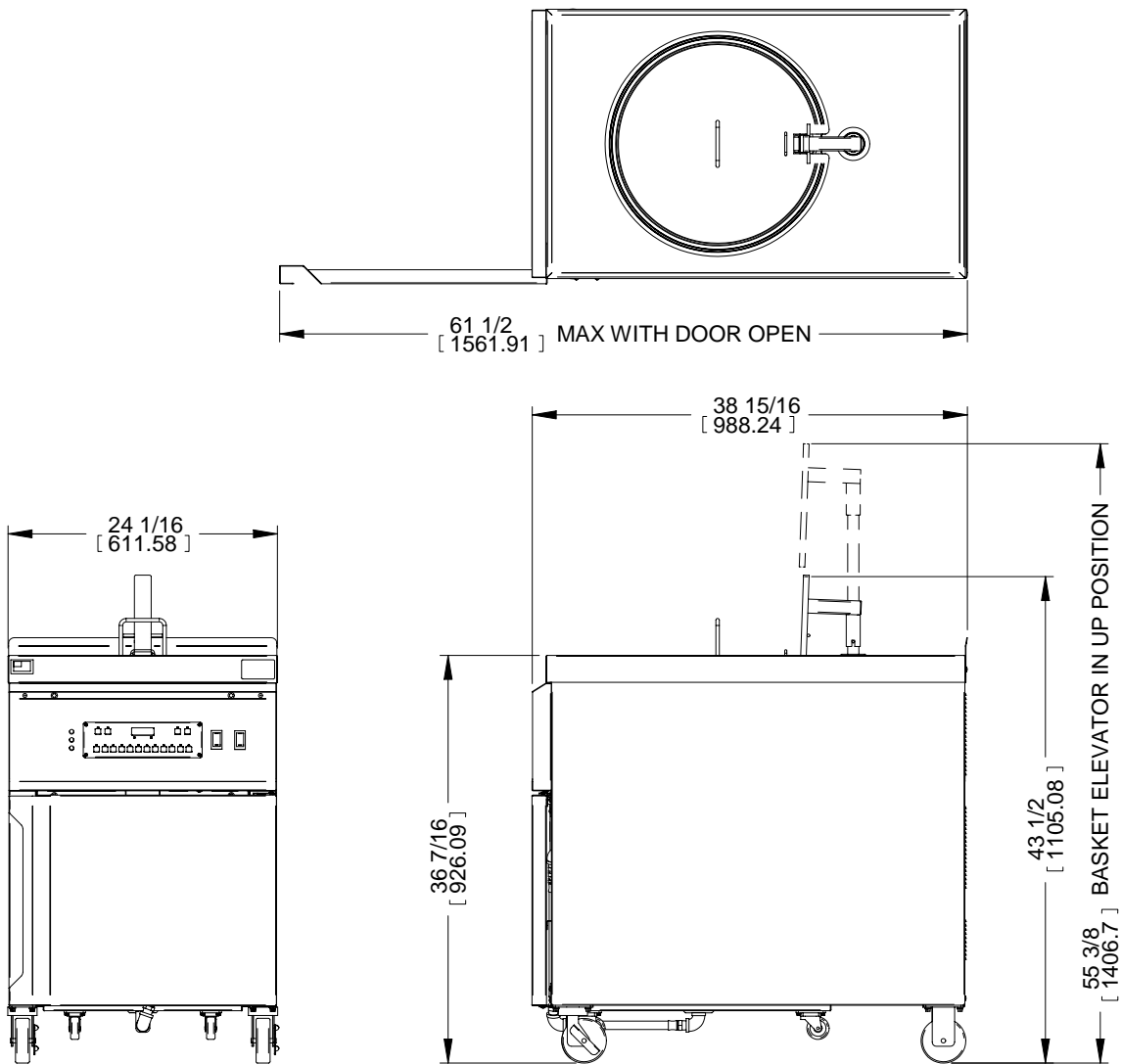

INCHES [MILLIMETERS]

Introduction

Model: GEF-400, GEF-560, GEF-720 &
GEF-400-VH, GEF-560-VH, GEF-720-VH

1-4.2. Overall Dimensions for GEF-400-VH, GEF-560-VH, GEF-720/VH

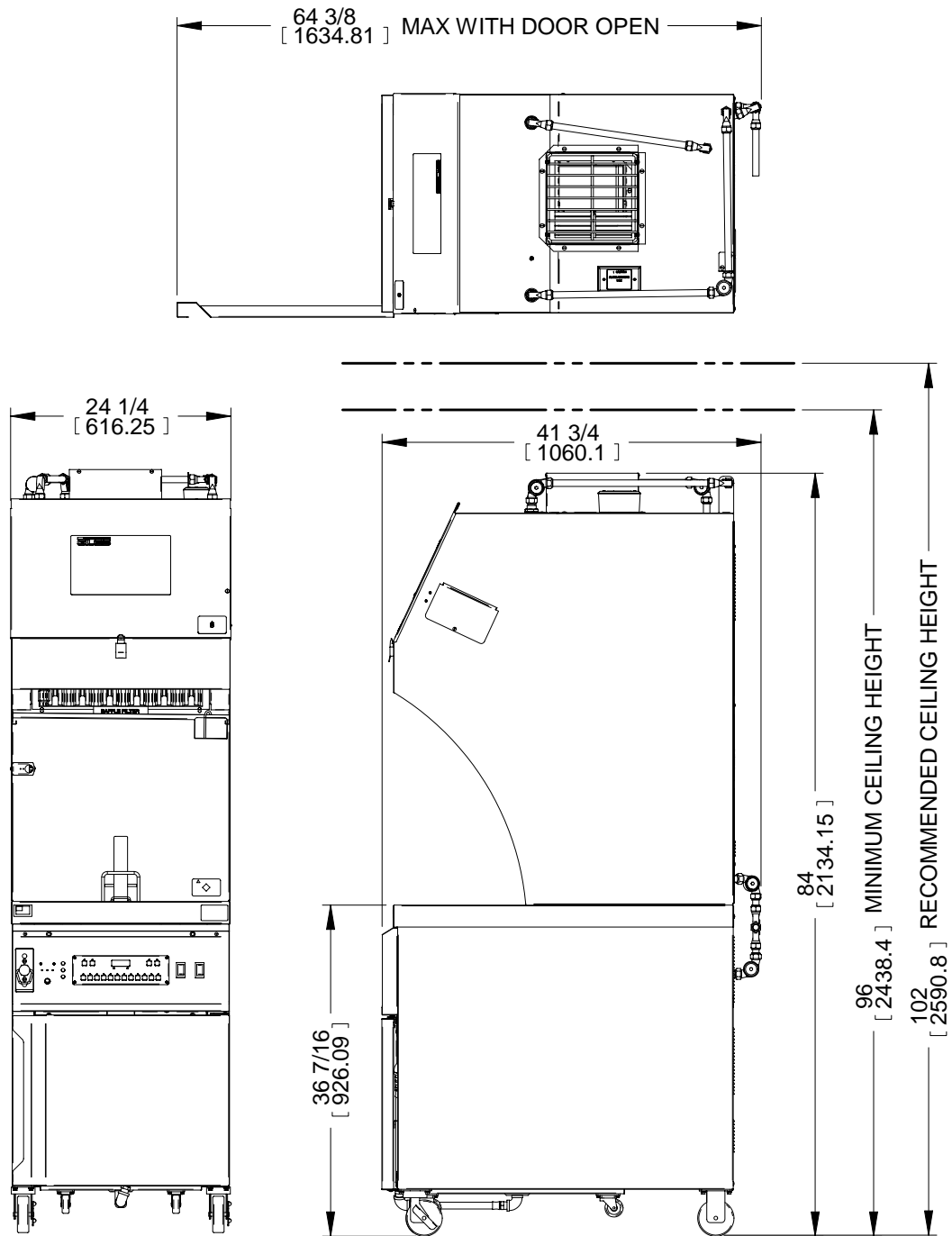

INCHES [MILLIMETERS]

1-4.3. Regulatory Listings

UL (US and Canada)
UL Sanitation
CE

1-4.4. Basket Sizes

Model	Basket Size				Volume	
	Diameter		Height		cubic inch	cubic meter
	in	mm	in	mm		
GEF-400 & GEF-400-VH	12.37	314.19	10.25	260.35	1231.83	0.0201
GEF-560 & GEF-560-VH	14.75	374.65	10.25	260.35	1751.45	0.0287
GEF-720 & GEF-720-VH	14.75	374.65	12.75	323.85	2178.63	0.0357

1-4.5. Cooking Capacity

Model	Liquid Shortening Capacity				Chicken Capacity		
	lb	kg	gallon	liter	lb	kg	piece count
GEF-400 & GEF-400-VH	45	21	5.8	21.9	14	6.3	40
GEF-560 & GEF-560-VH	60	27	7.8	29.5	19	8.6	56
GEF-720 & GEF-720-VH	75	37	9.7	36.7	24	10.8	72

2. Installation

This section provides a summary of the procedures necessary for proper installation of your new Giles equipment, Model GEF-400, GEF-560, GEF-720, GEF-400-VH, GEF-560-VH, GEF-720-VH. To prevent personal injury or equipment damage, please ensure the following steps are taken.

2-01. Location

Note:

- The decibel level of the hood when operating is approximately 65 dB's.

CAUTION

- **DO NOT MODIFY, ALTER OR ADD ATTACHMENTS TO THIS EQUIPMENT**

1. Keep the appliance and surrounding area free and clear from combustible materials. {(3")(7.6cm) for Fryer and (18")(46cm) for Ventless Hood.}
2. Please retain this manual for future reference.
3. Please note wiring diagrams for this appliance are located in the rear of this manual. Ensure the wiring diagram corresponds with the model being operated.
4. Please ensure this appliance is electrically grounded in accordance with local codes, or in the absence of local codes, with the National Electrical Code, ANSI/NFPA NO. 70-1999.
5. Please provide adequate room for servicing and proper operation of this appliance. Also, provide adequate ventilation in the operating area where necessary.
6. Always consult with an electrician or other qualified individual prior to installation.
7. Ensure voltage and amperage supplied to the unit are as specified on the fryer's rating plate.
8. Make sure this unit is in a secure position and will not move. Locking casters are supplied on this unit—use them!
9. Based on local codes, room size and appliances in use, exhaust ventilation may be required. This often can be accomplished by the installation of an exhaust fan in the room in which the hood is installed. To determine the requirements for your installation, supply the HVAC dealer the following information.
 - a. The Hood exhausts between 510 to 680 cfm of air.
 - b. The average temperature of the air being exhausted from the Hood, after four (4) hours of continuous frying, is approximately 90°F (32°C).
10. This appliance is to be installed, used and maintained in accordance with the Standard for Ventilation Control, and Fire Protection of Commercial Cooking Operations, NFPA 96-1994.

The above steps will help to ensure safe and proper installation of your fryer. If you have any questions concerning these procedures, contact your local Giles distributor or other qualified service person.

2-02. Unpacking

Your Giles Fryer may arrive enclosed by a wooden crate. The Fryer is secured to a wooden platform by means of high-tensile strength strapping.

CAUTION

- The Ventless Hood must remain in the upright (vertical) position.
- Exercise care when lifting or moving the unit.
- Exercise care when removing the wooden crate from around the unit.
- Failure to comply with these **CAUTION** notices may result in minor or moderate injury, equipment/property damage, and void the warranty.

Note:

- If crate is damaged, immediately inspect the unit and notify the carrier of any damage to the unit.

1. Carefully cut and remove the plastic shipping wrap and the strapping mentioned above.
2. Use pliers to loosen wire hooks which secure the wooden crate around the fryer. Remove the wooden crate.
3. Carefully remove the fryer from the shipping platform. Your new fryer is extremely heavy, GEF-400, GEF-560, GEF-720 are 332 lbs (151 kg) and GEF-400-VH, GEF-560-VH, GEF-720-VH are 554lbs (252 kg), great care should be taken in lifting or moving the unit to prevent personal injury or equipment damage.

Installation

Model: GEF-400, GEF-560, GEF-720 &
GEF-400-VH, GEF-560-VH, GEF-720-VH

2-03. Electrical Requirements

⚠ CAUTION

- Fryers must be adequately and properly grounded. Improper grounding may result in electrical shock. Always refer to your local electrical code to ensure proper grounding of this or any other electrical equipment. Always consult with an electrician or other qualified service person to ensure breakers and wiring are of sufficient rating and gauge for the equipment being operated.
- Giles Electric Fryers are available from the factory in the voltage and phase listed below. Check the rating plate on the front of the fryer to determine the correct power supply.

Table 2-03. Electrical Requirements (Continued on next page)

Model	Voltage	Hz	Phase	Watts	AMPS			Breaker Required
					L1	L2	L3	
GEF-400	208	60	1	10,000	48	48	---	60
GEF-400	208	60	3	10,000	29	29	29	40
GEF-400	240	60	1	10,000	42	42	---	50
GEF-400	240	60	3	10,000	25	25	25	35
GEF-400	380	50	3	9,585	14	14	14	20
GEF-400	415	50	3	10,000	14	14	14	20
GEF-400-VH	208	60	1	10,400	50	50	---	60
GEF-400-VH	208	60	3	10,400	30	30	30	40
GEF-400-VH	240	60	1	10,400	44	44	---	60
GEF-400-VH	240	60	3	10,400	26	26	26	35
GEF-400-VH	380	50	3	9,970	15	15	15	20
GEF-400-VH	415	50	3	10,400	15	15	15	20

2-03. Electrical Requirements (Continued)

Model	Voltage	Hz	Phase	Watts	AMPS			Breaker Required
					L1	L2	L3	
GEF-560	208	60	1	15,000	72	72	---	100
GEF-560	208	60	3	15,000	43	43	43	60
GEF-560	240	60	1	15,000	63	63	---	80
GEF-560	240	60	3	15,000	38	38	38	50
GEF-560	380	50	3	14,375	21	21	21	30
GEF-560	415	50	3	15,000	21	21	21	30
GEF-560-VH	208	60	1	15,400	74	74	---	100
GEF-560-VH	208	60	3	15,400	44	44	44	60
GEF-560-VH	240	60	1	15,400	64	64	---	80
GEF-560-VH	240	60	3	15,400	38	38	38	50
GEF-560-VH	380	50	3	14,770	21	21	21	30
GEF-560-VH	415	50	3	15,400	22	22	22	30
GEF-720	208	60	3	20,000	58	58	58	80
GEF-720	240	60	3	20,000	49	49	49	60
GEF-720	480	60	3	20,000	25	25	25	35
GEF-720	380	50	3	19,166	28	28	28	35
GEF-720	415	50	3	20,000	28	28	28	35
GEF-720-VH	208	60	3	20,400	58	58	58	80
GEF-720-VH	240	60	3	20,400	50	50	50	60
GEF-720-VH	480	60	3	20,400	25	25	25	40
GEF-720-VH	380	50	3	19,600	28	28	28	35
GEF-720-VH	415	50	3	20,400	28	28	28	35

Installation

**Model: GEF-400, GEF-560, GEF-720 &
GEF-400-VH, GEF-560-VH, GEF-720-VH**

2-04. Electrical Connections

1. Install appropriate Circuit Breaker in Main Breaker Box. See Table 2-03.
2. Connect 1-1/4" Flexible Conduit from Main Breaker Box to Fryer. Allow enough Conduit so Fryer can be moved from the wall for cleaning and servicing. See Figure 2-04.1.
3. Open Fryer Door and remove Service Box Cover. See Figure 2-04.2.
4. Route appropriate size Power Wires from the Circuit Breaker to the Fryer.
5. Connect the Power Wires to the appropriate Terminal Blocks located in the Service Box. See Figure 2-04.2.
6. Reinstall Service Box Cover and close the Fryer Door.

2-04.1 Routing conduit

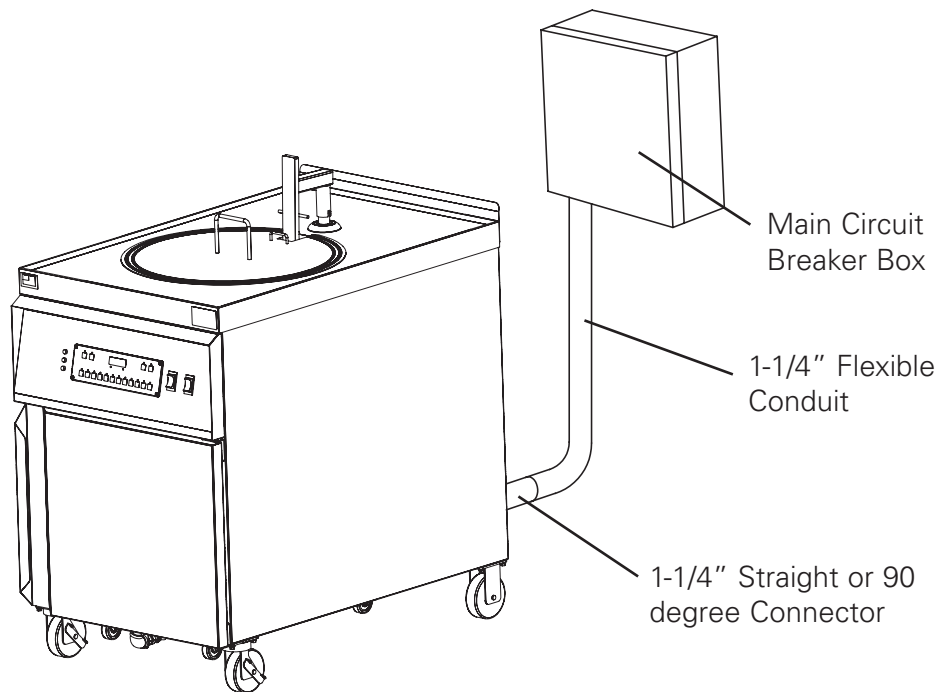

2-04.2 Service Box Connections

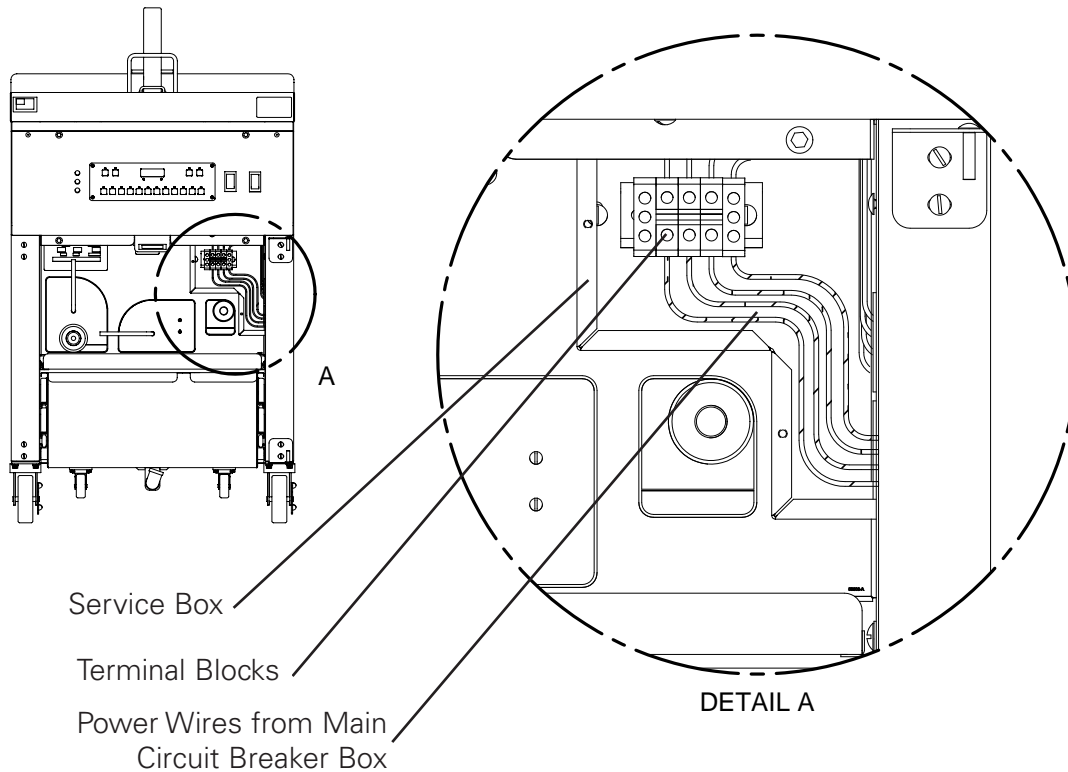

2-05. Ventilation of Non-Ventless Fryer

Note:

- Guidelines for proper ventilation system requirements may differ from location to location. Always consult with local authorities to ensure compliance.

Consult a professional ventilation or heating and air conditioning company for assistance in designing a hood for this unit.

2-06. Ventless Hood Clearances

The GEF Ventless Hood series requires a minimum 12 inches [305 mm] clearance from the top of the exhaust stack to the ceiling, however 18 inches [457 mm] is recommended. This is required to allow the proper air flow through the unit.

Installation

Model: GEF-400, GEF-560, GEF-720 &
GEF-400-VH, GEF-560-VH, GEF-720-VH

2-07. Ventless Hood Fire Suppress System

The fire suppression system used in your Giles Ventless Hood Fryer is an Ansul R-102 Restaurant Fire Suppression System (Standard UL 197 Listed). **Final installation, charging and testing of the system is to be performed by an authorized Ansul distributor in accordance with the system's listing.**

The fire suppression system is designed and UL-listed to provide fire protection for cooking appliances such as fryers. It protects your units, automatically, 24 hours per day. The system contains piping, nozzles (both appliance and plenum), and conduit for routing the fusible link cable through the hood.

2-08. Fusible Link and Gas Cartridge Locations

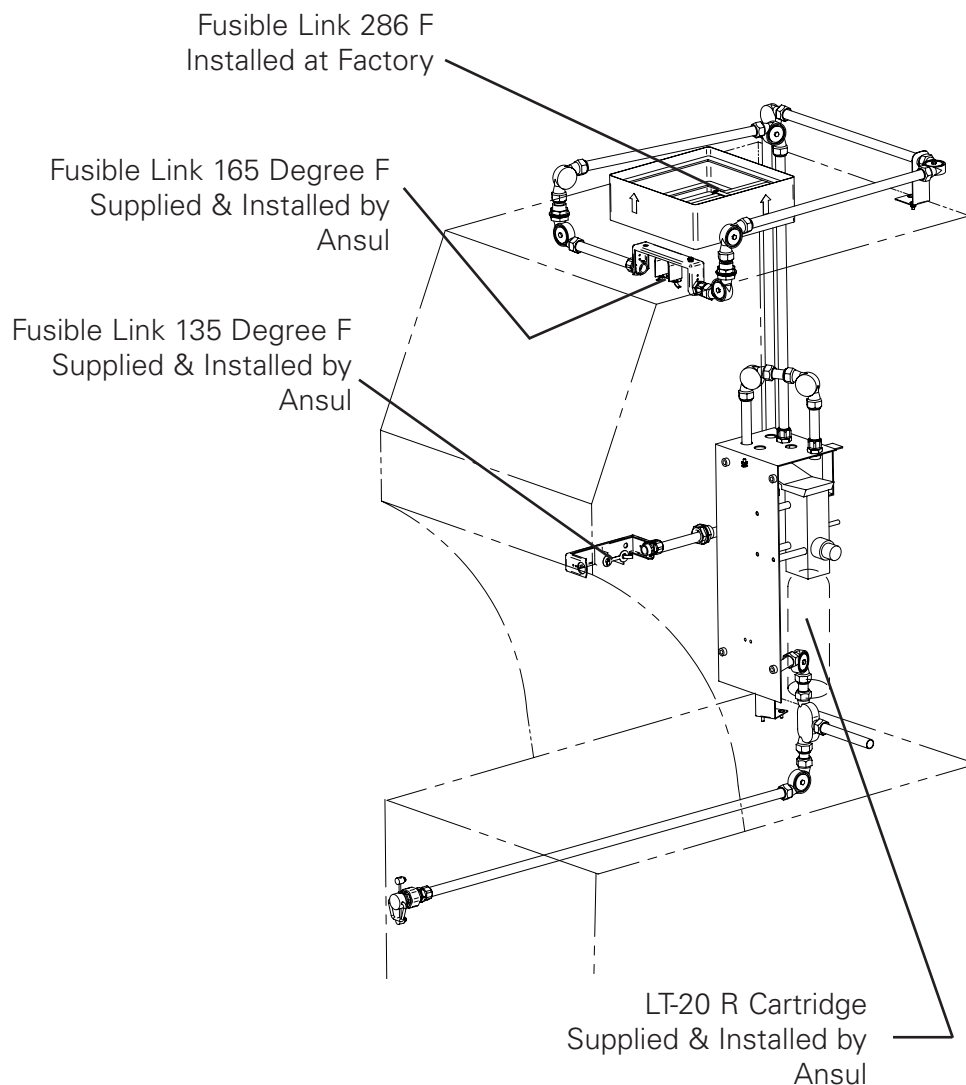

2-09. Fire Extinguisher Nozzle and Tank Locations

All nozzles have been factory installed in the proper operating position. **DO NOT MOVE OR ADJUST.**

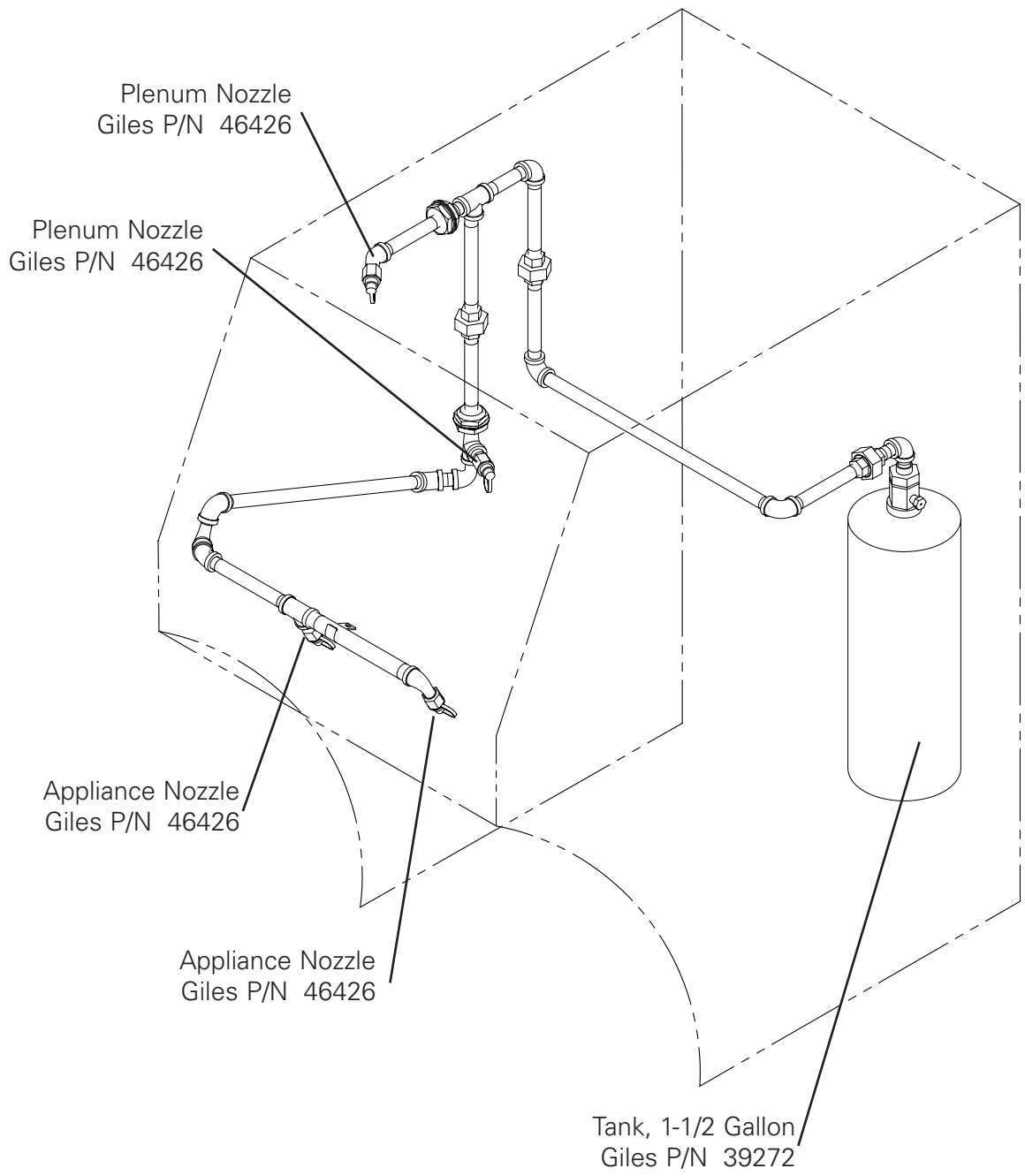

2-10. Fire Alarm Connection

This connection will send a signal the Facility Fire Alarm System that the Hood Fire Extinguisher System has been activated.

Fire Alarm Connection:

1. Remove Cover on Fire Alarm Tie-In Box and run appropriate size conduit and wire from the Box to the Facility Fire Alarm System. Allow enough conduit and wire so the Hood can be accessed for cleaning and servicing.
2. Make appropriate connections.
3. Reinstall Fire Alarm Tie-In Box Cover.

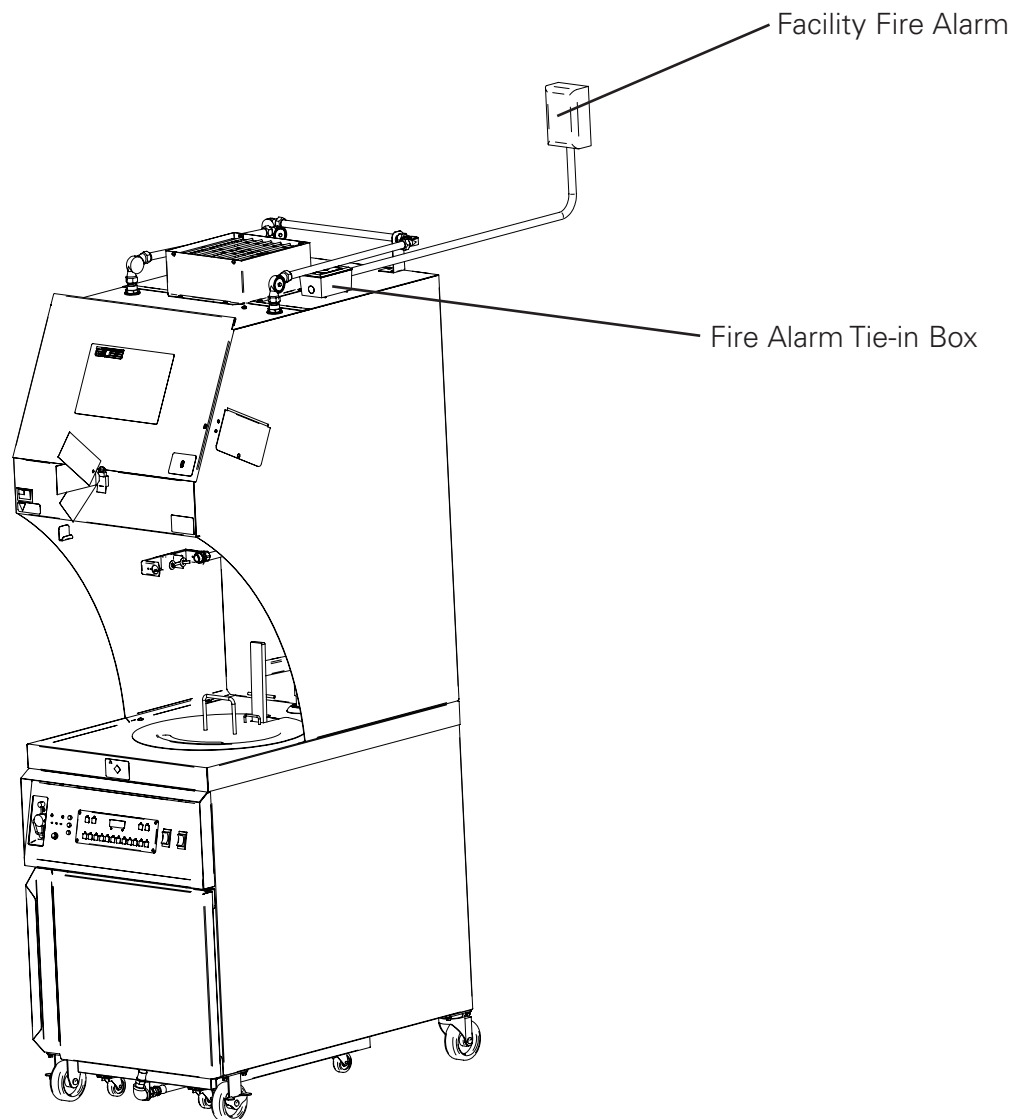

2-11. Changing the Door Swing

In some locations the door swing may need to be reversed to allow for easy access to the lower cabinet area. Please follow this procedure to change the door swing.

1. Disconnect power to the unit.
2. Remove (4) screws **1** on the left-side of the lower cabinet.
3. Remove (4) screws **2** holding the top and bottom hinges to the lower cabinet.
4. Remove the plastic washer **3** from the bottom hinge.
5. Move and rotate the top-right hinge **4** to the bottom left side and fasten to the lower cabinet. Then place the plastic washer **3** on the hinge.
6. Rotate the Cabinet Door and place on the bottom left hinge.
7. Move and rotate the bottom-right hinge **5** to the top left side and fasten to the lower cabinet.
8. Check the door swing for levelness and adjust if needed.
9. Fasten (4) screws to right-side of the lower cabinet.
10. Reconnect power to the unit.
11. Order new Quick Reference Door Label ***6** (Part number 60802) and apply over existing label.

* -Not shown

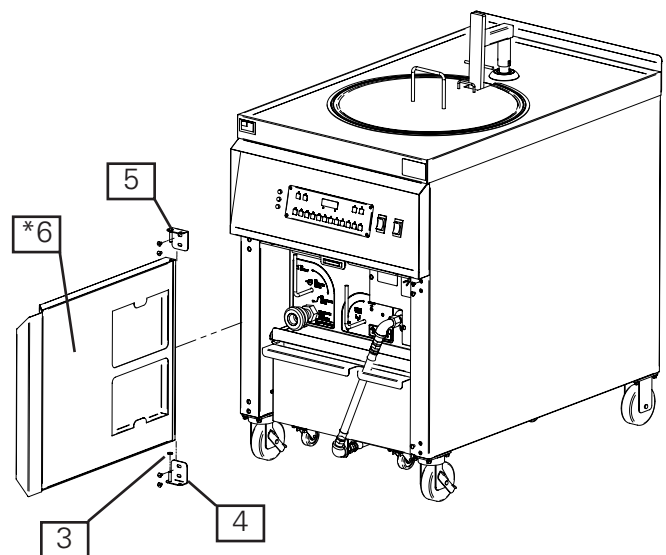
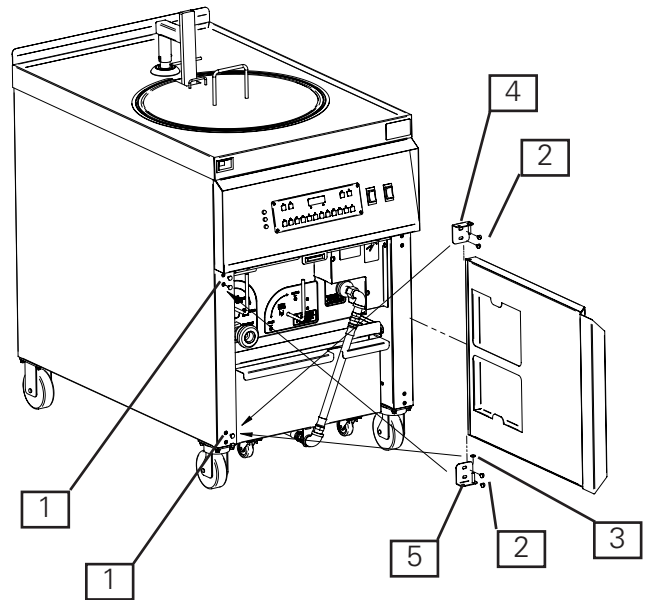

Overview

Model: GEF-400, GEF-560, GEF-720 &
GEF-400-VH, GEF-560-VH, GEF-720-VH

3. Overview

The following section provides a brief overview of the components, functions, and accessories of the Giles Electric Fryer, Model GEF-400, GEF-560, GEF-720, GEF-400-VH, GEF-560-VH and GEF-720-VH. Please review this section carefully before proceeding any further.



3-1. Control Panel

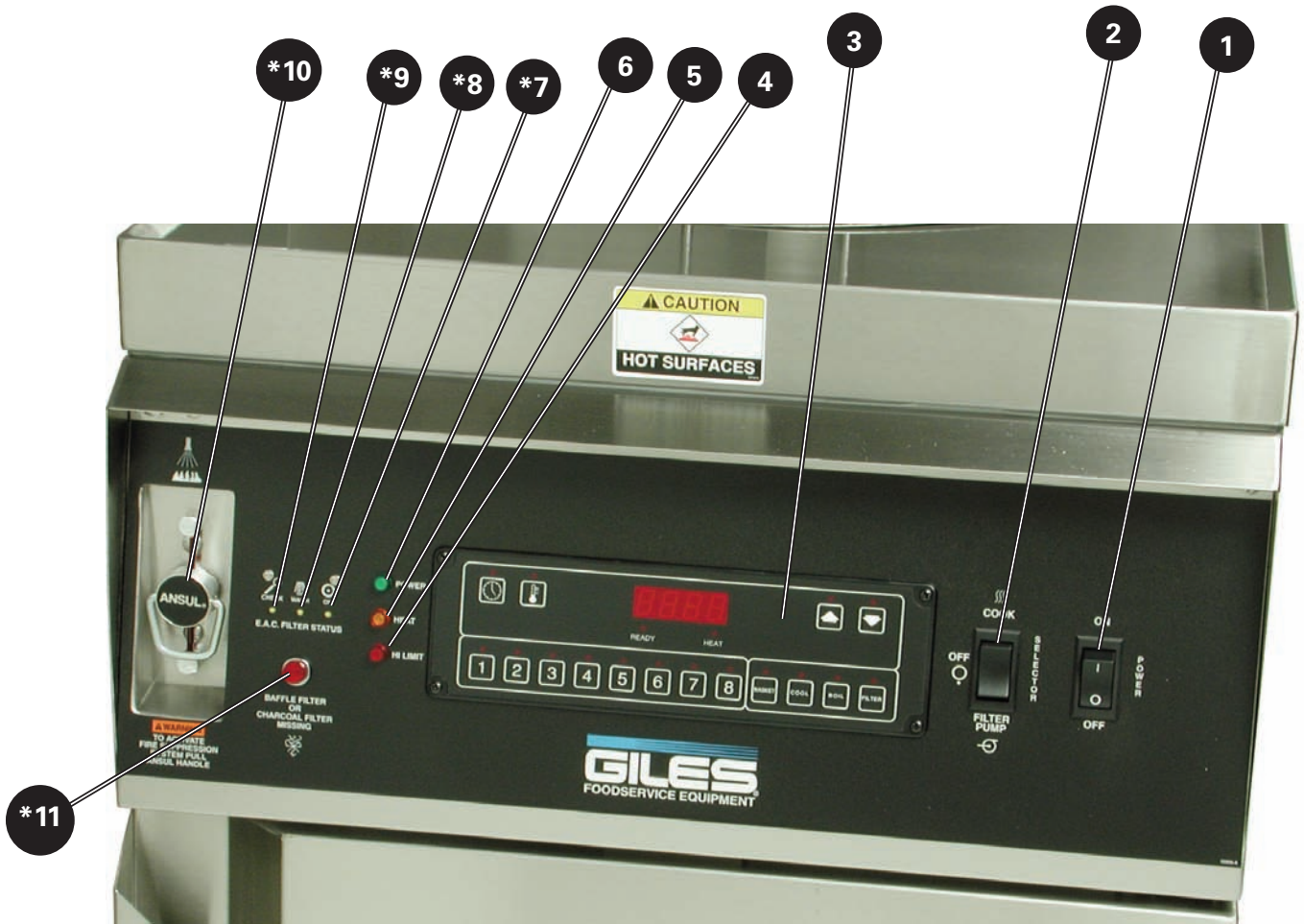

* -Used on Ventless Hood (VH) Models Only

Overview

**Model: GEF-400, GEF-560, GEF-720 &
GEF-400-VH, GEF-560-VH, GEF-720-VH**

3-1. Control Panel

Item	Description	Function
1	Power Switch	The Power Switch is a two-position Switch. Move the switch upward to the "ON" position for operation.
2	Selector Switch	The Selector Switch is a three-position switch which is used to select either the "COOK", "OFF" or "FILTER" mode of operation. The fryer's heating elements will only operate in the "COOK" position. The switch should be placed in the "FILTER" position to filter the shortening which will allow the pump to operate.
3	Controller	The Electronic Controller is used for setting cooking temperatures and times.
4	High-Limit Indicator	The High-Limit Indicator Light is illuminated as a result of power being shut off to the fryer's heating elements by the built-in solid-state control circuit as a safeguard against overheating. Should this light come on during operation, refer to the Troubleshooting Section 7 of this manual. NEVER COOK IN A FRYER WHEN THE HIGH-LIMIT LIGHT IS ON!
5	Heat Indicator Light	The Orange Heat Indicator Light will be on when the fryer's heating elements are operating. When the selected operating temperature is reached, the light will go off.
6	Power Indicator Light	The Green Power Light is on whenever the fryer's Master Power Switch is in the ON position.
*7	"ON" Indicator Light	The "ON" Indicator Light is on when the Electronic Air Cleaner (EAC) power supply is on.
*8	"Wash" Indicator Light	The "Wash" Indicator Light is on when the EAC becomes excessively dirty. Do not use the wash light as a signal for routine cleaning of the EAC, doing so will significantly decrease the life of the charcoal filter. Clean the EAC daily for best performance and extended charcoal filter life.
*9	"Check" Indicator Light	The "Check" Indicator Light is on when the EAC becomes shorted. (EAC needs cleaning or repair).
*10	Fire Extinguisher Pull Handle	Pull this handle if an accidental fire should occur in the cooking vat. This will actuate the fire suppression system.
*11	"Filter Missing" Light	The "Filter Missing" Light is on when the Grease Baffle Filter or the Charcoal Filter are not properly positioned.
*12	"PUSH to START" Button (Not Shown)	After the Power Switch is in the "ON" position, push and hold down "PUSH to START" Button for 5 seconds. (Used only in units with ILS (Interlocking Start)).

3-2. Lower Cabinet Area

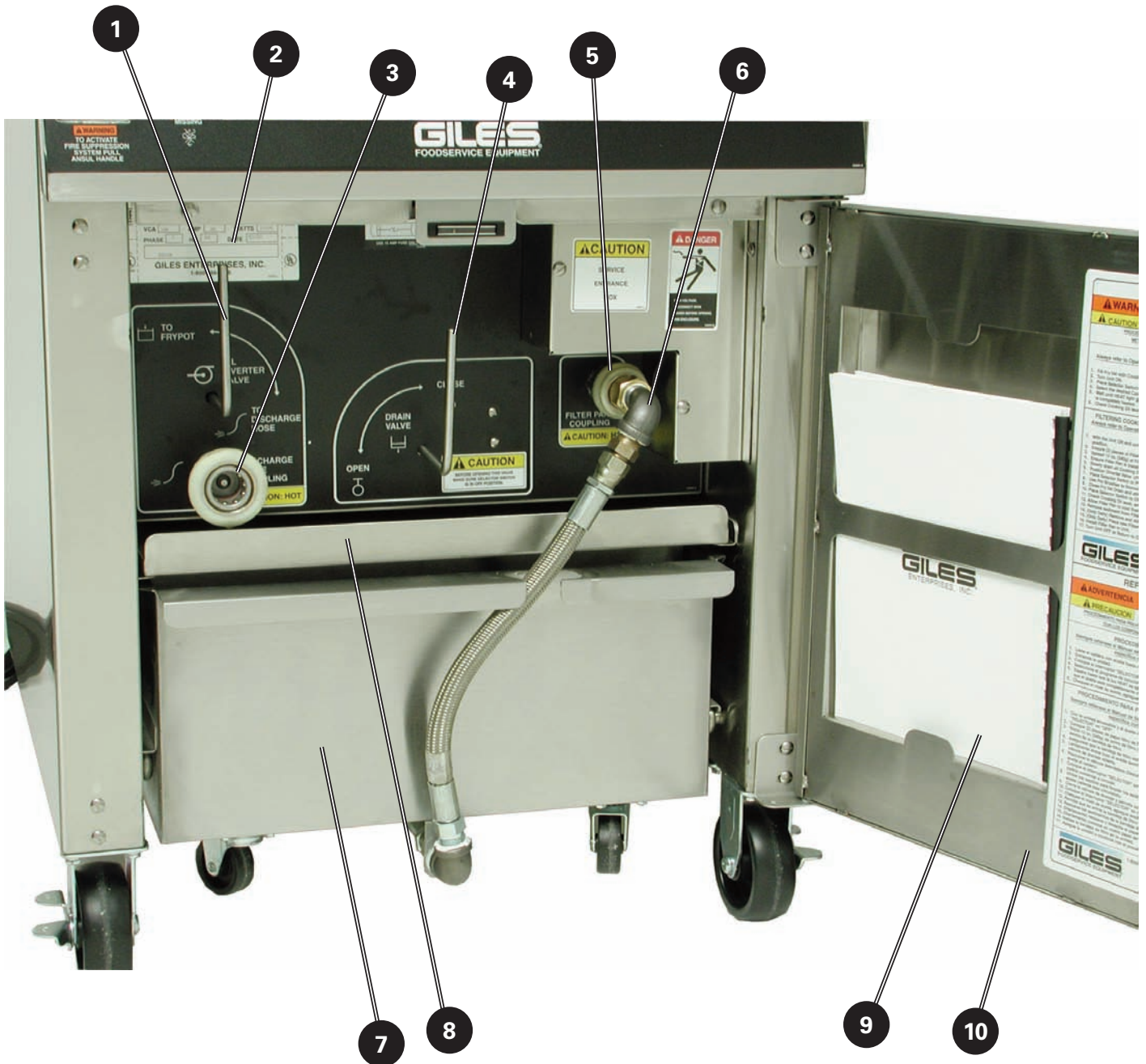

Overview

**Model: GEF-400, GEF-560, GEF-720 &
GEF-400-VH, GEF-560-VH, GEF-720-VH**

3-2. Lower Cabinet Area

Item	Description	Function
1	Diverter Valve Handle	Used to divert the cooking oil to the cooking vat or to the cooking oil discharge wand.
2	Serial Plate	Used to identify the serial number, voltage, and phase of the unit.
3	Quick Disconnect for Oil Discharge Wand	Used in conjunction with the oil discharge wand to remove oil from the fryer.
4	Drain Valve Handle	Used to drain the cooking vat. Always ensure the valve is closed prior to adding cooking oil or boil out solution. Your fryer will not heat if this drain valve is not completely closed.
5	Quick Disconnect for Filter Pan Hose	Used to connect the Filter Pan Quick Disconnect hose to the fryer's oil filtration system.
6	Filter Pan Quick Disconnect Hose	See Section 3-3.
7	Filter Pan	See Section 3-3.
8	Filter Pan Cover	Used to protect the cooking oil.
9	Operation Manual Holder	Used as a convenient place to store the unit's Operation Manual.
10	Cabinet Door	Used to access all lower cabinet functions. Cabinet Door is field reversible, if needed.

3-3. Filter Pan Assembly

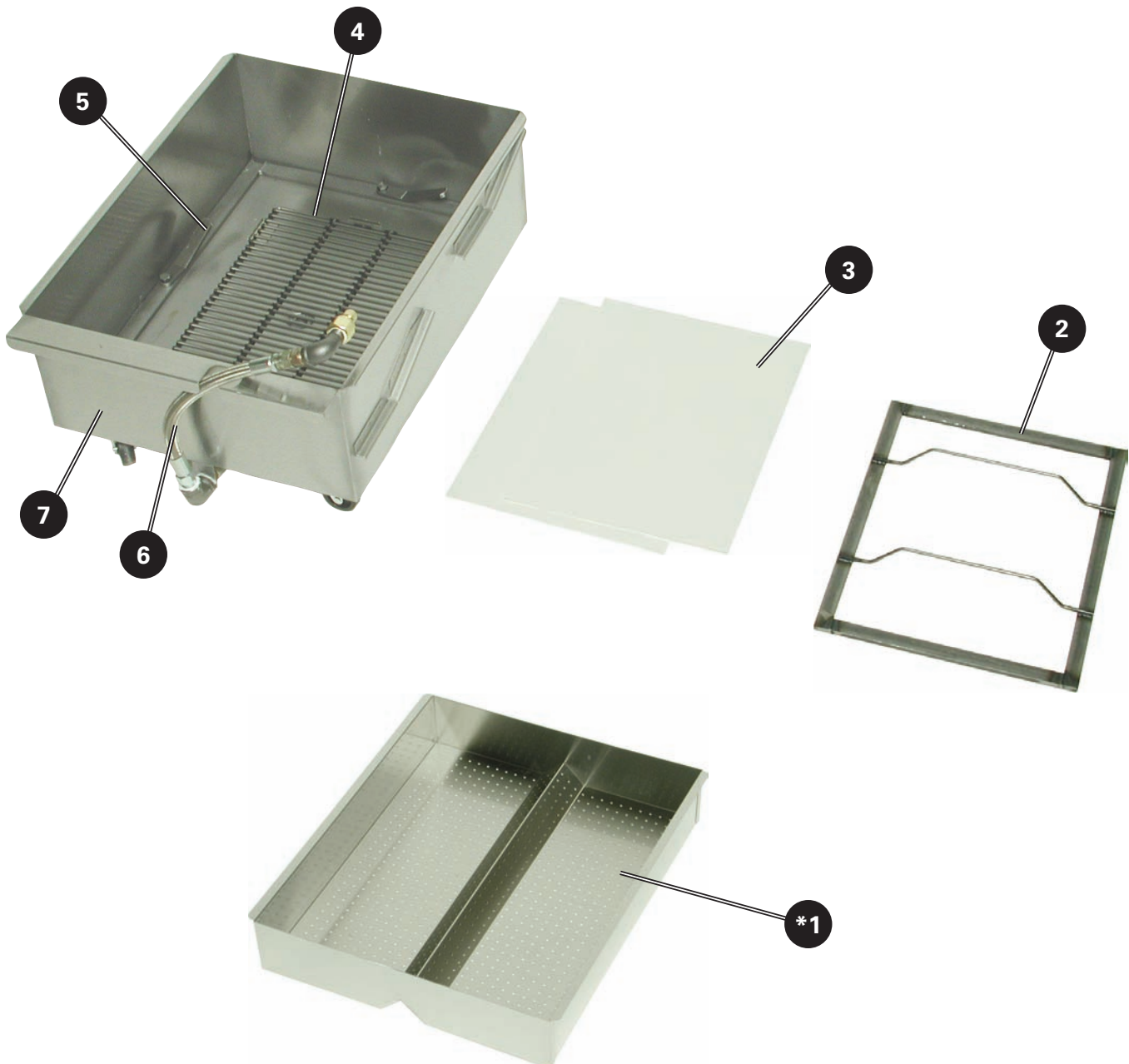

* -Not included, Accessory Item

Overview

Model: GEF-400, GEF-560, GEF-720 &
GEF-400-VH, GEF-560-VH, GEF-720-VH

3-3. Filter Pan Assembly

Item	Description	Function
*1	Crumb Screen	Used to filter bigger particles of sediment from the cooking oil.
2	Hold Down Frame	Used to tightly hold down the filter paper.
3	(2) Filter Paper	Used to filter finer particles of sediment from the cooking oil. The system requires (2) pieces to be used.
4	Filter Pan Screen	Used to elevate the filter paper from the bottom of the filter pan to allow proper filtration.
5	(4) Hold Down Lever	Used to tightly hold down the hold down frame on the filter paper.
6	Filter Pan Quick Disconnect Hose	Used to connect to the fryer's oil filtration system. The hose must be disconnected before removing the filter pan
7	Filter Pan	Used to filter cooking oil. The Filter Pan is removable for cleaning and for the changing of the filter paper.

* -Not included, Accessory Item

3-4. Basket and Elevator Assembly



Overview

Model: GEF-400, GEF-560, GEF-720 &
GEF-400-VH, GEF-560-VH, GEF-720-VH

3-4. Basket and Elevator Assembly

Item	Description	Function
1	Basket Cover	Used to cover the product during the cooking cycle. When in place this will prevent hot cooking oil from splashing from the cooking vat.
2	Basket Carrier	Used to hold the basket in the correct position when the basket is lifted or lower by the elevator.
3	Basket	Used for cooking product.
4	Elevator	Used to lower and lift the basket from the cooking vat.

3-5. Ventless Hood (VH)

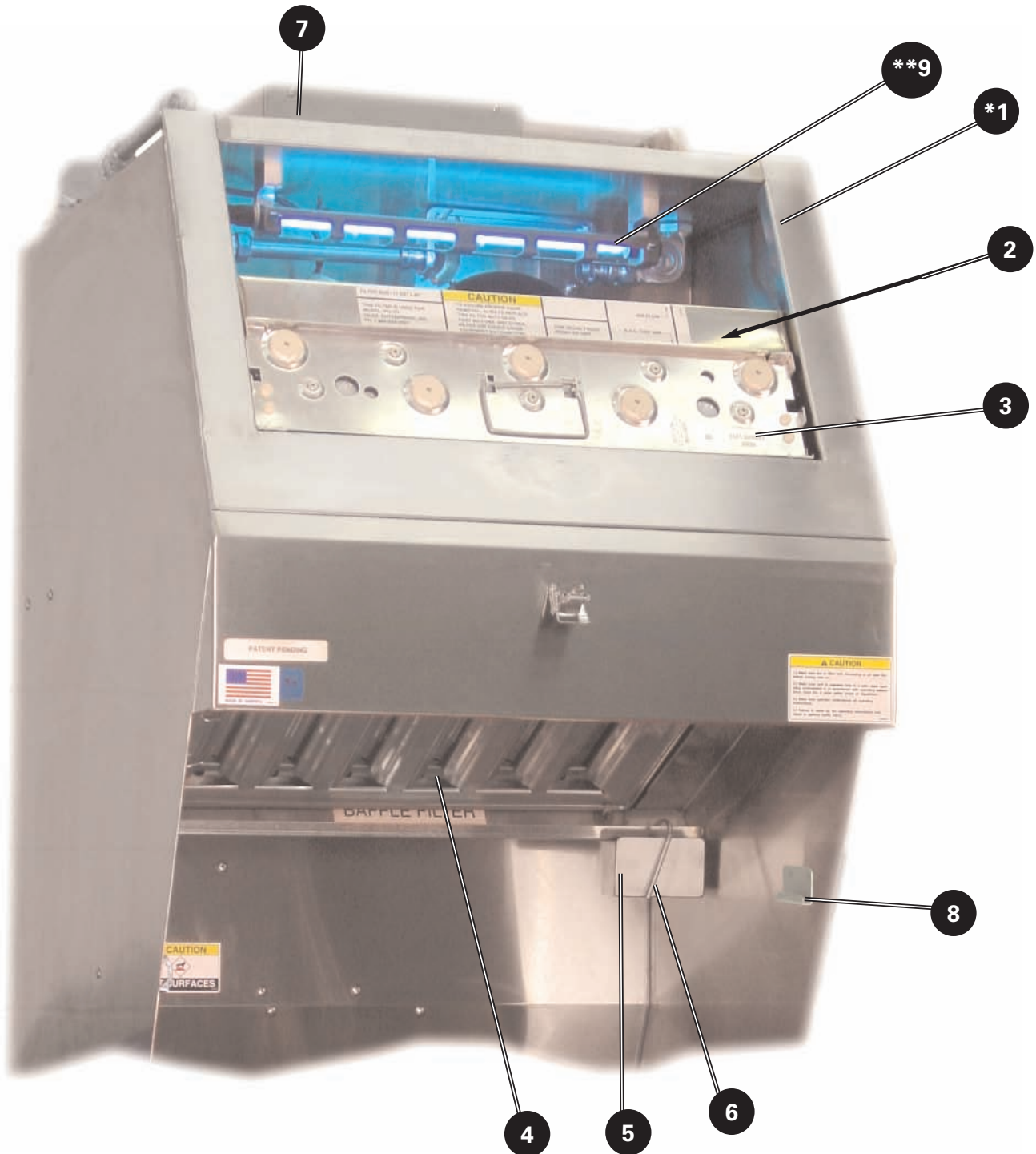

* -Not Shown
** -UV Option Only

Overview

Model: GEF-400, GEF-560, GEF-720 &
GEF-400-VH, GEF-560-VH, GEF-720-VH





3-5. Ventless Hood (VH)

Item	Description	Function
*1	Hood Filter Cover	Used to access the EAC and Charcoal Filters. This cover must be in place and latched for the unit to operate.
2	Charcoal Filter	This Filter helps to remove odors generated during cooking. This Filter should be replaced monthly. NEVER attempt to clean a Charcoal Filter. Keep a spare filter on hand (Giles 30248) for quick change-out when needed!
3	EAC Filter	The EAC Filter is an electrical device which removes grease vapor and smoke generated by the fryer during cooking. Power must be turned OFF to the fryer before removing the EAC for cleaning. The EAC should be cleaned daily.
4	Baffle Filter	The Baffle Filter is the first stage of the grease extraction and air-cleaning system found on these units. It is easily removed for daily cleaning. DO NOT remove the Baffle Filter while the fryer is operating to prevent contact with electrical parts and avoid electrical shock.
5	Grease Drip Cup	Used to hold excess grease from the hood. This cup should be cleaned daily or as needed.
6	Grease Drip Cup Safety Pin	Used to hold the Grease Drip Cup in place and to prevent the cup from accidentally dropping
7	Exhaust Stack	Located on top of the unit. Allow the recommended clearance of 18" or a minimum clearance of 12" between the top of the Exhaust Stack and the ceiling.
8	Basket Cover Hanger	Used as a convenient place to hang the Basket Cover when loading, unloading, or stirring the product. There is one located on the left side and one on the right side of the hood.
**9	Ultra Violet Lamp <i>(optional)</i>	Improves emission cleaning and odor control as well as keeping the unit free from grease build-up, improving fire safety and less maintenance. This lamp should be cleaned monthly and replaced annually

* -Not Shown

** -UV Option Only





3-6. Accessories (Included)

Part	Description/ Part Number	Function
	<p>Kettle Drain Brush P/N 71025</p>	<p>Used for cleaning the Fry Pot.</p>
	<p>Stir Paddle P/N 77775</p>	<p>Used for stirring Hot Oil and Product being cooked.</p>
	<p>Pot Brush P/N 71100</p>	<p>Used for cleaning Fry Pot and Elements.</p>
	<p>Crumb Shovel P/N 30059</p>	<p>Used for removing sediment from the Filter Pan.</p>

Overview

Model: GEF-400, GEF-560, GEF-720 &
GEF-400-VH, GEF-560-VH, GEF-720-VH

3-6. Accessories (Included)

Part	Description/ Part Number	Function
	L-Shaped Brush P/N 73233	Used for cleaning between elements.
	Discharge Wand P/N 33667	Used for removing liquid shortening from unit. Note: DO NOT USE TO WASH DOWN THE COOKING VAT
	Soak Tank P/N 39327	Used for cleaning EAC filter
	UV Lamp P/N 90226	Used for emission control



3-7. Accessories (Not Included)

Part	Description/ Part Number	Function
	<p>Filter Paper P/N 60810</p>	<p>Used to filter the cooking oil.</p>
	<p>Filter Powder P/N 72004</p>	<p>Used to help clean the cooking oil.</p>
	<p>Fryer Boil-Out P/N 72003</p>	<p>Used to help clean the fry pot.</p>

Overview

Model: GEF-400, GEF-560, GEF-720 &
GEF-400-VH, GEF-560-VH, GEF-720-VH

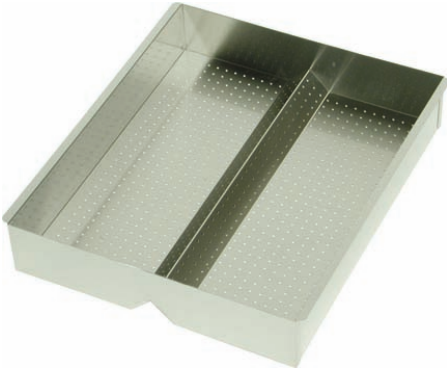
3-7. Accessories (Not Included)

Part	Description/ Part Number	Function
	<p>Filter Pan Crumb Screen P/N 39246</p>	<p>Helps prevent larger particles of breadings from getting into or clogging the filter system.</p>
	<p>Giles Oil Caddy P/N 79187</p>	<p>A portable oil disposal container with a capacity of 80lbs of liquid shortening.</p> <p>Note: For use with filtered, warm oil only. No crumbs or debris.</p>

**Model: GEF-400, GEF-560, GEF-720 &
GEF-400-VH, GEF-560-VH, GEF-720-VH**

Overview



Notes:

Unit Preparation

Model: GEF-400, GEF-560, GEF-720 &
GEF-400-VH, GEF-560-VH, GEF-720-VH

4. Unit Preparation

We at Giles Enterprises, Inc. take pride in the quality of our workmanship. Every effort has been made to ensure that your unit is in good operating condition when you receive it. Each unit must pass a rigorous quality control test prior to shipment. To further ensure optimum operation of your new unit, we recommend a brief operational check-out of your new fryer.

Before attempting to operate the unit, refer to Section 3 to familiarize yourself with the various control functions. Once you have read and fully understand Section 3, please follow the steps below precisely in order to prevent equipment damage or malfunction.

4-1. Settings before testing unit

Please ensure the unit is set to the following settings before proceeding.

1. Power Switch is in the OFF **1** position.
2. Selector Switch is in the OFF **2** position
3. Open the Cabinet Door and remove the Filter Pan.
4. Ensure the Drain Valve Handle is in the CLOSED **3** vertical position.
5. Ensure the Oil Diverter Valve is in the TO FRYER **4** vertical position.
6. Remove Basket Cover, Basket Carrier, and Basket.

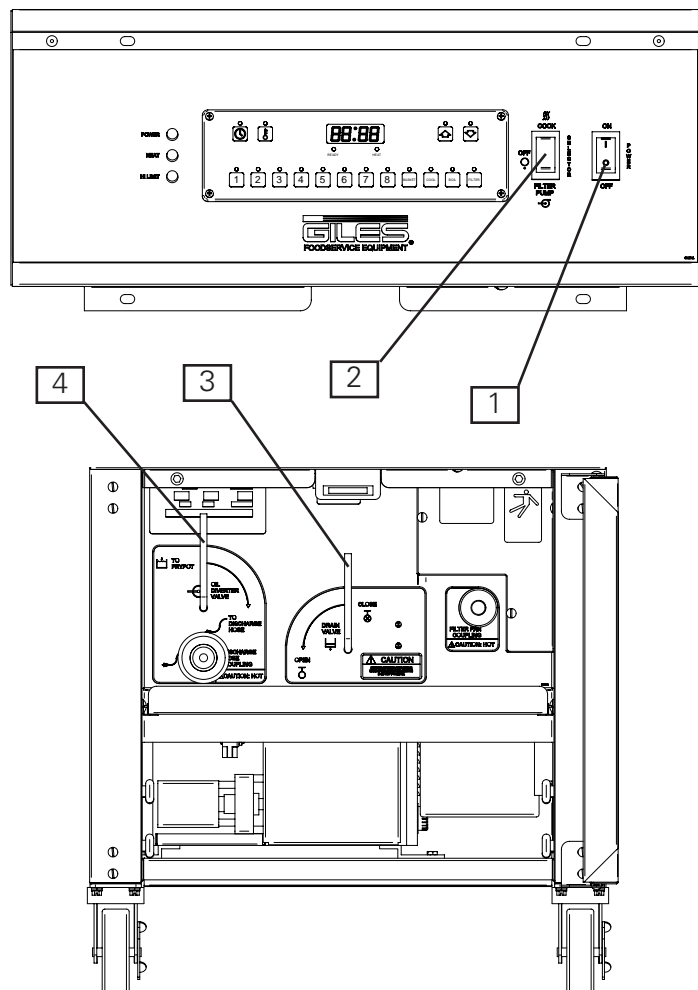

4-2. Power Test

The following test will ensure the unit has power.

1. Follow steps shown in Section 4-1.
2. Ensure the main circuit breaker powering the unit is ON.
3. Press the Power Switch to the ON 1 position. The green POWER light 2 will come on. Please proceed to Section 4-3.

If the POWER does not come on, refer to the Troubleshooting procedure in Section 8-1.

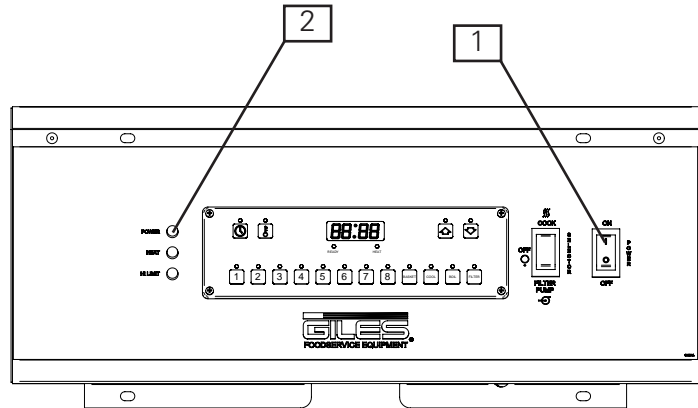

4-3. Heating Element Test

The following test will ensure the Heating Element is being powered.

CAUTION DO NOT touch the Heating Elements. The Heating Elements are very hot and skin contact with the Heating Elements may result in severe burns.

1. Follow steps shown in Section 4-1.
2. Ensure Power Switch is in the OFF position.
3. Wipe the Heating Element 1 with a sponge wet with water.
4. Press the Power Switch to the ON 2 position.
5. Wait until Program 1 3 illuminates on the Controller.
6. Press the Selector Switch to the COOK 4 position. Leave in the COOK position **NO MORE THAN 10 SECONDS.**
7. Press the Selector Switch to the OFF 5 position.
8. The wet element should quickly dry within 15 seconds. Proceed to Section 4-4.

If the Heating Element does not dry within 15-30 seconds, refer to the Troubleshooting procedure in Section 8-1.

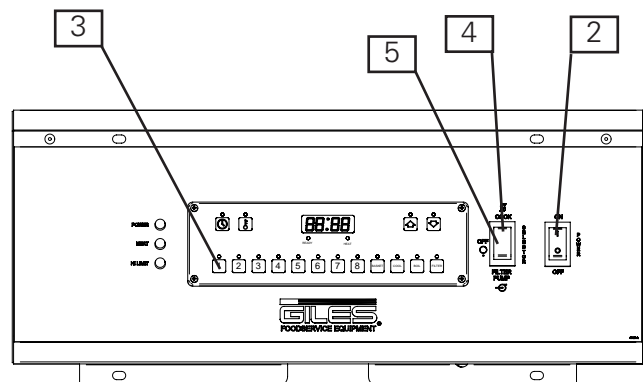
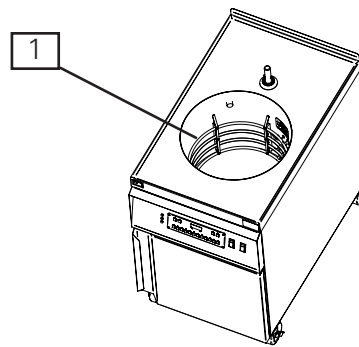

Unit Preparation

Model: GEF-400, GEF-560, GEF-720 &
GEF-400-VH, GEF-560-VH, GEF-720-VH

4-4. Filter Pump Test

The following test will ensure the Filter Pump is operation correctly.

1. Follow steps shown in Section 4-1.
2. Press the Power Switch to the ON **1** position.
3. Open Cabinet Door.
4. Place the palm of your hand over the Quick Disconnect **2** for the Filter Pan Hose.
5. Briefly press the Selector Switch to the PUMP **3** position then press the Selector Switch to the OFF **4** position. If suction is felt on the palm, the pump is operating correctly. Proceed to Section 4-5.

If no suction is felt, refer to the Troubleshooting procedure in Section 8-2.

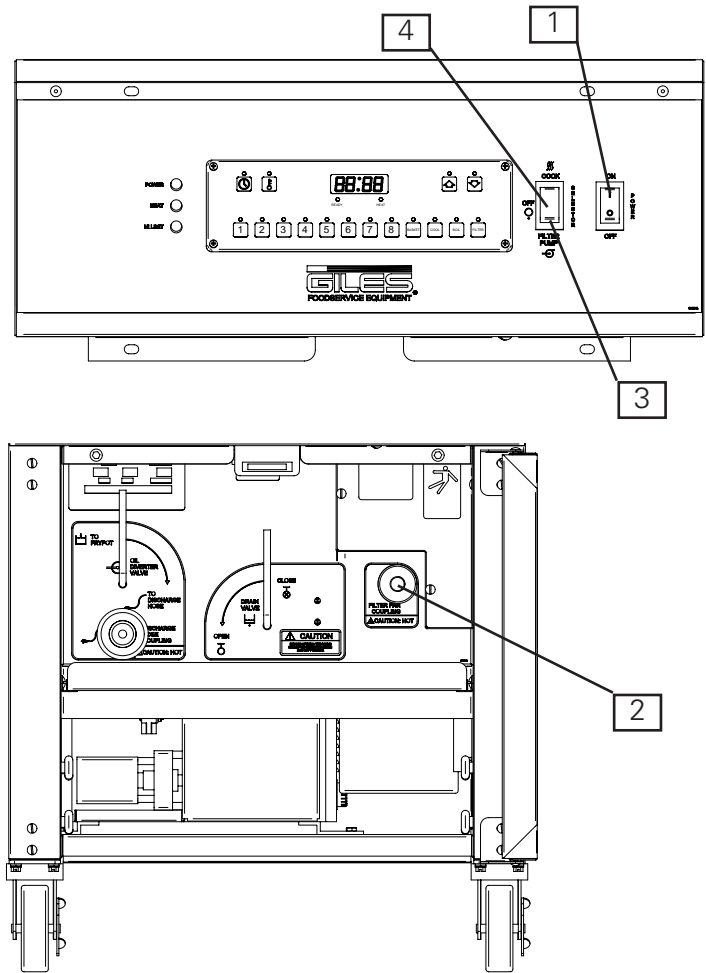

4-5. Perform Boil Out Procedure

Perform a Boil Out Procedure to remove any particles or debris that may have been left due to shipping. Follow Section 6-1 Boil Out Procedure. After performing the Boil Out Procedure proceed to Section 4-6.

4-6. Clean Filter Pan

Thoroughly clean the Filter Pan to remove any particles or debris that may have been left due to shipping. Follow Section 6-2 Cleaning the Filter Pan and replacing Filter Paper after Boil Out.

The fryer's preparation is now complete. Please proceed to the Operation Section.

**Model: GEF-400, GEF-560, GEF-720 &
GEF-400-VH, GEF-560-VH, GEF-720-VH**

Unit Preparation



Notes:

5. Fryer Operation

This section describes how to operate the Giles Electric Fryer, Model GEF-400, GEF-560, GEF-720, GEF-400-VH, GEF-560-VH and GEF-720-VH.

DANGER

- Turn off the unit and turn off the fryer's circuit breaker in the main circuit breaker box before cleaning or performing maintenance.
- **DO NOT** hose down the GEF-400, GEF-560, GEF-720, GEF-400-VH, GEF-560-VH and GEF-720-VH interior or exterior with water.
- Failure to comply with these **DANGER** notices will result in death or serious injury, equipment/property damage, and void the warranty.

CAUTION

- Ensure the fry kettle is positioned in a secure, safe location with the casters in the locked position.
- Consult an electrician to ensure all electrical specifications have been met and the unit is properly grounded. The wiring diagrams contained in this manual should aid your electrician in the installation of your fryer.
- Due to the high temperature of cooking oil in your fryer during cooking, it is extremely important the user exercise caution in operation this equipment to avoid personal injury.

5-1. Cooking Controller.

The following section describes the functions, features and programming of the Cooking Controller

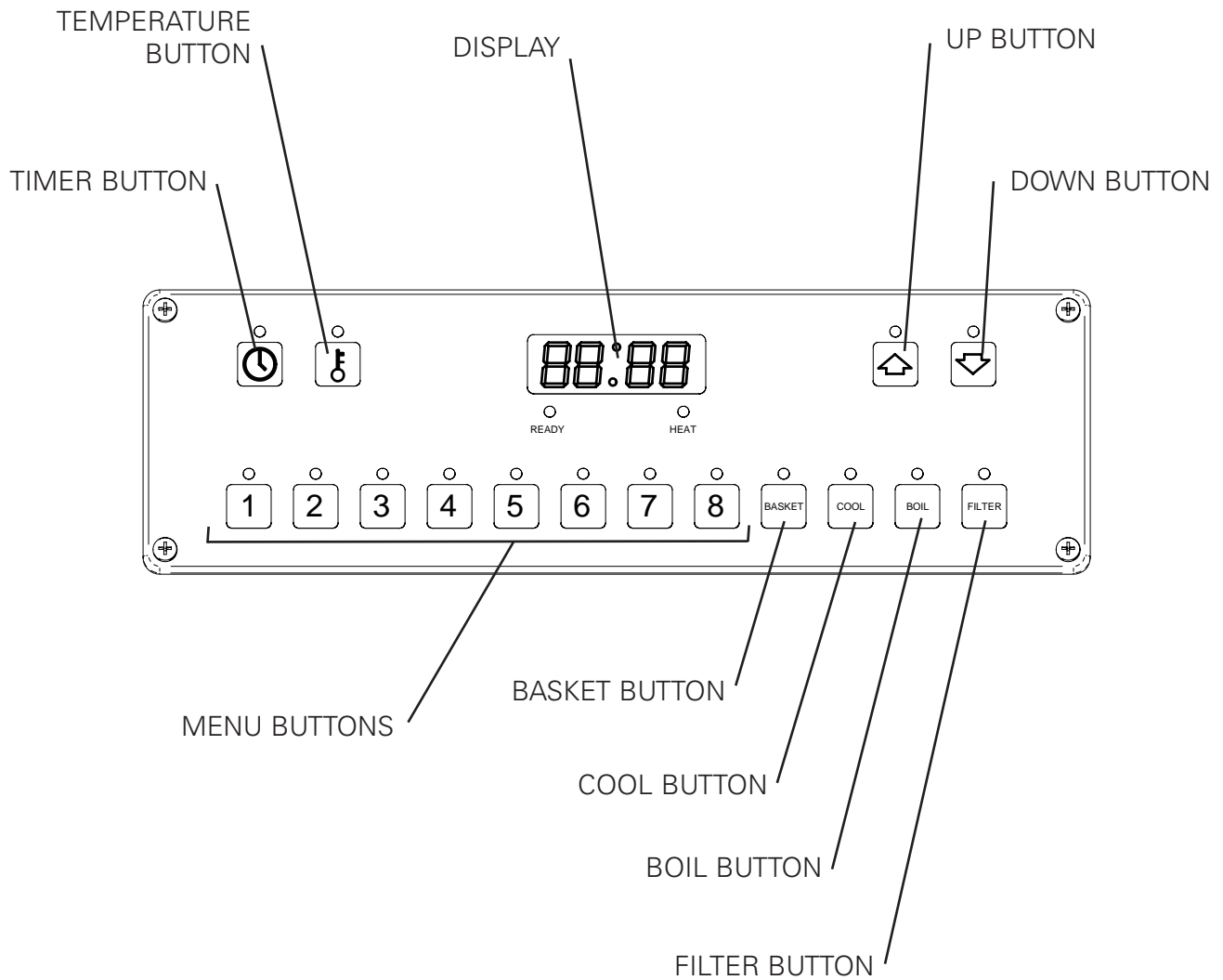

Fryer Operation

Model: GEF-400, GEF-560, GEF-720 &
GEF-400-VH, GEF-560-VH, GEF-720-VH

5-1.1. Button and Function



Used to set and display cooking time.



Used to set and display cooking temperature.



Used to set and recall cooking cycles.



Used to increase cooking time and temperature. Also used to raise the cook basket.



Used to decrease cooking time and temperature. Also used to lower the cook basket.



Used to raise and lower the cook basket. See Section 5-1.6.



Used to place unit in the cool mode. See Section 5-1.8.



Used to place the unit in the boil out mode. Please see Boil Out Procedure, Section 6-1.



Used to end the liquid shortening filtering mode. Please see Filtering Liquid Shortening, Section 5-3.

5-1.2. Programming a Cooking Temperature

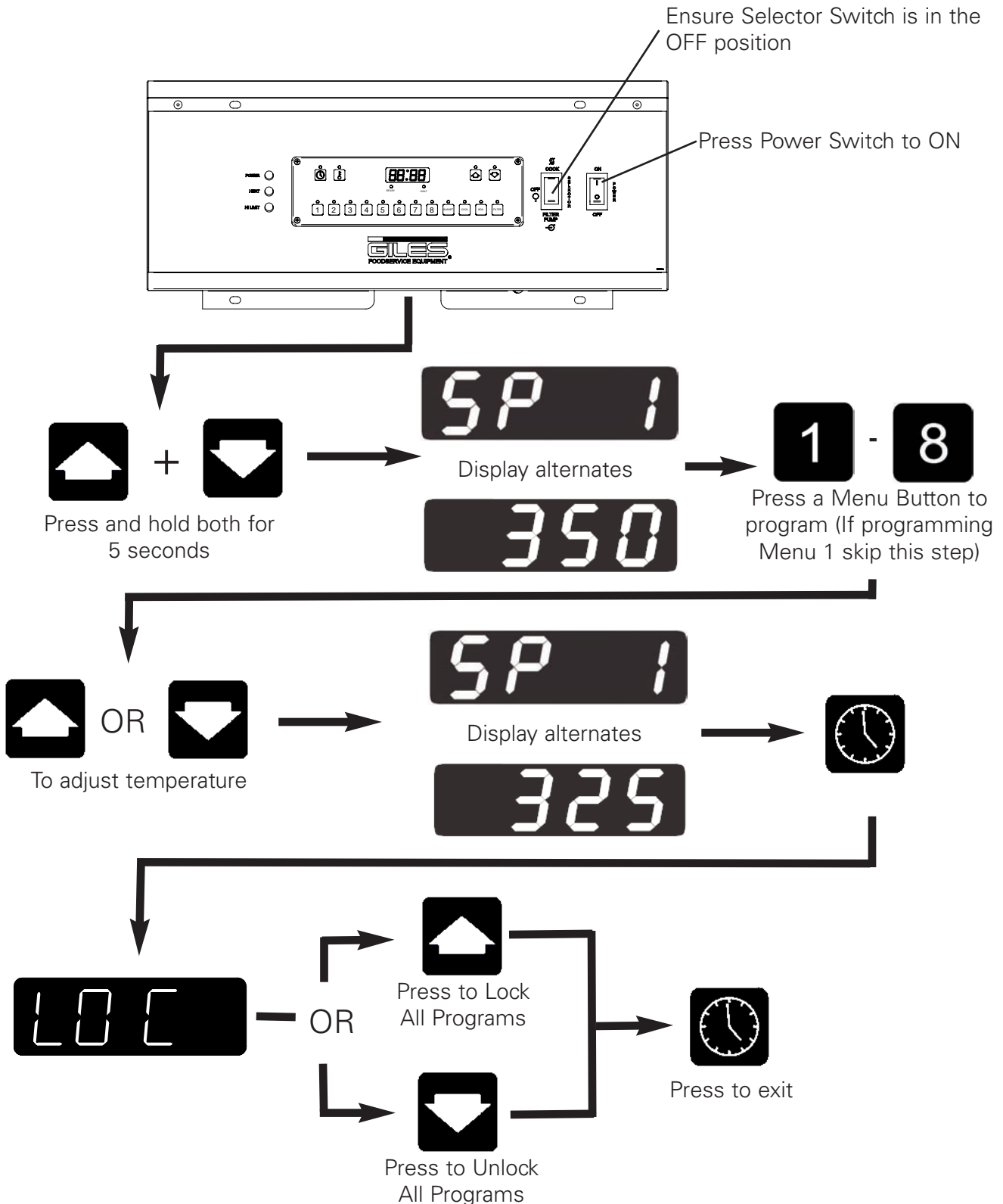

Fryer Operation

Model: GEF-400, GEF-560, GEF-720 &
GEF-400-VH, GEF-560-VH, GEF-720-VH

5-1.3. Programming a Cooking Time

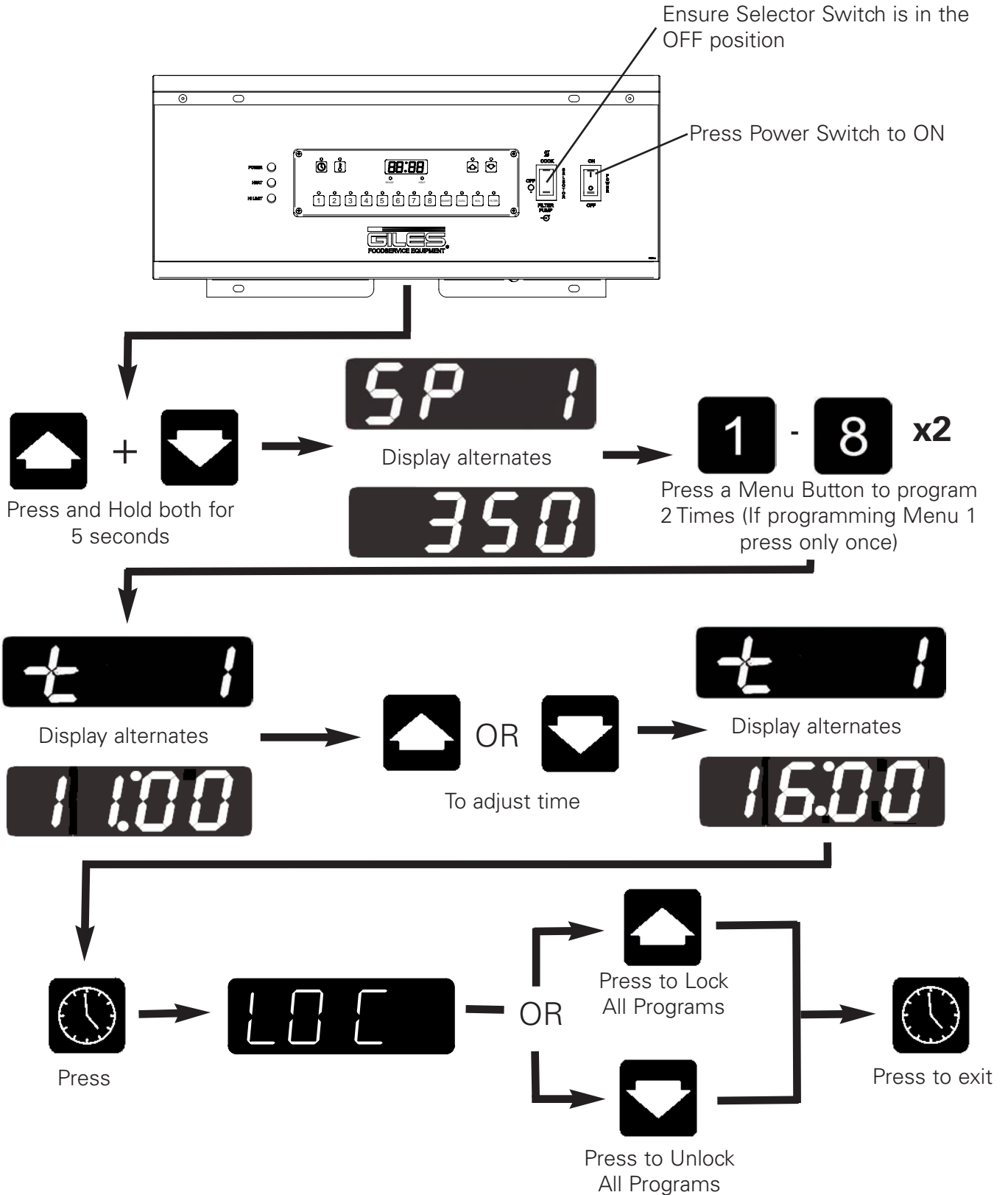

5-1.4. Start a cooking cycle



Press the desired cooking cycle menu button, the cooking cycle will begin.

5-1.5. Cancel the current cooking cycle



Press the current cooking cycle menu button.

5-1.6. Displaying the current temperature of the liquid shortening



Press the current cooking cycle menu button to return.

Press and Hold for 5 seconds

5-1.7. Lowering and raising the cooking basket

Note: The cooking basket cannot be lowered or raised during a cooking cycle, the cooking cycle must be cancelled. See Section 5-1.5.



Press to put controller in the basket mode.

Press to raise cooking basket.

Press to lower the cooking basket.

5-1.8. Cool Mode

The Cool Mode is used to lower and maintain the liquid shortening temperature to 275°F (135°C). This is useful when you are not cooking on the unit but want the unit in a stand by mode. It will conserve energy and extend the life of the liquid shortening.



After a cooking cycle is complete press to place the unit in the cool mode. Press again to cancel the Cool Mode and resume previous cooking cycle temperature.

Fryer Operation

Model: GEF-400, GEF-560, GEF-720 &
GEF-400-VH, GEF-560-VH, GEF-720-VH

5-2. Cooking Procedure

This section describes the cooking process for the unit.

1. Raise and remove the Cooking Basket. See Section 5-1.7.

2. Ensure the Power Switch is in the OFF **1** position.

3. Ensure the Selector Switch is in the OFF **2** position.

4. Ensure the Drain Valve is in the CLOSED **3** vertical position.

5. Fill the Fry Pot with liquid shortening to only the ADD **4** level. The Fry Pot is filled to this level due to the expanding of liquid shortening after it is heated.

6. Press the Power Switch to the ON **5** position. The Power Light **6** will come on

7. Press desired Menu Button **7**.

8. Press the Selector Switch to the COOK **8** position. The Heat Light **9** will come on.

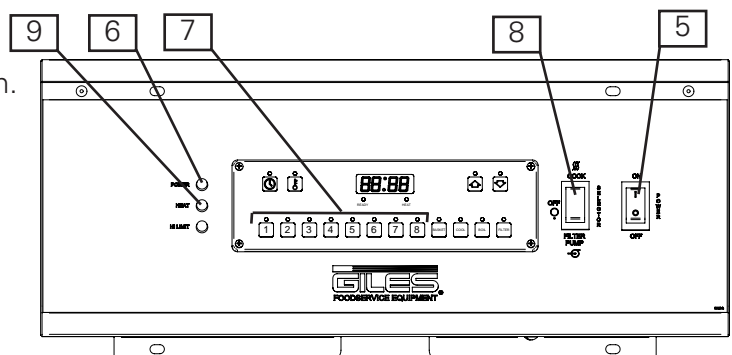
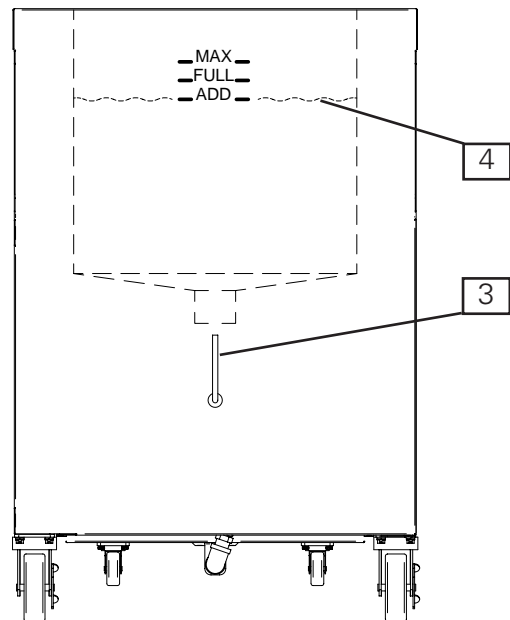
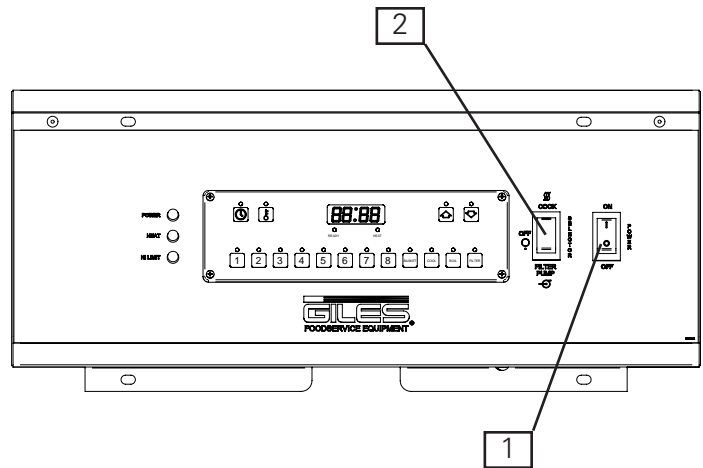

5-2. Cooking Procedure (Continued)

- Using the supplied Stir Paddle, occasionally stir the Liquid Shortening while it is preheating. This will remove cold areas in the Liquid Shortening and allow for more even cooking of the product.
- Once the Liquid Shortening is preheated to the set temperature the Heat Light **10** will go out.

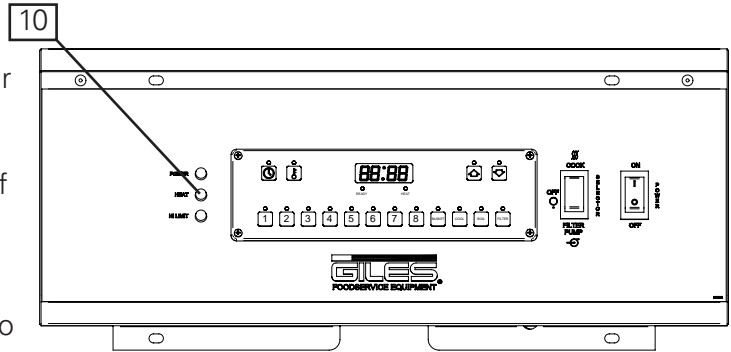

- Check the Liquid Shortening level, it should now be at the FULL **11** Level . Add Liquid Shortening if needed.

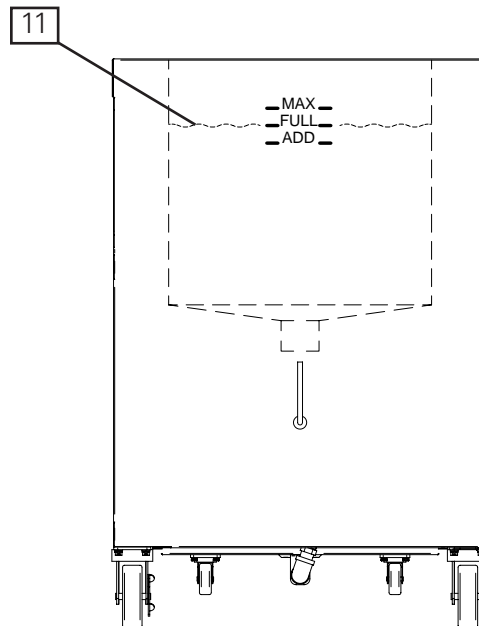

- Place the Cooking Basket on the Basket Carrier.

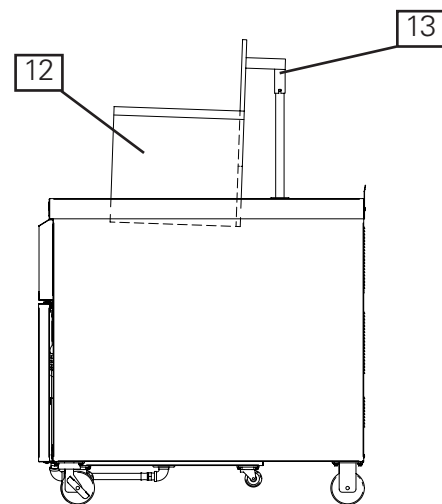

Fryer Operation

Model: GEF-400, GEF-560, GEF-720 &
GEF-400-VH, GEF-560-VH, GEF-720-VH

5-2. Cooking Procedure (Continued)

13. Press the Basket Button **14**. Then press the Down Arrow **15**. Cooking Basket will lower.

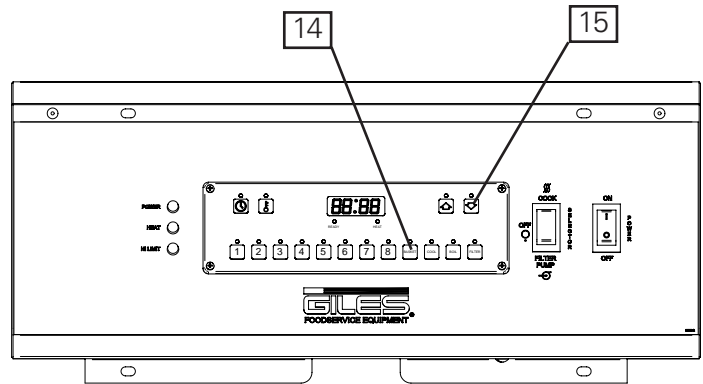

14. Uncooked product may be placed in the basket before or after the Cooking Basket has been lowered.

Use extreme caution when placing product in the HOT liquid shortening, as the HOT liquid shortening could cause severe burns.

Place the Basket Cover **16** on top of the Cooking Vat.

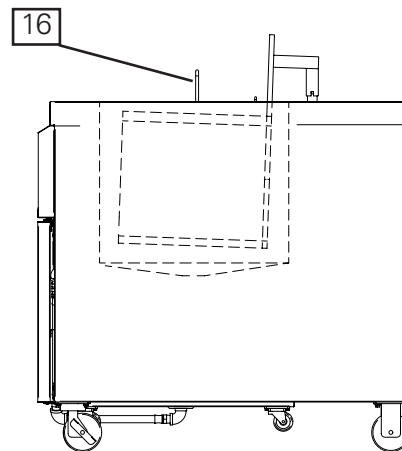

15. Press desired Menu Button **17** to begin the cooking cycle.

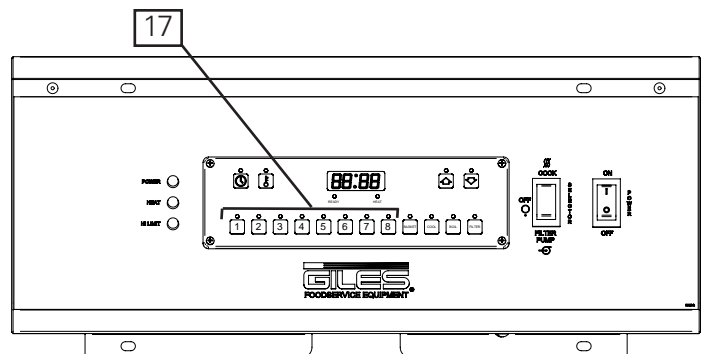

5-2. Cooking Procedure (Continued)

15. After 62% of the cooking time has elapsed from the selected cooking cycle, the stir cycle alarm will sound. Press the selected cooking cycle Menu Button to silence the alarm. Using Oven Mitts remove the Basket Cover **18** then stir the product with the **19** Stir Paddle.
16. Place the Basket Cover **18** on top of the Cooking Vat.

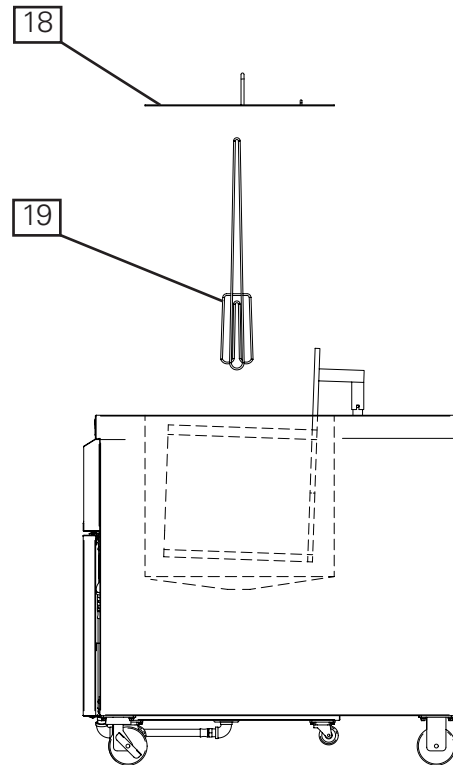

17. At the end of the cooking cycle the Cooking Basket **20** and the cooked product will automatically raise from the Hot Liquid Shortening.
18. Allow the cooked product to adequately drain. Then, using Oven Mitts, remove the Basket Cover, then using Oven Mitts. remove the Cooking Basket.
19. Place cooked product in an appropriate container.
20. Choose one of the following:
 - a.) To continue cooking on the unit return to step 6 of this procedure.
 - b.) To place the unit in the Cool Mode see Section 5-1.8 Cool Mode.
 - c.) To shut down the unit, see Section 5-5 Normal Shut-Down.

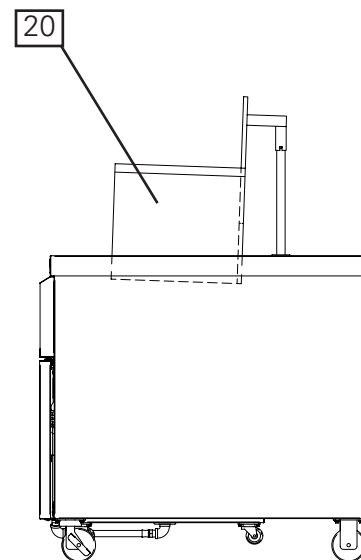

Fryer Operation

Model: GEF-400, GEF-560, GEF-720 &
GEF-400-VH, GEF-560-VH, GEF-720-VH

5-3. Filtering Liquid Shortening

This section describes how to filter Liquid Shortening through the built-in filtration system. The filtration system recirculates the Liquid Shortening through the Filter Pan, Filter Paper and Cooking Vat. By following this process you will increase the Liquid Shortening life up to 50%. The Cooking Controller is preset to alert you to filter every fourth load.

Warning: Never try to filter cold Liquid Shortening, this could clog the filter pump and damage the unit. Liquid Shortening must be heated to a minimum of 200°F (93°C) before filtering.

1. After cooking the fourth load the Cooking Controller will display **FILT** [1] and will sound an alarm. This indicates it is time to filter the liquid shortening.
2. Press the Filter Button [2] to silence the alarm.
3. Press the Selector Switch to the OFF [3] position.
4. Open the Cabinet Door. Wearing Oven Mitts, disconnect the Filter Pan Quick Disconnect Hose [4] then remove the Filter Pan [5] from the unit.
5. Ensure the Filter Pan has (2) sheets of Filter Paper installed correctly.
6. Add one package (4.8 ounces) of Giles Filter Powder (Part No. 72004) into the Filter Pan.
7. Ensure the Filter Pan Cover [6] is in place, then reposition the Filter Pan in the unit and reconnect the Filter Pan Quick Disconnect Hose [4].
8. **DANGER In this step Liquid Shortening is drained into the Filter Pan. Failure to ensure the fryer's Selector Switch is in the OFF position prior to draining may result in fire from the exposed Heating Elements. ALWAYS ENSURE THE SELECTOR SWITCH IS IN THE OFF POSITION BEFORE DRAINING LIQUID SHORTENING.**

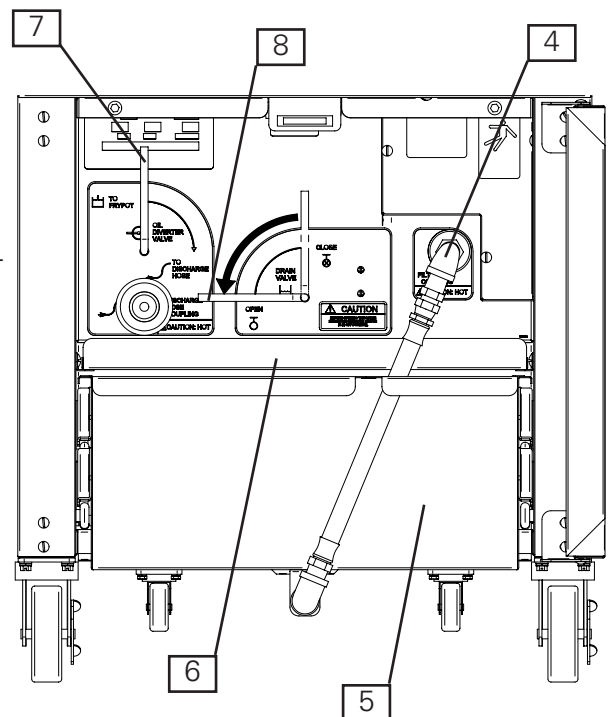
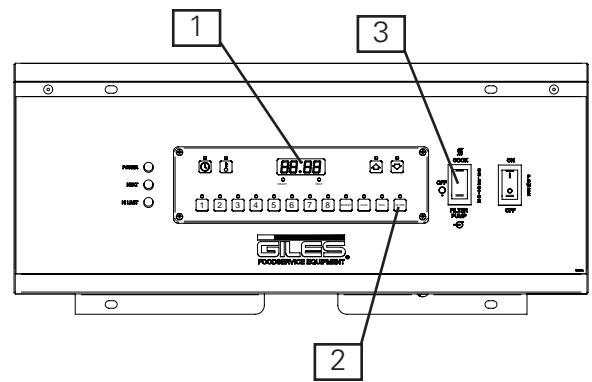

Ensure the Selector Switch is in the OFF [3] position. Ensure the Oil Diverter Valve is in the TO FRYPOT [7] vertical position. Slowly turn the Drain Valve Handle to the OPEN [8] horizontal position. This will allow Liquid Shortening to drain into the Filter Pan.

5-3. Filtering Liquid Shortening (Continued)

NOTE If the Fry Pot does not drain use the supplied Kettle Drain Brush to break up the crumbs in the Fry Pot Drain. **Be careful to not puncture the filter paper in the filter pan, this could cause the filter pump to clog and damage the unit.**

9. Once the Fry Pot has completely drained into the Filter Pan, press the Selector Switch to the FILTER **9** position.

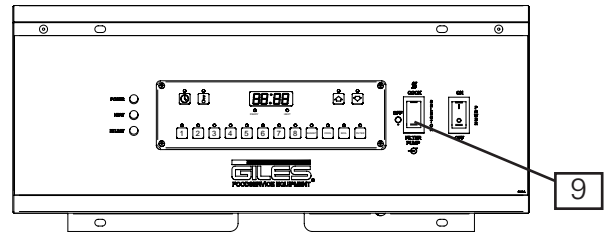

10. The Liquid Shortening will begin to recirculate **10** through the Filter Pan and back to the Fry Pot. Leave the Drain Valve open and allow the Liquid Shortening to continually circulate for a minimum of 5 minutes.

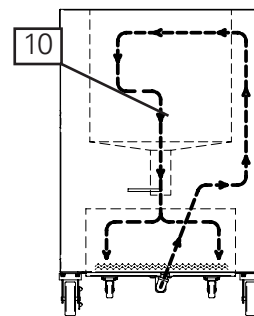

11. Allowing the Liquid Shortening to circulate for a minimum of 5 minutes, then turn the Drain Valve Handle to the CLOSE **11** vertical position and allow the Fry Pot to refill.

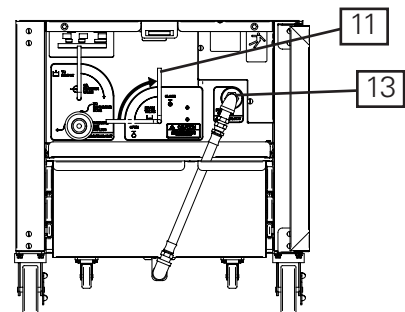

12. After the Fry Pot has refilled, press the Selector Switch to the OFF **12** position.

13. Ensure the Fry Pot contains the proper level of Liquid Shortening, add if needed.

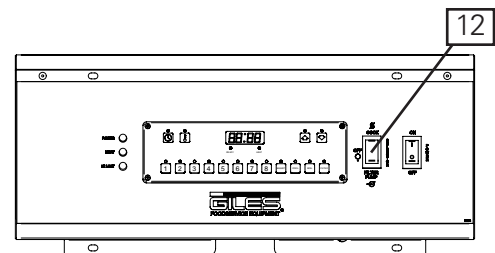

14. **Using Oven Mitts**, disconnect Quick Disconnect **13** and the remove the Filter Pan.

15. Using supplied Crumb Scoop **14**, remove sediment from inside the Filter Pan.

16. Reinstall Filter Pan.

17. To continue cooking, See Section 5-2, Cooking Procedure.

To discontinue cooking, See Section 5-5, Normal Shut Down.

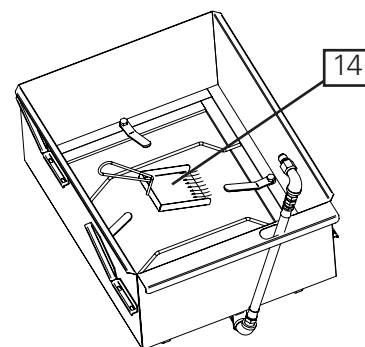

Fryer Operation

Model: GEF-400, GEF-560, GEF-720 & GEF-400-VH, GEF-560-VH, GEF-720-VH

5-4. Removal of Liquid Shortening

This section describes how to remove Liquid Shortening from the unit. Liquid Shortening must be removed from the fryer before a Boil Out is performed. In this section a Giles Oil Caddy (not included) is used to dispose the used Liquid Shortening.

Warning: Never try to remove cold Liquid Shortening using this procedure, this could clog the filter pump and damage the unit. Liquid Shortening must be heated to a minimum of 200°F (93°C) before following this procedure.

1. If the Liquid Shortening is cold, heat to 200°F (93°C).
2. Ensure the Power Switch is in the ON **1** position.
3. Ensure the Selector Switch is in the OFF **2** position.

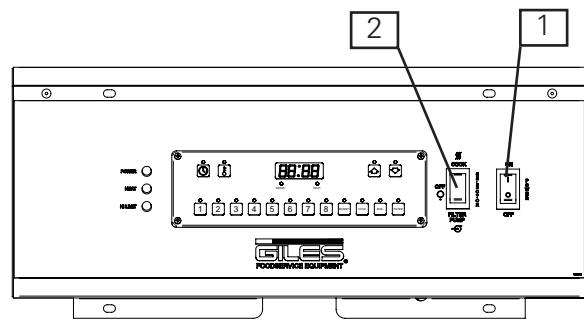

4. Ensure the Filter Pan **3** is in place and the quick disconnect hose **4** is connected to the unit.
5. Slowly turn the Drain Valve Handle to the OPEN **5** horizontal position and allow the Fry Pot to completely drain.

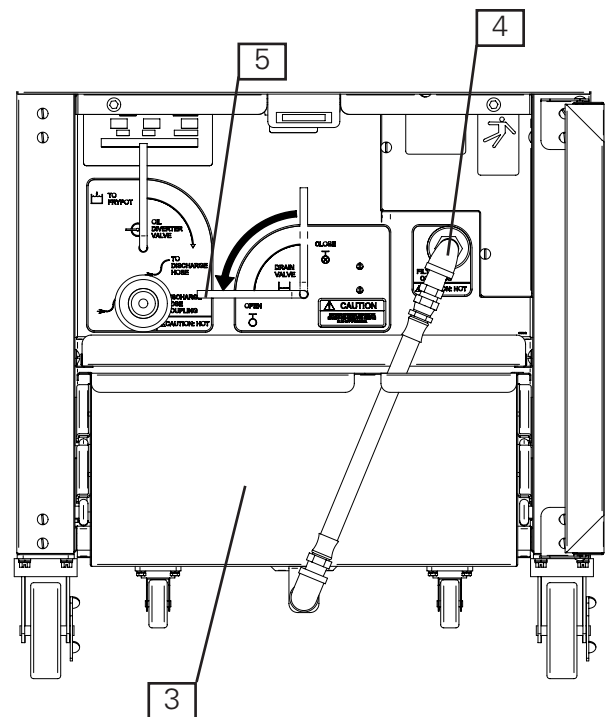

5-4. Removal of Liquid Shortening (Continued)

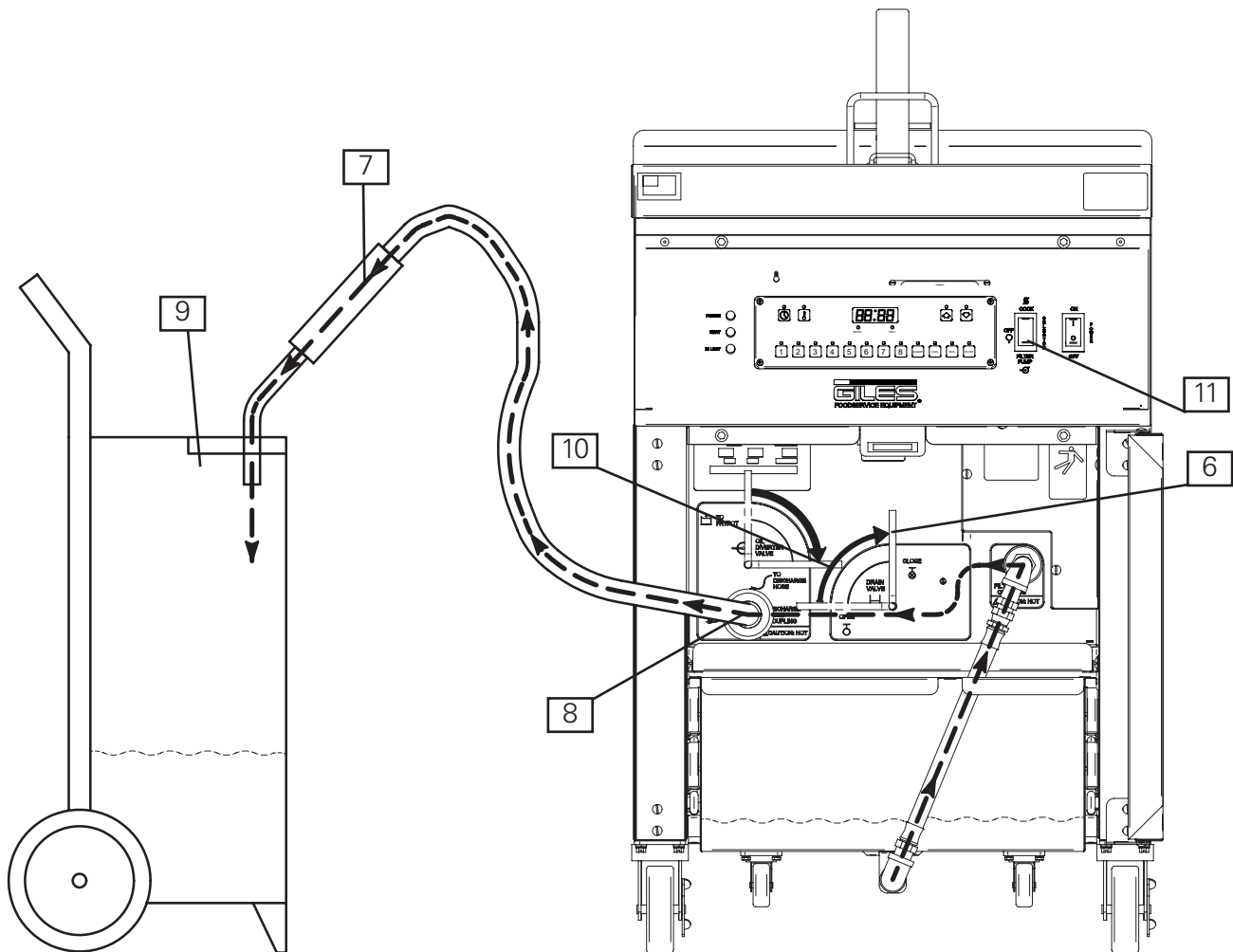

6. After the Fry Pot has completely drained, Turn the Drain Valve Handle to the CLOSED [6] vertical position.
7. Connect the Discharge Hose [7] to the Discharge Hose Coupling [8].
8. Place the discharge end into a Hot Oil Disposal Container [9] (Giles Oil Caddy shown).
9. Turn the Oil Diverter Valve to the TO DISCHARGE HOSE [10] horizontal position.
10. **Be sure the wear Oven Mitts if holding the Discharge Hose, as the hose will become very hot,** Press the Selector Switch to the PUMP/FILTER [11] position and allow the liquid shortening to pump into the Disposal Container.

Fryer Operation

Model: GEF-400, GEF-560, GEF-720 &
GEF-400-VH, GEF-560-VH, GEF-720-VH

5-4. Removal of Liquid Shortening (Continued)

11. After the Liquid Shortening is removed from the Filter Pan, press the Selector Switch to the OFF **12** position.

12. Press the Power Switch to the OFF **13** position.

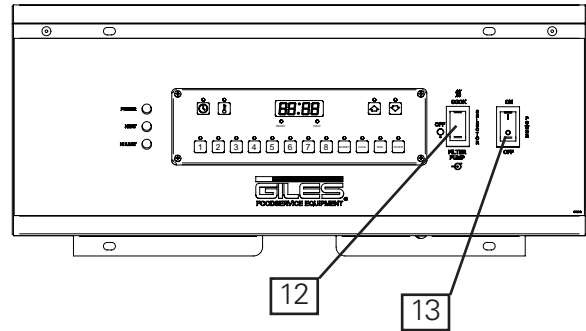

13. Turn the Oil Diverter Valve handle to the TO FRYPOT **14** vertical position.

14. **Wearing Oven Mitts** remove the Discharge Hose from the Discharge Hose Coupling **15** and drain the excess Liquid Shortening remaining in the hose into the Oil Disposal Container.

15. Thoroughly clean the Filter Pan and the Filter Pan Cover.

16. To perform a Boil Out on the unit see Section 6-1 Boil Out Procedure.

To shut down the unit see Section 5-5 Normal Shut-Down.

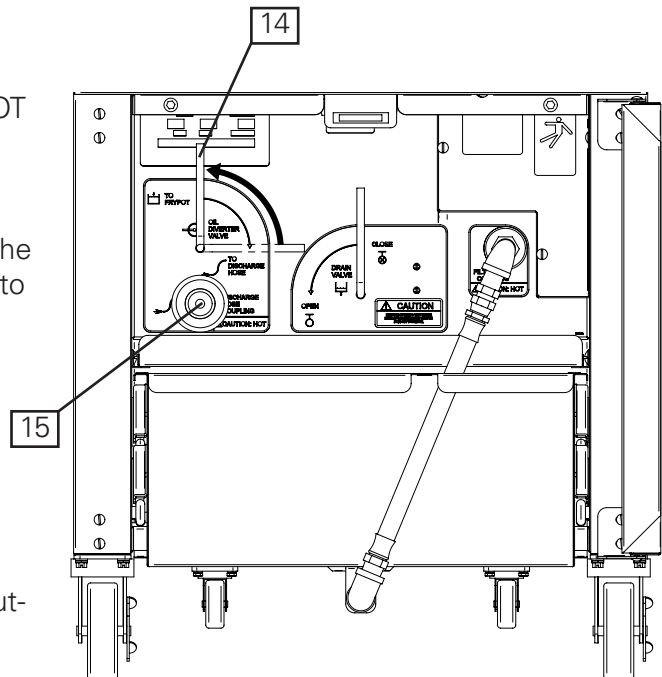

5-5. Normal Shut-Down

This section explains the process of shutting the unit down.

1. Press the Selector Switch to the OFF **1** position.
2. Press the Power Switch to the OFF **2** position, the Power Light **3** will go off.
3. If required, turn off the fryer circuit breaker in the main circuit breaker box to remove power to the unit.

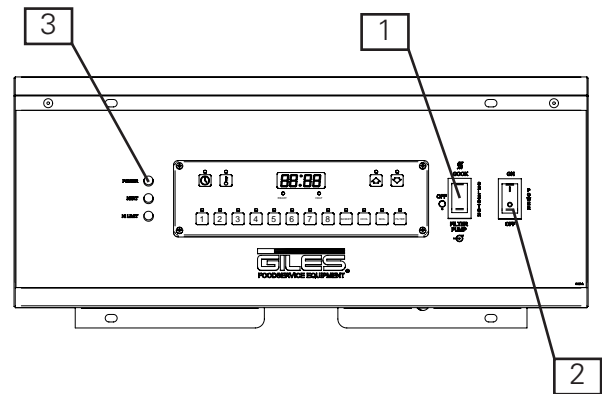

5-6. Emergency Shut-Down

In case of emergency, remove power to the unit by turning off the facility circuit breaker.

Cleaning

Model: GEF-400, GEF-560, GEF-720 &
GEF-400-VH, GEF-560-VH, GEF-720-VH

6. Cleaning

This section describes the cleaning operations for the GEF-400, GEF-560, GEF-720, GEF-400-VH, GEF -560-VH and GEF-720-VH. The unit should be cleaned on a daily basis.

! DANGER

- **DO NOT** hose down the GEF-400, GEF-560, GEF-720, GEF-400-VH, GEF -560-VH or GEF-720-VH interior or exterior with water.
- Failure to comply with these **DANGER** notices will result in death or serious injury, equipment/property damage, and void the warranty.

6-1. Boil-Out Procedure (Cleaning the Fry Pot)

This section describes how to clean the Fry Pot in the unit, this process is referred to as "Boil-Out". A "Boil-Out" must be performed before cooking with new equipment and should be performed each time liquid shortening is removed from the unit.

For proper operation of the fryer, the Boil-Out procedure should be carried out every 7 to 14 days.

DANGER DO NOT under any circumstances leave the fryer unattended during this procedure as heat must be carefully monitored to prevent the Fry Pot from overflow due to boiling. Overflow of the Fry Pot may result in serious equipment damage.

1. Remove Liquid Shortening from the unit, see Section 5-4. Removal of Liquid Shortening.
2. Ensure the Drain Valve is in the CLOSED **1** vertical position and the Power Switch is in the OFF **7** position.
3. Fill the Fry Pot with water to the FULL level **2**.
4. Following the directions on the Giles Boil-Out Container, add the recommend amount of Boil-Out to the Fry Pot.

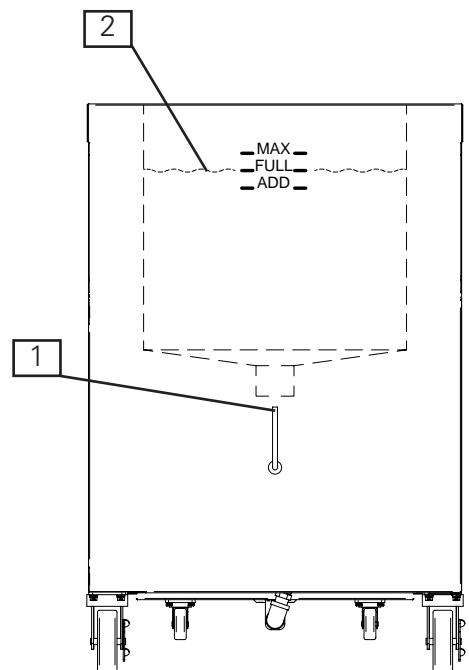

CAUTION If using a cleaner other than Giles Boil-Out pay close attention to the instructions listed on the container. Many commercially available cleaners are caustic chemicals which require special precautions. If used improperly, these chemicals may cause damage to the fryer and potential injury to the user.

6-1. Boil Out Procedure (Continued)

5. Press the Power Switch to the ON **3** position.
6. Press the Selector Switch to the HEAT **4** position.
7. Press and hold the Boil button **5** for 5 seconds to place the unit in the Boil Out mode. The Boil Out Solution will heat to 200°F (93°C). See directions on Boil Out container for suggested cycle time.
8. At the completion of the Boil Out Cycle time press the Selector Switch to the OFF **6** position and the Power Switch to the OFF **7** position.

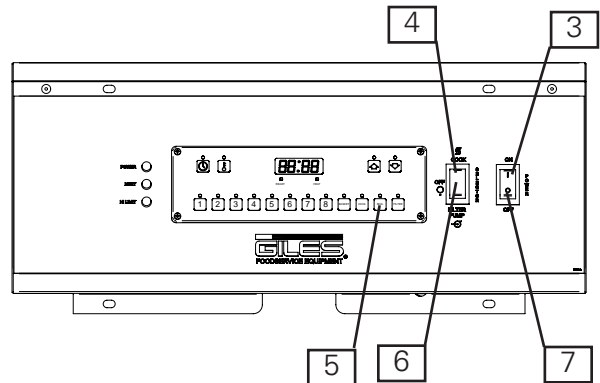

9. Disconnect Quick Disconnect Hose, remove the Filter Pan, then remove the Filter Pan Cover.

WARNING DO NOT drain the Boil-Out into the Filter Pan! Contents are corrosive and will cause damage to the Filter Pan, the Hold-Down Frame, and the Filter Pump. Failure to comply may result in minor or moderate injury, equipment/property damage, and void the warranty.

10. Position a suitable **Heat Resistant Container** **8** (not supplied with the unit) beneath the Fryer Drain.

CAUTION Always ensure the container which is used for this step is heat resistant up to 300°F (148°C). Plastic is generally not safe as it may melt or break. Metal containers which do not leak are preferable to containers made of other materials. Failure to comply with this caution may result it serious injury.

11. Slowly turn the Drain Valve Handle to the OPEN **9** horizontal position.
12. Rinse and flush the Fry Pot thoroughly with tap water.
13. Dry fry pot with a clean dry towel.

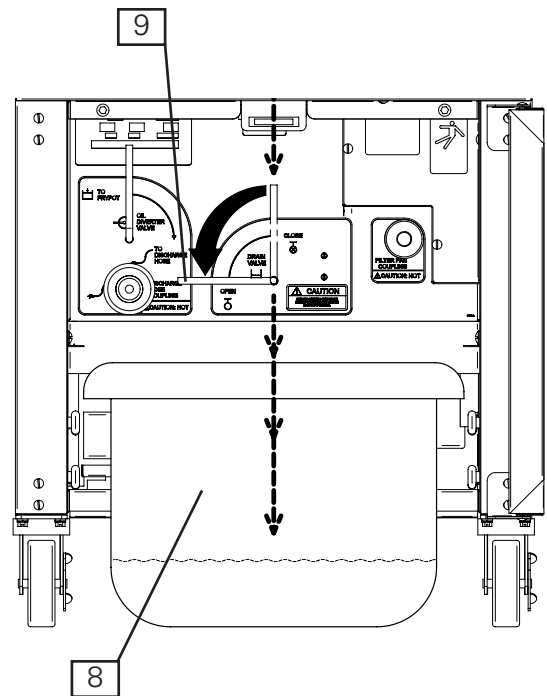

Cleaning

Model: GEF-400, GEF-560, GEF-720 &
GEF-400-VH, GEF-560-VH, GEF-720-VH

6-1. Boil Out Procedure (Continued)

14. Slowly turn the Drain Valve Handle to the CLOSE 10 vertical position.
15. Clean Filter Pan and replace Filter Paper; follow directions in Section 6-2, Cleaning of Filter Pan Components after the Boil Out procedure.
16. Re install Filter Pan Cover 11.
17. Position Filter Pan 12 under unit and connect Filter Pan Quick Disconnect Hose 13.
18. To begin cooking on the unit, see Section 5-2.

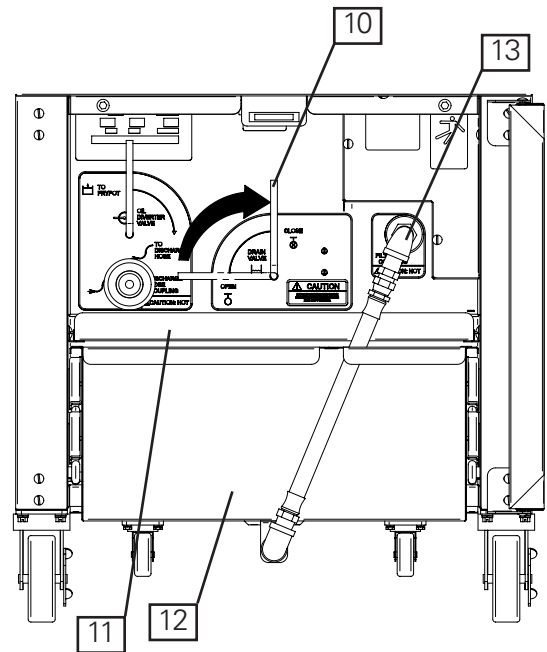

6-2. Cleaning the Filter Pan and replacing Filter Paper after Boil Out

This section explains the process for cleaning the Filter Pan and the replacement of the Filter Paper. This process should be carried out each time you perform a Boil Out Procedure (Section 5-5).

Use Thermal Mitts for protection from hot parts.

1. Follow the Normal Shut-Down procedure, see Section 5-5.
2. Remove the Filter Pan [1] and the Filter Pan Cover [2].
3. Clean Filter Pan Cover [2] thoroughly.
4. Remove the Crumb Screen [*3] and clean thoroughly.
5. Using metal Crumb Scoop provided with the unit, remove the accumulated breadings and residue from the edge of the Hold Down Frame [4] and surface of the Filter Paper [5].
6. Turn the four Levers [6] to disengage the Hold-Down Frame [4] from the bottom of Filter Pan.
7. Remove the Hold-Down Frame [4], then clean and dry thoroughly.
8. Grasp one end of the Filter Paper [5] and carefully roll up both [5] sheets, then discard them.
9. Remove the Screen [7], then clean and dry thoroughly.
10. Thoroughly clean and dry the Filter Pan [8].
11. Reassemble the Filter Pan using (2) new sheets of Filter Paper.
12. Reinstall Filter Pan Cover, then the Filter Pan Assembly.

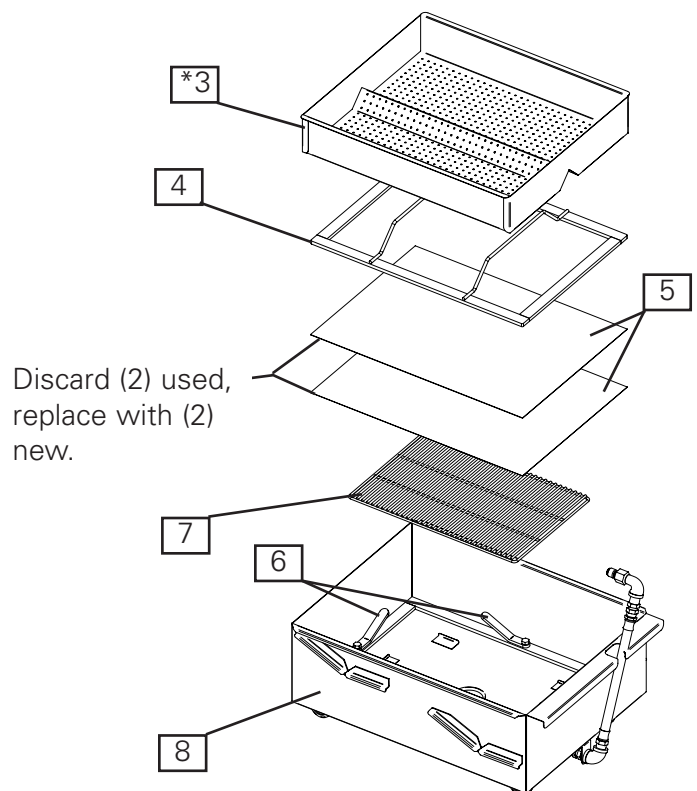
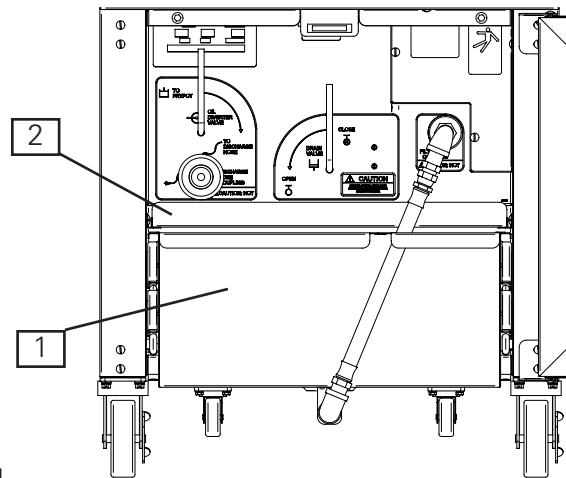

* -Accessory Item, not included

Cleaning

Model: GEF-400, GEF-560, GEF-720 &
GEF-400-VH, GEF-560-VH, GEF-720-VH

6-3. Cleaning the Filter Pan and replacing the Filter Paper daily

This section explains the process for cleaning the Filter Pan and the replacement of the Filter Paper daily. This process should be carried out daily.

Use Thermal Mitts for protection from hot parts.

1. Follow the Normal Shut-Down procedure, see Section 5-5.
2. Disconnect Quick Disconnect hose, remove the Filter Pan **1** and the Filter Pan Cover **2**.
3. Clean Filter Pan Cover **2** thoroughly.
4. Remove the Crumb Screen ***3** and clean thoroughly.
5. Using metal Crumb Scoop provided with the unit, remove the accumulated breadings and residue from the edge of the Hold Down Frame and surface of the Filter Paper **5**.
6. Turn the four Levers **8** to disengage the Hold-Down Frame **4** from the bottom of Filter Pan.
7. Remove the Hold-Down Frame **4**, then clean and dry thoroughly.
8. Grasp top sheet of Filter Paper **5** by one end, carefully roll up and discard.
9. Grasp bottom sheet **6** of Filter Paper by both ends and remove; retain for reuse.
10. Remove the Screen **9**, then clean and dry thoroughly.
11. Thoroughly clean and dry the Filter Pan **10**.
12. Reassemble the Filter Pan using (1) new sheet of Filter Paper **7**.
13. Reinstall Filter Pan Cover, then the Filter Pan Assembly into the unit.

* -Accessory Item, not included

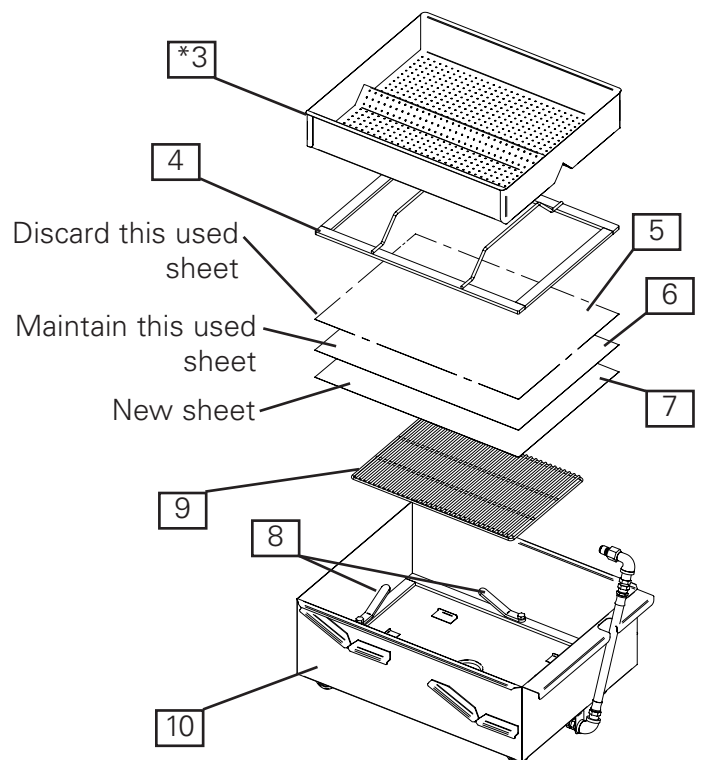
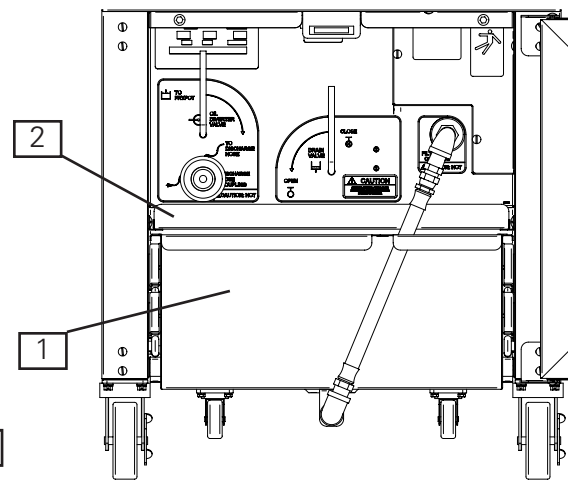

**Model: GEF-400, GEF-560, GEF-720 &
GEF-400-VH, GEF-560-VH, GEF-720-VH**

Cleaning



Notes:

Ventless Hood

Model: GEF-400, GEF-560, GEF-720 &
GEF-400-VH, GEF-560-VH, GEF-720-VH

7. Ventless Hood

This section applies to the Ventless Hood (VH) models only. It describes the operation and maintenance of the Ventless Hood and the Filters contained in the hood.

7-1. Hood Operation

This section describes how to start the Ventless Hood. Make use all the Filters are in place before operating the unit.

- Place the Power Switch in the ON **1** position, (if ILS, press and hold the "Push and Hold to Start" switch ***2** for 5 seconds) the Power Light **3** and EAC On light **4** will come on and the UV Sight Window ****5** will illuminate.

This will turn the unit on and the ventless hood fan will begin running.

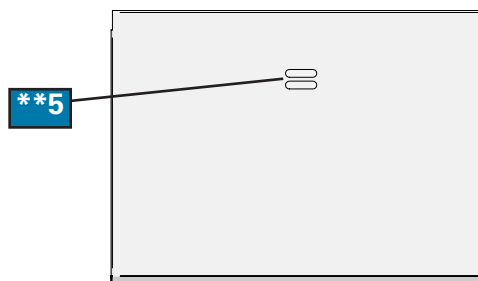
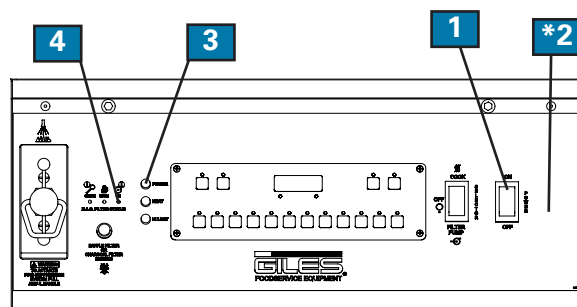

* -Not Shown
** -UV Only

7-2. Filters

This section describes each Filter in the Ventless Hood.

7-2.01. Ventless Hood Filter Table

Filter	When to clean or replace	How to remove	How to clean	How to install
Baffle Filter	Clean Daily	Section 7-2.02	Section 7-02.05	Section 7-02.03
EAC Filter	Clean Daily	Section 7-02.06	Section 7-02.09	Section 7-02.07
Charcoal Filter	Replace every 30 days, P/N 30248	Section 7-02.10	Never clean, only replace	Section 7-02.11
Ultra Violet Lamp	Clean every 30 days Replace annually	Section 7-02.15	Section 7-02.14	Section 7-02.16

7-2.02. Baffle Filter Removal

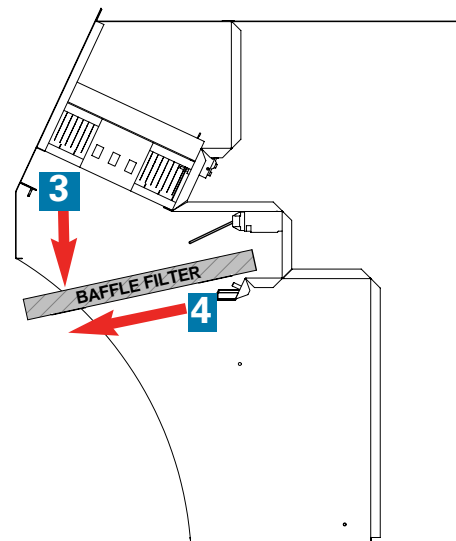
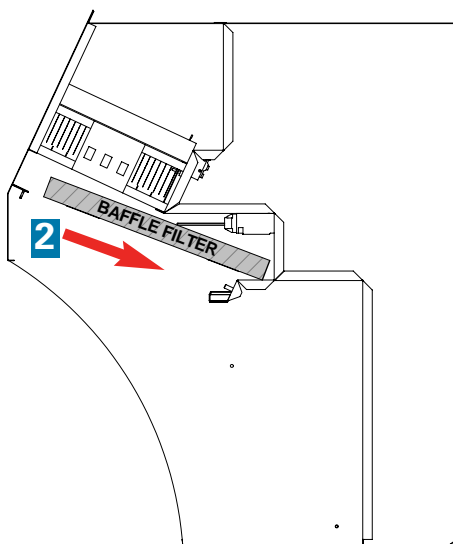
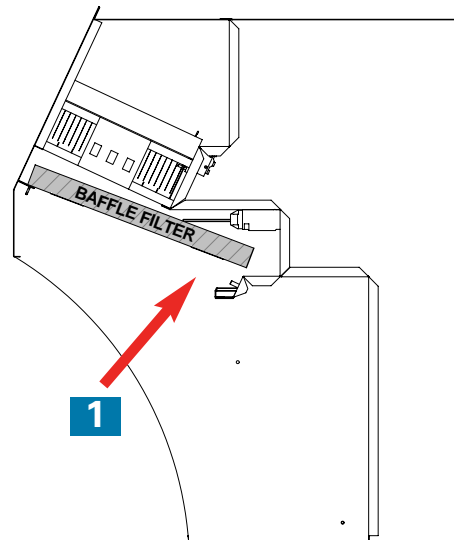
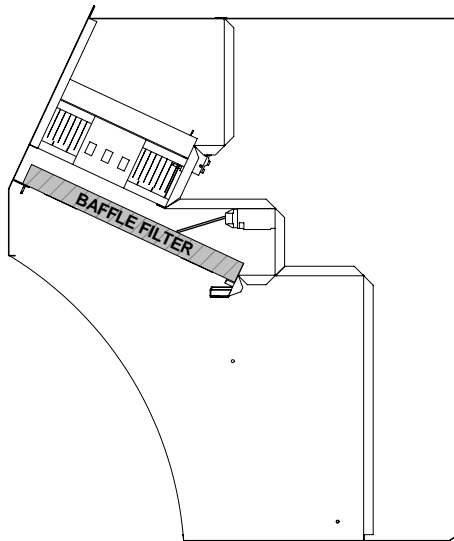

Ventless Hood

Model: GEF-400, GEF-560, GEF-720 &
GEF-400-VH, GEF-560-VH, GEF-720-VH

7-2.03. Baffle Filter Installation

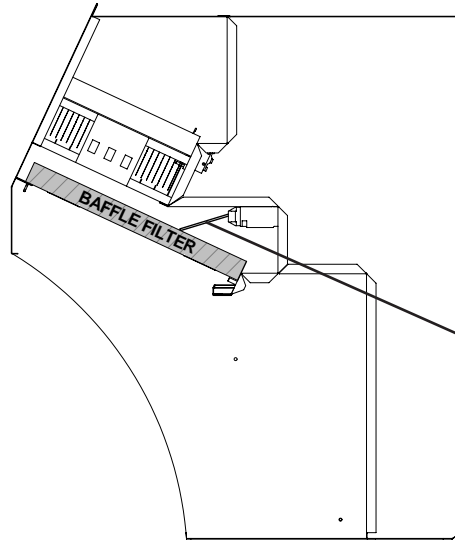
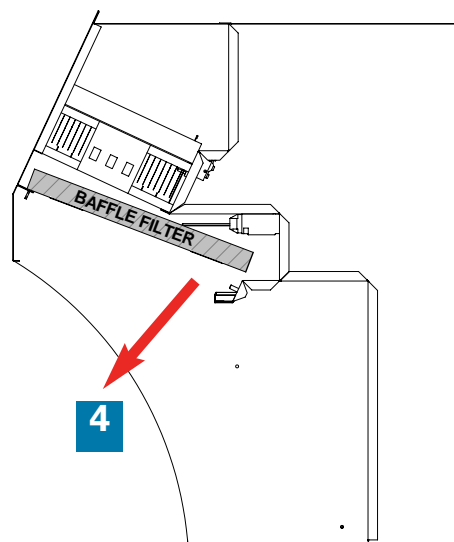
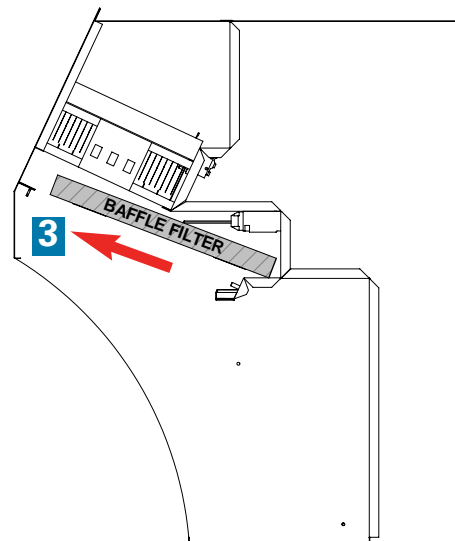
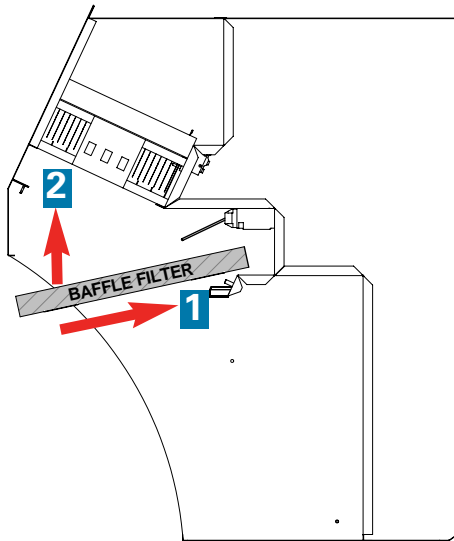

Switch arm must be actuated by the Baffle Filter as shown

7-2.04. Baffle Filter Missing

If the Baffle Filter is missing or not in place correctly the Filter Missing Light **1** will come on. See Section 7-2.03 Baffle Filter Installation.

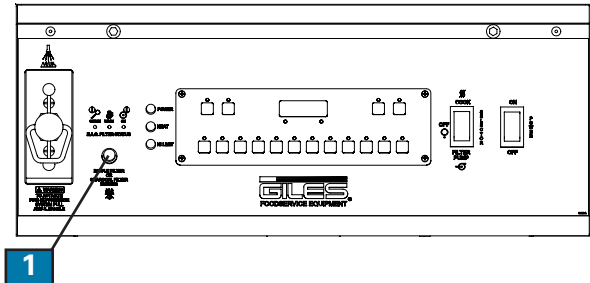

7-2.05. Baffle Filter Cleaning

The Baffle Filter should be cleaned daily. Place the Baffle Filter in a sink and clean with a mild degreaser. Dry thoroughly, then reinstall in the unit.

7-2.06. EAC Filter Removal

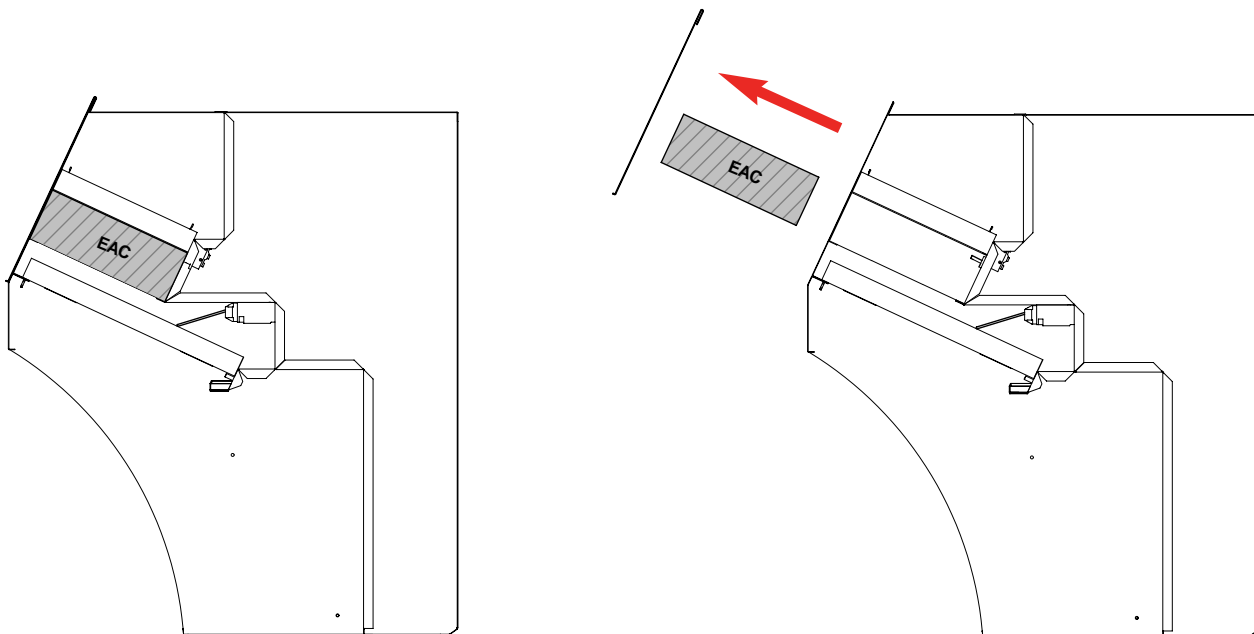

Ventless Hood

Model: GEF-400, GEF-560, GEF-720 &
GEF-400-VH, GEF-560-VH, GEF-720-VH

7-2.07. EAC Filter Installation

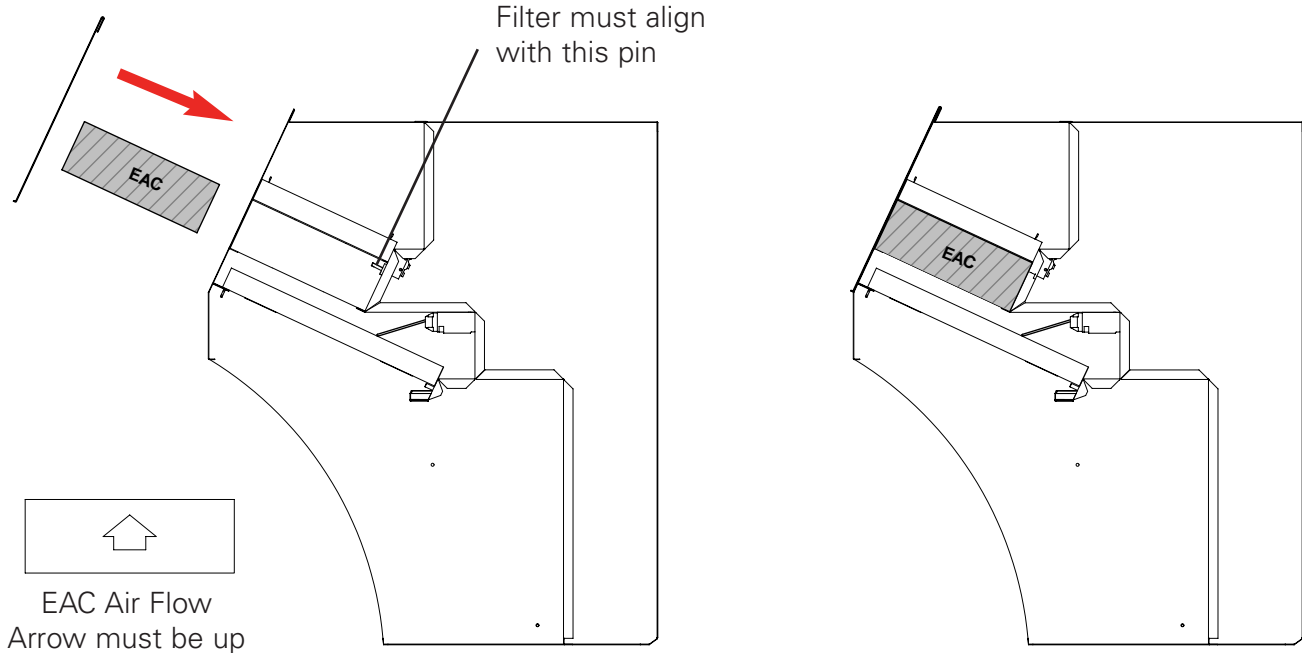

7-2.08. EAC Filter Status

The three indicator lights on the Control Panel display the status of the EAC Filter.

- 1** ON The EAC Filter is in place and powered.
- 2** WASH The EAC Filter is becoming excessively dirty and must be cleaned. If this light is on for more than 2 minutes an intermittent alarm will sound, the Elements and the Heat Light will turn off.
- 3** CHECK The EAC Filter is not operating, either the filter is not getting a proper electrical connection or it is damaged. If this light is on for more than 2 minutes an intermittent alarm will sound, the Elements and the Heat Light will turn off.

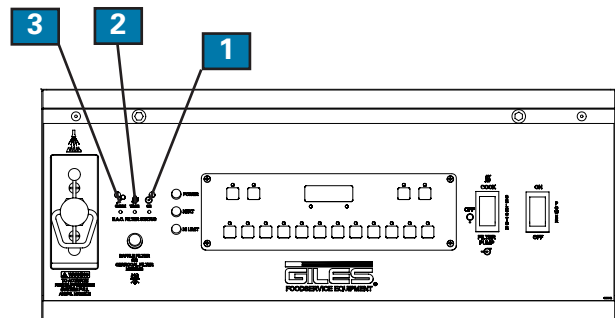

7-2.09. EAC Filter Cleaning

The EAC Filter should be cleaned daily.

Be careful not to bend the fins or break the ionizer wires on the EAC as this will prevent the EAC from working properly and shut off the power to the heating elements.

1. Mix a mild degreaser, such as Simple Green or Clean Magic, with 6.5 gallons of water in the included Soak Tank **1**.
2. Holding the contact plate **2** on the EAC **3** slowly lower the filter into the Soak Tank.
3. After allowing the EAC to soak for 20 to 30 minutes, using the contact plate **2**, lift the EAC up and down approximately 1" to 2" to help remove the grease residue.
4. Slowly remove the EAC from the tank and rinse clean in a sink using hot water.
5. Allow the EAC to thoroughly dry.

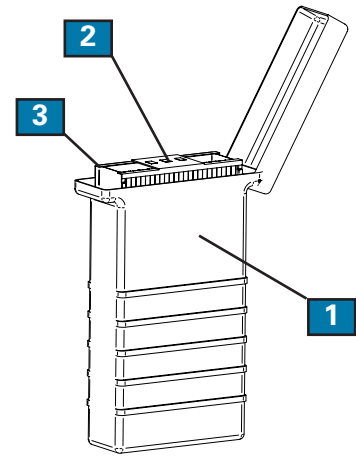

7-2.10. Charcoal Filter Removal

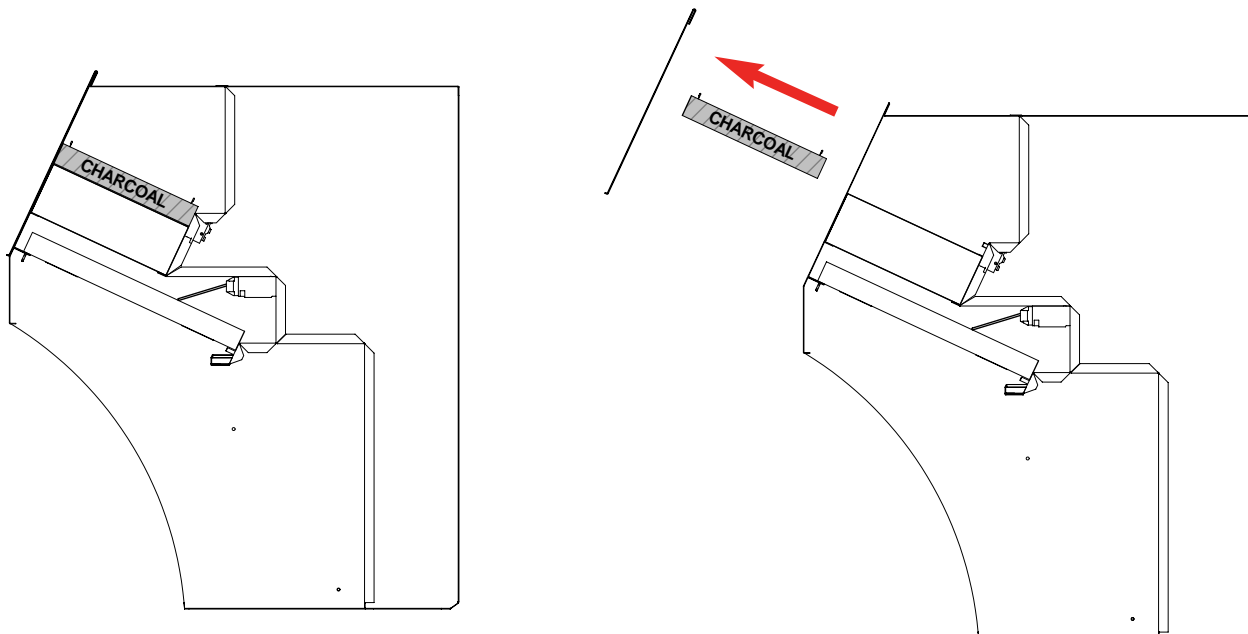

Ventless Hood

Model: GEF-400, GEF-560, GEF-720 &
GEF-400-VH, GEF-560-VH, GEF-720-VH

7-2.11. Charcoal Filter Installation

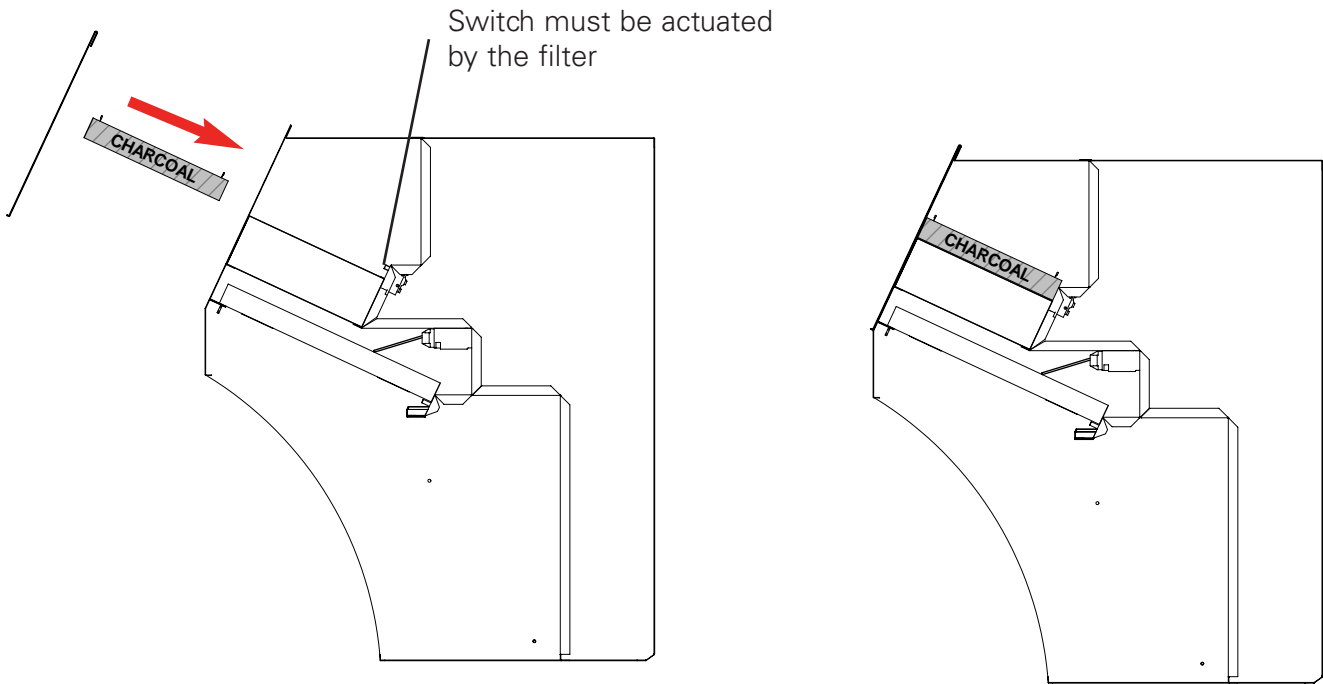

7-2.12. Charcoal Filter Missing

If the Charcoal Filter is missing or not in place correctly and the unit is on, the Filter Missing **1** Light will come on. See Section 7-2.11 Charcoal Filter Installation.

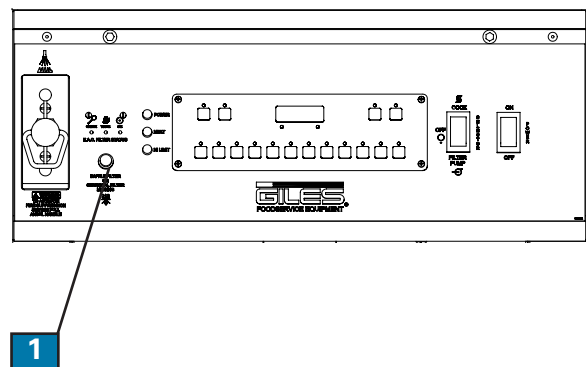

7-2.13. Charcoal Filter Replacement

Never attempt to clean the Charcoal Filter. This could cause damage to the unit.

Replace the Charcoal Filter every 30 days. Use Replacement Part No. 30248.

7-2.14. Ultra Violet Lamp Cleaning

CAUTION

- **Do Not touch or handle UV Lamp with bare hands. This will greatly reduce the life of bulb.**

To be accomplished every 30 days

1. Place hood power switch off.
2. Remove filter access cover
3. Loosen and remove thumb screws at top of lamp guard.
4. Lightly spray a mild non-caustic biodegradable degreaser, such as Simple Green, onto the UV Light and wipe off residue with a dry, lint free cloth
5. Re-install lamp guard.

7-2.15. Ultra Violet Lamp Removal

1. Place hood power switch **1** to the OFF position.
2. Remove filter access cover **2**.
3. Disconnect UV Lamp wiring harness from power supply wiring harness **3**.
4. Loosen and remove thumb screws and UV lamp guard **3**.
5. Remove Lamp from holding brackets **5**.

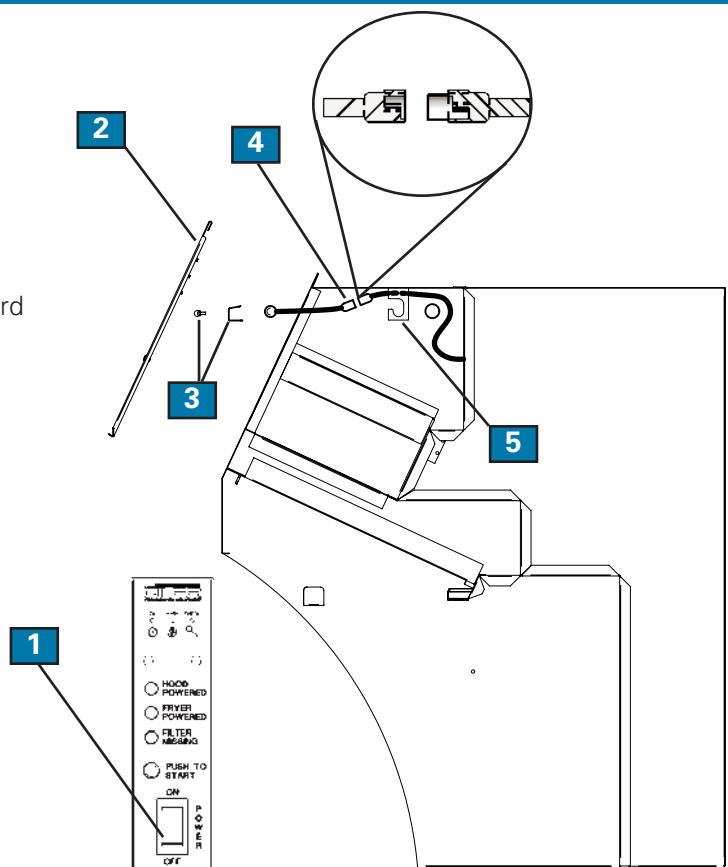

Ventless Hood

Model: GEF-400, GEF-560, GEF-720 &
GEF-400-VH, GEF-560-VH, GEF-720-VH

7-2.16. Ultra Violet Lamp Removal

1. Install new UV lamp in holding brackets **1**.
2. Install lamp guard and tighten thumb screws **2**.
3. Connect UV Lamp wiring harness to power supply wiring harness **3**.
4. Install all filters and access cover **4**.
5. Place hood power switch on **5**.

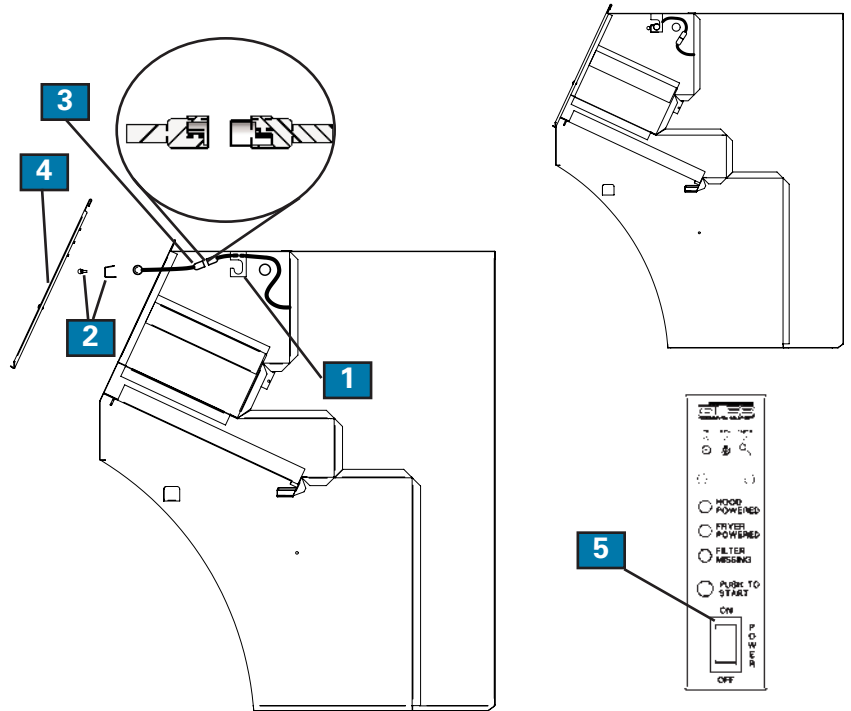

7-2.17. Hood Filter Alarm Chart

Alarm Sound	What will happen	Filter effected	Cause	Solution	See Section
Continuous beep	Alarm will sound and the power to the Fryer Heating Elements will shut off. (If ILS, the power to the Fryer and Hood with shut off)	Charcoal	Filter dirty	Replace Filter	4-02.15. and 4-02.17.
Continuous beep	Alarm will sound and the power to the Fryer Heating Elements will shut off. (If ILS, the power to the Fryer and Hood with shut off)	Baffle	Filter dirty	Clean Filter	4-02.03. and 4-02.05
Intermittent beeping	Alarm will sound for 2 minutes then power to the Fryer Heating Elements will shut off. (If ILS, the power to the appliance and hood with shut off)	E.A.C.	Filter dirty	Clean Filter	4-02.11. and 4-02.13

7-3. Maintenance

This Section describes the Ventless Hood (VH) System's periodic maintenance which will maintain its efficiency over time.

A **Maintenance and Service Log** is provided in this manual, see Table 7-3.6.

7-3.1. Monthly Interlock Check

Your Giles Ventless Hood System incorporates an Interlock System to ensure the unit is operated in a safe and effective manner. Testing of the Interlock System should be conducted MONTHLY in the following manner. Place a check in the box that corresponds to the test being performed. If a problem is found call your service representative.

1. **Baffle Filter Check**-With the Power Switch in the "OFF" position remove the grease baffle. Place the Power Switch in the "ON" position and the Selector Switch in the "COOK:" position. The heat light should not come on. Turn the Power Switch to the "OFF" position and reinstall the grease baffle into the hood.
2. **EAC Filter Check**-Remove the EAC. Place the Power Switch in the "ON" position and the Selector Switch in the "OFF" position, wait two minutes and then move the Selector Switch to the "ON" position. The heat light should not come on. Return Selector Switch to its "Off" position. Reinstall the EAC.
3. **Charcoal Filter Check**-Remove the Charcoal Filter. Place the Power Switch in the "ON" position and the Selector Switch in the "COOK" position. The heat light should not come on. Return all switches to their "OFF" position. Reinstall the charcoal filter.
4. **Filter Clogged Check**-Place the Power Switch in the "ON" position and the Selector Switch in the "COOK" position. Place a piece of filter paper over the Grease Baffle Filter. The heat light should not come on. A buzzer will sound in approximately two minutes if the paper is not removed. Return all switches to their "OFF" position. Remove the test paper.

7-3.2. Quarterly Hood Cleaning

Remove power from the unit. Remove the Filter Cover and all Filters from the hood. Using a mild degreaser clean the entire Hood Plenum and Blower Sections. The hood must be cleaned every 3 months.

7-3.3. Semi-Annual Fire Suppression System

Service of the fire suppression system is to be conducted by qualified fire equipment personnel. As a minimum, field inspection of the Fire Suppression System is to be accomplished semi-annually by qualified fire equipment service personnel. Such maintenance shall consist of the following **(Consult the Giles Enterprises Design Installation, Recharge and Maintenance Manual for complete servicing guidelines)**.

Place fire extinguishing system locking bar on fire system when servicing hood.

1. Remove charging cartridge, inspect gasket for cuts and elasticity, coat gasket with extreme temperature grease and reinstall. See Section 2-08. Fusible Link and Gas Cartridge Locations
2. Remove tank, verify chemical is at proper level, clean and coat O-ring with extreme temperature grease and reinstall. See Section 2-09. Fire Extinguisher Nozzle and Tank Locations
3. Check all nozzles to insure they are free of cooking grease buildup.
4. Test the remote manual pull station for activation and wear.
5. Install test link and cut to simulate automatic actuation.
6. Clean and inspect fusible links. See Section 2-08. Fusible Link and Gas Cartridge Locations
7. Inspect wire rope for wear at pulleys and detectors and replace if necessary.
8. Record maintenance date and maintain in a permanent file.

7-3.4. Annual Fire Suppression System

Same as Semi-Annual but all fusible links must be replaced with new fusible links. See Section 2-08. Fusible Link and Gas Cartridge Locations

7-3.5. 12 Year Fire Suppression System

Same as Annual except for the following.

1. Replace R-102 fire suppression chemical.
2. Hydrostatically test the tank and cartridge.
3. Flow test the regulator.

Ventless Hood

Model: GEF-400, GEF-560, GEF-720 &
GEF-400-VH, GEF-560-VH, GEF-720-VH

7-3.6. Maintenance & Service Log

Check								Initial/Date	Check								Initial/Date			
✓	✓	✓	✓					ABC 1/2/03	1	2	3	4								
1	2	3	4						1	2	3	4								
1	2	3	4	5					1	2	3	4	5							
1	2	3	4						1	2	3	4								
1	2	3	4	5	6*				1	2	3	4	5	6*						
1	2	3	4						1	2	3	4								
1	2	3	4	5					1	2	3	4	5							
1	2	3	4						1	2	3	4								
1	2	3	4	5	6*	7*	8		1	2	3	4	5	6*	7*	8				
1	2	3	4						1	2	3	4								
1	2	3	4						1	2	3	4								
1	2	3	4	5					1	2	3	4	5							
1	2	3	4						1	2	3	4								
1	2	3	4	5	6*				1	2	3	4	5	6*						
1	2	3	4						1	2	3	4								
1	2	3	4	5					1	2	3	4	5							
1	2	3	4						1	2	3	4								
1	2	3	4	5	6*				1	2	3	4	5	6*						
1	2	3	4						1	2	3	4								
1	2	3	4	5					1	2	3	4	5							
1	2	3	4	5					1	2	3	4	5							
1	2	3	4	5	6*	7*	8		1	2	3	4	5	6*	7*	8				

- | | | | | | |
|---|---|---|--------------------|---|-------------------------------------|
| 1 | Baffle Filter Check | 2 | EAC Filter Check | 3 | Charcoal Filter Check |
| 4 | Filter Clogged | 5 | Quarterly Cleaning | 6 | Fire Suppression System |
| 7 | Fire Suppression System replace Fusible Links | | | 8 | Replace UV Lamp
(UV Option Only) |

* Inspection performed by a qualified fire equipment company.

8. Troubleshooting

This section describes troubleshooting procedures for the Giles Electric Fryer, Model GEF-400, GEF-560, GEF-720, GEF-400-VH, GEF-560-VH and GEF-720-VH. Refer to the wiring diagrams in Section 10 for more detailed analysis.

8-1. Temperature Control System		
Problem	Probable Cause	Repair Procedure
FRYER WILL NOT TURN ON: No power light * -ILS model only	A. Not connected to power source.	A. Connect to power source.
	B. Bad fuse or circuit breaker.	B. Check fuse or breaker.
	C. Fuse holder cracked.	C. Replace fuse holder.
	D. Power switch bad.	D. Replace Power Switch.
	E. Improper supply voltage.	E. Connect to proper voltage source.
	F. Hood cover not closed.	F. Close Hood Cover.
	G. Fire Suppression not armed.	G. Call local Ansul Dealer to arm.
	*H. "Push and Hold to Start" button not held down for a full 5 seconds.	*H. Hold down "Push and Hold to Start" button for 5 seconds.
FRYER WILL NOT HEAT: Power light on. Heat light not on.	A. Cook/Filter Switch not in cook position.	A. Place Cook/Filter Switch in cook position.
FRYER WILL NOT HEAT: Power light on. Cook/Filter Switch in cook position. Heat light not on.	A. Selected menu key programmed below present oil temperature.	A. Set temperature controller to desired temperature.
	B. Drain Valve open.	B. Close Drain Valve.
	C. Cooking computer faulty.	C. Replace Cooking Computer.
	D. Variable probe shorted or open.	D. Replace Probe.
	E. Loose wire.	E. Repair loose wire.
	F. Contactor failure.	F. Replace faulty contactor.
	G. Element bad.	G. Replace element.
	H. Selector Switch bad.	H. Replace Selector Switch.

8-1. Temperature Control System (Continued)

Problem	Probable Cause	Repair Procedure
FRYER WILL NOT HEAT: Power light on. Selector Switch in cook position. Filter missing light on. (VH Model Only)	A. Baffle Filter missing.	A. Install Baffle Filter.
	B. Baffle Filter not installed properly.	B. Reinstall Baffle Filter.
	C. Charcoal Filter missing.	C. Install Charcoal Filter.
FRYER WILL NOT HEAT: Power light on. Selector Switch in cook position. Heat light not on. Buzzer emitting a PULSATING Tone. (VH Model only)	A. EAC shorted or bent fins.	A. Repair EAC.
	B. EAC dirty.	B. Clean EAC.
	C. EAC Power Supply faulty.	C. Replace high voltage Power Supply
	D. EAC wires shorted.	D. Remove shorted condition.
	E. Bad Contact Plate.	E. Replace Contact Plate.
	F. EAC Module faulty.	F. Replace EAC Module.
FRYER WILL NOT HEAT: Power light on. Selector Switch in cook position. High Limit light On.	A. Power surge.	A. Turn Power Switch off for 5 seconds.
	B. Plug not completely in.	B. Reconnect to power source.
	C. Oil level too low.	C. Fill to kettle oil level mark.
	D. Sticking Contactor.	D. Replace Contactor.
	E. Bad High Limit Board.	E. Replace High Limit Board.
	F. High Limit Probe short or open.	F. Replace High Limit Probe.
	G. Line spikes or noise.	G. Filter Line or remove noise source.
FRYER WILL NOT HEAT: Power light on. Selector Switch in cook position. Heat light not on. Buzzer emitting a continuous tone. (VH Model only)	A. Charcoal Filter clogged.	A. Replace Charcoal Filter.
	B. Clogged Filter Switch bad.	B. Replace Clogged Filter Switch.
	C. Kinked Vacuum Line.	C. Remove Vacuum Line kinks.
	D. Fan running slow.	D. Check Voltage.
	E. Fan running slow.	E. Clean fan blades.

8-1. Temperature Control System (Continued)		
Problem	Probable Cause	Repair Procedure
FRYER HEAT SLOW: (slow recovery) Heat light stays on.	A. Incorrect Cooking procedures.	A. Consult Operations Manual for proper Cooking procedure.
	B. Element failing.	B. Replace bad Element.
	C. Contactor failing.	C. Replace Contactor.
	D. Loose Wire.	D. Repair Loose Wire.
	E. Low Supply Voltage.	E. Supply proper Voltage.
FRYER HEATS SLOW: (short cycling) Heat light off and on CONTINUOUSLY.	A. Low supply Voltage.	A. Supply proper Voltage.
	B. Variable probe touching element.	B. Reposition variable probe.
	C. Cooking Controller faulty.	C. Replace Cooking Controller.
OIL TEMPERATURE ERRATIC:	A. Probe bad.	A. Replace Probe.
	B. Contactor failing.	B. Replace Contactor.
	C. Cooking Controller faulty.	C. Replace Cooking Controller.
	D. Loose Wire.	D. Repair loose Wire.
OIL SMOKING:	A. Old Oil.	A. Change Oil.
	B. Over Temperature.	B. Check temperature setting.
	C. Dirty Element.	C. Clean Elements.
	D. Element failure.	D. Replace Element.
	E. Improper element voltage.	E. Supply proper Voltage.
	F. Low Oil level.	F. Keep Oil at FULL Level.

8-2. Oil Filtration System

Problem	Probable Cause	Repair Procedure
OIL NOT RETURNING TO FRY POT:	A. Cook/Filter Switch not in "Filter" position.	A. Place Selector Switch in "Filter" position.
	B. Air Leak (hose, fittings, filter paper).	B. Repair Air Leak.
	C. Pump Motor Bad.	C. Replace Pump Motor.
	D. Oil Pump Sticking.	D. Free Stuck Pump.
OIL PUMP STICKING	A. Boil Out being run through Pump.	A. Disassemble and Re-Oil Pump.
	B. Old Oil allowed to sit in Pump.	B. Run Clean Oil through Pump.

8-3. Basket Elevator System

BASKET WILL NOT GO UP OR DOWN:	A. Power not on.	A. Press Power Switch to ON position.
	B. Cooking Controller faulty.	B. Replace Cooking Controller.
	C. Cooking cycles running.	C. Cancel cooking cycle.
	D. Elevator microswitch out of adjustment.	D. Adjust Elevator microswitch.
	E. Elevator microswitch bad.	E. Replace Elevator microswitch.

8-4. Ultimate Ventless

UV LAMP NOT ILLUMINATED	A. Bad connection	A. Reconnect
	B. Lamp Blown	B. Replace Lamp
	C. Filters not installed correctly	C. Install Filters
	D. Filter Access cover not installed correctly	D. Install Filter Access Cover
	E. Bad Ballast	E. Replace Ballast

Parts List

Model: GEF-400, GEF-560, GEF-720 & GEF-400-VH, GEF-560-VH, GEF-720-VH

9. Parts List

This section lists various parts that are available for replacement on the GEF-400, GEF-560, GEF-720, GEF-400-VH, GEF-560-VH and GEF-720-VH.

9-1. Parts Ordering and Service Information

If you require assistance or need repairs, please contact your area developer for a service agency in your area. For further assistance, please contact the Giles Enterprises, Inc. corporate office:

US, CANADA or MEXICO Please call 1-800-288-1555 between 8:00AM-5:00PM Central Time Zone; during other than normal business hours, please call 1-800-288-1555, ask for Technical Service.

ALL OTHERS Please call 1-334-272-3528 between 8:00AM-5:00PM Central Time Zone; during other than normal business hours, please call 1-334-272-3528 extension 314.

INTERNET Please visit our website on the world wide web at: www.gilesent.com.

The goal of the Giles team of professionals is to provide you with the highest quality of service and assistance. You can help us accomplish this by obtaining the following information and having it readily available when calling. The information is recorded on the Data Plate attached to the rear of the unit.

MODEL	<input type="text"/>	SERIAL NO.	<input type="text"/>		
MODÈLE	<input type="text"/>	NO. DE SÉRIE	<input type="text"/>		
VAC	<input type="text"/>	AMP	<input type="text"/>	WATTS	<input type="text"/>
VCA	<input type="text"/>				
PHASE	<input type="text"/>	HZ.	<input type="text"/>	DATE	<input type="text"/>
<input type="text"/>					
GILES ENTERPRISES, INC.					
1-800-288-1555					
<small>64230-C</small>					

The area below may be helpful in recording information for use as a quick reference.

Model Number: _____

Serial Number: _____

Phase: _____

Voltage: _____

Nature of Problem: _____

9-2. Control Panel & Front Header

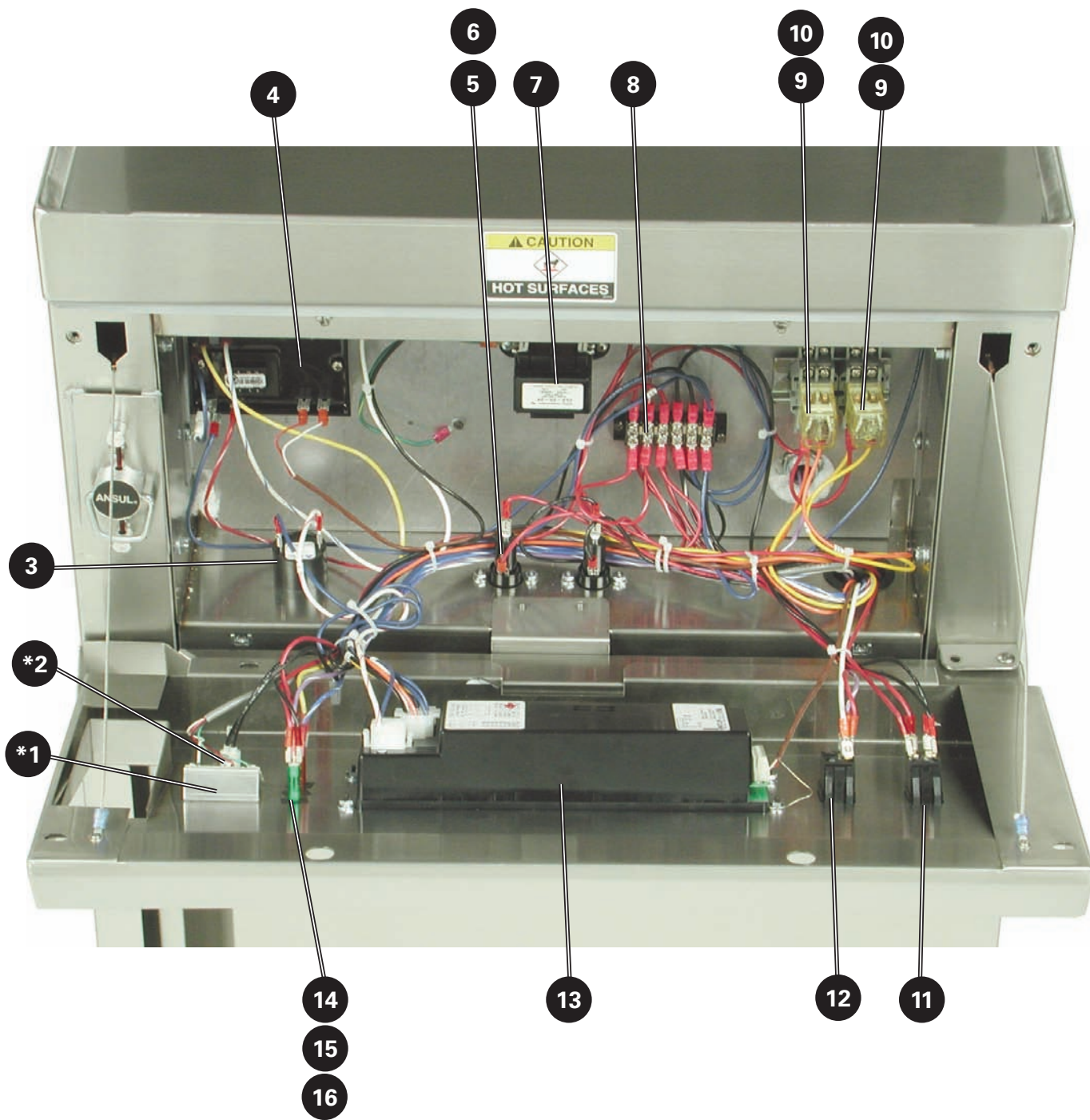

* -Ventless Hood Model only

Parts List

**Model: GEF-400, GEF-560, GEF-720 &
GEF-400-VH, GEF-560-VH, GEF-720-VH**

9-2. Control Panel & Front Header

Item	Part Number	QTY.	Description
*1	24209	1	LED, AIR FILTER, EAC
*2	22300	1	LIGHT, PILOT, 250V, ROUND, RED
3	22976	1	AUDIOLARM, BELL TIMER, CONTINUOUS,2-12DC
4	23754	1	THERMOSTAT,HILIMIT,WATLOW,425DEG,208/240
5	21950	2	HOLDER, FUSE, 300V, 15A, SC 0 TO 15
6	21900	2	FUSE, 15-AMP, SC-15
7	20366	1	TRANSFORMER, 20VA, 115/230V, 60HZ, CL2
8	23751	1	TERMINAL BLOCK, MA106
9	20312	1	BASE, RELAY, PLUG-IN, DIN MOUNT
10	20318	1	RELAY, 240 VAC, 10A, ELECTRO-MECH
11	21190	1	SWITCH, ROCKER, ON-OFF, 250V, 20A, D.P.
12	21189	1	SWITCH, ROCKER, ON-OFF-ON, 250V,20A,S.P.
13	24241	1	CONTROLLER, WATLOW, ENGLISH
14	38215	1	LIGHT, INDICATOR, GREEN, 250V
15	38213	1	LIGHT, INDICATOR, ORANGE, 250V
16	38214	1	LIGHT, INDICATOR, RED, 250V

* -Ventless Hood Model only

9-3. Front Lower Cabinet

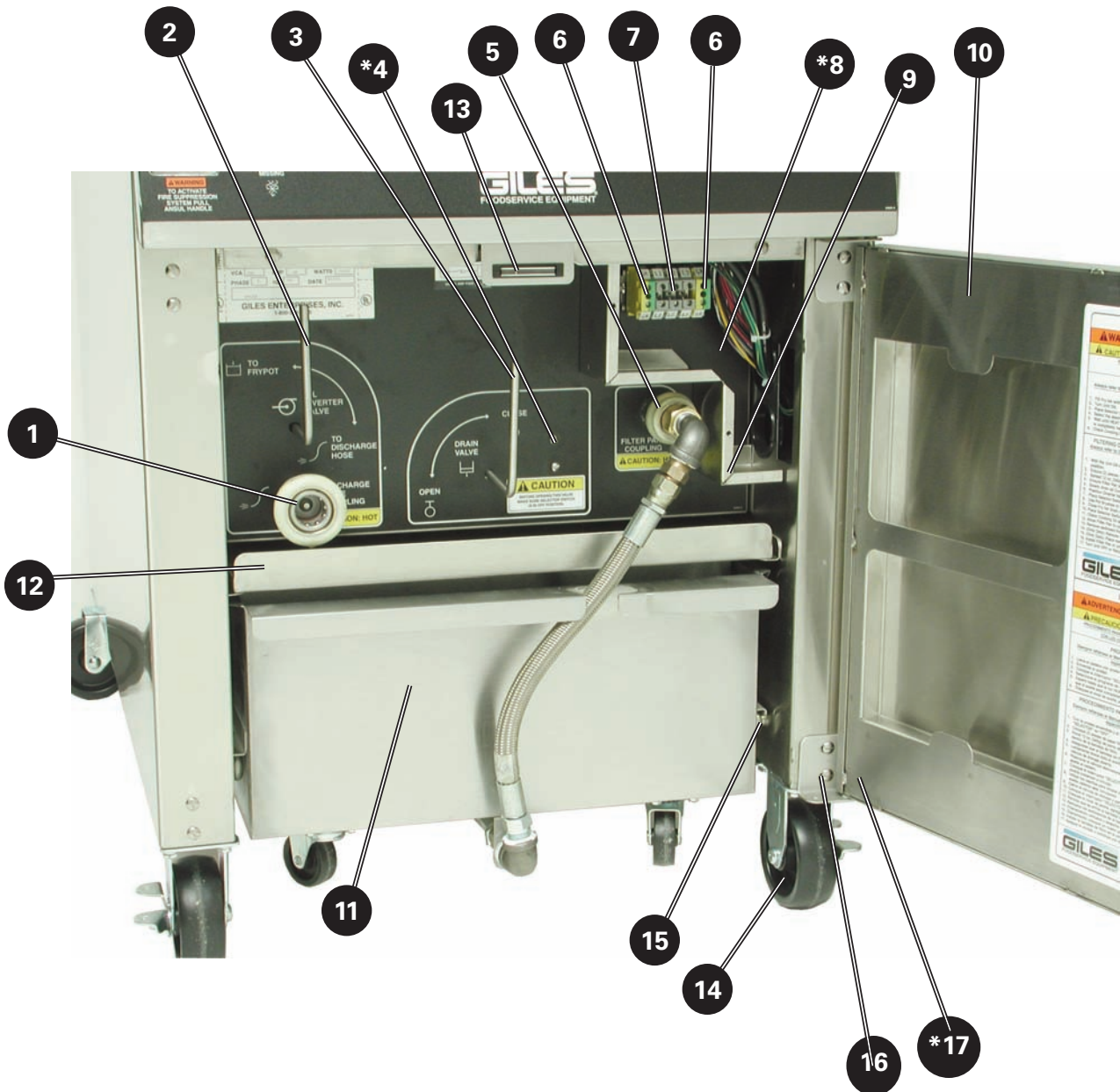

* -Not shown

Parts List

**Model: GEF-400, GEF-560, GEF-720 &
GEF-400-VH, GEF-560-VH, GEF-720-VH**

9-3. Front Lower Cabinet

Item	Part Number	Qty	Description
1	41699	1	COUPLING, QUICK DISCONNECT, FEMALE
2	38888	1	VALVE HANDLE, 3-WAY, WELD ASSY
3	38892	1	VALVE HANDLE, DRAIN, WELD ASSY, GEF
4	21157	1	SWITCH, LIMIT, 15A, 250V DRAIN SWITCH
5	41900	2	COUPLING, QUICK DICONNECT,FEMALE,FILTER PAN
6	20304	2	TERMINAL BLOCK, GROUND, 4-12 GA WIRE
7	20303	1	TERMINAL BLOCK, 4-12 GA WIRE
8	38881	1	COVER, SERVICE BOX
9	38880	1	SHROUD, SERVICE BOX
10	38845	1	DOOR, WELD ASSY, GEF-400/560/720
11	38834	1	FILTER PAN, ASSY, GEF-400/560/720
12	39044	1	FILTER PAN COVER, WELDMENT, GEF
13	40851	1	CATCH, MAGNET, DOOR, SNAP IN, 2.3IN
14	40806	1	CASTER, 5.000, RIGID, W/BRAKE, GEF
15	40315	1	BEARING, FILTR PAN LIFT
16	38869	2	BRACKET, DOOR, GEF
17	38951	2	PIN, DOOR HINGE, GEF-400/560/720

* -Not shown

9-4. Rear Lower Cabinet

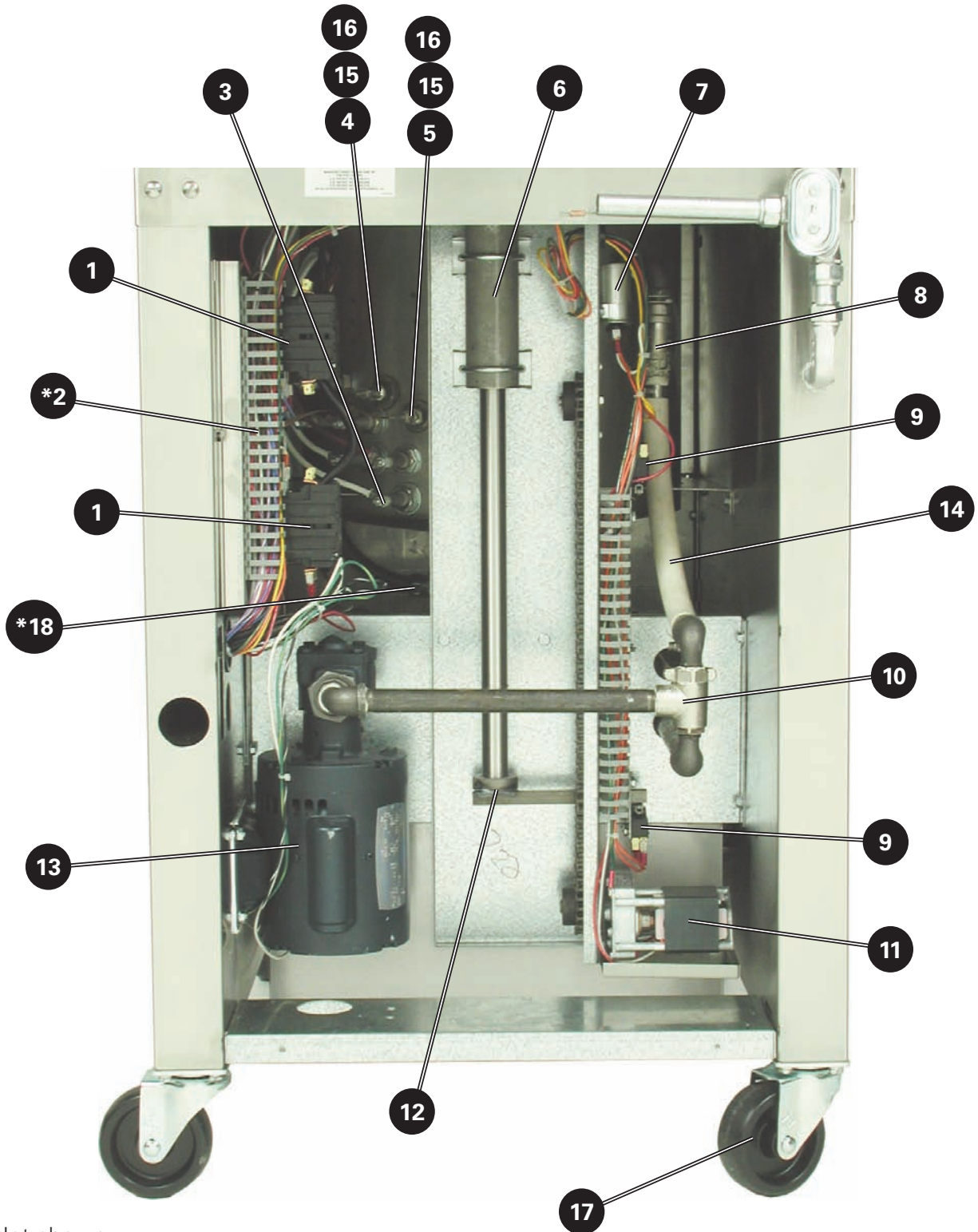

* -Not shown

Parts List

**Model: GEF-400, GEF-560, GEF-720 &
GEF-400-VH, GEF-560-VH, GEF-720-VH**

9-4. Rear Lower Cabinet

Item	Part Number	Qty.	Description
1	32208	2	CONTACTOR, ASSY, 208/240VAC, 3PH (GEF-400,560, 720 3PH)
1	32193	2	CONTACTOR, ASSY, 1 PH, 75A, 208/240V (GEF-560 1PH ONLY)
2	20513	1	BREAKER, CIRCUIT,277V,50A,6 PL, SER TRIP
3	20306	3	ELEMENT, 6666W, 208V, GEF-720
3	20309	3	ELEMENT, 6666W, 240V, GEF-720
3	20313	3	ELEMENT, 6666W, 480V, GEF-720
3	21526	3	ELEMENT, ROUND, 5000W, 208V, GEF-560
3	21299	3	ELEMENT, ROUND, 5000W, 240V, GEF-560
3	21527	3	ELEMENT, ROUND,3333W,208V, GEF-400
3	21298	3	ELEMENT, ROUND,3333W,240V, GEF-400
4**	23908	1	THERMOCOUPLE, SAFETY, TYPE J, SINGLE
5**	23909	1	THERMOCOUPLE, VARIABLE, TYPE J, SINGLE
6	40770	1	SHAFT & CYLINDER, ASSY, ELEVATOR, GEF
7	20122	1	CAPACITOR, 4mfds,370V,GEF
8	46712	1	VALVE, CHECK, 1/2 NPT
9	23201	2	SWITCH, SNAP ACTION, ROLLER TYPE
10	45755	1	VALVE, 3-WAY, 1/2NPT, NICKEL PLATED
11	20120	1	MOTOR, 230V, ELEVATOR,GEF
12	38824	1	ELEVATOR CARRIER, WELD ASSY, GEF
13	70912	1	PUMP/MOTOR ASSY, VIKING
14	32142	1	HOSE, 22.5, WHITE, SWIVEL FITTINGS
15	45111	2	FERRULE, SWAGELOCK, GAS
16	45400	2	CONNECTOR, 0.190 ID, 1/4NPT, SWAGELOCK
17	40807	2	CASTER, 5.000, SWIVEL, W/O BRAKE, GEF
18*	45876	1	VALVE, 1-1/2 NPT, DRAIN,

* -Not shown

** - Must also replace ferrule

9-5. Basket Cover and Basket



* -Not shown

Parts List

Model: GEF-400, GEF-560, GEF-720 &
GEF-400-VH, GEF-560-VH, GEF-720-VH

9-5. Basket Cover and Basket

Item	Part Number	Qty.	Description
1	33883	1	BASKET COVER, ASSY, GEF560/GEF720
1	33884	1	BASKET COVER, ASSY, GEF400
2	38930	1	BASKET CARRIER, ASSY, GEF-560 & GEF-720
2	39165	1	BASKET CARRIER, ASSY, GEF-400 & VH
3	38924	1	BASKET, WELD ASSY, GEF720
3	33703	1	BASKET, STG-2, WELD ASSY, GEF-560
3	33718	1	BASKET, WELD ASSY, GEF400

* -Not shown

9-6. Filter Pan

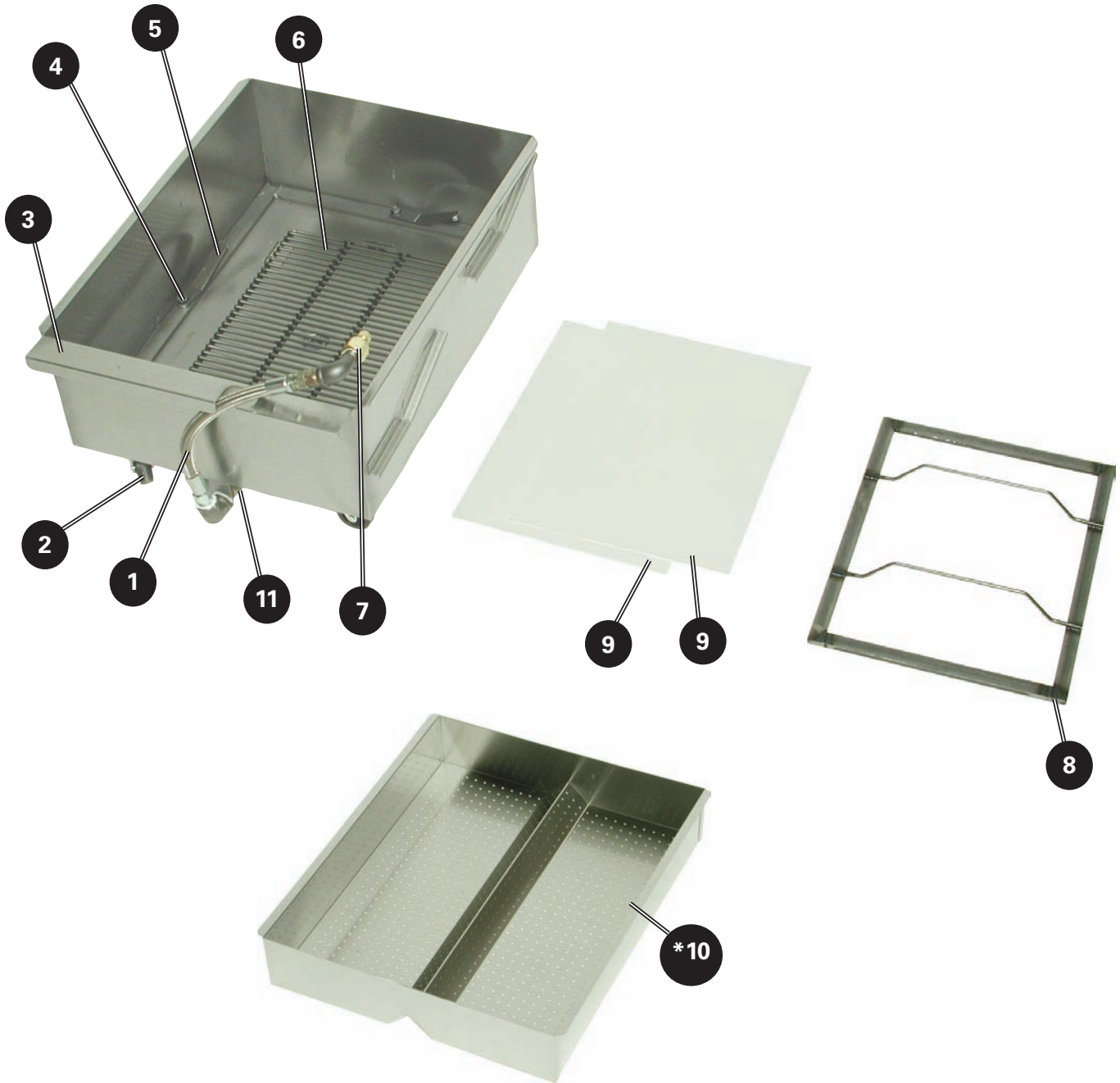

* -Accessory item, not included

Parts List

Model: GEF-400, GEF-560, GEF-720 &
GEF-400-VH, GEF-560-VH, GEF-720-VH

9-6. Filter Pan

Item	Part Number	Qty.	Description
1	40821	1	HOSE, 1/2NPT X 15.75, STEEL BRAIDED
2	40649	1	CASTER, SWIVEL, 2-9/16, FILTER PAN
3	38834	1	FILTER PAN, ASSY, GEF-400/560/720
4	30040-4	4	STUD, FILTER PAN HOLD DOWN FRAME
5	38841	4	HANDLE, SUPPORT FRAME, FILTER PAN, GEF
6	40771	1	SCREEN, FILTER PAN, GEF-400/560/720
7	44150	1	FITTING, BRASS,MALE,1/2NPT,QUICK DISCONNECT
8	38830	1	HOLD DOWN FRAME, WELD ASSY
9	60810	2	PAPER, FILTER, 21.375 X 15.500, GEF
10	39246	1	CRUMB SCREEN, FILTER PAN, WELD ASSY, GEF
11	40773	1	HOSE, 1/2NPT X 11.500, STEEL BRAIDED

* -Accessory item, not included

9-7. Front Ventless Hood



* -Not shown

** -UV Only

Parts List

Model: GEF-400, GEF-560, GEF-720 &
GEF-400-VH, GEF-560-VH, GEF-720-VH

9-7. Front Ventless Hood

Item	Part Number	Qty.	Description
*1	39041	1	HOOD FILTER ACCESS PANEL, ASSY
**1	90262	1	FILTER ACCESS PANEL, ASSY, UV HOOD
2	30248	1	CHARCOAL, FILTER ASSY, 20 x 12.375 x 2
3	20520	1	FILTER, EAC, 20 IN
4	42300	1	FILTER, BAFFLE, 20 X 20 X 2, SS
5	23200	1	SWITCH, SNAP ACTION, ROLLER TYPE
6	21125	1	BOARD, CONTACT, EAC, VH UNITS
7	30206	1	DRIP CUP, WELD ASSY
8	34750	1	PIN, DRIP CUP SAFETY
**9	90226	1	LAMP, ASSY, 16-IN, UV, REPLACEMENT ONLY

* -Not shown

** -UV Only

9-8. Rear Ventless Hood

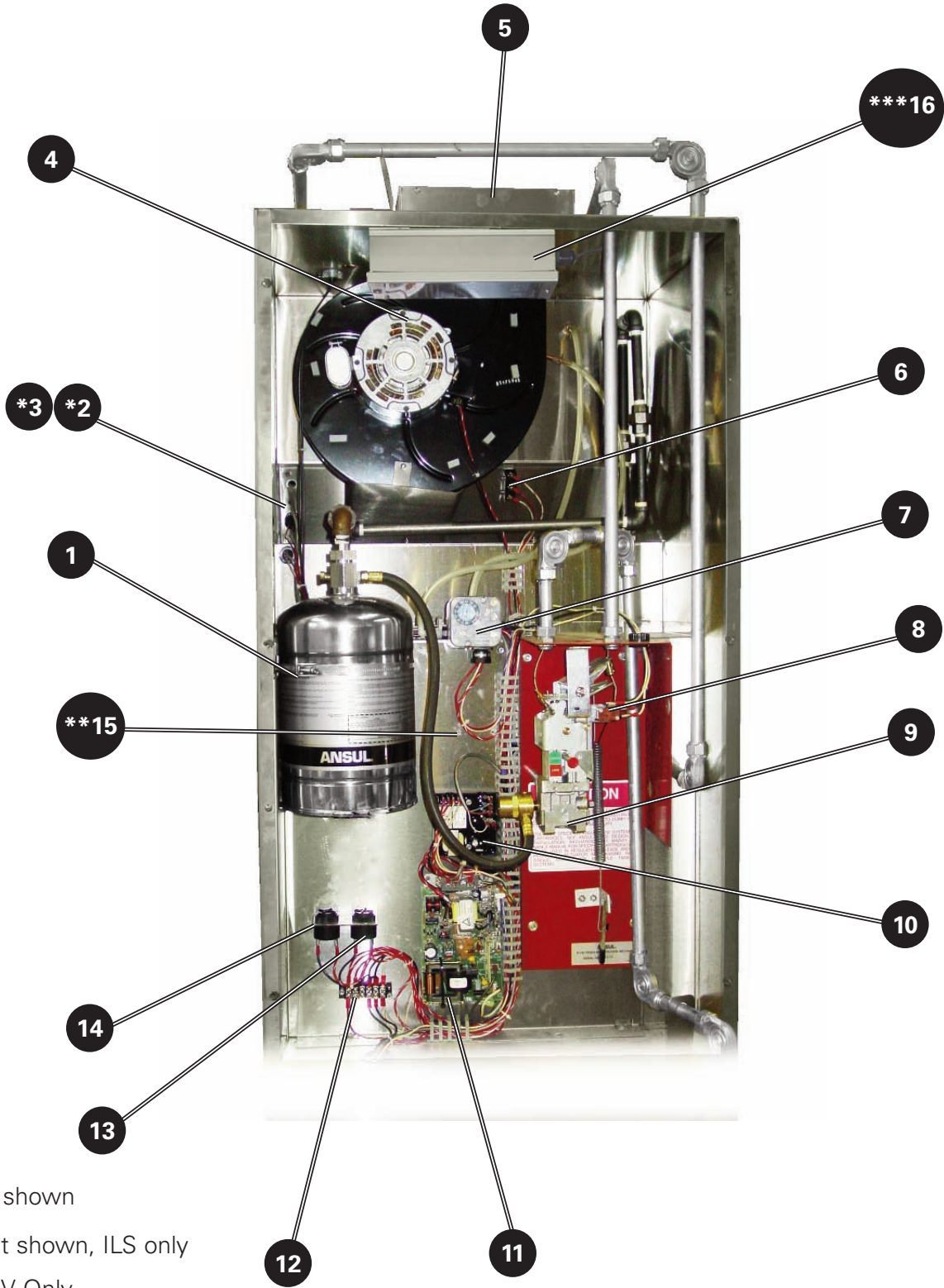

* -Not shown

** -Not shown, ILS only

*** -UV Only

Parts List

**Model: GEF-400, GEF-560, GEF-720 &
GEF-400-VH, GEF-560-VH, GEF-720-VH**

9-8. Rear Ventless Hood

Item	Part Number	Qty.	Description
1	39272	1	ASSY, TANK & LABEL, 1.5-GAL, S/S, ANSUL
*2	23778	1	SWITCH, SIDE ROTARY, 240V, 30A, W/O ARM
*3	23779	1	ROD, ADJUSTMENT
4	33589	1	BLOWER, ASSY, VH-FRYERS
5	46125	1	DAMPER, FIRE, 10 X 10, 285 DEG LINK
6	24237	1	SWITCH, PLUNGER, 250V, 15A
7	20390	1	SWITCH, VACUUM, ADJUSTABLE
8	20002	1	SWITCH, ANSUL, SHUTDOWN/ALARM, 15A, 120V
9	40132	1	BRACKET & RELEASE, ANSUL
10	23776	1	MODULE, AIR FILTER, ALARM & SHUTDOWN
11	24208	1	POWER SUPPLY, EAC, W/DRIVER, 208-240V
12	23751	1	TERMINAL BLOCK, MA106
13	23782	1	SONALERT, 250V, CONTINUOUS BEEP
14	22950	1	SONALERT, 250V, INTERMITTENT
**15	21191	1	RELAY, 30A, 208V, 2PL
**15	21174	1	RELAY, 30A, 240V, 2PL
***16	20373	1	UV-LAMP, ASSY (BALLAST AND LAMP)

* -Not shown

** -Not shown, ILS only

*** -UV Only

**Model: GEF-400, GEF-560, GEF-720 &
GEF-400-VH, GEF-560-VH, GEF-720-VH**

Parts List



Notes:

Wiring Diagram

Model: GEF-400, GEF-560, GEF-720 &
GEF-400-VH, GEF-560-VH, GEF-720-VH

10. Wiring Diagram

The following section contains various Wiring Diagrams for the GEF series. Please check the Serial Plate, as shown below, for the units Model Name, Voltage, Hertz, and Phase.

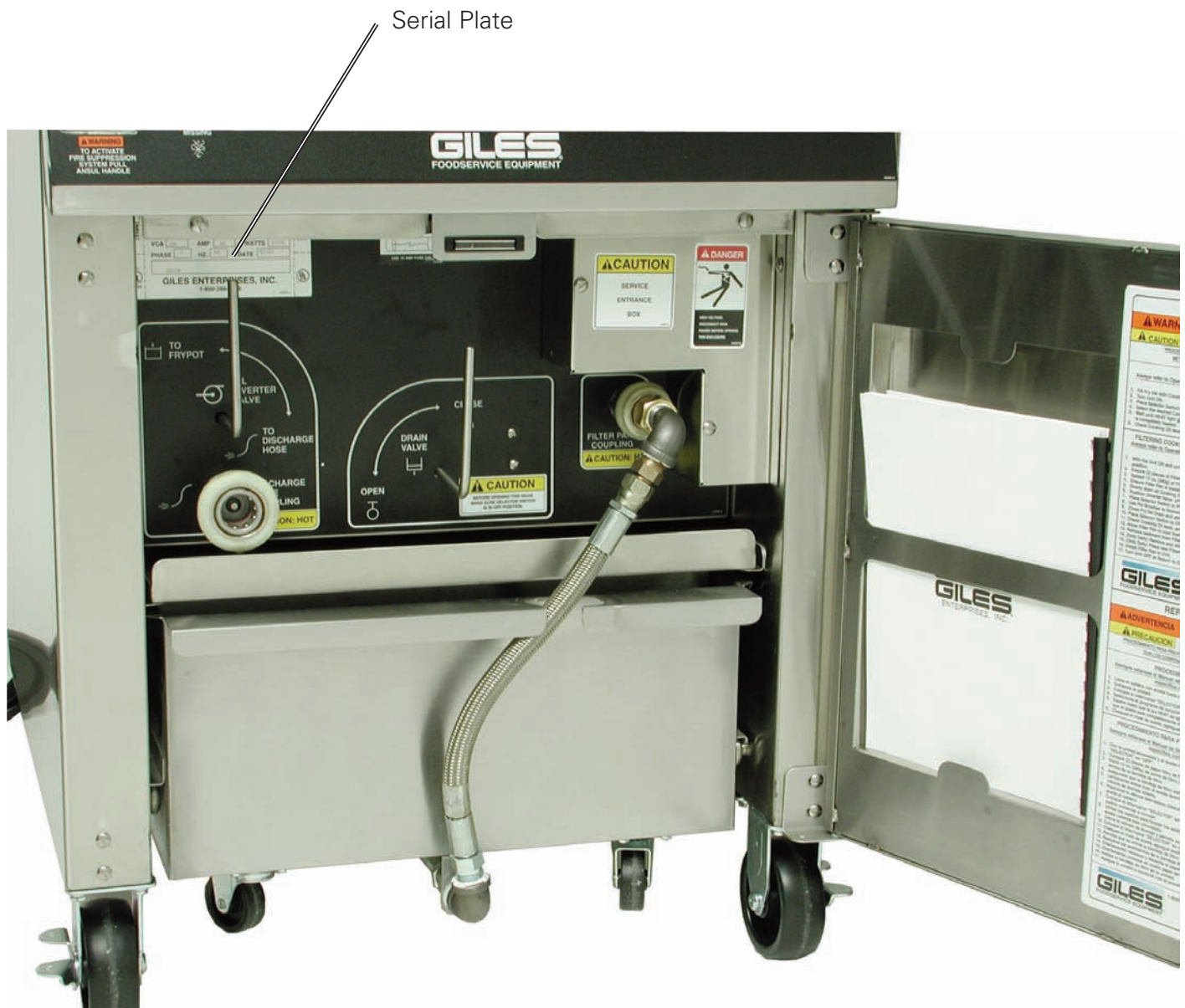

10-01. Wiring Diagram GEF-400 208-240/60/1 Computer

WIRING DIAGRAM GEF-400 208-240/60/1 DIGITAL TIMER/TEMP CONTROL (COMPUTER)

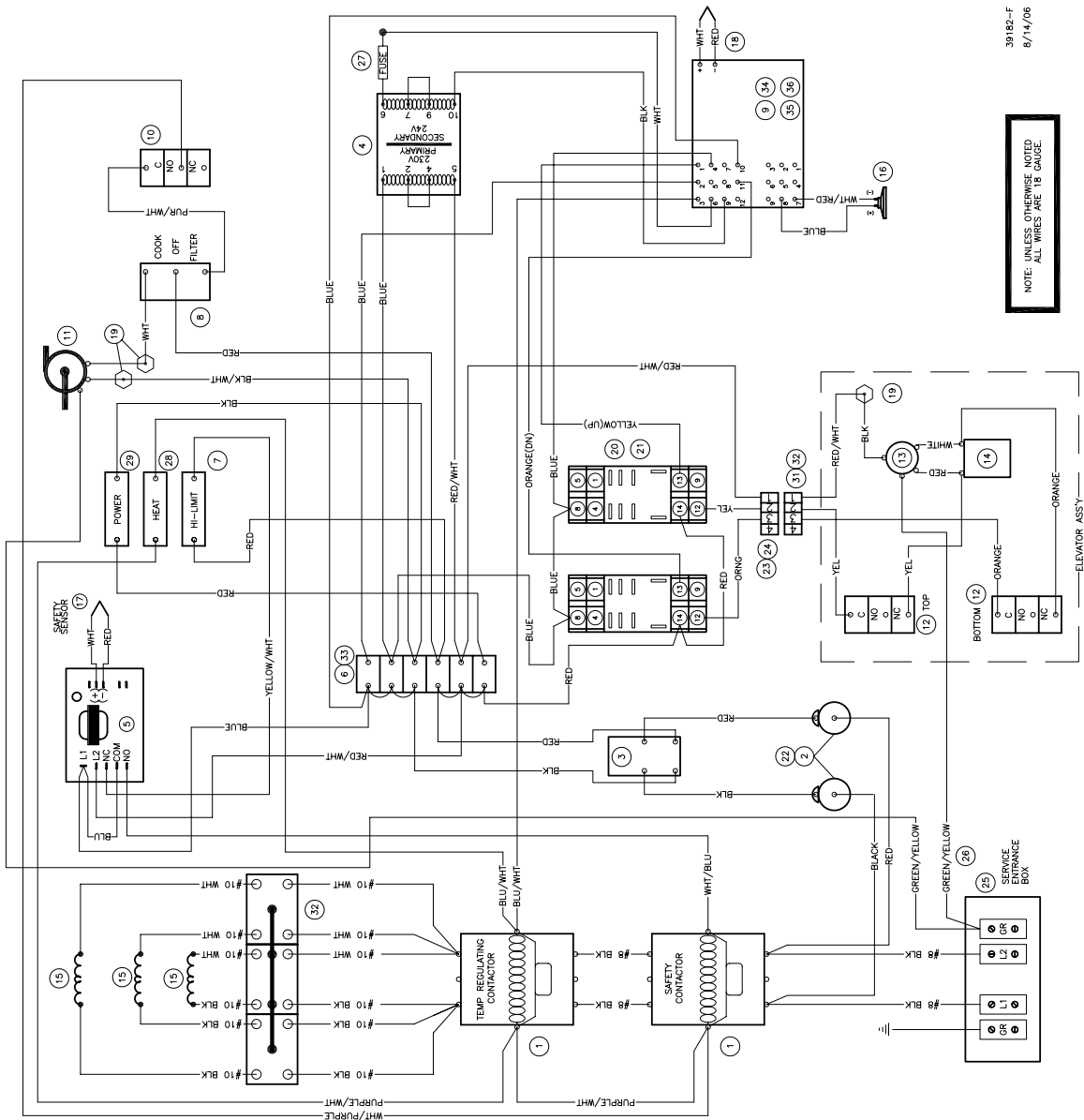

39182-F
8/14/06

NOTE: UNLESS OTHERWISE NOTED
ALL WIRES ARE 18 GAUGE

* A GREEN/YELLOW GND. STRAP MUST BE CONNECTED BETWEEN THE PART AND THE UNIT'S CHASSIS.

Wiring Diagram

**Model: GEF-400, GEF-560, GEF-720 &
GEF-400-VH, GEF-560-VH, GEF-720-VH**

10-01. BOM for Wiring Diagram GEF-400 208-240/60/1

Item	Part Number	Qty.	Description
1	32208	2	CONTACTOR, ASSY, 208/240VAC, 3PH
2	21950	2	HOLDER, FUSE, 300V, 15A, SC 0 TO 15
3	21190	1	SWITCH, ROCKER, ON-OFF, 250V, 20A, D.P.
4	20366	1	TRANSFORMER, 20VA, 115/230V, 60HZ, CL2
4	20217	1	TRANSFORMER,25VA,A41,115/230V,50HZ
5	23754	1	THERMOSTAT,HILIMIT,WATLOW,425DEG
6	23751	1	TERMINAL BLOCK, MA106
7	38214	1	LIGHT, INDICATOR, RED, 250V
8	21189	1	SWITCH, ROCKER, ON-OFF-ON, 250V,20A,S.P.
9	24241	1	CONTROLLER, WATLOW, ENGLISH
10	21157	1	SWITCH, LIMIT, 15A, 250V DRAIN SWITCH
11	70912	1	PUMP/MOTOR ASSY, VIKING
12	23201	2	SWITCH, SNAP ACTION, ROLLER TYPE
13	20120	1	MOTOR, 230V, ELEVATOR,GEF
14	20122	1	CAPACITOR, 4mfs,370V, GEF
15	21298	3	ELEMENT, ROUND,3333W,240V, GEF-400
15	21527	3	ELEMENT, ROUND,3333W,208V,GEF-400
16	22976	1	AUDIOLARM, BELL TIMER, CONTINUOUS,2-12DC
17	23908	1	THERMOCOUPLE, SAFETY, TYPE J, SINGLE
18	23909	1	THERMOCOUPLE, VARIABLE, TYPE J, SINGLE
19	25275	3	WIRENUT, BLUE
20	20312	2	BASE, RELAY, PLUG-IN, DIN MOUNT
21	20318	2	RELAY, 240 VAC, 10A, ELECTRO-MECH
22	21900	2	FUSE, 15-AMP, SC-15
23	20007	1	CONNECTOR, 4-PIN, IN-LINE RECEPTACLE
24	21291	3	CONNECTOR, PIN, FEMALE
25	20304	2	TERMINAL BLOCK, GROUND, 4-12 GA WIRE
26	20303	3	TERMINAL BLOCK, 4-12 GA WIRE
27	38365	1	ASSY, FUSE, CONTROLLER TRANSFORMER
28	38213	1	LIGHT, INDICATOR, ORANGE, 250V
29	38215	1	LIGHT, INDICATOR, GREEN, 250V
30	20008	1	CONNECTOR, 4-PIN, IN-LINE PLUG
31	21290	1	CONNECTOR, PIN, MALE
32	20513	1	BREAKER, CIRCUIT,277V,50A,6 PL, SER TRIP
33	21196	4	TERMINAL, BLOCK, JUMPER
34	21288	1	CONNECTOR, 9 PIN, AMP
35	21289	1	CONNECTOR, 12 PIN, AMP
36	21290	10	CONNECTOR, PIN, MALE

10-02. Wiring Diagram GEF-400 208-240/60/3 or 220/50/3 Computer

WIRING DIAGRAM GEF-400 208-240/60/3 AND 220/50/3 DIGITAL TIMER/TEMP CONTROL (COMPUTER)

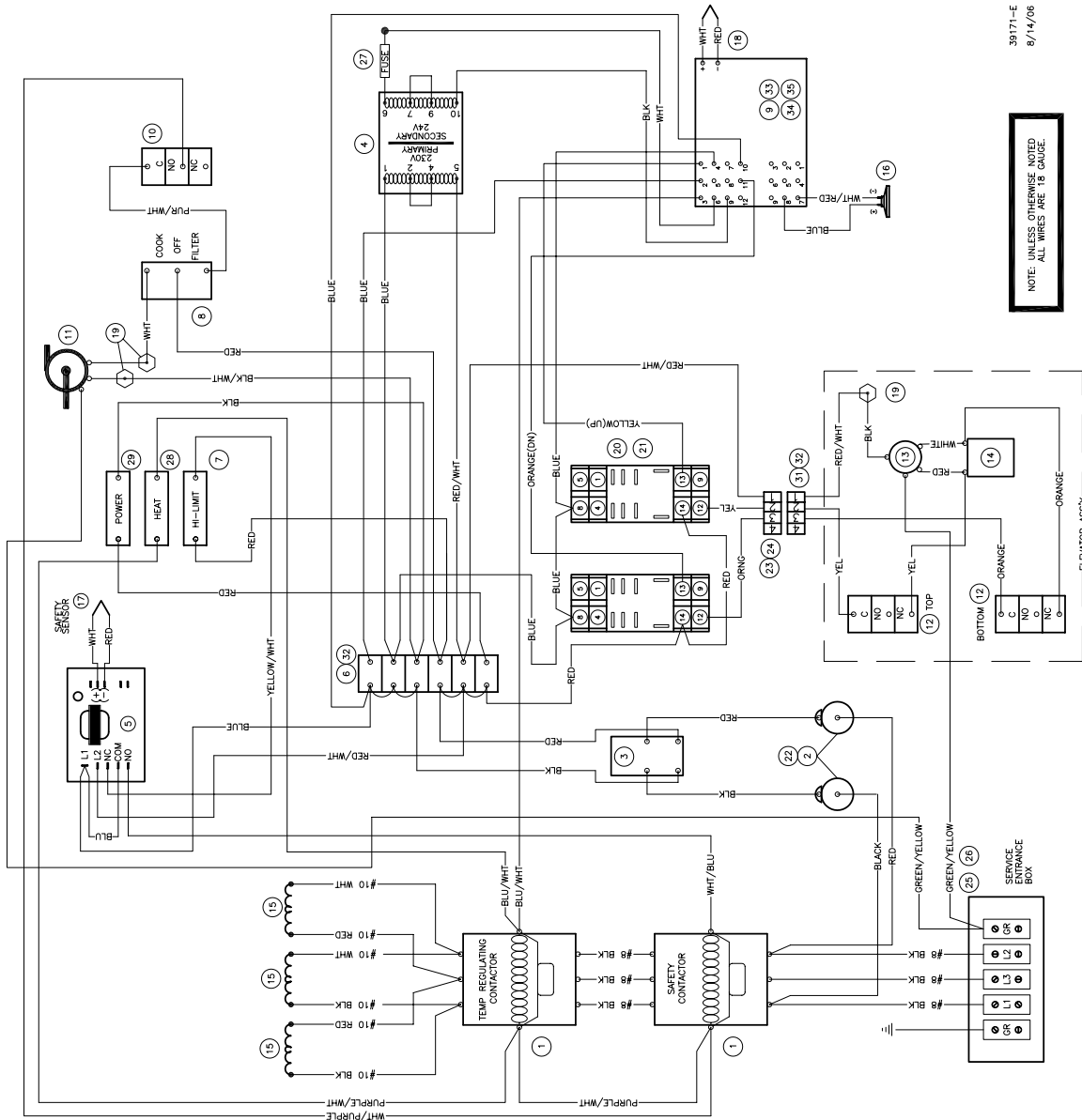

39171-E
8/14/06

NOTE: UNLESS OTHERWISE NOTED
ALL WIRES ARE 18 GAUGE.

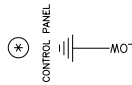
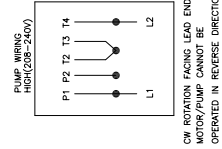

* A GREEN/YELLOW GND STRAP MUST BE CONNECTED BETWEEN THE PART AND THE UNIT'S CHASSIS.

WIRING DIAGRAM P/N:
39171-E

Wiring Diagram

Model: GEF-400, GEF-560, GEF-720 &
GEF-400-VH, GEF-560-VH, GEF-720-VH

10-02. BOM for Wiring Diagram GEF-400 208-240/60/3 or 220/50/3

Item	Part Number	Qty.	Description
1	32208	2	CONTACTOR, ASSY, 208/240VAC, 3PH
2	21950	2	HOLDER, FUSE, 300V, 15A, SC 0 TO 15
3	21190	1	SWITCH, ROCKER, ON-OFF, 250V, 20A, D.P.
4	20366	1	TRANSFORMER, 20VA, 115/230V, 60HZ, CL2
4	20217	1	TRANSFORMER, 25VA, A41, 115/230V, 50HZ
5	23754	1	THERMOSTAT, HILIMIT, WATLOW, 425DEG
6	23751	1	TERMINAL BLOCK, MA106
7	38214	1	LIGHT, INDICATOR, RED, 250V
8	21189	1	SWITCH, ROCKER, ON-OFF-ON, 250V, 20A, S.P.
9	24241	1	CONTROLLER, WATLOW, ENGLISH
10	21157	1	SWITCH, LIMIT, 15A, 250V DRAIN SWITCH
11	70912	1	PUMP/MOTOR ASSY, VIKING
12	23201	2	SWITCH, SNAP ACTION, ROLLER TYPE
13	20120	1	MOTOR, 230V, ELEVATOR, GEF
14	20122	1	CAPACITOR, 4mfd, 370V, GEF
15	21298	3	ELEMENT, ROUND, 3333W, 240V, GEF-400
15	21527	3	ELEMENT, ROUND, 3333W, 208V, GEF-400
16	22976	1	AUDIOLARM, BELL TIMER, CONTINUOUS, 2-12DC
17	23908	1	THERMOCOUPLE, SAFETY, TYPE J, SINGLE
18	23909	1	THERMOCOUPLE, VARIABLE, TYPE J, SINGLE
19	25275	3	WIRENUT, BLUE
20	20312	2	BASE, RELAY, PLUG-IN, DIN MOUNT
21	20318	2	RELAY, 240 VAC, 10A, ELECTRO-MECH
22	21900	2	FUSE, 15-AMP, SC-15
23	20007	1	CONNECTOR, 4-PIN, IN-LINE RECEPTACLE
24	21291	3	CONNECTOR, PIN, FEMALE
25	20304	2	TERMINAL BLOCK, GROUND, 4-12 GA WIRE
26	20303	3	TERMINAL BLOCK, 4-12 GA WIRE
27	38365	1	ASSY, FUSE, CONTROLLER TRANSFORMER
28	38213	1	LIGHT, INDICATOR, ORANGE, 250V
29	38215	1	LIGHT, INDICATOR, GREEN, 250V
30	20008	1	CONNECTOR, 4-PIN, IN-LINE PLUG
31	21290	1	CONNECTOR, PIN, MALE
32	21196	4	TERMINAL, BLOCK, JUMPER
33	21288	1	CONNECTOR, 9 PIN, AMP
34	21289	1	CONNECTOR, 12 PIN, AMP
35	21290	10	CONNECTOR, PIN, MALE

10-03. Wiring Diagram GEF-560 208-240/60/1 Computer

WIRING DIAGRAM GEF-560 208-240/60/1 DIGITAL TIMER/TEMP CONTROL (COMPUTER)

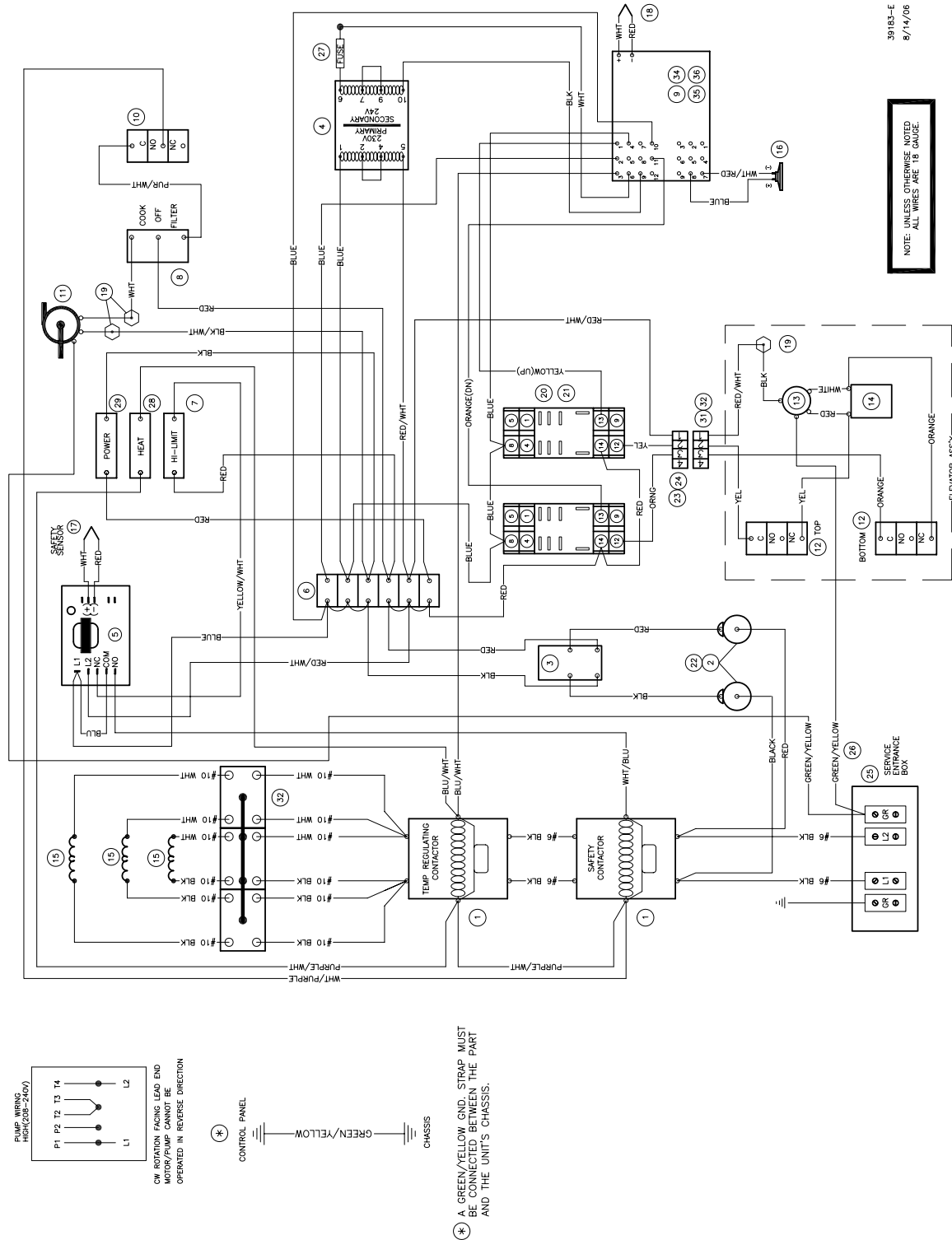

Wiring Diagram

**Model: GEF-400, GEF-560, GEF-720 &
GEF-400-VH, GEF-560-VH, GEF-720-VH**

10-03. BOM for Wiring Diagram GEF-560 208-240/60/1

Item	Part Number	Qty.	Description
1	32208	2	CONTACTOR, ASSY, 208/240VAC, 3PH
2	21950	2	HOLDER, FUSE, 300V, 15A, SC 0 TO 15
3	21190	1	SWITCH, ROCKER, ON-OFF, 250V, 20A, D.P.
4	20366	1	TRANSFORMER, 20VA, 115/230V, 60HZ, CL2
4	20217	1	TRANSFORMER, 25VA, A41, 115/230V, 50HZ
5	23754	1	THERMOSTAT, HILIMIT, WATLOW, 425DEG
6	23751	1	TERMINAL BLOCK, MA106
7	38214	1	LIGHT, INDICATOR, RED, 250V
8	21189	1	SWITCH, ROCKER, ON-OFF-ON, 250V, 20A, S.P.
9	24241	1	CONTROLLER, WATLOW, ENGLISH
10	21157	1	SWITCH, LIMIT, 15A, 250V DRAIN SWITCH
11	70912	1	PUMP/MOTOR ASSY, VIKING
12	23201	2	SWITCH, SNAP ACTION, ROLLER TYPE
13	20120	1	MOTOR, 230V, ELEVATOR, GEF
14	20122	1	CAPACITOR, 4mfd, 370V, GEF
15	21526	3	ELEMENT, ROUND, 5000W, 208V, GEF-560
15	21299	3	ELEMENT, ROUND, 5000W, 240V, GEF-560
16	22976	1	AUDIOLARM, BELL TIMER, CONTINUOUS, 2-12DC
17	23908	1	THERMOCOUPLE, SAFETY, TYPE J, SINGLE
18	23909	1	THERMOCOUPLE, VARIABLE, TYPE J, SINGLE
19	25275	3	WIRENUT, BLUE
20	20312	2	BASE, RELAY, PLUG-IN, DIN MOUNT
21	20318	2	RELAY, 240 VAC, 10A, ELECTRO-MECH
22	21900	2	FUSE, 15-AMP, SC-15
23	20007	1	CONNECTOR, 4-PIN, IN-LINE RECEPTACLE
24	21291	3	CONNECTOR, PIN, FEMALE
25	20304	2	TERMINAL BLOCK, GROUND, 4-12 GA WIRE
26	20303	3	TERMINAL BLOCK, 4-12 GA WIRE
27	38365	1	ASSY, FUSE, CONTROLLER TRANSFORMER
28	38213	1	LIGHT, INDICATOR, ORANGE, 250V
29	38215	1	LIGHT, INDICATOR, GREEN, 250V
30	20008	1	CONNECTOR, 4-PIN, IN-LINE PLUG
31	21290	1	CONNECTOR, PIN, MALE
32	20513	1	BREAKER, CIRCUIT, 277V, 50A, 6 PL, SER TRIP
33	21196	4	TERMINAL, BLOCK, JUMPER
34	21288	1	CONNECTOR, 9 PIN, AMP
35	21289	1	CONNECTOR, 12 PIN, AMP
36	21290	10	CONNECTOR, PIN, MALE

10-04. Wiring Diagram GEF-560 208-240/60/3 or 220/50/3 Computer

WIRING DIAGRAM GEF-560 208-240/60/3 AND 220/50/3 DIGITAL TIMER/TEMP CONTROL (COMPUTER)

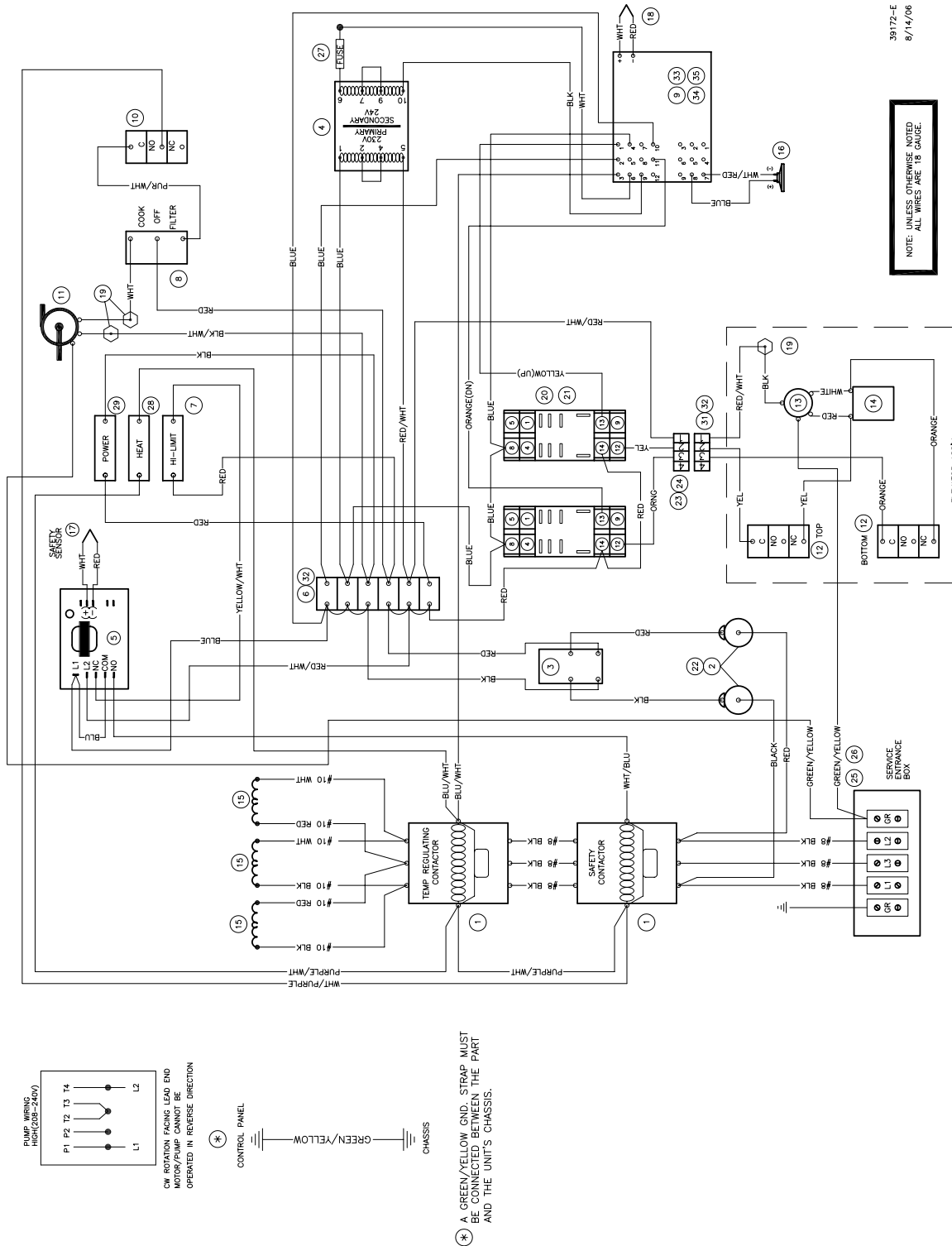

Wiring Diagram

**Model: GEF-400, GEF-560, GEF-720 &
GEF-400-VH, GEF-560-VH, GEF-720-VH**

10-04. BOM for Wiring Diagram GEF-560 208-240/60/3 or 220/50/3

Item	Part Number	Qty.	Description
1	32208	2	CONTACTOR, ASSY, 208/240VAC, 3PH
2	21950	2	HOLDER, FUSE, 300V, 15A, SC 0 TO 15
3	21190	1	SWITCH, ROCKER, ON-OFF, 250V, 20A, D.P.
4	20366	1	TRANSFORMER, 20VA, 115/230V, 60HZ, CL2
4	20217	1	TRANSFORMER,25VA,A41,115/230V,50HZ
5	23754	1	THERMOSTAT,HILIMIT,WATLOW,425DEG
6	23751	1	TERMINAL BLOCK, MA106
7	38214	1	LIGHT, INDICATOR, RED, 250V
8	21189	1	SWITCH, ROCKER, ON-OFF-ON, 250V,20A,S.P.
9	24241	1	CONTROLLER, WATLOW, ENGLISH
10	21157	1	SWITCH, LIMIT, 15A, 250V DRAIN SWITCH
11	70912	1	PUMP/MOTOR ASSY, VIKING
12	23201	2	SWITCH, SNAP ACTION, ROLLER TYPE
13	20120	1	MOTOR, 230V, ELEVATOR,GEF
14	20122	1	CAPACITOR, 4mfds,370V, GEF
15	21526	3	ELEMENT, ROUND, 5000W, 208V, GEF-560
15	21299	3	ELEMENT, ROUND, 5000W, 240V, GEF-560
16	22976	1	AUDIOLARM, BELL TIMER, CONTINUOUS,2-12DC
17	23908	1	THERMOCOUPLE, SAFETY, TYPE J, SINGLE
18	23909	1	THERMOCOUPLE, VARIABLE, TYPE J, SINGLE
19	25275	3	WIRENUT, BLUE
20	20312	2	BASE, RELAY, PLUG-IN, DIN MOUNT
21	20318	2	RELAY, 240 VAC, 10A, ELECTRO-MECH
22	21900	2	FUSE, 15-AMP, SC-15
23	20007	1	CONNECTOR, 4-PIN, IN-LINE RECEPTACLE
24	21291	3	CONNECTOR, PIN, FEMALE
25	20304	2	TERMINAL BLOCK, GROUND, 4-12 GA WIRE
26	20303	3	TERMINAL BLOCK, 4-12 GA WIRE
27	38365	1	ASSY, FUSE, CONTROLLER TRANSFORMER
28	38213	1	LIGHT, INDICATOR, ORANGE, 250V
29	38215	1	LIGHT, INDICATOR, GREEN, 250V
30	20008	1	CONNECTOR, 4-PIN, IN-LINE PLUG
31	21290	1	CONNECTOR, PIN, MALE
32	21196	4	TERMINAL, BLOCK, JUMPER
33	21288	1	CONNECTOR, 9 PIN, AMP
34	21289	1	CONNECTOR, 12 PIN, AMP
35	21290	10	CONNECTOR, PIN, MALE

10-05. Wiring Diagram GEF-720 208-240/60/3 or 220/50/3 Computer

WIRING DIAGRAM GEF-720 208-240/60/3 AND 220/50/3 DIGITAL TIMER/TEMP CONTROL (COMPUTER)

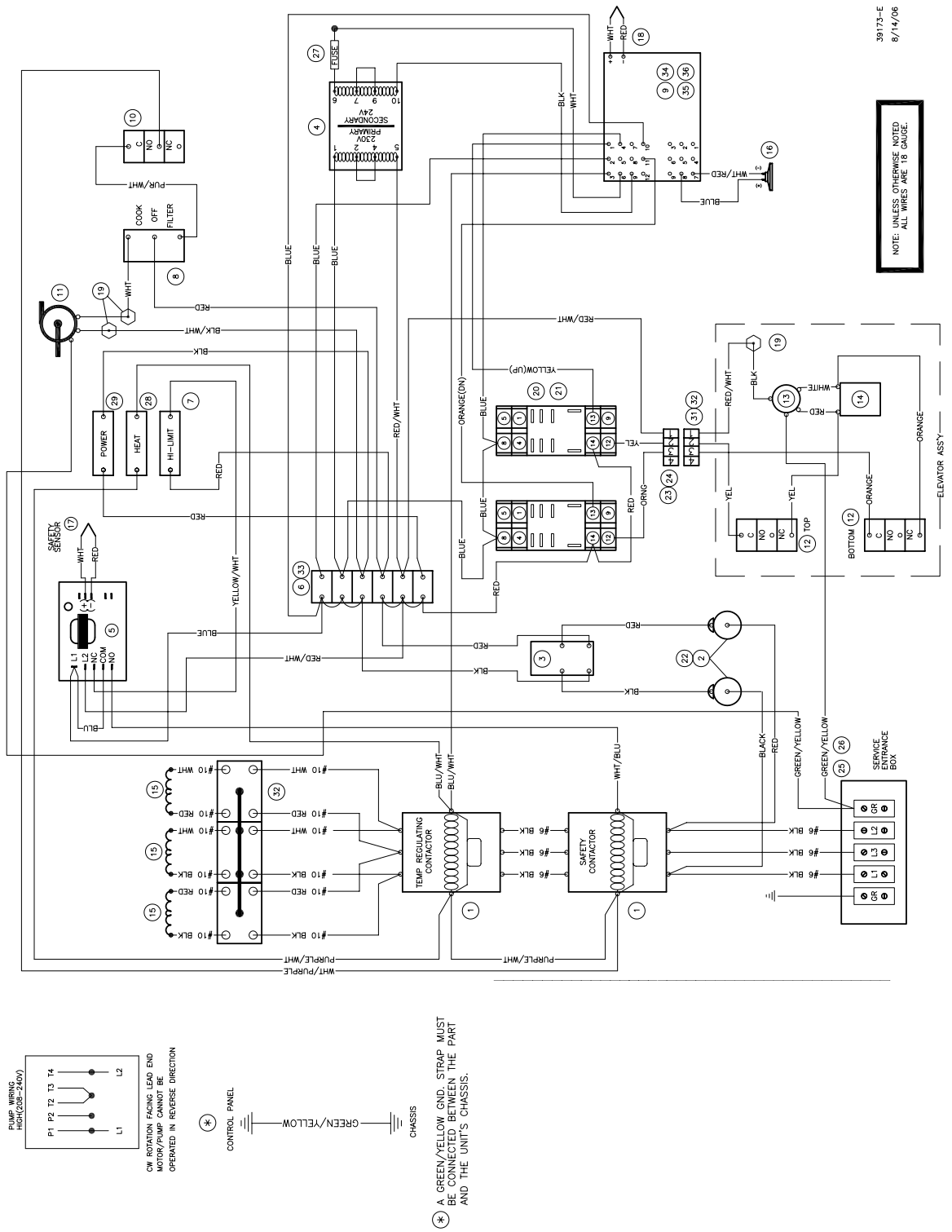

39173-E
8/14/06

Wiring Diagram

**Model: GEF-400, GEF-560, GEF-720 &
GEF-400-VH, GEF-560-VH, GEF-720-VH**

10-05. BOM for Wiring Diagram GEF-720 208-240/60/3 or 220/50/3

Item	Part Number	Qty.	Description
1	32208	2	CONTACTOR, ASSY, 208/240VAC, 3PH
2	21950	2	HOLDER, FUSE, 300V, 15A, SC 0 TO 15
3	21190	1	SWITCH, ROCKER, ON-OFF, 250V, 20A, D.P.
4	20366	1	TRANSFORMER, 20VA, 115/230V, 60HZ, CL2
4	20217	1	TRANSFORMER, 25VA, A41, 115/230V, 50HZ
5	23754	1	THERMOSTAT, HI LIMIT, WATLOW, 425 DEG
6	23751	1	TERMINAL BLOCK, MA106
7	38214	1	LIGHT, INDICATOR, RED, 250V
8	21189	1	SWITCH, ROCKER, ON-OFF-ON, 250V, 20A, S.P.
9	24241	1	CONTROLLER, WATLOW, ENGLISH
10	21157	1	SWITCH, LIMIT, 15A, 250V DRAIN SWITCH
11	70912	1	PUMP/MOTOR ASSY, VIKING
12	23201	2	SWITCH, SNAP ACTION, ROLLER TYPE
13	20120	1	MOTOR, 230V, ELEVATOR, GEF
14	20122	1	CAPACITOR, 4mfd, 370V, GEF
15	20306	3	ELEMENT, 6666W, 208V, GEF-720
15	20309	3	ELEMENT, 6666W, 240V, GEF-720
16	22976	1	AUDIOLARM, BELL TIMER, CONTINUOUS, 2-12DC
17	23908	1	THERMOCOUPLE, SAFETY, TYPE J, SINGLE
18	23909	1	THERMOCOUPLE, VARIABLE, TYPE J, SINGLE
19	25275	3	WIRENUT, BLUE
20	20312	2	BASE, RELAY, PLUG-IN, DIN MOUNT
21	20318	2	RELAY, 240 VAC, 10A, ELECTRO-MECH
22	21900	2	FUSE, 15-AMP, SC-15
23	20007	1	CONNECTOR, 4-PIN, IN-LINE RECEPTACLE
24	21291	3	CONNECTOR, PIN, FEMALE
25	20304	2	TERMINAL BLOCK, GROUND, 4-12 GA WIRE
26	20303	3	TERMINAL BLOCK, 4-12 GA WIRE
27	38365	1	ASSY, FUSE, CONTROLLER TRANSFORMER
28	38213	1	LIGHT, INDICATOR, ORANGE, 250V
29	38215	1	LIGHT, INDICATOR, GREEN, 250V
30	20008	1	CONNECTOR, 4-PIN, IN-LINE PLUG
31	21290	1	CONNECTOR, PIN, MALE
32	21196	4	TERMINAL, BLOCK, JUMPER
33	21288	1	CONNECTOR, 9 PIN, AMP
34	21289	1	CONNECTOR, 12 PIN, AMP
35	21290	10	CONNECTOR, PIN, MALE

10-06. Wiring Diagram GEF-720 480/60/3 Computer

WIRING DIAGRAM GEF-720 480/60/3 DIGITAL TIMER/TEMP CONTROL (COMPUTER)

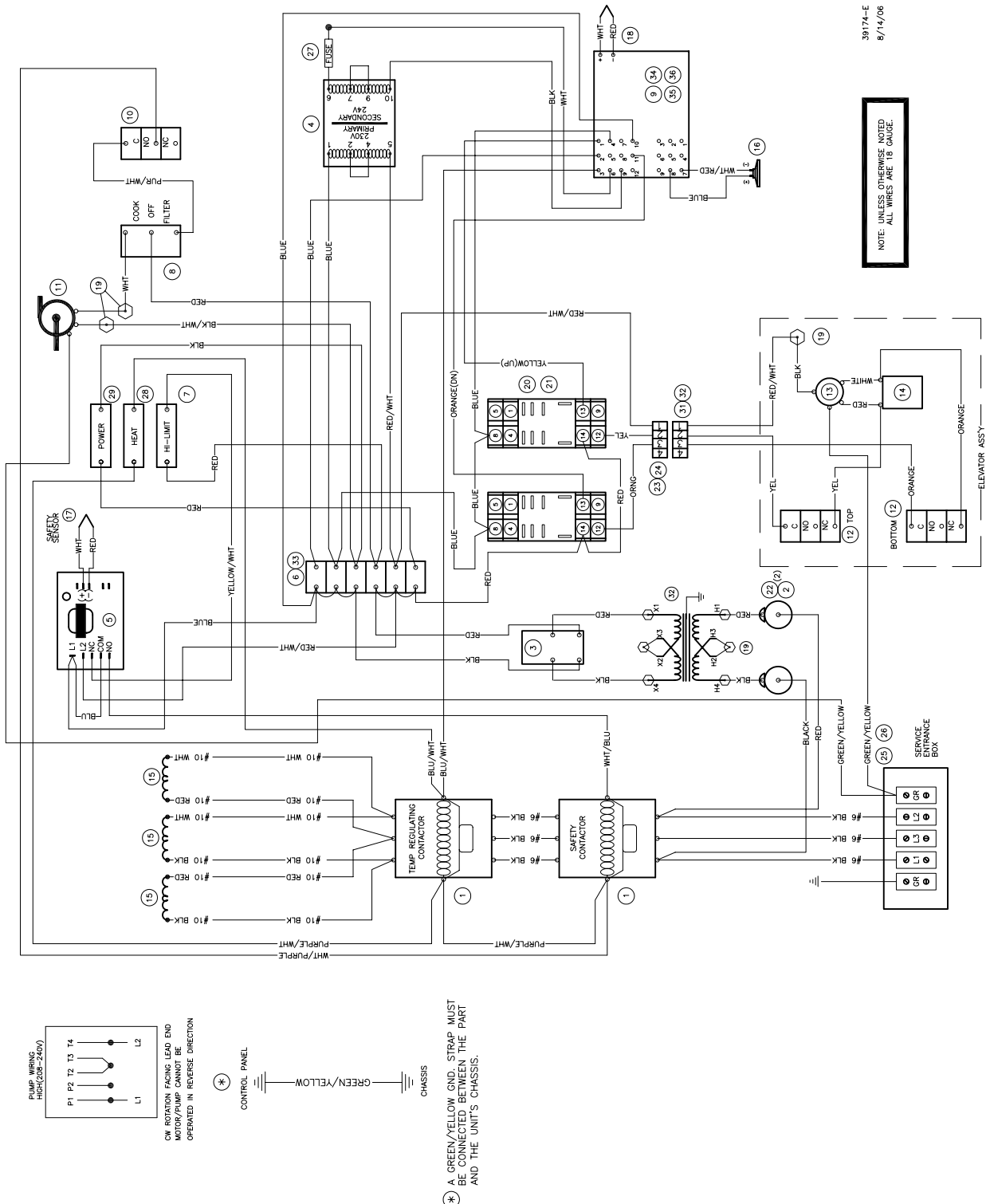

Wiring Diagram

**Model: GEF-400, GEF-560, GEF-720 &
GEF-400-VH, GEF-560-VH, GEF-720-VH**

10-06. BOM for Wiring Diagram GEF-720 480/60/3 Computer

Item	Part Number	Qty.	Description
1	32208	2	CONTACTOR, ASSY, 208/240VAC, 3PH
2	21950	2	HOLDER, FUSE, 300V, 15A, SC 0 TO 15
3	21190	1	SWITCH, ROCKER, ON-OFF, 250V, 20A, D.P.
4	20366	1	TRANSFORMER, 20VA, 115/230V, 60HZ, CL2
4	20217	1	TRANSFORMER,25VA,A41,115/230V,50HZ
5	23754	1	THERMOSTAT,HILIMIT,WATLOW,425DEG
6	23751	1	TERMINAL BLOCK, MA106
7	38214	1	LIGHT, INDICATOR, RED, 250V
8	21189	1	SWITCH, ROCKER, ON-OFF-ON, 250V,20A,S.P.
9	24241	1	CONTROLLER, WATLOW, ENGLISH
10	21157	1	SWITCH, LIMIT, 15A, 250V DRAIN SWITCH
11	70912	1	PUMP/MOTOR ASSY, VIKING
12	23201	2	SWITCH, SNAP ACTION, ROLLER TYPE
13	20120	1	MOTOR, 230V, ELEVATOR,GEF
14	20122	1	CAPACITOR, 4mfs,370V, GEF
15	20306	3	ELEMENT, 6666W, 208V, GEF-720
15	20309	3	ELEMENT, 6666W, 240V, GEF-720
16	22976	1	AUDIOLARM, BELL TIMER, CONTINUOUS,2-12DC
17	23908	1	THERMOCOUPLE, SAFETY, TYPE J, SINGLE
18	23909	1	THERMOCOUPLE, VARIABLE, TYPE J, SINGLE
19	25275	3	WIRENUT, BLUE
20	20312	2	BASE, RELAY, PLUG-IN, DIN MOUNT
21	20318	2	RELAY, 240 VAC, 10A, ELECTRO-MECH
22	21900	2	FUSE, 15-AMP, SC-15
23	20007	1	CONNECTOR, 4-PIN, IN-LINE RECEPTACLE
24	21291	3	CONNECTOR, PIN, FEMALE
25	20304	2	TERMINAL BLOCK, GROUND, 4-12 GA WIRE
26	20303	3	TERMINAL BLOCK, 4-12 GA WIRE
27	38365	1	ASSY, FUSE, CONTROLLER TRANSFORMER
28	38213	1	LIGHT, INDICATOR, ORANGE, 250V
29	38215	1	LIGHT, INDICATOR, GREEN, 250V
30	20008	1	CONNECTOR, 4-PIN, IN-LINE PLUG
31	21290	1	CONNECTOR, PIN, MALE
32	24277	1	TRANSFORMER, 1.5kw, 480V TO 240V
33	21196	4	TERMINAL, BLOCK, JUMPER
34	21288	1	CONNECTOR, 9 PIN, AMP
35	21289	1	CONNECTOR, 12 PIN, AMP
36	21290	10	CONNECTOR, PIN, MALE

10-07. Wiring Diagram GEF-400-VH 208-240/60/1 Computer

WIRING DIAGRAM GEF-400-VH 208-240/60/1 DIGITAL TIMER/TEMP CONTROL (COMPUTER)

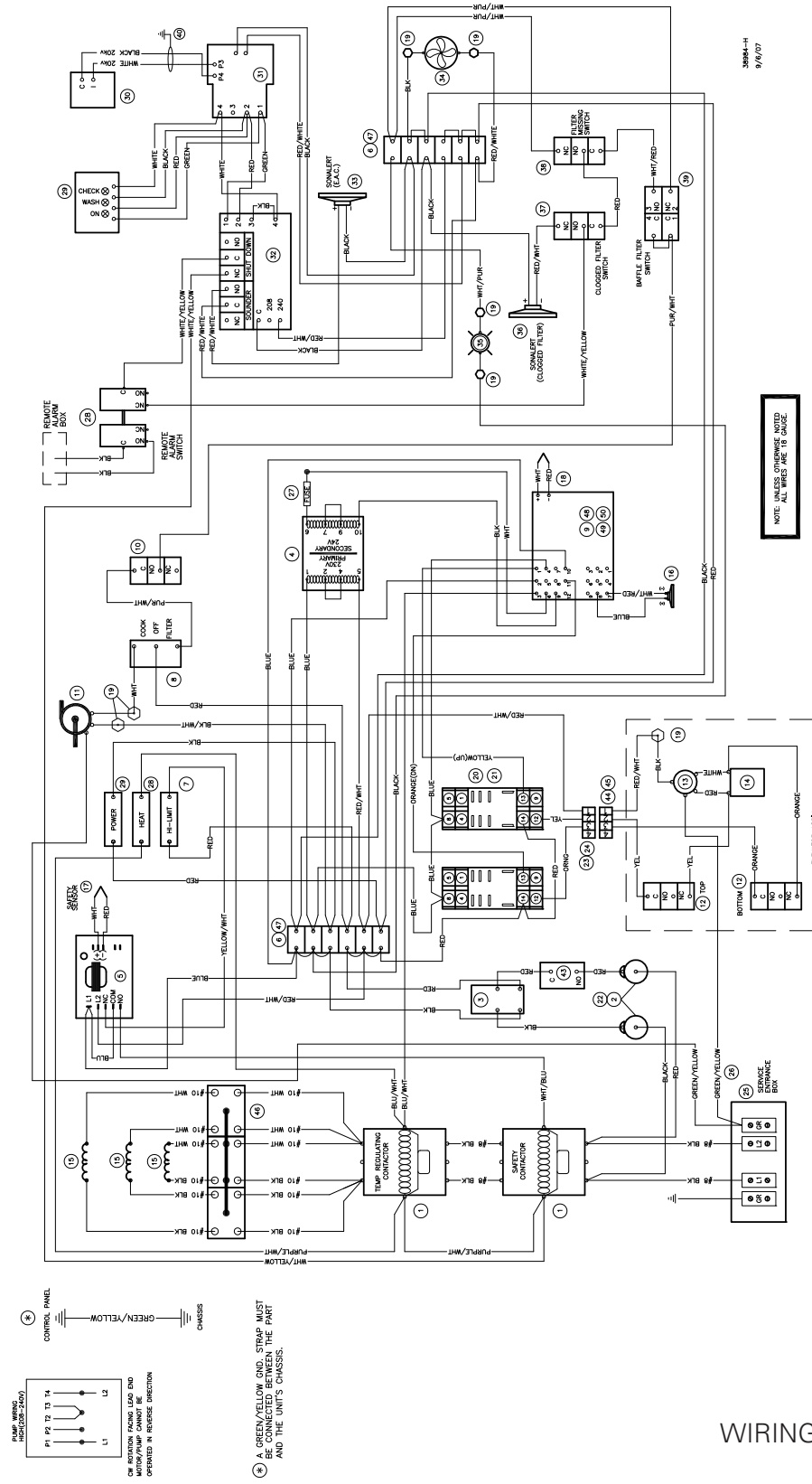

Wiring Diagram

**Model: GEF-400, GEF-560, GEF-720 &
GEF-400-VH, GEF-560-VH, GEF-720-VH**

10-07. BOM for Wiring Diagram GEF-400-VH 208-240/60/1

Item	Part Number	Qty.	Description
1	32208	2	CONTACTOR, ASSY, 208/240VAC, 3PH
2	21950	2	HOLDER, FUSE, 300V, 15A, SC 0 TO 15
3	21190	1	SWITCH, ROCKER, ON-OFF, 250V, 20A, D.P.
4	20366	1	TRANSFORMER, 20VA, 115/230V, 60HZ, CL2
4	20217	1	TRANSFORMER, 25VA, A41, 115/230V, 50HZ
5	23754	1	THERMOSTAT, HILIMIT, WATLOW, 425 DEG
6	23751	2	TERMINAL BLOCK, MA106
7	20402	1	LIGHT, INDICATOR, RED
8	21189	1	SWITCH, ROCKER, ON-OFF-ON, 250V, 20A, S.P.
9	24241	1	CONTROLLER, WATLOW, ENGLISH
10	21157	1	SWITCH, LIMIT, 15A, 250V DRAIN SWITCH
11	70912	1	PUMP/MOTOR ASSY, VIKING
12	23201	2	SWITCH, SNAP ACTION, ROLLER TYPE
13	20120	1	MOTOR, 230V, ELEVATOR, CF-720, 560, 401, GEF
14	20122	1	CAPACITOR, 4mfds, 370V, CF-720, 560, 401, GEF
15	21527	3	ELEMENT, ROUND, 3333W, 208V, CF-401, GEF-400
15	21298	3	ELEMENT, ROUND, 3333W, 240V, CF-401, GEF-400
16	22976	1	AUDIOLARM, BELL TIMER, CONTINUOUS, 2-12DC
17	23908	1	THERMOCOUPLE, SAFETY, TYPE J, SINGLE
18	23909	1	THERMOCOUPLE, VARIABLE, TYPE J, SINGLE
19	25275	7	WIRENUT, BLUE
20	20312	2	BASE, RELAY, PLUG-IN, DIN MOUNT
21	20318	2	RELAY, 240 VAC, 10A, ELECTRO-MECH
22	21900	2	FUSE, 15-AMP, SC-15
23	20007	1	CONNECTOR, 4-PIN, IN-LINE RECEPTACLE
24	21291	3	CONNECTOR, PIN, FEMALE
25	20304	2	TERMINAL BLOCK, GROUND, 4-12 GA WIRE
26	20303	3	TERMINAL BLOCK, 4-12 GA WIRE
27	38365	1	ASSY, FUSE, CONTROLLER TRANSFORMER
28	20002	1	SWITCH, ANSUL, SHUTDOWN/ALARM, 15A, 120V
29	24209	1	LED, AIR FILTER, EAC
30	21125	1	BOARD, CONTACT, EAC, VH UNITS
31	24208	1	POWER SUPPLY, EAC, W/DRIVER, 208-240V
32	23776	1	MODULE, AIR FILTER, ALARM & SHUTDOWN
33	22950	1	SONALERT, 250V, INTERMITTENT
34	33589	1	BLOWER, ASSY, VH-FRYERS
35	22300	1	LIGHT, PILOT, 250V, ROUND, RED
36	23782	1	SONALERT, 250V, CONTINUOUS BEEP
37	20390	1	SWITCH, VACUUM, ADJUSTABLE
38	24237	1	SWITCH, PLUNGER, 250V, 15A
39	32114	1	BAFFLE FILTER SWITCH, ASSY
40	20298	1	BRAID, COPPER SHIELDING
41	20399	1	LIGHT, INDICATOR, ORANGE, 250V
42	20398	1	LIGHT, INDICATOR, GREEN, 250V
43	23200	1	SWITCH, SNAP ACTION, ROLLER TYPE
44	20008	1	CONNECTOR, 4-PIN, IN-LINE PLUG
45	21290	3	CONNECTOR, PIN, MALE
46	20513	3	BREAKER, CIRCUIT, 277V, 50A, 6 PL, SER TRIP
47	21196	7	TERMINAL, BLOCK, JUMPER
48	21288	1	CONNECTOR, 9 PIN
49	21289	1	CONNECTOR, 12 PIN
50	21290	10	CONNECTOR, PIN, MALE

10-08. Wiring Diagram GEF-400-VH 208-240/60/3 or 220/50/3 Computer

WIRING DIAGRAM GEF-400-VH 208-240/60/3 AND 220/50/3 DIGITAL TIMER/TEMP CONTROL (COMPUTER)

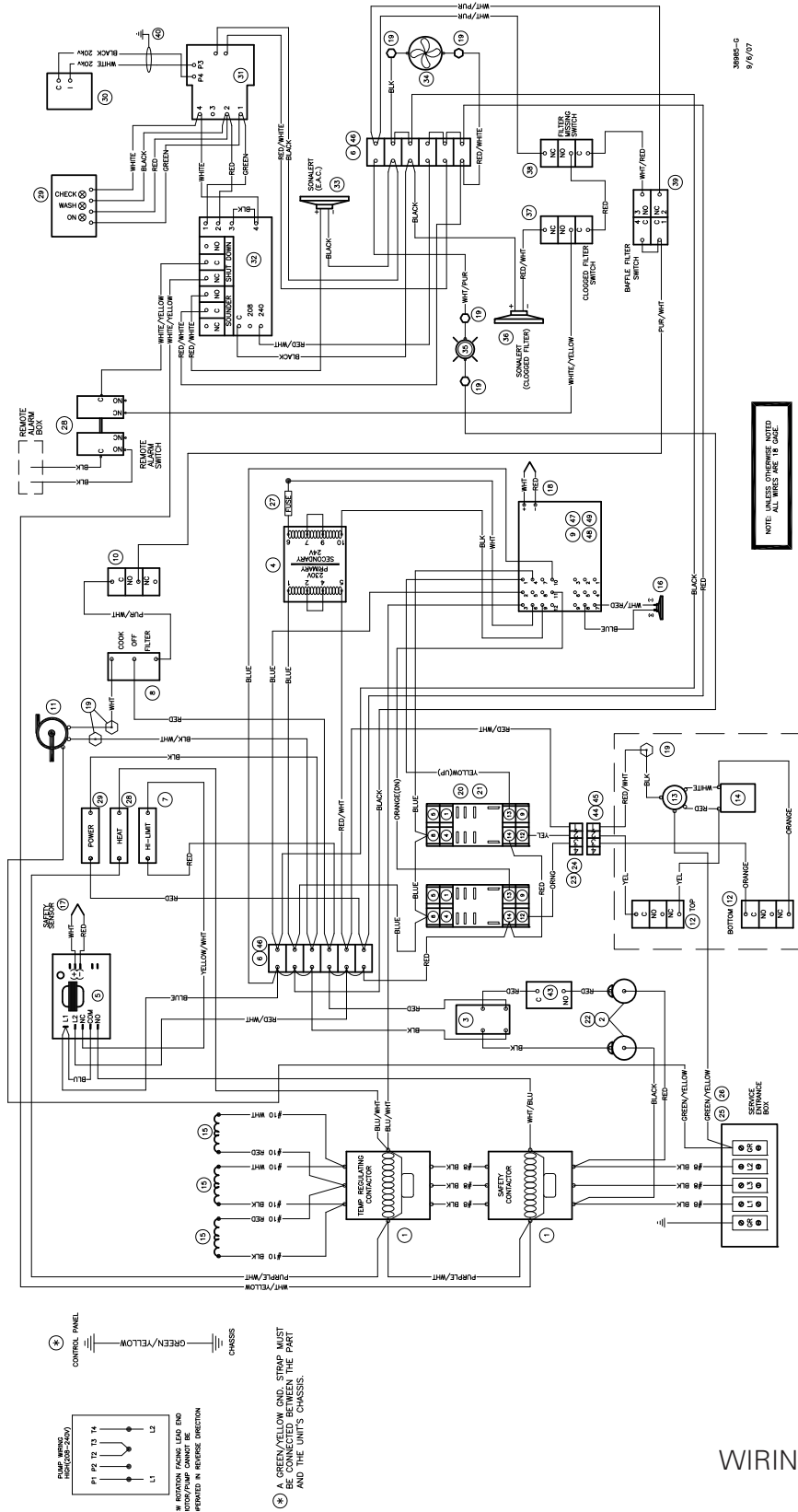

Wiring Diagram

Model: GEF-400, GEF-560, GEF-720 &
GEF-400-VH, GEF-560-VH, GEF-720-VH

10-08. BOM for Wiring Diagram GEF-400-VH 208-240/60/3 or 220/50/3

Item	Part Number	Qty.	Description
1	32208	2	CONTACTOR, ASSY, 208/240VAC, 3PH
2	21950	2	HOLDER, FUSE, 300V, 15A, SC 0 TO 15
3	21190	1	SWITCH, ROCKER, ON-OFF, 250V, 20A, D.P.
4	20366	1	TRANSFORMER, 20VA, 115/230V, 60HZ, CL2
4	20217	1	TRANSFORMER,25VA,A41,115/230V,50HZ
5	23754	1	THERMOSTAT,HILIMIT,WATLOW,425DEG
6	23751	2	TERMINAL BLOCK, MA106
7	20402	1	LIGHT, INDICATOR, RED
8	21189	1	SWITCH, ROCKER, ON-OFF-ON, 250V,20A,S.P.
9	24241	1	CONTROLLER, WATLOW, ENGLISH
10	21157	1	SWITCH, LIMIT, 15A, 250V DRAIN SWITCH
11	70912	1	PUMP/MOTOR ASSY, VIKING
12	23201	2	SWITCH, SNAP ACTION, ROLLER TYPE
13	20120	1	MOTOR, 230V, ELEVATOR,CF-720,560,401,GEF
14	20122	1	CAPACITOR, 4mfds,370V,CF-720,560,401,GEF
15	21298	3	ELEMENT, ROUND,3333W,240V,CF-401,GEF-400
15	21527	3	ELEMENT, ROUND,3333W,208V,CF-401,GEF-400
16	22976	1	AUDIOLARM, BELL TIMER, CONTINUOUS,2-12DC
17	23908	1	THERMOCOUPLE, SAFETY, TYPE J, SINGLE
18	23909	1	THERMOCOUPLE, VARIABLE, TYPE J, SINGLE
19	25275	7	WIRENUT, BLUE
20	20312	2	BASE, RELAY, PLUG-IN, DIN MOUNT
21	20318	2	RELAY, 240 VAC, 10A, ELECTRO-MECH
22	21900	2	FUSE, 15-AMP, SC-15
23	20007	1	CONNECTOR, 4-PIN, IN-LINE RECEPTACLE
24	21291	3	CONNECTOR, PIN, FEMALE
25	20304	2	TERMINAL BLOCK, GROUND, 4-12 GA WIRE
26	20303	3	TERMINAL BLOCK, 4-12 GA WIRE
27	38365	1	ASSY, FUSE, CONTROLLER TRANSFORMER
28	20002	1	SWITCH, ANSUL, SHUTDOWN/ALARM, 15A, 120V
29	24209	1	LED, AIR FILTER, EAC
30	21125	1	BOARD, CONTACT, EAC, VH UNITS
31	24208	1	POWER SUPPLY, EAC, W/DRIVER, 208-240V
32	23776	1	MODULE, AIR FILTER, ALARM & SHUTDOWN
33	22950	1	SONALERT, 250V, INTERMITTENT
34	33589	1	BLOWER, ASSY, VH-FRYERS
35	22300	1	LIGHT, PILOT, 250V, ROUND, RED
36	23782	1	SONALERT, 250V, CONTINUOUS BEEP
37	20390	1	SWITCH, VACUUM, ADJUSTABLE
38	24237	1	SWITCH, PLUNGER, 250V, 15A
39	32114	1	BAFFLE FILTER SWITCH, ASSY
40	20298	1	BRAID, COPPER SHIELDING
41	20399	1	LIGHT, INDICATOR, ORANGE
42	20398	1	LIGHT, INDICATOR, GREEN
43	23200	1	SWITCH, SNAP ACTION, ROLLER TYPE
44	20008	1	CONNECTOR, 4-PIN, IN-LINE PLUG
45	21290	3	CONNECTOR, PIN, MALE
46	21196	7	TERMINAL, BLOCK, JUMPER
47	21288	1	CONNECTOR, 9 PIN, AMP
48	21289	1	CONNECTOR, 12 PIN, AMP
49	21290	10	CONNECTOR, PIN, MALE

10-09. Wiring Diagram GEF-400-VH W/ UV 208-240/60/1 Computer

WIRING DIAGRAM GEF-400-VH 208-240/60/1
COMPUTER CONTROL/UV LIGHT

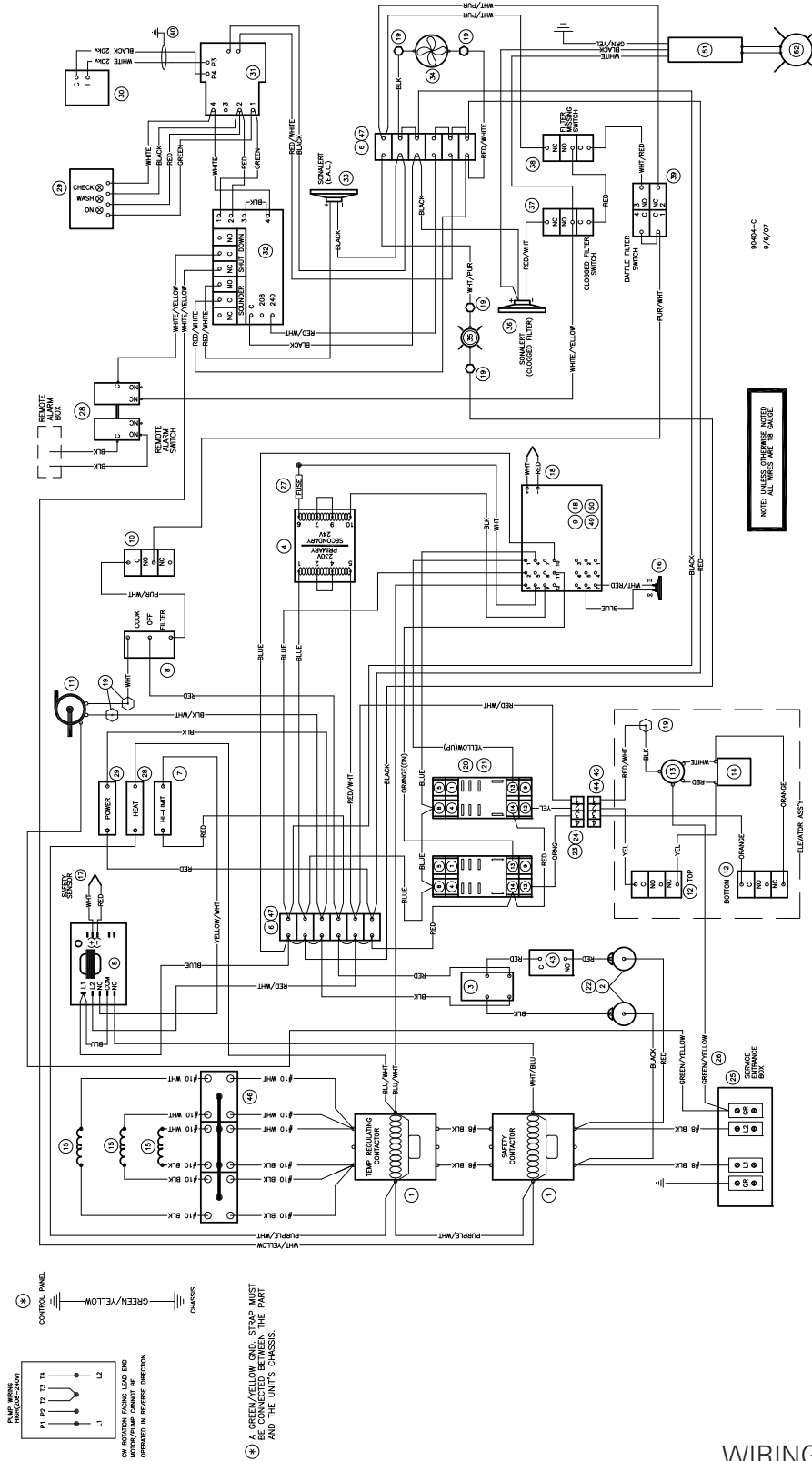

Wiring Diagram

Model: GEF-400, GEF-560, GEF-720 &
GEF-400-VH, GEF-560-VH, GEF-720-VH

10-09. BOM for Wiring Diagram GEF-400-VH W/ UV 208-240/60/1

Item	Part Number	Qty.	Description
1	32208	2	CONTACTOR, ASSY, 208/240VAC, 3PH
2	21950	2	HOLDER, FUSE, 300V, 15A, SC 0 TO 15
3	21190	1	SWITCH, ROCKER, ON-OFF, 250V, 20A, D.P.
4	20366	1	TRANSFORMER, 20VA, 115/230V, 60HZ, CL2
4	20217	1	TRANSFORMER, 25VA, A41, 115/230V, 50HZ
5	23754	1	THERMOSTAT, HI LIMIT, WATLOW, 425 DEG
6	23751	2	TERMINAL BLOCK, MA106
7	20402	1	LIGHT, INDICATOR, RED
8	21189	1	SWITCH, ROCKER, ON-OFF-ON, 250V, 20A, S.P.
9	24241	1	CONTROLLER, WATLOW, ENGLISH
10	21157	1	SWITCH, LIMIT, 15A, 250V DRAIN SWITCH
11	70912	1	PUMP/MOTOR ASSY, VIKING
12	23201	2	SWITCH, SNAP ACTION, ROLLER TYPE
13	20120	1	MOTOR, 230V, ELEVATOR, CF-720, 560, 401, GEF
14	20122	1	CAPACITOR, 4mfds, 370V, CF-720, 560, 401, GEF
15	21298	3	ELEMENT, ROUND, 3333W, 240V, CF-401, GEF-400
15	21527	3	ELEMENT, ROUND, 3333W, 208V, CF-401, GEF-400
16	22976	1	AUDIOLARM, BELL TIMER, CONTINUOUS, 2-12DC
17	23908	1	THERMOCOUPLE, SAFETY, TYPE J, SINGLE
18	23909	1	THERMOCOUPLE, VARIABLE, TYPE J, SINGLE
19	25275	7	WIRENUT, BLUE
20	20312	2	BASE, RELAY, PLUG-IN, DIN MOUNT
21	20318	2	RELAY, 240 VAC, 10A, ELECTRO-MECH
22	21900	2	FUSE, 15-AMP, SC-15
23	20007	1	CONNECTOR, 4-PIN, IN-LINE RECEPTACLE
24	21291	3	CONNECTOR, PIN, FEMALE
25	20304	2	TERMINAL BLOCK, GROUND, 4-12 GA WIRE
26	20303	3	TERMINAL BLOCK, 4-12 GA WIRE
27	38365	1	ASSY, FUSE, CONTROLLER TRANSFORMER
28	20002	1	SWITCH, ANSUL, SHUTDOWN/ALARM, 15A, 120V
29	24209	1	LED, AIR FILTER, EAC
30	21125	1	BOARD, CONTACT, EAC, VH UNITS
31	24208	1	POWER SUPPLY, EAC, W/DRIVER, 208-240V
32	23776	1	MODULE, AIR FILTER, ALARM & SHUTDOWN
33	22950	1	SONALERT, 250V, INTERMITTENT
34	33589	1	BLOWER, ASSY, VH-FRYERS
35	22300	1	LIGHT, PILOT, 250V, ROUND, RED
36	23782	1	SONALERT, 250V, CONTINUOUS BEEP
37	20390	1	SWITCH, VACUUM, ADJUSTABLE
38	24237	1	SWITCH, PLUNGER, 250V, 15A
39	32114	1	BAFFLE FILTER SWITCH, ASSY
40	20298	1	BRAID, COPPER SHIELDING
41	20399	1	LIGHT, INDICATOR, ORANGE
42	20398	1	LIGHT, INDICATOR, GREEN
43	23200	1	SWITCH, SNAP ACTION, ROLLER TYPE
44	20008	1	CONNECTOR, 4-PIN, IN-LINE PLUG
45	21290	3	CONNECTOR, PIN, MALE
46	20513	3	BREAKER, CIRCUIT, 277V, 50A, 6 PL, SER TRIP
47	21196	7	TERMINAL, BLOCK, JUMPER
48	21288	1	CONNECTOR, 9 PIN, AMP
49	21289	1	CONNECTOR, 12 PIN, AMP
50	21290	10	CONNECTOR, PIN, MALE
51	20373	1	BALLAST/LAMP ASSY, COMPLETE
52	90226	1	LAMP, ASSY, 16-IN, UV, REPLACEMENT ONLY

10-10. Wiring Diagram GEF-400-VH W/ UV 208-240/60/3 Computer

WIRING DIAGRAM GEF-400-VH 208-240/60/3 AND 220/50/3
COMPUTER CONTROL/ UV LIGHT

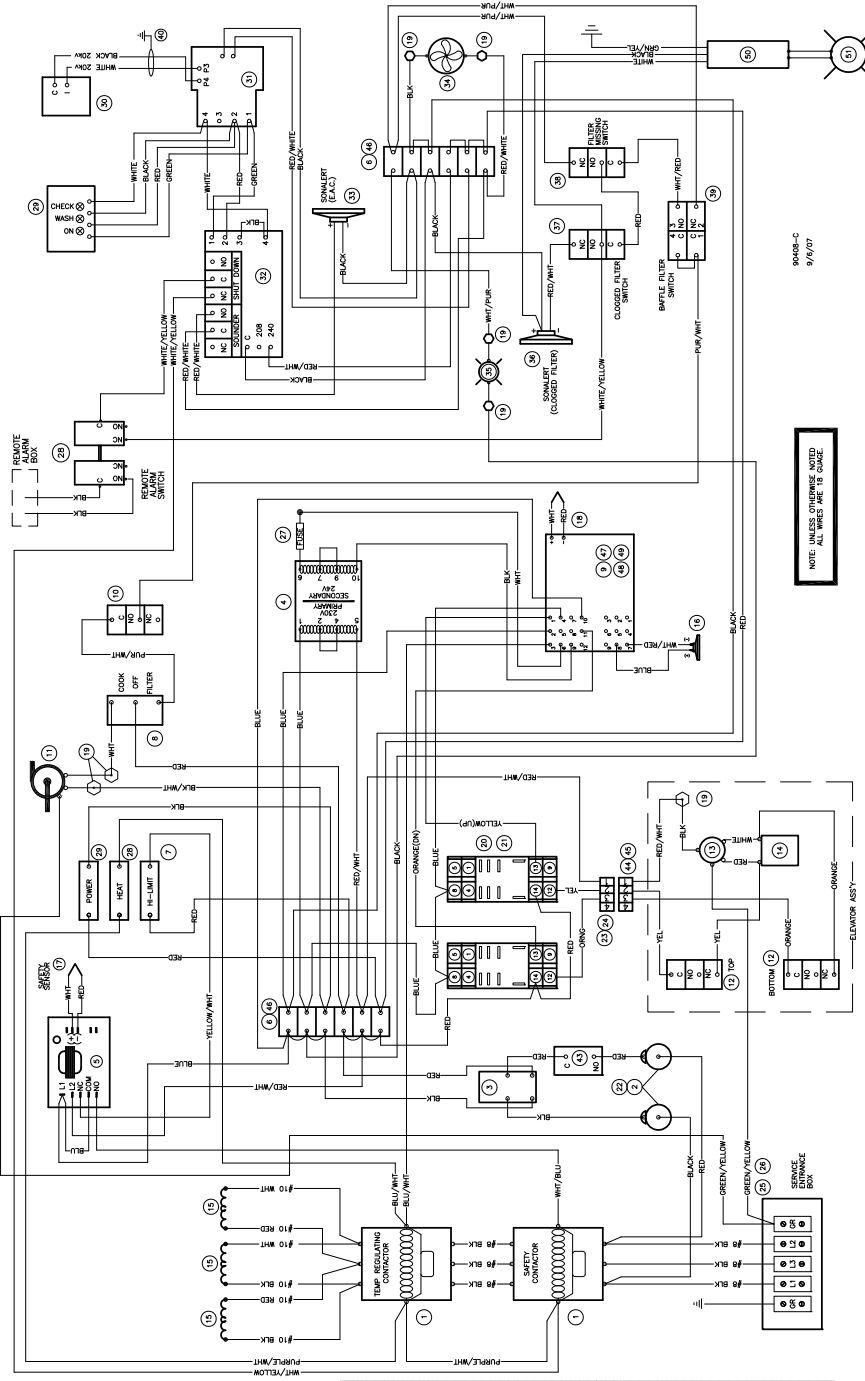

PUMP WIRING (208-240V)
P1 P2 T3 T4
L1

OR REVERSE PUMP LEAD DNO
OPERATED IN REVERSE DIRECTION

CONTROL PANEL
GREEN/YELLOW
GROUND

★ A SAFETY FUSE (5A) - TEMP. MUST
BE CONNECTED BETWEEN THE PART
AND THE UNIT'S CHASSIS.

NOTE: UNLESS OTHERWISE NOTED
ALL WIRES ARE 18 GAUGE

90408-C
9/6/07

Wiring Diagram

**Model: GEF-400, GEF-560, GEF-720 &
GEF-400-VH, GEF-560-VH, GEF-720-VH**

10-10. BOM for Wiring Diagram GEF-400-VH W/ UV 208-240/60/3

Item	Part Number	Qty.	Description
1	32208	2	CONTACTOR, ASSY, 208/240VAC, 3PH
2	21950	2	HOLDER, FUSE, 300V, 15A, SC 0 TO 15
3	21190	1	SWITCH, ROCKER, ON-OFF, 250V, 20A, D.P.
4	20366	1	TRANSFORMER, 20VA, 115/230V, 60HZ, CL2
4	20217	1	TRANSFORMER, 25VA, A41, 115/230V, 50HZ
5	23754	1	THERMOSTAT, HI LIMIT, WATLOW, 425 DEG
6	23751	2	TERMINAL BLOCK, MA106
7	20402	1	LIGHT, INDICATOR, RED
8	21189	1	SWITCH, ROCKER, ON-OFF-ON, 250V, 20A, S.P.
9	24241	1	CONTROLLER, WATLOW, ENGLISH
10	21157	1	SWITCH, LIMIT, 15A, 250V DRAIN SWITCH
11	70912	1	PUMP/MOTOR ASSY, VIKING
12	23201	2	SWITCH, SNAP ACTION, ROLLER TYPE
13	20120	1	MOTOR, 230V, ELEVATOR, CF-720, 560, 401, GEF
14	20122	1	CAPACITOR, 4mfds, 370V, CF-720, 560, 401, GEF
15	21298	3	ELEMENT, ROUND, 3333W, 240V, CF-401, GEF-400
15	21527	3	ELEMENT, ROUND, 3333W, 208V, CF-401, GEF-400
16	22976	1	AUDIOLARM, BELL TIMER, CONTINUOUS, 2-12DC
17	23908	1	THERMOCOUPLE, SAFETY, TYPE J, SINGLE
18	23909	1	THERMOCOUPLE, VARIABLE, TYPE J, SINGLE
19	25275	7	WIRENUT, BLUE
20	20312	2	BASE, RELAY, PLUG-IN, DIN MOUNT
21	20318	2	RELAY, 240 VAC, 10A, ELECTRO-MECH
22	21900	2	FUSE, 15-AMP, SC-15
23	20007	1	CONNECTOR, 4-PIN, IN-LINE RECEPTACLE
24	21291	3	CONNECTOR, PIN, FEMALE
25	20304	2	TERMINAL BLOCK, GROUND, 4-12 GA WIRE
26	20303	3	TERMINAL BLOCK, 4-12 GA WIRE
27	38365	1	ASSY, FUSE, CONTROLLER TRANSFORMER
28	20002	1	SWITCH, ANSUL, SHUTDOWN/ALARM, 15A, 120V
29	24209	1	LED, AIR FILTER, EAC
30	21125	1	BOARD, CONTACT, EAC, VH UNITS
31	24208	1	POWER SUPPLY, EAC, W/DRIVER, 208-240V
32	23776	1	MODULE, AIR FILTER, ALARM & SHUTDOWN
33	22950	1	SONALERT, 250V, INTERMITTENT
34	33589	1	BLOWER, ASSY, VH-FRYERS
35	22300	1	LIGHT, PILOT, 250V, ROUND, RED
36	23782	1	SONALERT, 250V, CONTINUOUS BEEP
37	20390	1	SWITCH, VACUUM, ADJUSTABLE
38	24237	1	SWITCH, PLUNGER, 250V, 15A
39	32114	1	BAFFLE FILTER SWITCH, ASSY
40	20298	1	BRAID, COPPER SHIELDING
41	20399	1	LIGHT, INDICATOR, ORANGE
42	20398	1	LIGHT, INDICATOR, GREEN
43	23200	1	SWITCH, SNAP ACTION, ROLLER TYPE
44	20008	1	CONNECTOR, 4-PIN, IN-LINE PLUG
45	21290	3	CONNECTOR, PIN, MALE
46	21196	7	TERMINAL, BLOCK, JUMPER
47	21288	1	CONNECTOR, 9 PIN, AMP
48	21289	1	CONNECTOR, 12 PIN, AMP
49	21290	10	CONNECTOR, PIN, MALE
50	20373	1	BALLAST/LAMP ASSY, COMPLETE
51	90226	1	LAMP, ASSY, 16-IN, UV, REPLACEMENT ONLY

10-11. Wiring Diagram GEF-560-VH 208-240/60/1 Computer

WIRING DIAGRAM GEF-560-VH 208-240/60/1 DIGITAL TIMER/TEMP CONTROL (COMPUTER)

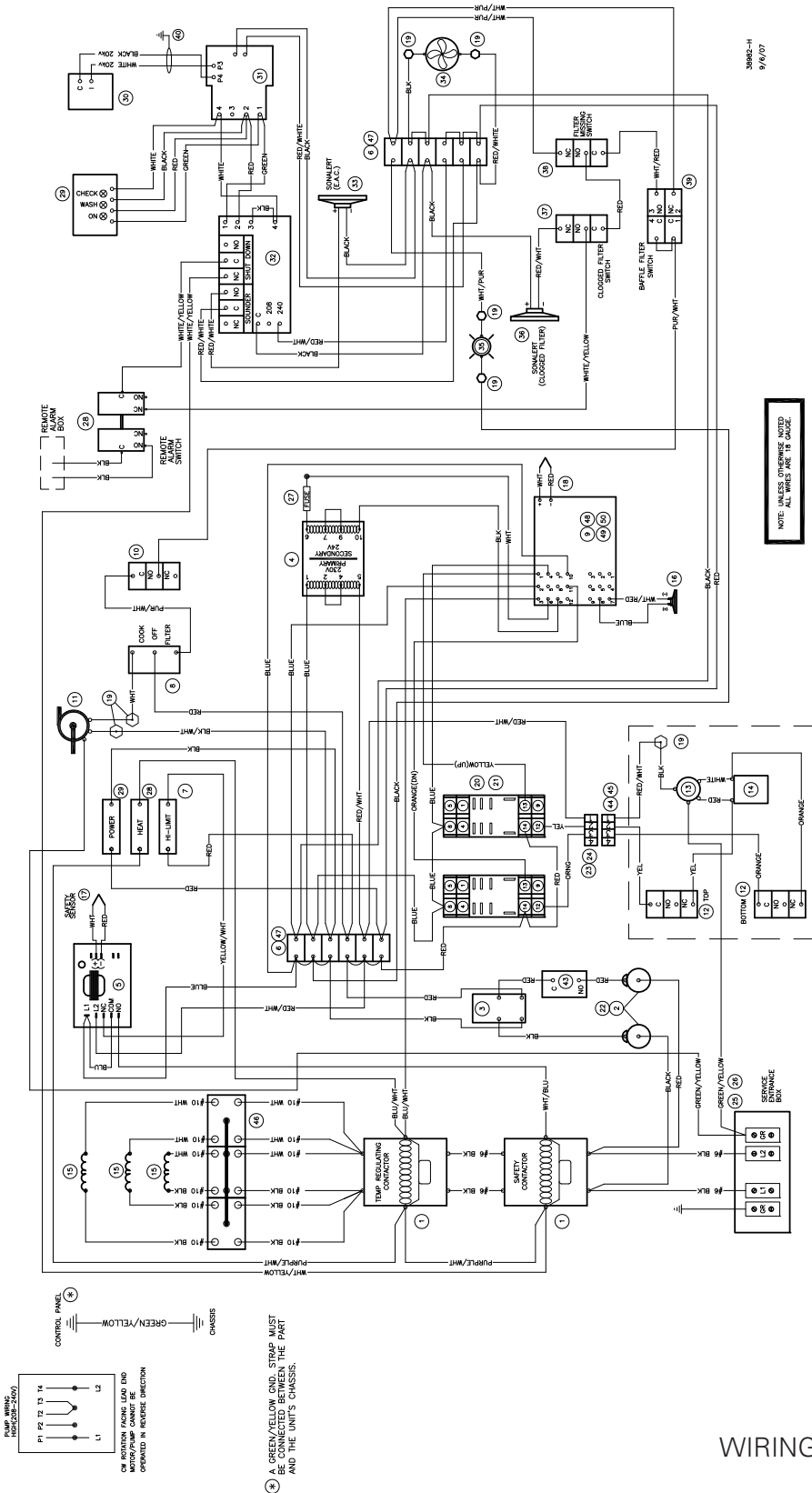

Wiring Diagram

Model: GEF-400, GEF-560, GEF-720 &
GEF-400-VH, GEF-560-VH, GEF-720-VH

10-11. BOM for Wiring Diagram GEF-560-VH 208-240/60/1

Item	Part Number	Qty.	Description
1	32193	2	CONTACTOR, ASSY, 1 PH, 75A, 208/240V
2	21950	2	HOLDER, FUSE, 300V, 15A, SC 0 TO 15
3	21190	1	SWITCH, ROCKER, ON-OFF, 250V, 20A, D.P.
4	20366	1	TRANSFORMER, 20VA, 115/230V, 60HZ, CL2
4	20217	1	TRANSFORMER, 25VA, A41, 115/230V, 50HZ
5	23754	1	THERMOSTAT, HILIMIT, WATLOW, 425 DEG
6	23751	2	TERMINAL BLOCK, MA106
7	20402	1	LIGHT, INDICATOR, RED
8	21189	1	SWITCH, ROCKER, ON-OFF-ON, 250V, 20A, S.P.
9	24241	1	CONTROLLER, WATLOW, ENGLISH
10	21157	1	SWITCH, LIMIT, 15A, 250V DRAIN SWITCH
11	70912	1	PUMP/MOTOR ASSY, VIKING
12	23201	2	SWITCH, SNAP ACTION, ROLLER TYPE
13	20120	1	MOTOR, 230V, ELEVATOR, GEF
14	20122	1	CAPACITOR, 4mfd, 370V, GEF
15	21299	3	ELEMENT, ROUND, 5000W, 240V, GEF 560
15	21526	3	ELEMENT, ROUND, 5000W, 208V, GEF 560
16	22976	1	AUDIOLARM, BELL TIMER, CONTINUOUS, 2-12DC
17	23908	1	THERMOCOUPLE, SAFETY, TYPE J, SINGLE
18	23909	1	THERMOCOUPLE, VARIABLE, TYPE J, SINGLE
19	25275	7	WIRENUT, BLUE
20	20312	2	BASE, RELAY, PLUG-IN, DIN MOUNT
21	20318	2	RELAY, 240 VAC, 10A, ELECTRO-MECH
22	21900	2	FUSE, 15-AMP, SC-15
23	20007	1	CONNECTOR, 4-PIN, IN-LINE RECEPTACLE
24	21291	3	CONNECTOR, PIN, FEMALE
25	20304	2	TERMINAL BLOCK, GROUND, 4-12 GA WIRE
26	20303	3	TERMINAL BLOCK, 4-12 GA WIRE
27	38365	1	ASSY, FUSE, CONTROLLER TRANSFORMER
28	20002	1	SWITCH, ANSUL, SHUTDOWN/ALARM, 15A, 120V
29	24209	1	LED, AIR FILTER, EAC
30	21125	1	BOARD, CONTACT, EAC, VH UNITS
31	24208	1	POWER SUPPLY, EAC, W/DRIVER, 208-240V
32	23776	1	MODULE, AIR FILTER, ALARM & SHUTDOWN
33	22950	1	SONALERT, 250V, INTERMITTENT
34	33589	1	BLOWER, ASSY, VH-FRYERS
35	22300	1	LIGHT, PILOT, 250V, ROUND, RED
36	23782	1	SONALERT, 250V, CONTINUOUS BEEP
37	20390	1	SWITCH, VACUUM, ADJUSTABLE
38	24237	1	SWITCH, PLUNGER, 250V, 15A
39	32114	1	BAFFLE FILTER SWITCH, ASSY
40	20298	1	BRAID, COPPER SHIELDING, 15' ROLL
41	20399	1	LIGHT, INDICATOR, ORANGE
42	20398	1	LIGHT, INDICATOR, GREEN
43	23200	1	SWITCH, SNAP ACTION, ROLLER TYPE
44	20008	1	CONNECTOR, 4-PIN, IN-LINE PLUG
45	21290	1	CONNECTOR, PIN, MALE
46	20513	3	BREAKER, CIRCUIT, 277V, 50A, 6 PL, SER TRIP
47	21196	1	TERMINAL, BLOCK, JUMPER
48	21288	7	CONNECTOR, 9 PIN, AMP
49	21289	1	CONNECTOR, 12 PIN, AMP
50	21290	1	CONNECTOR, PIN, MALE

Wiring Diagram

Model: GEF-400, GEF-560, GEF-720 &
GEF-400-VH, GEF-560-VH, GEF-720-VH

10-12. BOM for Wiring Diagram GEF-560-VH 208-240/60/3 or 220/60/3

Item	Part Number	Qty.	Description
1	32208	2	CONTACTOR, ASSY, 1 PH, 75A, 208/240V
2	21950	2	HOLDER, FUSE, 300V, 15A, SC 0 TO 15
3	21190	1	SWITCH, ROCKER, ON-OFF, 250V, 20A, D.P.
4	20366	1	TRANSFORMER, 20VA, 115/230V, 60HZ, CL2
4	20217	1	TRANSFORMER, 25VA, A41, 115/230V, 50HZ
5	23754	1	THERMOSTAT, HILIMIT, WATLOW, 425DEG
6	23751	2	TERMINAL BLOCK, MA106
7	20402	1	LIGHT, INDICATOR, RED
8	21189	1	SWITCH, ROCKER, ON-OFF-ON, 250V, 20A, S.P.
9	24241	1	CONTROLLER, WATLOW, ENGLISH
10	21157	1	SWITCH, LIMIT, 15A, 250V DRAIN SWITCH
11	70912	1	PUMP/MOTOR ASSY, VIKING
12	23201	2	SWITCH, SNAP ACTION, ROLLER TYPE
13	20120	1	MOTOR, 230V, ELEVATOR, GEF
14	20122	1	CAPACITOR, 4mfd, 370V, GEF
15	21299	3	ELEMENT, ROUND, 5000W, 240V, GEF 560
15	21526	3	ELEMENT, ROUND, 5000W, 208V, GEF 560
16	22976	1	AUDIOLARM, BELL TIMER, CONTINUOUS, 2-12DC
17	23908	1	THERMOCOUPLE, SAFETY, TYPE J, SINGLE
18	23909	1	THERMOCOUPLE, VARIABLE, TYPE J, SINGLE
19	25275	7	WIRENUT, BLUE
20	20312	2	BASE, RELAY, PLUG-IN, DIN MOUNT
21	20318	2	RELAY, 240 VAC, 10A, ELECTRO-MECH
22	21900	2	FUSE, 15-AMP, SC-15
23	20007	1	CONNECTOR, 4-PIN, IN-LINE RECEPTACLE
24	21291	3	CONNECTOR, PIN, FEMALE
25	20304	2	TERMINAL BLOCK, GROUND, 4-12 GA WIRE
26	20303	3	TERMINAL BLOCK, 4-12 GA WIRE
27	38365	1	ASSY, FUSE, CONTROLLER TRANSFORMER
28	20002	1	SWITCH, ANSUL, SHUTDOWN/ALARM, 15A, 120V
29	24209	1	LED, AIR FILTER, EAC
30	21125	1	BOARD, CONTACT, EAC, VH UNITS
31	24208	1	POWER SUPPLY, EAC, W/DRIVER, 208-240V
32	23776	1	MODULE, AIR FILTER, ALARM & SHUTDOWN
33	22950	1	SONALERT, 250V, INTERMITTENT
34	33589	1	BLOWER, ASSY, VH-FRYERS
35	22300	1	LIGHT, PILOT, 250V, ROUND, RED
36	23782	1	SONALERT, 250V, CONTINOUS BEEP
37	20390	1	SWITCH, VACUUM, ADJUSTABLE
38	24237	1	SWITCH, PLUNGER, 250V, 15A
39	32114	1	BAFFLE FILTER SWITCH, ASSY
40	20298	1	BRAID, COPPER SHIELDING, 15' ROLL
41	20399	1	LIGHT, INDICATOR, ORANGE
42	20398	1	LIGHT, INDICATOR, GREEN
43	23200	1	SWITCH, SNAP ACTION, ROLLER TYPE
44	20008	1	CONNECTOR, 4-PIN, IN-LINE PLUG
45	21290	1	CONNECTOR, PIN, MALE
46	21196	1	TERMINAL, BLOCK, JUMPER
47	21288	7	CONNECTOR, 9 PIN, AMP
48	21289	1	CONNECTOR, 12 PIN, AMP
49	21290	1	CONNECTOR, PIN, MALE

Wiring Diagram

**Model: GEF-400, GEF-560, GEF-720 &
GEF-400-VH, GEF-560-VH, GEF-720-VH**

10-13. BOM for Wiring Diagram GEF-560-VH 208-240/60/1 W/ UV

Item	Part Number	Qty.	Description
1	32208	2	CONTACTOR, ASSY, 1 PH, 75A, 208/240V
2	21950	2	HOLDER, FUSE, 300V, 15A, SC 0 TO 15
3	21190	1	SWITCH, ROCKER, ON-OFF, 250V, 20A, D.P.
4	20366	1	TRANSFORMER, 20VA, 115/230V, 60HZ, CL2
4	20217	1	TRANSFORMER,25VA,A41,115/230V,50HZ
5	23754	1	THERMOSTAT,HILIMIT,WATLOW,425DEG
6	23751	2	TERMINAL BLOCK, MA106
7	20402	1	LIGHT, INDICATOR, RED
8	21189	1	SWITCH, ROCKER, ON-OFF-ON, 250V,20A,S.P.
9	24241	1	CONTROLLER, WATLOW, ENGLISH
10	21157	1	SWITCH, LIMIT, 15A, 250V DRAIN SWITCH
11	70912	1	PUMP/MOTOR ASSY, VIKING
12	23201	2	SWITCH, SNAP ACTION, ROLLER TYPE
13	20120	1	MOTOR, 230V, ELEVATOR,GEF
14	20122	1	CAPACITOR, 4mfds,370V,GEF
15	21299	3	ELEMENT, ROUND, 5000W, 240V, GEF 560
15	21526	3	ELEMENT, ROUND, 5000W, 208V, GEF 560
16	22976	1	AUDIOLARM, BELL TIMER, CONTINUOUS,2-12DC
17	23908	1	THERMOCOUPLE, SAFETY, TYPE J, SINGLE
18	23909	1	THERMOCOUPLE, VARIABLE, TYPE J, SINGLE
19	25275	7	WIRENUT, BLUE
20	20312	2	BASE, RELAY, PLUG-IN, DIN MOUNT
21	20318	2	RELAY, 240 VAC, 10A, ELECTRO-MECH
22	21900	2	FUSE, 15-AMP, SC-15
23	20007	1	CONNECTOR, 4-PIN, IN-LINE RECEPTACLE
24	21291	3	CONNECTOR, PIN, FEMALE
25	20304	2	TERMINAL BLOCK, GROUND, 4-12 GA WIRE
26	20303	3	TERMINAL BLOCK, 4-12 GA WIRE
27	38365	1	ASSY, FUSE, CONTROLLER TRANSFORMER
28	20002	1	SWITCH, ANSUL, SHUTDOWN/ALARM, 15A, 120V
29	24209	1	LED, AIR FILTER, EAC
30	21125	1	BOARD, CONTACT, EAC, VH UNITS
31	24208	1	POWER SUPPLY, EAC, W/DRIVER, 208-240V
32	23776	1	MODULE, AIR FILTER, ALARM & SHUTDOWN
33	22950	1	SONALERT, 250V, INTERMITTENT
34	33589	1	BLOWER, ASSY, VH-FRYERS
35	22300	1	LIGHT, PILOT, 250V, ROUND, RED
36	23782	1	SONALERT, 250V, CONTINUOUS BEEP
37	20390	1	SWITCH, VACUUM, ADJUSTABLE
38	24237	1	SWITCH, PLUNGER, 250V, 15A
39	32114	1	BAFFLE FILTER SWITCH, ASSY
40	20298	1	BRAID, COPPER SHIELDING, 15' ROLL
41	20399	1	LIGHT, INDICATOR, ORANGE
42	20398	1	LIGHT, INDICATOR, GREEN
43	23200	1	SWITCH, SNAP ACTION, ROLLER TYPE
44	20008	1	CONNECTOR, 4-PIN, IN-LINE PLUG
45	21290	1	CONNECTOR, PIN, MALE
46	20513	3	BREAKER, CIRCUIT,277V,50A,6 PL, SER TRIP
47	21196	1	TERMINAL, BLOCK, JUMPER
48	21288	7	CONNECTOR, 9 PIN, AMP
49	21289	1	CONNECTOR, 12 PIN, AMP
50	21290	1	CONNECTOR, PIN, MALE
51	20373	1	UV-LAMP, ASSY (BALLAST & LAMP)
52	90226	1	LAMP, ASSY, 16-IN, UV, REPLACEMENT ONLY

10-14. Wiring Diagram GEF-560-VH 208-240/60/3 W/ UV Computer

WIRING DIAGRAM GEF-560-VH 208-240/60/3 AND 220/50/3
 COMPUTER CONTROL W/ UV LIGHT

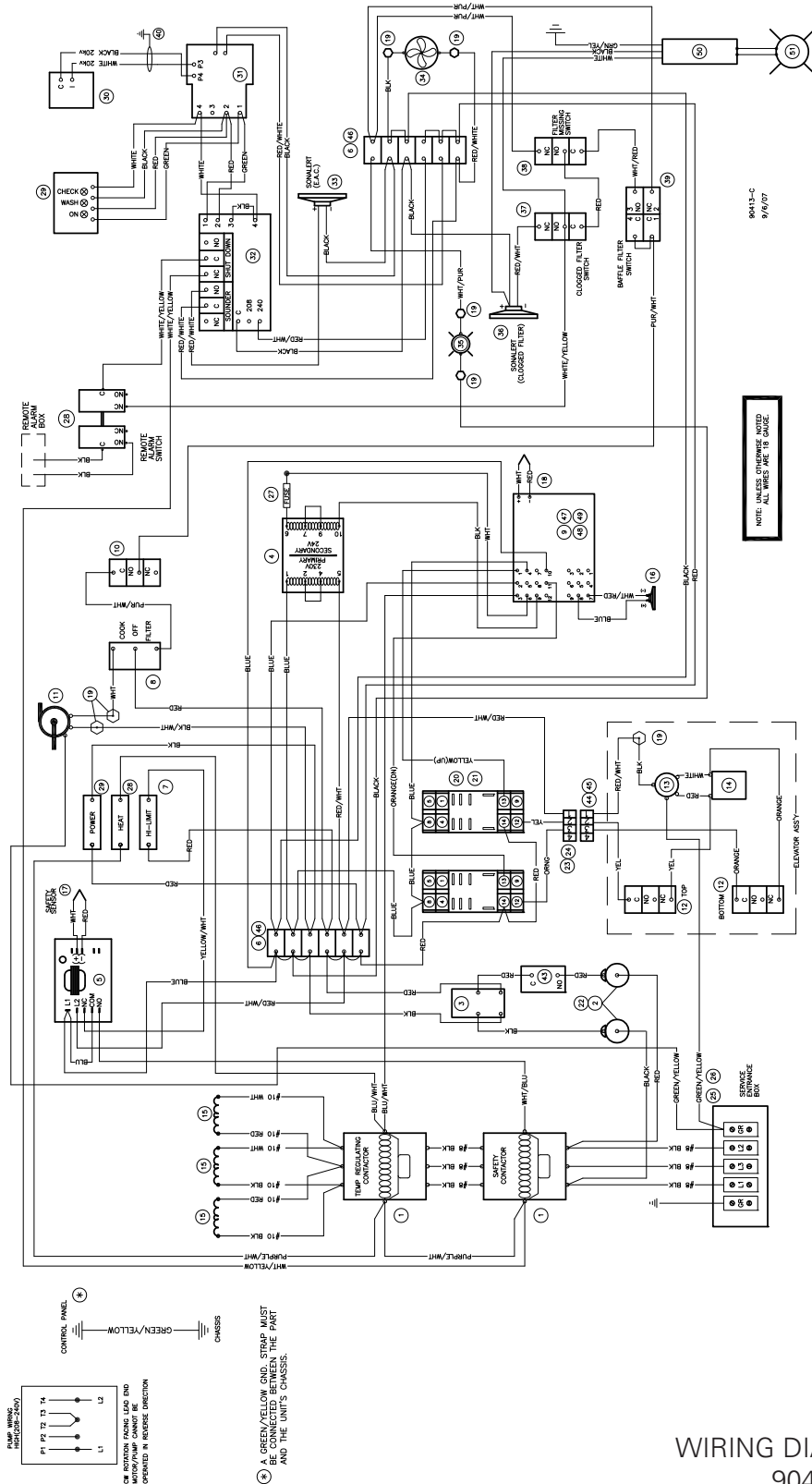

Wiring Diagram

**Model: GEF-400, GEF-560, GEF-720 &
GEF-400-VH, GEF-560-VH, GEF-720-VH**

10-14. BOM for Wiring Diagram GEF-560-VH 208-240/60/3 or 220/60/3

Item	Part Number	Qty.	Description
1	32208	2	CONTACTOR, ASSY, 1 PH, 75A, 208/240V
2	21950	2	HOLDER, FUSE, 300V, 15A, SC 0 TO 15
3	21190	1	SWITCH, ROCKER, ON-OFF, 250V, 20A, D.P.
4	20366	1	TRANSFORMER, 20VA, 115/230V, 60HZ, CL2
4	20217	1	TRANSFORMER,25VA,A41,115/230V,50HZ
5	23754	1	THERMOSTAT,HILIMIT,WATLOW,425DEG
6	23751	2	TERMINAL BLOCK, MA106
7	20402	1	LIGHT, INDICATOR, RED
8	21189	1	SWITCH, ROCKER, ON-OFF-ON, 250V,20A,S.P.
9	24241	1	CONTROLLER, WATLOW, ENGLISH
10	21157	1	SWITCH, LIMIT, 15A, 250V DRAIN SWITCH
11	70912	1	PUMP/MOTOR ASSY, VIKING
12	23201	2	SWITCH, SNAP ACTION, ROLLER TYPE
13	20120	1	MOTOR, 230V, ELEVATOR,GEF
14	20122	1	CAPACITOR, 4mfds,370V,GEF
15	21299	3	ELEMENT, ROUND, 5000W, 240V, GEF 560
15	21526	3	ELEMENT, ROUND, 5000W, 208V, GEF 560
16	22976	1	AUDIOLARM, BELL TIMER, CONTINUOUS,2-12DC
17	23908	1	THERMOCOUPLE, SAFETY, TYPE J, SINGLE
18	23909	1	THERMOCOUPLE, VARIABLE, TYPE J, SINGLE
19	25275	7	WIRENUT, BLUE
20	20312	2	BASE, RELAY, PLUG-IN, DIN MOUNT
21	20318	2	RELAY, 240 VAC, 10A, ELECTRO-MECH
22	21900	2	FUSE, 15-AMP, SC-15
23	20007	1	CONNECTOR, 4-PIN, IN-LINE RECEPTACLE
24	21291	3	CONNECTOR, PIN, FEMALE
25	20304	2	TERMINAL BLOCK, GROUND, 4-12 GA WIRE
26	20303	3	TERMINAL BLOCK, 4-12 GA WIRE
27	38365	1	ASSY, FUSE, CONTROLLER TRANSFORMER
28	20002	1	SWITCH, ANSUL, SHUTDOWN/ALARM, 15A, 120V
29	24209	1	LED, AIR FILTER, EAC
30	21125	1	BOARD, CONTACT, EAC, VH UNITS
31	24208	1	POWER SUPPLY, EAC, W/DRIVER, 208-240V
32	23776	1	MODULE, AIR FILTER, ALARM & SHUTDOWN
33	22950	1	SONALERT, 250V, INTERMITTENT
34	33589	1	BLOWER, ASSY, VH-FRYERS
35	22300	1	LIGHT, PILOT, 250V, ROUND, RED
36	23782	1	SONALERT, 250V, CONTINUOUS BEEP
37	20390	1	SWITCH, VACUUM, ADJUSTABLE
38	24237	1	SWITCH, PLUNGER, 250V, 15A
39	32114	1	BAFFLE FILTER SWITCH, ASSY
40	20298	1	BRAID, COPPER SHIELDING, 15' ROLL
41	20399	1	LIGHT, INDICATOR, ORANGE
42	20398	1	LIGHT, INDICATOR, GREEN
43	23200	1	SWITCH, SNAP ACTION, ROLLER TYPE
44	20008	1	CONNECTOR, 4-PIN, IN-LINE PLUG
45	21290	1	CONNECTOR, PIN, MALE
46	21196	1	TERMINAL, BLOCK, JUMPER
47	21288	7	CONNECTOR, 9 PIN, AMP
48	21289	1	CONNECTOR, 12 PIN, AMP
49	21290	1	CONNECTOR, PIN, MALE
50	20373	1	UV-LAMP, ASSY (BALLAST & LAMP)
51	90226	1	LAMP, ASSY, 16-IN, UV, REPLACEMENT ONLY

10-15. Wiring Diagram GEF-720-VH 208-240/60/3 or 220/50/3 Computer

WIRING DIAGRAM GEF-720-VH 208-240/60/3 AND 220/50/3 DIGITAL TIMER/TEMP CONTROL (COMPUTER)

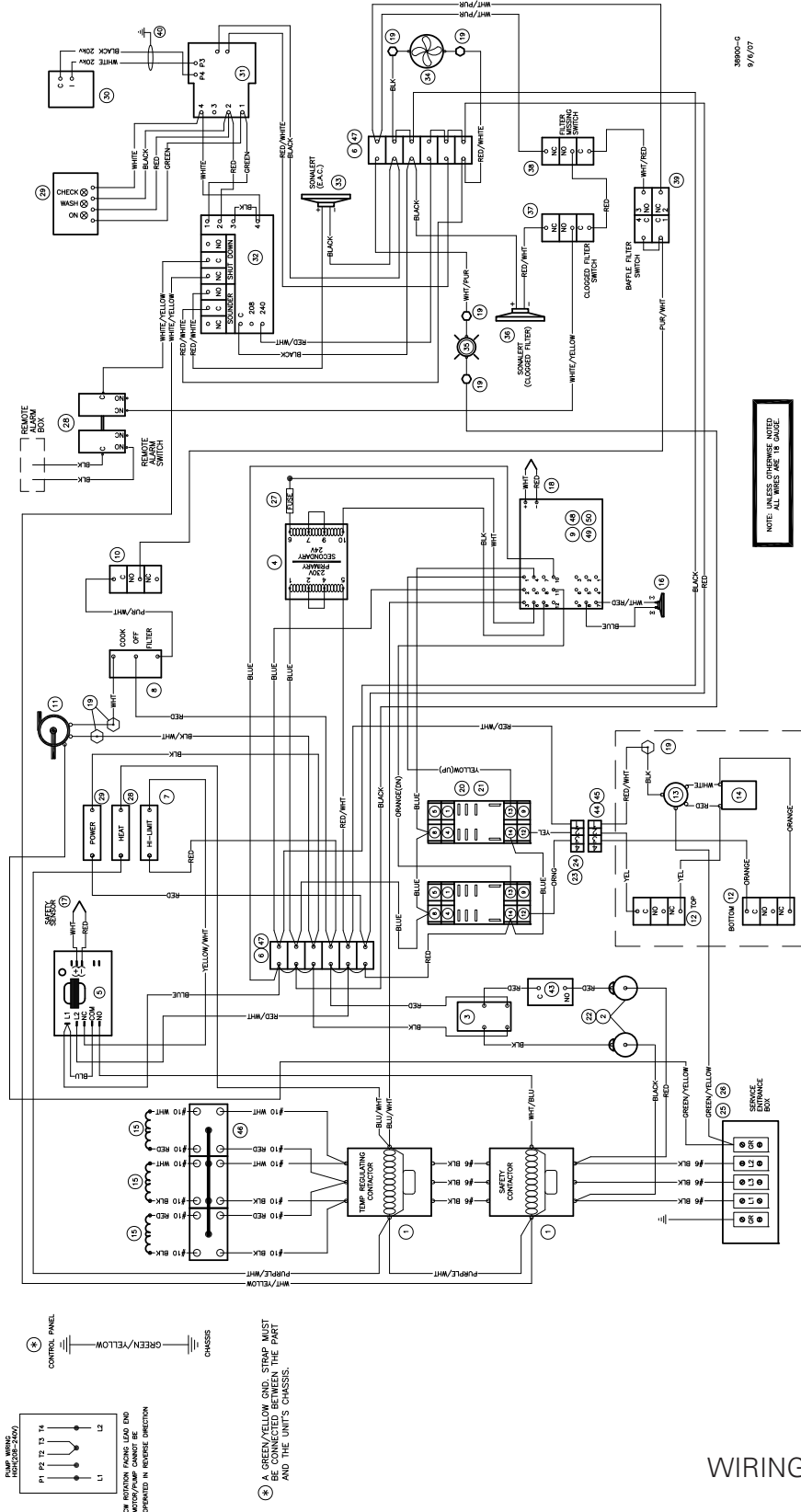

WIRING DIAGRAM P/N:
38900-G

Wiring Diagram

**Model: GEF-400, GEF-560, GEF-720 &
GEF-400-VH, GEF-560-VH, GEF-720-VH**

10-15. BOM for Wiring Diagram GEF-720-VH 208-240/60/3 or 220/50/3

Item	Part Number	Qty.	Description
1	32208	2	CONTACTOR, ASSY, 1 PH, 75A, 208/240V
2	21950	2	HOLDER, FUSE, 300V, 15A, SC 0 TO 15
3	21190	1	SWITCH, ROCKER, ON-OFF, 250V, 20A, D.P.
4	20366	1	TRANSFORMER, 20VA, 115/230V, 60HZ, CL2
4	20217	1	TRANSFORMER, 25VA, A41, 115/230V, 50HZ
5	23754	1	THERMOSTAT, LIMIT, WATLOW, 425 DEG
6	23751	2	TERMINAL BLOCK, MA106
7	20402	1	LIGHT, INDICATOR, RED
8	21189	1	SWITCH, ROCKER, ON-OFF-ON, 250V, 20A, S.P.
9	24241	1	CONTROLLER, WATLOW, ENGLISH
10	21157	1	SWITCH, LIMIT, 15A, 250V DRAIN SWITCH
11	70912	1	PUMP/MOTOR ASSY, VIKING
12	23201	2	SWITCH, SNAP ACTION, ROLLER TYPE
13	20120	1	MOTOR, 230V, ELEVATOR, GEF
14	20122	1	CAPACITOR, 4mfs, 370V, GEF
15	20309	3	ELEMENT, 6666W, 240V, GEF-720
15	20306	3	ELEMENT, 6666W, 208V, GEF-720
16	22976	1	AUDIOLARM, BELL TIMER, CONTINUOUS, 2-12DC
17	23908	1	THERMOCOUPLE, SAFETY, TYPE J, SINGLE
18	23909	1	THERMOCOUPLE, VARIABLE, TYPE J, SINGLE
19	25275	7	WIRENUT, BLUE
20	20312	2	BASE, RELAY, PLUG-IN, DIN MOUNT
21	20318	2	RELAY, 240 VAC, 10A, ELECTRO-MECH
22	21900	2	FUSE, 15-AMP, SC-15
23	20007	1	CONNECTOR, 4-PIN, IN-LINE RECEPTACLE
24	24291	3	CONNECTOR, PIN, FEMALE
25	20304	2	TERMINAL BLOCK, GROUND, 4-12 GA WIRE
26	20303	3	TERMINAL BLOCK, 4-12 GA WIRE
27	38365	1	ASSY, FUSE, CONTROLLER TRANSFORMER
28	20002	1	SWITCH, ANSUL, SHUTDOWN/ALARM, 15A, 120V
29	24209	1	LED, AIR FILTER, EAC
30	21125	1	BOARD, CONTACT, EAC, VH UNITS
31	24208	1	POWER SUPPLY, EAC, W/DRIVER, 208-240V
32	23776	1	MODULE, AIR FILTER, ALARM & SHUTDOWN
33	22950	1	SONALERT, 250V, INTERMITTENT
34	33589	1	BLOWER, ASSY, VH-FRYERS
35	22300	1	LIGHT, PILOT, 250V, ROUND, RED
36	23782	1	SONALERT, 250V, CONTINUOUS BEEP
37	20390	1	SWITCH, VACUUM, ADJUSTABLE
38	24237	1	SWITCH, PLUNGER, 250V, 15A
39	32114	1	BAFFLE FILTER SWITCH, ASSY
40	20298	1	BRAID, COPPER SHIELDING, 15' ROLL
41	20399	1	LIGHT, INDICATOR, ORANGE
42	20398	1	LIGHT, INDICATOR, GREEN
43	23200	1	SWITCH, SNAP ACTION, ROLLER TYPE
44	20008	1	CONNECTOR, 4-PIN, IN-LINE PLUG
45	21290	3	CONNECTOR, PIN, MALE
46	20513	1	BREAKER, CIRCUIT, 277V, 50A, 6 PL, SER TRIP
47	21196	7	TERMINAL, BLOCK, JUMPER
48	21288	1	CONNECTOR, 9 PIN, AMP
49	21289	1	CONNECTOR, 12 PIN, AMP
50	21290	10	CONNECTOR, PIN, MALE

10-16. Wiring Diagram GEF-720-VH 480/60/3 (Computer)

WIRING DIAGRAM GEF-720-VH 480/60/3 DIGITAL TIMER/TEMP CONTROL (COMPUTER)

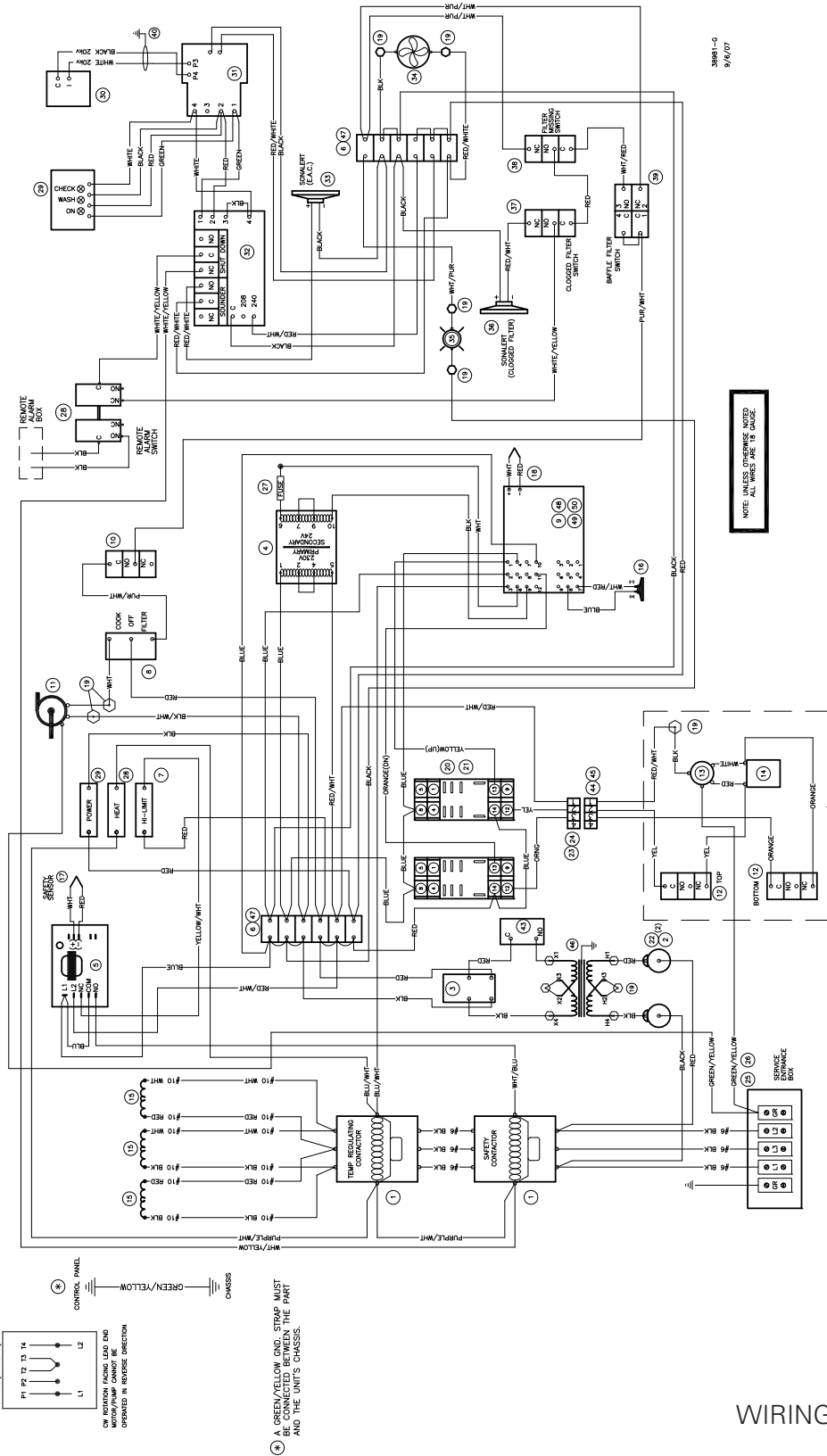

NOTE: UNLESS OTHERWISE NOTED ALL MEASUREMENTS IN INCHES

38981-G
9/9/07

WIRING DIAGRAM P/N:
38981-G

Wiring Diagram

**Model: GEF-400, GEF-560, GEF-720 &
GEF-400-VH, GEF-560-VH, GEF-720-VH**

10-16. BOM for Wiring Diagram GEF-720-VH 480/60/3

Item	Part Number	Qty.	Description
1	32208	2	CONTACTOR, ASSY, 1 PH, 75A, 208/240V
2	21950	2	HOLDER, FUSE, 300V, 15A, SC 0 TO 15
3	21190	1	SWITCH, ROCKER, ON-OFF, 250V, 20A, D.P.
4	20366	1	TRANSFORMER, 20VA, 115/230V, 60HZ, CL2
4	20217	1	TRANSFORMER,25VA,A41,115/230V,50HZ
5	23754	1	THERMOSTAT,HILIMIT,WATLOW,425DEG
6	23751	2	TERMINAL BLOCK, MA106
7	20402	1	LIGHT, INDICATOR, RED
8	21189	1	SWITCH, ROCKER, ON-OFF-ON, 250V,20A,S.P.
9	24241	1	CONTROLLER, WATLOW, ENGLISH
10	21157	1	SWITCH, LIMIT, 15A, 250V DRAIN SWITCH
11	70912	1	PUMP/MOTOR ASSY, VIKING
12	23201	2	SWITCH, SNAP ACTION, ROLLER TYPE
13	20120	1	MOTOR, 230V, ELEVATOR,GEF
14	20122	1	CAPACITOR, 4mfs,370V,GEF
15	20309	3	ELEMENT, 6666W, 240V, GEF-720
15	20306	3	ELEMENT, 6666W, 208V, GEF-720
16	22976	1	AUDIOLARM, BELL TIMER, CONTINUOUS,2-12DC
17	23908	1	THERMOCOUPLE, SAFETY, TYPE J, SINGLE
18	23909	1	THERMOCOUPLE, VARIABLE, TYPE J, SINGLE
19	25275	7	WIRENUT, BLUE
20	20312	2	BASE, RELAY, PLUG-IN, DIN MOUNT
21	20318	2	RELAY, 240 VAC, 10A, ELECTRO-MECH
22	21900	2	FUSE, 15-AMP, SC-15
23	20007	1	CONNECTOR, 4-PIN, IN-LINE RECEPTACLE
24	24291	3	CONNECTOR, PIN, FEMALE
25	20304	2	TERMINAL BLOCK, GROUND, 4-12 GA WIRE
26	20303	3	TERMINAL BLOCK, 4-12 GA WIRE
27	38365	1	ASSY, FUSE, CONTROLLER TRANSFORMER
28	20002	1	SWITCH, ANSUL, SHUTDOWN/ALARM, 15A, 120V
29	24209	1	LED, AIR FILTER, EAC
30	21125	1	BOARD, CONTACT, EAC, VH UNITS
31	24208	1	POWER SUPPLY, EAC, W/DRIVER, 208-240V
32	23776	1	MODULE, AIR FILTER, ALARM & SHUTDOWN
33	22950	1	SONALERT, 250V, INTERMITTENT
34	33589	1	BLOWER, ASSY, VH-FRYERS
35	22300	1	LIGHT, PILOT, 250V, ROUND, RED
36	23782	1	SONALERT, 250V, CONTINUOUS BEEP
37	20390	1	SWITCH, VACUUM, ADJUSTABLE
38	24237	1	SWITCH, PLUNGER, 250V, 15A
39	32114	1	BAFFLE FILTER SWITCH, ASSY
40	20298	1	BRAID, COPPER SHIELDING, 15' ROLL
41	20399	1	LIGHT, INDICATOR, ORANGE
42	20398	1	LIGHT, INDICATOR, GREEN
43	23200	1	SWITCH, SNAP ACTION, ROLLER TYPE
44	20008	1	CONNECTOR, 4-PIN, IN-LINE PLUG
45	21290	3	CONNECTOR, PIN, MALE
46	24277	1	TRANSFORMER, 1.5kw, 480V TO 240V
47	21196	7	TERMINAL, BLOCK, JUMPER
48	21288	1	CONNECTOR, 9 PIN, AMP
49	21289	1	CONNECTOR, 12 PIN, AMP
50	21290	10	CONNECTOR, PIN, MALE

10-17. Wiring Diagram GEF-720-VH 208-240/60/3 W/ UV (Computer)

WIRING DIAGRAM GEF-720-VH 208-240/60/3 AND 220/50/3
COMPUTER CONTROL W/ UV LIGHT

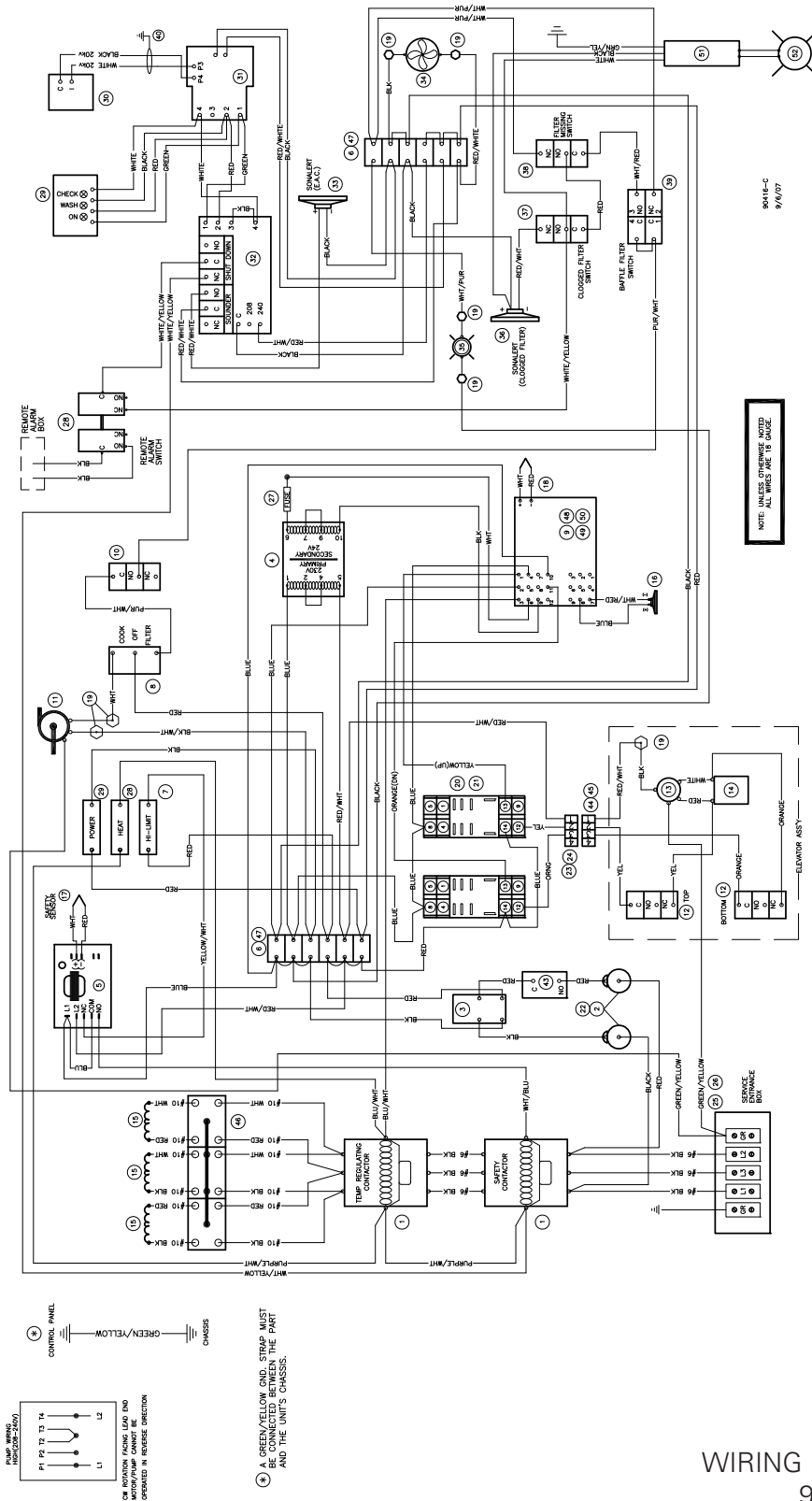

Wiring Diagram

Model: GEF-400, GEF-560, GEF-720 &
GEF-400-VH, GEF-560-VH, GEF-720-VH

10-17. BOM for Wiring Diagram GEF-720-VH 208-240/60/3 W/ UV

Item	Part Number	Qty.	Description
1	32208	2	CONTACTOR, ASSY, 1 PH, 75A, 208/240V
2	21950	2	HOLDER, FUSE, 300V, 15A, SC 0 TO 15
3	21190	1	SWITCH, ROCKER, ON-OFF, 250V, 20A, D.P.
4	20366	1	TRANSFORMER, 20VA, 115/230V, 60HZ, CL2
4	20217	1	TRANSFORMER,25VA,A41,115/230V,50HZ
5	23754	1	THERMOSTAT,HILIMIT,WATLOW,425DEG
6	23751	2	TERMINAL BLOCK, MA106
7	20402	1	LIGHT, INDICATOR, RED
8	21189	1	SWITCH, ROCKER, ON-OFF-ON, 250V,20A,S.P.
9	24241	1	CONTROLLER, WATLOW, ENGLISH
10	21157	1	SWITCH, LIMIT, 15A, 250V DRAIN SWITCH
11	70912	1	PUMP/MOTOR ASSY, VIKING
12	23201	2	SWITCH, SNAP ACTION, ROLLER TYPE
13	20120	1	MOTOR, 230V, ELEVATOR,GEF
14	20122	1	CAPACITOR, 4mfd,370V,GEF
15	20309	3	ELEMENT, 6666W, 240V, GEF-720
15	20306	3	ELEMENT, 6666W, 208V, GEF-720
16	22976	1	AUDIOLARM, BELL TIMER, CONTINUOUS,2-12DC
17	23908	1	THERMOCOUPLE, SAFETY, TYPE J, SINGLE
18	23909	1	THERMOCOUPLE, VARIABLE, TYPE J, SINGLE
19	25275	7	WIRENUT, BLUE
20	20312	2	BASE, RELAY, PLUG-IN, DIN MOUNT
21	20318	2	RELAY, 240 VAC, 10A, ELECTRO-MECH
22	21900	2	FUSE, 15-AMP, SC-15
23	20007	1	CONNECTOR, 4-PIN, IN-LINE RECEPTACLE
24	24291	3	CONNECTOR, PIN, FEMALE
25	20304	2	TERMINAL BLOCK, GROUND, 4-12 GA WIRE
26	20303	3	TERMINAL BLOCK, 4-12 GA WIRE
27	38365	1	ASSY, FUSE, CONTROLLER TRANSFORMER
28	20002	1	SWITCH, ANSUL, SHUTDOWN/ALARM, 15A, 120V
29	24209	1	LED, AIR FILTER, EAC
30	21125	1	BOARD, CONTACT, EAC, VH UNITS
31	24208	1	POWER SUPPLY, EAC, W/DRIVER, 208-240V
32	23776	1	MODULE, AIR FILTER, ALARM & SHUTDOWN
33	22950	1	SONALERT, 250V, INTERMITTENT
34	33589	1	BLOWER, ASSY, VH-FRYERS
35	22300	1	LIGHT, PILOT, 250V, ROUND, RED
36	23782	1	SONALERT, 250V, CONTINOUS BEEP
37	20390	1	SWITCH, VACUUM, ADJUSTABLE
38	24237	1	SWITCH, PLUNGER, 250V, 15A
39	32114	1	BAFFLE FILTER SWITCH, ASSY
40	20298	1	BRAID, COPPER SHIELDING, 15' ROLL
41	20399	1	LIGHT, INDICATOR, ORANGE
42	20398	1	LIGHT, INDICATOR, GREEN
43	23200	1	SWITCH, SNAP ACTION, ROLLER TYPE
44	20008	1	CONNECTOR, 4-PIN, IN-LINE PLUG
45	21290	3	CONNECTOR, PIN, MALE
46	20513	1	BREAKER, CIRCUIT,277V,50A,6 PL, SER TRIP
47	21196	7	TERMINAL, BLOCK, JUMPER
48	21288	1	CONNECTOR, 9 PIN, AMP
49	21289	1	CONNECTOR, 12 PIN, AMP
50	21290	10	CONNECTOR, PIN, MALE
51	20373	1	UV-LAMP, ASSY (BALLAST & LAMP)
52	90226	1	LAMP, ASSY, 16-IN, UV, REPLACEMENT ONLY

10-18. Wiring Diagram GEF-720-VH 480/60/3 W/ UV (Computer)

WIRING DIAGRAM GEF-720-VH 480/60/3
COMPUTER CONTROL W/ UV LIGHT

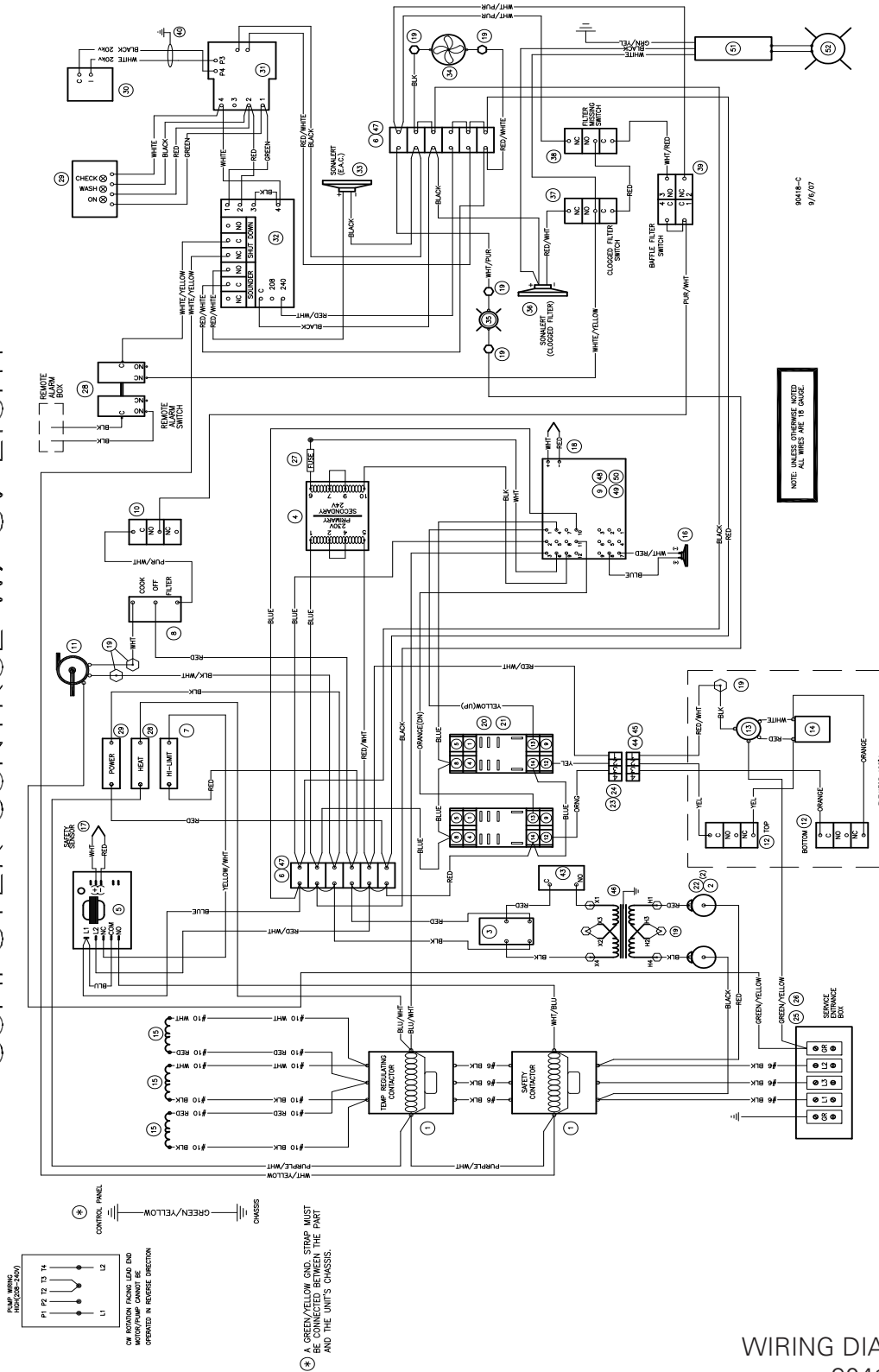

Wiring Diagram

**Model: GEF-400, GEF-560, GEF-720 &
GEF-400-VH, GEF-560-VH, GEF-720-VH**

10-18. BOM for Wiring Diagram GEF-720-VH 480/60/3 W/ UV

Item	Part Number	Qty.	Description
1	32208	2	CONTACTOR, ASSY, 1 PH, 75A, 208/240V
2	21950	2	HOLDER, FUSE, 300V, 15A, SC 0 TO 15
3	21190	1	SWITCH, ROCKER, ON-OFF, 250V, 20A, D.P.
4	20366	1	TRANSFORMER, 20VA, 115/230V, 60HZ, CL2
4	20217	1	TRANSFORMER,25VA,A41,115/230V,50HZ
5	23754	1	THERMOSTAT,HILIMIT,WATLOW,425DEG
6	23751	2	TERMINAL BLOCK, MA106
7	20402	1	LIGHT, INDICATOR, RED
8	21189	1	SWITCH, ROCKER, ON-OFF-ON, 250V,20A,S.P.
9	24241	1	CONTROLLER, WATLOW, ENGLISH
10	21157	1	SWITCH, LIMIT, 15A, 250V DRAIN SWITCH
11	70912	1	PUMP/MOTOR ASSY, VIKING
12	23201	2	SWITCH, SNAP ACTION, ROLLER TYPE
13	20120	1	MOTOR, 230V, ELEVATOR, GEF
14	20122	1	CAPACITOR, 4mfd,370V,GEF
15	20309	3	ELEMENT, 6666W, 240V, GEF-720
15	20306	3	ELEMENT, 6666W, 208V, GEF-720
16	22976	1	AUDIOLARM, BELL TIMER, CONTINUOUS,2-12DC
17	23908	1	THERMOCOUPLE, SAFETY, TYPE J, SINGLE
18	23909	1	THERMOCOUPLE, VARIABLE, TYPE J, SINGLE
19	25275	7	WIRENUT, BLUE
20	20312	2	BASE, RELAY, PLUG-IN, DIN MOUNT
21	20318	2	RELAY, 240 VAC, 10A, ELECTRO-MECH
22	21900	2	FUSE, 15-AMP, SC-15
23	20007	1	CONNECTOR, 4-PIN, IN-LINE RECEPTACLE
24	24291	3	CONNECTOR, PIN, FEMALE
25	20304	2	TERMINAL BLOCK, GROUND, 4-12 GA WIRE
26	20303	3	TERMINAL BLOCK, 4-12 GA WIRE
27	38365	1	ASSY, FUSE, CONTROLLER TRANSFORMER
28	20002	1	SWITCH, ANSUL, SHUTDOWN/ALARM, 15A, 120V
29	24209	1	LED, AIR FILTER, EAC
30	21125	1	BOARD, CONTACT, EAC, VH UNITS
31	24208	1	POWER SUPPLY, EAC, W/DRIVER, 208-240V
32	23776	1	MODULE, AIR FILTER, ALARM & SHUTDOWN
33	22950	1	SONALERT, 250V, INTERMITTENT
34	33589	1	BLOWER, ASSY, VH-FRYERS
35	22300	1	LIGHT, PILOT, 250V, ROUND, RED
36	23782	1	SONALERT, 250V, CONTINUOUS BEEP
37	20390	1	SWITCH, VACUUM, ADJUSTABLE
38	24237	1	SWITCH, PLUNGER, 250V, 15A
39	32114	1	BAFFLE FILTER SWITCH, ASSY
40	20298	1	BRAID, COPPER SHIELDING, 15' ROLL
41	20399	1	LIGHT, INDICATOR, ORANGE
42	20399	1	LIGHT, INDICATOR, GREEN
43	23200	1	SWITCH, SNAP ACTION, ROLLER TYPE
44	20008	1	CONNECTOR, 4-PIN, IN-LINE PLUG
45	21290	3	CONNECTOR, PIN, MALE
46	24277	1	TRANSFORMER, 1.5kw, 480V TO 240V
47	21196	7	TERMINAL, BLOCK, JUMPER
48	21288	1	CONNECTOR, 9 PIN, AMP
49	21289	1	CONNECTOR, 12 PIN, AMP
50	21290	10	CONNECTOR, PIN, MALE
51	20373	1	UV-LAMP, ASSY (BALLAST & LAMP)
52	90226	1	LAMP, ASSY, 16-IN, UV, REPLACEMENT ONLY

**Model: GEF-400, GEF-560, GEF-720 &
GEF-400-VH, GEF-560-VH, GEF-720-VH**

Wiring Diagram



Notes:



Giles Enterprises, Inc.

P.O. Box 210247 • 2750 Gunter Park Drive West • Montgomery, Al 36121-0247 USA
Phone (334) 272-1457 • Service Hotline 1-800-554-4537 (USA & Canada Only) • FAX (334) 272-3561 • www.gilesent.com

Form No. 60831 (Release date: 06/02/03)(Revision Date: 09/06/07)(Rev D)