

Operation Manual and Parts Directory

**Glas
tender®**

MF24, MF36, MF48

MUG FROSTERS AND PLATE CHILLERS



MF24-S



MF48-B2

Glastender, Inc. · 5400 North Michigan Road · Saginaw, MI · 48604-9780
800.748.0423 · 989.752.4275 · Fax 800.838.0888 / 989.752.4444 · www.glastender.com

<u>TOPIC</u>	<u>PAGE</u>
Terms and Conditions	1
Warranty Statement.....	2
Installation.....	3
Operation.....	4
Cleaning Instructions	4
Electrical and Refrigeration Specifications	5
Wiring Diagram	5
Compressor and condenser related parts	6-7
Evaporator and related parts	8
Electrical Components	9
Shelving and related parts.....	10
Doors, tops and related parts	11
Refrigeration compartment covers	12
220 Volt Electrical Parts	13
Installation Notes	13

TERMS AND CONDITIONS

**PRICES:**

All prices are LIST. Applicable taxes will be added.

QUOTATIONS:

Unless otherwise stated, quotations are effective for 30 days only.

ACCEPTANCE:

All orders are subject to acceptance by Glastender, Inc.'s headquarters in Saginaw, Michigan. Possession of the Product Directory and Price List is not an offer to sell.

SHIPMENTS:

F.O.B. factory in Saginaw, Michigan. Freight terms are Third Party or Collect if shipped directly to you. Prepay and Add to Invoice freight terms are available upon request. The approximate shipping weights of all products are listed with the prices. Partial shipments will be made unless otherwise specified by the customer. Surface freight classifications are:

- Glasswashers, Line Chillers - Class 92.5
- Cocktail Stations, Underbar Equipment - Class 85
- Bar Die/Underbar Equipment – Class 125
- Refrigeration Equipment, 48" long or smaller - Class 100
- Refrigeration Equipment, greater than 48" long - Class 110

All small items are evaluated to see the most cost effective means for shipment. Many small items ship via UPS or FedEx; however, when dimensional weight is excessive DB Schenker, UPS Supply Chain, or even common LTL carriers are the most cost effective choice. Spare parts orders received before 1:00 PM EST can usually be shipped the same day.

The order department is happy to assist with routing or shipping questions.

PAYMENT TERMS:

Cash should be included with all orders unless credit terms have been arranged. To establish credit, banking and trade references are required. A convenient credit application is available upon request. Payment via credit card is not our normal means of receiving payment. Visa and MasterCard will be accepted, but must be charged at the time of shipment. In addition, a payment via credit card for orders totaling more than \$500 will incur a 3% convenience fee on the total transaction amount.

DELIVERY:

The majority of equipment is manufactured to order and typically ships within three to six weeks after complete order information is received by the factory. In-stock equipment typically ships within two to three days of the factory receiving complete order information.

RETURNS:

Items specified as "Manufactured to Order" are NOT returnable.

A Return Material Authorization (RMA) number must be issued by the factory in advance for any items that are returnable. The RMA number MUST be noted on the outside of the returned package. Returns must be received within 90 days of the RMA issue date. Shipping charges must be prepaid. A minimum 20% restocking charge will be applied to all authorized returns if received in new, unused condition in the original packaging.

The above conditions apply to spare part returns, except spare part returns must be received within 30 days of original shipment for electronic or electrical parts or within 90 days for all other parts.

LOSS OR DAMAGE:

For customer routed shipments, Glastender, Inc. is not responsible for any loss, damage, or delay of merchandise during shipment. Such transit claims must be filed with the carrier. Merchandise must be examined on arrival. If shortages occur, Glastender, Inc. must be notified in writing within five (5) days of delivery to honor any shortage claim. Glastender will assume responsibility for freight claims on Prepay and Add shipments but the customer must inspect freight and note any damage upon receipt. Failure to do so may result in losses at the customer's expense.

CUSTOM ORDERS:

Custom orders must be paid in advance and are not subject to cancellation.

LAMINATES:

Some products include common, readily available plastic laminates of the customer's selection. There may be an additional charge if uncommon varieties are ordered.

05/18/10

APPLICABLE TO ALL PRODUCTS SOLD WITHIN THE UNITED STATES AND CANADA

LABOR: Glastender, Inc. warrants all products to be free of defects in material and workmanship. In established areas, a start-up and a 90-day labor warranty are included with glasswasher models GT-24 and GT-30. The GT-18 series glasswashers include a 90-day labor warranty. Self-contained refrigeration models, except beer line chillers, include a 1-year labor warranty, for the duration of one year from date of installation or up to 18 months from date of factory shipment, whichever occurs sooner. For warranty labor claims beyond 15 months from the date of factory shipment, proof of date of installation or occupancy must be provided. Authorization for labor must be obtained from Glastender within the warranty period and prior to the service being performed. Labor warranty applies to the United States and Canada only.

PARTS: Within one year from date of installation or 18 months from date of factory shipment, whichever occurs sooner, Glastender, Inc. will replace any part or assembly found defective under normal use and service. Field replacement parts include a warranty of 90 days from date of installation.

FOUR YEAR ADDITIONAL COMPRESSOR WARRANTY: Glastender will warrant to the original user the compressor for all self-contained refrigeration models for an additional four years following the regular one-year warranty period. This plan applies to the compressor only.

A warranty claim form **MUST** accompany all returned defective parts or assemblies. This form **MUST** be completed in full. Failure to do so may result in delay or denial of credit. Any defective part or assembly must be returned to Glastender, Inc., Saginaw, Michigan, with all transportation and delivery charges prepaid. Warranty repairs or replacements will be shipped FOB factory in Saginaw, Michigan. Reimbursement for applicable freight charges covers ground service only.

Glastender provides in-warranty repairs during a service company's regular working days and hours. There is no provision for payment of a premium rate during "overtime" hours. When warranty service is requested during other than normal working hours, the end user will be charged the premium portion of the overtime rate.

The warranty does not cover equipment subjected to accidents, freight damage, alterations from the original design, improper power and/or plumbing hookups, improper chemical use, general misuse, or lack of routine required maintenance as determined by Glastender, Inc. Installation, normal control adjustments, general maintenance, correcting an installation error, or service calls that reveal the unit is functioning normally will not be reimbursed under warranty.

Condenser coils on self-contained refrigeration products must be cleaned regularly. Failure to provide adequate air flow to a refrigeration unit will void the warranty.

Glastender shall not be liable for loss of use, revenue, or profit, or for any other indirect, incidental, special, or consequential damage including, but not limited to, product spoilage or loss.

This warranty is conditioned upon Glastender receiving notice of any defect subject to this warranty within sixty (60) days of its discovery by the end user or dealer. All products are warranted only for the initial place of installation. Removal of a product automatically terminates this warranty.

SECOND YEAR EXTENDED PARTS & LABOR WARRANTY: Glastender's one-year parts and labor warranty on self-contained refrigeration units, excluding beer line chillers, can be extended to two years with the purchase of a two year parts and labor warranty. Specify part number EWR2 (\$150 net price) when ordering.

EXPORT WARRANTY - One year parts only.

EXCLUSION OF WARRANTIES
EXCEPT AS PROVIDED ABOVE, GLASTENDER MAKES NO WARRANTIES, EXPRESS OR IMPLIED, INCLUDING, BUT NOT LIMITED TO, ANY IMPLIED WARRANTY OF MERCHANTABILITY, FITNESS FOR A PARTICULAR PURPOSE OR NON-INFRINGEMENT.

LIMITATION OF REMEDIES AND DAMAGES
If Buyer makes a valid and timely claim as outlined above, Glastender's liability and Buyer's remedies under this agreement will be limited solely to labor charges authorized and/or replacement or credit, at Glastender's option, with respect to Products returned at Buyer's expense within thirty (30) days after warranty repair. GLASTENDER'S LIABILITY WILL IN NO EVENT BE GREATER IN AMOUNT THAN THE PURCHASE PRICE OF THE RETURNED PRODUCTS. GLASTENDER WILL NOT BE LIABLE UNDER ANY CIRCUMSTANCE FOR CONSEQUENTIAL OR INCIDENTAL DAMAGES, INCLUDING, BUT NOT LIMITED TO, LABOR COSTS EXCEPT AS COVERED UNDER OUR WARRANTY, LOST PROFITS OR THE LOSS OF PERISHABLE PRODUCTS RESULTING FROM THE USE OF OR INABILITY TO USE OUR PRODUCTS OR FROM OUR PRODUCTS' INCORPORATION INTO OR BECOMING A COMPONENT OF ANY OTHER PRODUCT. NEITHER PARTY WILL HAVE ANY NEGLIGENCE OR OTHER TORT LIABILITY TO THE OTHER, OR TO ANY THIRD PARTY, ARISING FROM ANY BREACH OF THIS AGREEMENT.

GOVERNING LAW - JURISDICTION
The terms and conditions of an order are to be governed and construed according to the laws of the State of Michigan, without regard to conflict of laws principles. Buyer hereby consents to the jurisdiction and venue of the courts located in Saginaw County, Michigan.

No representative, distributor, dealer, or any other person is authorized to modify this warranty. This warranty replaces all other written or verbal warranties.

NOTE: Glastender, Inc.'s policy of constant quality improvement means that prices, specifications, and policies are subject to change without notice. Questions regarding this warranty should be directed to Glastender's Customer Service Representative.

03/03/10

IMPORTANT!!

Attention Refrigeration Service Companies

Please review the important warranty information on this page. If you believe a service call should be covered by the factory, please call the factory for authorization between 8AM and 5PM EST, Monday through Friday.

INTRODUCTION

This manual describes the operational features of Mug Froster/Plate Chiller models MF24, MF36, and MF48. Please review this information before attempting installation and operation.

Long term, trouble-free service will follow if good housekeeping and maintenance procedures are followed. Thank you for selecting Glastender, Inc. products.

UTILITY REQUIREMENTS AND CONNECTIONS

- **Electrical:** 115 Volt AC, 1 Phase, 60 Hz, 6.7 Full Load Amps. A separate 15 Amp circuit is recommended. A 6-foot grounded cord is included.
- **Plumbing:** None required. Automatic condensate evaporator is included.

UNCRATING AND START-UP INSTRUCTIONS

All Mug Frosters and Plate Chiller models are shipped in one carton. These steps should be followed:

1. If legs or casters are included, bolt them to the base with the bolts provided.
2. Unwrap power cord from base.
3. Position Mug Froster/Plate Chiller and level and/or seal as required (see page 2).
4. Install shelves.
5. Plug into 115 volt AC outlet.
6. Load with mugs, glasses, plates, etc.
7. Your Glastender Mug Froster/Plate Chiller is now ready for use.

SEALING MUG FROSTER AND PLATE CHILLER BASE TO FLOOR

To comply with NSF & health codes. The Mug Froster base must be sealed to the floor using NSF listed sealant. Place a bead of sealant along outer edges of the base and remove excess with disposable towel.



OPERATION

The Mug Froster/Plate Chiller is designed to chill mugs, glasses, plates, etc. that will appear “frosted” when removed. The operating temperature range of 0°F (-18°C) to 35°F (2°C).

The Mug Froster/Plate Chiller should be filled with *dry*, room-temperature mugs, glasses, plates, etc. to allow maximum chilling. During business hours, the Mug Froster/Plate Chiller can be loaded with additional dry, room-temperature mugs, glasses, plates, etc. Allow 30 minutes for chilling.

The Mug Froster/Plate Chiller includes an *automatic defrost* system. Defrosting will occur every six hours for approximately 20 minutes. During the defrost cycle, the fan inside the Mug Froster/Plate Chiller will turn off and a small amount of mist may appear if the top is opened.

There is also a *manual defrost* system controlled by a switch located on the front left bottom of the Mug Froster/Plate Chiller. This is used when there is ice or snow accumulation inside. An end-of-the-day or weekly schedule can be established for the activation of this manual defrost cycle.

When the manual defrost switch is pushed, a light will turn on and the Mug Froster/Plate Chiller will go into a six-hour defrost. After six hours, the Mug Froster/Plate Chiller will resume normal operation.

If the manual defrost switch is accidentally pushed, the defrost cycle can be terminated by unplugging the power cord for three seconds.

CLEANING INSTRUCTIONS

Cleaning is essential to sustaining the integrity of your equipment and preventing corrosion.

ESTIMATED CLEANING TIME: 5 to 10 minutes per unit daily, 30 minutes quarterly

FREQUENCY: Daily cleaning of exterior & door gaskets. Quarterly cleaning of interior, including shelves.

PROCEDURE:

1. A non-chlorine based cleaner or mild detergent and warm water applied with a soft cloth or sponge to all contact surfaces.
2. Immediately rinse off cleaning agent(s), using clean warm water, clean soft cloth or sponge.
3. Dry with a soft clean cloth, removing standing water as soon as possible.

NOTES:

1. Never use hydrochloric acid, wire brushes, steel wool, scrapers, or chlorine based cleaners on stainless steel surfaces, since they will break down the passivity layer and allow corrosion to occur.
2. On stainless steel surfaces, you may use a soft bristle brush or Scotch-Brite® pad for more stubborn stains. Always scrub with the direction of the grain. Follow with a thorough cleaning as described above.
3. Deposits from food preparation must be properly removed. Even hard water deposits will rust stainless steel, if not removed.
4. Repeated cleaning may dry up black-vinyl-clad steel (exterior) surfaces of the cooler. Armor All® or similar product can bring back the shine. Apply the product to a cloth and then rub into the surface, rather than spraying it directly onto the black-vinyl-clad surface.
5. The cooler door gaskets are most often overlooked when cleaning. Failure to clean them regularly will lead to premature failure, since alcohol and moisture build-up breaks down the gasket material.
6. Mug frosters have a manual defrost timer switch on the front near the bottom, which will activate a 6-hour defrost cycle. Depressing the switch before you close for the evening will remove excess frost build-up on the interior liner. This procedure should be done as often as is necessary. It should also be done the night before the quarterly interior cleaning.

ELECTRICAL AND REFRIGERATION SPECIFICATIONS

MODEL (L-to-R LENGTH)	ELECTRICAL	REFRIGERANT		DESIGN PRESSURE	
		TYPE	CHARGE	HIGH	LOW
24", 36", 48"	115V, 1Ph., 60 Hz., 6.7 Amp	R404A	8.5oz.	350	175

WIRING DIAGRAM

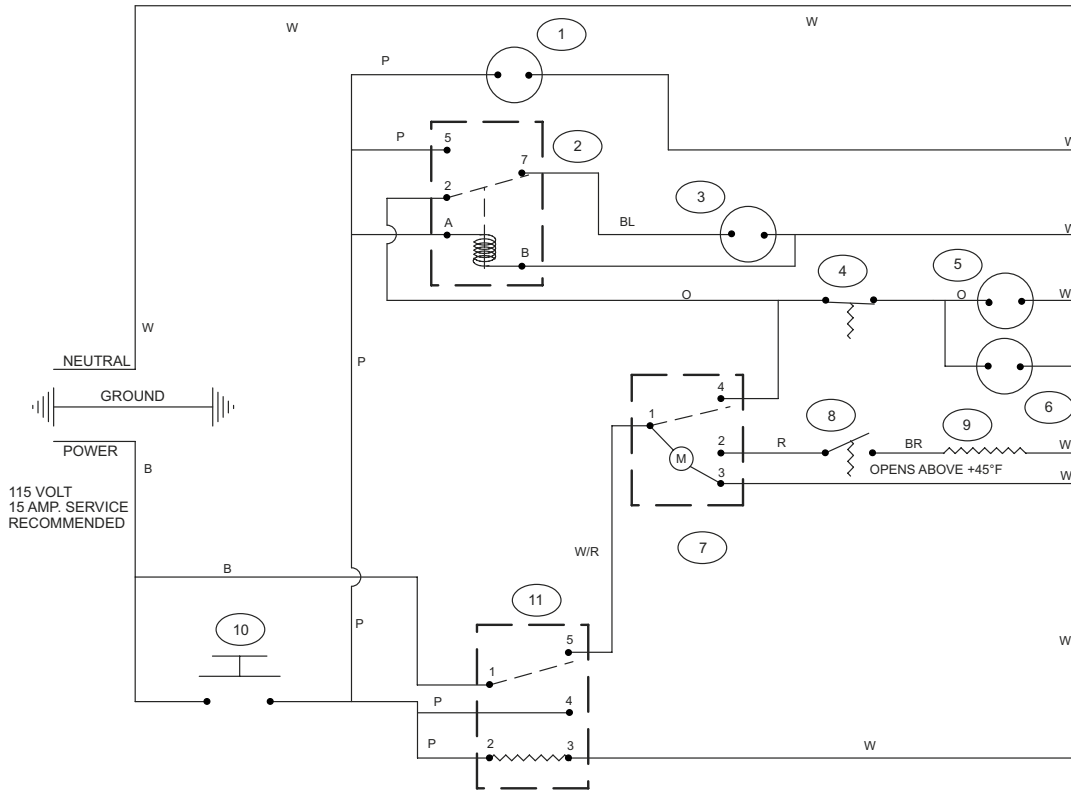

LEGEND

B = Black
BL = Blue
BR = Brown
O = Orange
R = Red
P = Purple
W = White
W/R = White W/ Red

ELECTRICAL RATINGS

115V, Single Phase, 60Hz, 3 wire.
All wires are 16 Gauge

Compressor	5.90 AMP
Condensing Unit Fan Motor	.49 AMP
Evaporator Fan Motor	.28 AMP
TOTAL AMPS	6.67

COMPRESSOR WIRING

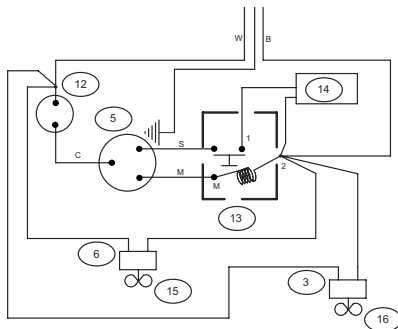

ITEM	DESCRIPTION	PART #
1	6 HR. MANUAL DEFROST LIGHT	07000171
2	EVAPORATOR FAN RELAY	07000166
3	EVAPORATOR FAN	06001445
4	THERMOSTAT	07000621
5	COMPRESSOR, TECUMSEH	07000175
6	CONDENSER FAN MOTOR	06001449
7	AUTOMATIC DEFROST	06001397
8	DEFROST THERMOSTAT	07000165
9	DEFROST HEATER	07000169
10	MANUAL DEFROST SWITCH	07000257
11	6 HR. MANUAL DEFROST	07000156
12	OVERLOAD	07000128
13	START RELAY	07000168
14	CAPACITOR	06001380
15	CONDENSER FAN BLADE	07000155
16	EVAPORATOR FAN BLADE	09000298

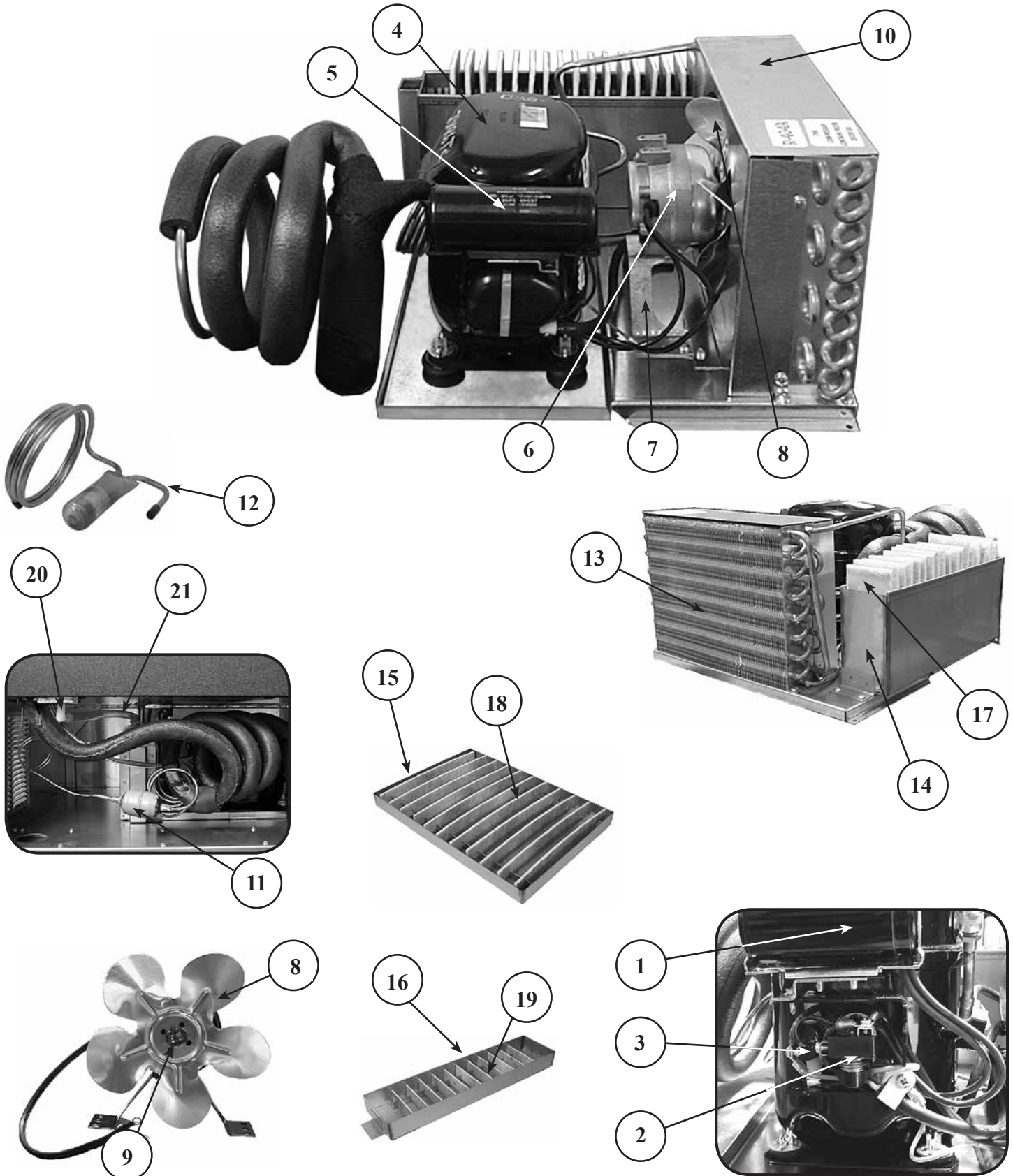

COMPRESSOR AND CONDENSER RELATED PARTS



<u>PART NO.</u>	<u>OLD PART NO.</u>	<u>DESCRIPTION</u>	<u>PRICE</u>
07000258	GT-036350	Condensing Unit, Complete, R404A Aspera	\$900.00
06001639	GT-036351	Condensing Unit, Complete, R404A Tecumseh	980.00
07000173	GT-035008	1/3 HP Aspera compressor, R404A	450.00
1. 07000151	GT-032203	Start capacitor for 1/3 HP R404A Aspera compressor	25.00
2. 06001675	GT-034115	Relay for 1/3 HP R404A Aspera compressor	15.00
3. 07000127		Overload protector for R404 Aspera compressor	15.00
4. 07000175	GT-035026	1/3 HP Tecumseh compressor, R404A (after 1/00)	375.00
5. 06001380	GT-032206	Start capacitor for 1/3 HP R404A Tecumseh compressor	20.00
07000168	GT-034112	Relay for 1/3 HP R404A Tecumseh compressor	18.00
07000128	GT-031207	Overload protector for 1/3 HP R404A Tecumseh compressor	12.00
6. 06001449	GT-035114	Condenser fan motor, 6W	95.00
7. 06001321	GT-031515	Bracket, condenser fan motor mounting	5.00
8. 07000155	GT-032803	Fan blade, condenser, 5 blade	10.00
9. 07000179	GT-035714	Nut, fan blade mounting	1.00
10. 07000152	GT-032302	Fan shroud, condenser	15.00
11. 06001385		Filter dryer, 1/4" x 1/4"	20.00
12. 06001384	GT-032501	Suction line accumulator	40.00
13. 08000078	GT-032607	Condenser coil	145.00
14. 07000230	GT-038016	Pan, condensate, MF24, MF36 and MF48 (after 1998)	70.00
15. 07000260	GT-038001	Pan, condensate, MF36 and MF48 (prior to 1998)	65.00
16. 08000125	GT-038006	Pan, condensate, MF24 (prior to 1998)	60.00
17. 07000237	GT-038207	Wicking material, consists of 14 - 2 1/2" x 6" pieces, MF24, 36 & 48 (after 1998)	34.00
18. 07000234	GT-038201	Wicking material, consists of 11 9" pieces, MF36 & MF48 (prior to 1998)	24.00
19. 07000235	GT-038203	Wicking material, consists to 11 4" pieces, MF24 (prior to 1998)	14.00
20. 06001461	GT-035290	Elbow, 1/2" x 1/2" plastic barb	2.00
21. 06001345	GT-031716	Tubing, drain, clear plastic. 1/2" ID x 5/8" OD, per foot	1.45
06001313	GT-031400	Condensing unit power cord	20.00
07000724		Tubing, capillary, .049x64"	20.00

PART NO.	OLD PART NO.	DESCRIPTION	PRICE
1. 07000310	GT-031514	Bracket, evaporator fan motor	\$14.00
2. 07000134	GT-031516	Temperature control mounting bracket, prior to SN 404104830N	10.00
3. 07000153	GT-032303	Evaporator fan box back, prior to SN 404104830N	24.00
07000362		Cover, evaporator back, SN 404104830N and after	24.00
4. 07000380		Evaporator coil replacement kit	180.00
5. 09000298	GT-032804	Fan blade, evaporator, 5 blade	5.00
6. 07000621		Thermostat, includes knob, plate, and tubing	50.00
7. 07000165	GT-033413	Defrost sensor	26.00
8. 07000169	GT-034704	Defrost heater	60.00
9. 06001445	GT-035107	Fan motor, evaporator	35.00
10. 07000182	GT-036100	Cover, front, evaporator, MF24, MF36, prior to SN 404104830N	54.00
07000184	GT-036102	Cover, front, evaporator, MF48, prior to SN 404104830N	54.00
07000364		Cover, front, evaporator, MF24, MF36, MF48, SN 404104830N and after	54.00
07000183	GT-036101	Cover, bottom, evaporator, MF24, MF36, prior to SN 404104830N	42.00
07000360		Cover, bottom, evaporator, MF24, MF36, SN 404104830N and after	42.00
07000185	GT-036103	Cover, bottom, evaporator, MF48, prior to SN 404104830N	42.00
07000361		Cover, bottom, evaporator, MF48, SN 404104830N and after	42.00
11. 07000228	GT-037420	Evaporator housing, prior to SN 404104830N	60.00
07000365		Drain pan, evaporator MF24, MF36, SN 404104830N and after	60.00
07000366		Drain pan, evaporator MF48, SN 404104830N and after	60.00
12. 06001573	GT-038725	10-32" x 1/2" thumbscrew (4 required) (2 req prior to SN 404104830N)	1.00

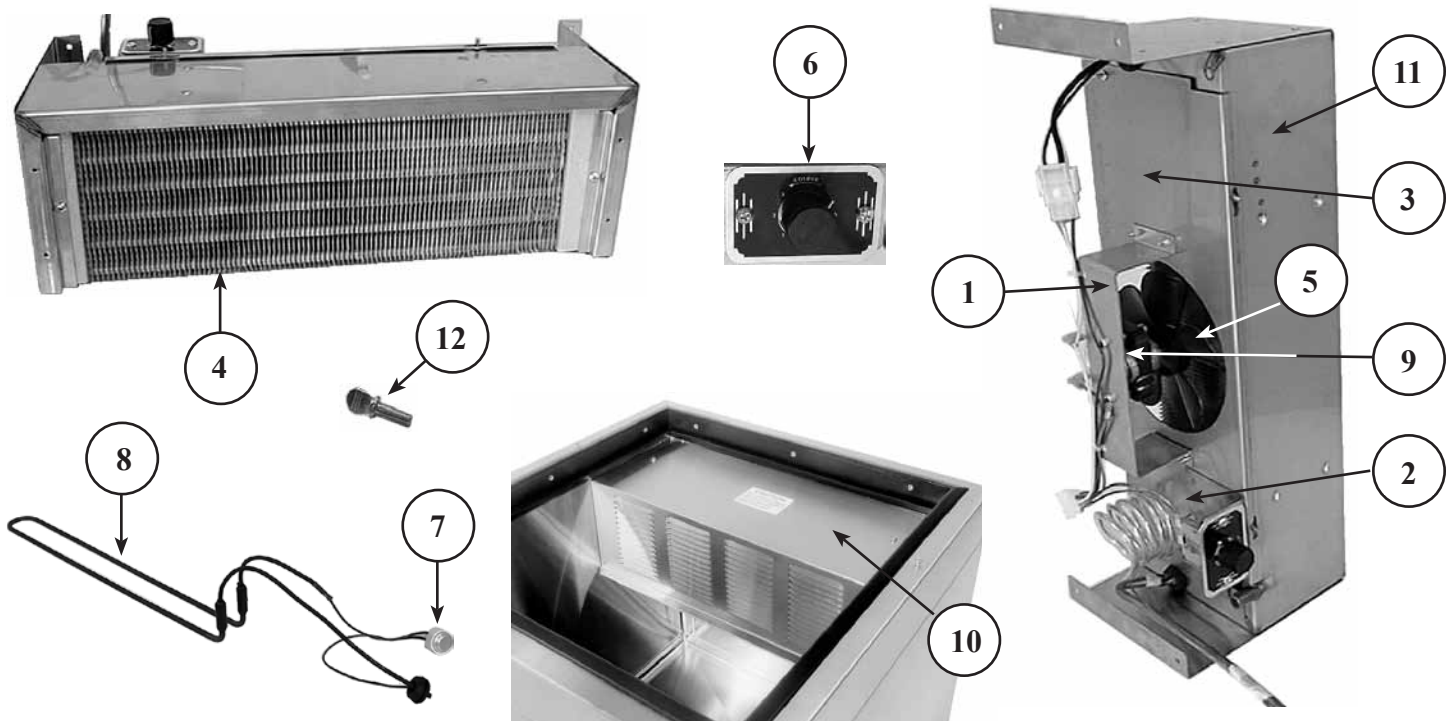

ELECTRICAL COMPONENTS



<u>PART NO.</u>	<u>OLD PART NO.</u>	<u>DESCRIPTION</u>	<u>PRICE</u>
1. 06001314	GT-031401	Exterior power cord, 11'	\$35.00
07000599		Replacement powercord assembly, includes (06001572 01000669 06001314)	40.00
2. 07000246	GT-031608	Decal, control module	7.00
3. 06001397	GT-033000	Automatic defrost	32.00
4. 07000156	GT-033001	Manual defrost timer (6 hr)	90.00
5. 01000547	GT-033301	Receptacle, 3 wire, mate-n-lok	1.00
6. 06001634	GT-033302	Receptacle, 6 wire, mate-n-lok	1.50
7. 06001409	GT-033304	Receptacle, compressor	5.00
8. 07000257	GT-033401	Manual defrost switch	20.00
9. 07000166	GT-034105	Evaporator fan relay	40.00
10. 07000171	GT-034907	Manual defrost light, red	10.00
11. 07000176	GT-035519	Wiring harness, control module	50.00
12. 07000227	GT-037419	Control module, complete	400.00

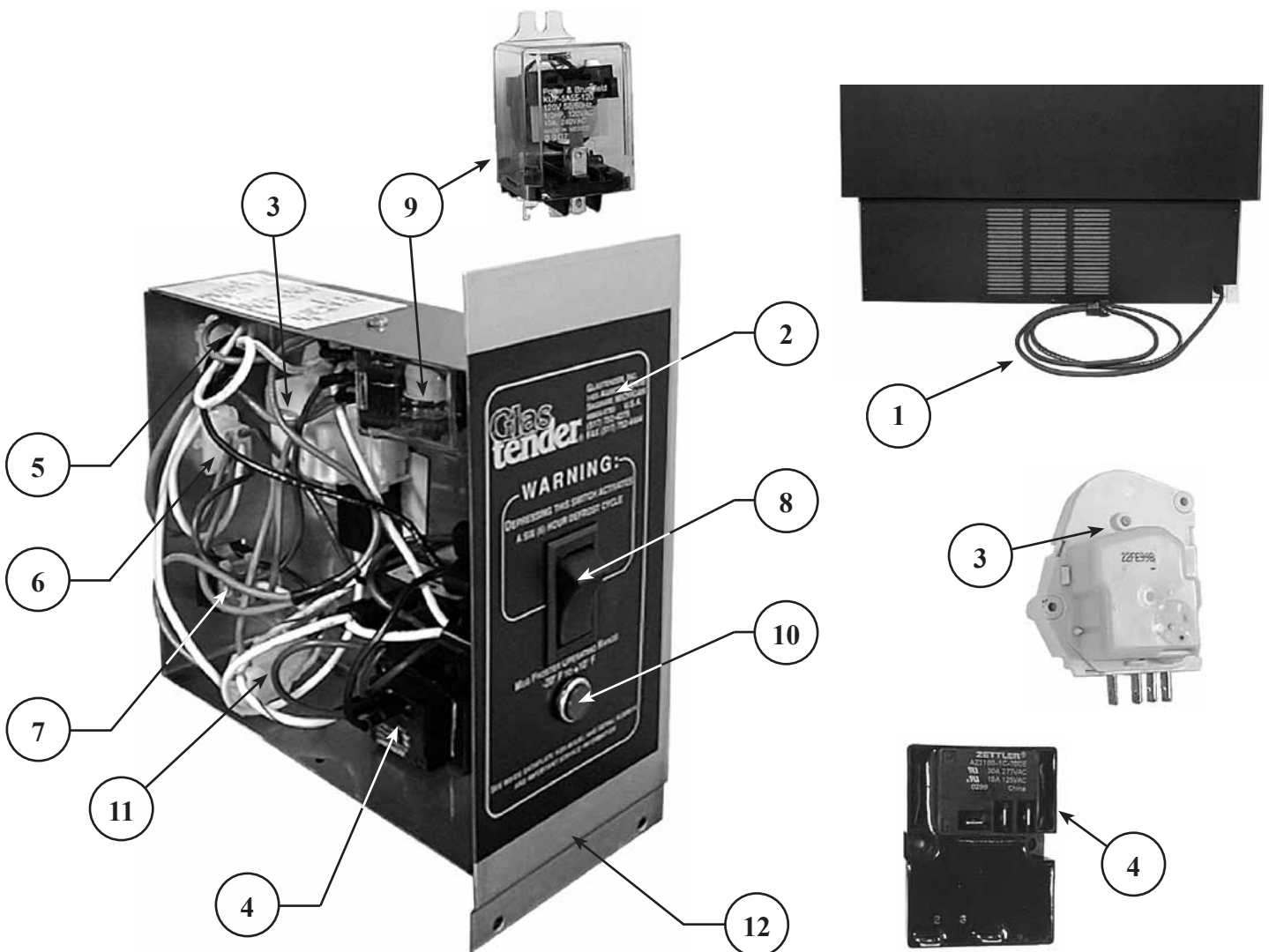

PART NO.	OLD PART NO.	DESCRIPTION	PRICE
1. 07000030	GT-031517	10" shelf bracket (MF36 = 1) (MF48 = 2 prior to SN 404104830N)	\$6.00
2. 07000029	GT-031518	20" shelf bracket (MF24 = 3)	12.00
07000371		24" shelf bracket (MF48 = 1 SN 404104830N and after)	14.00
3. 07000135	GT-031519	32" shelf bracket (MF36 = 3)	15.00
4. 07000136	GT-031520	44" shelf bracket (MF48 = 3)	18.00
5. 07000159	GT-033104	Shelf, 19-5/8" x 19-5/8" [MF24 = 1 (bottom), MF36 = 1 (bottom), MF48 = 2 (bottom)]	50.00
6. 07000160	GT-033105	Shelf, 9-13/16" x 19-5/8" [MF24 = 2 (middle), MF36 = 2 (middle), MF48 = 2 (middle)]	35.00
7. 07000158	GT-033100	Shelf, 4" x 19-5/8" [MF48 = 1 (bottom)]	35.00
8. 07000161	GT-033107	Shelf, 9-13/16" x 12-1/8" [MF24 = 2 (top), MF36 = 2 (top), MF48 = 2 (top)]	30.00
9. 07000162	GT-033108	Shelf, 12" x 19-5/8" [MF36 = 3 (bottom, middle, top), MF48 = 4 (middle, top)]	40.00
10. 06001573	GT-038725	10/32" x 1/2" thumbscrew	1.00
Complete Shelf Kits			
07000223	GT-036918	Complete shelf kit for MF24 (includes: 1 - 07000159, 2 - 07000160, 2 - 07000161)	180.00
07000224	GT-036919	Complete shelf kit for MF36 (includes: 1- 07000159, 2 - 07000160, 2 - 07000161, 3 - 07000162)	300.00
07000225	GT-036920	Complete shelf kit for MF48 (includes: 2 - 07000159, 2 - 07000160, 1- 07000158, 2 - 07000161, 4 - 07000162)	425.00

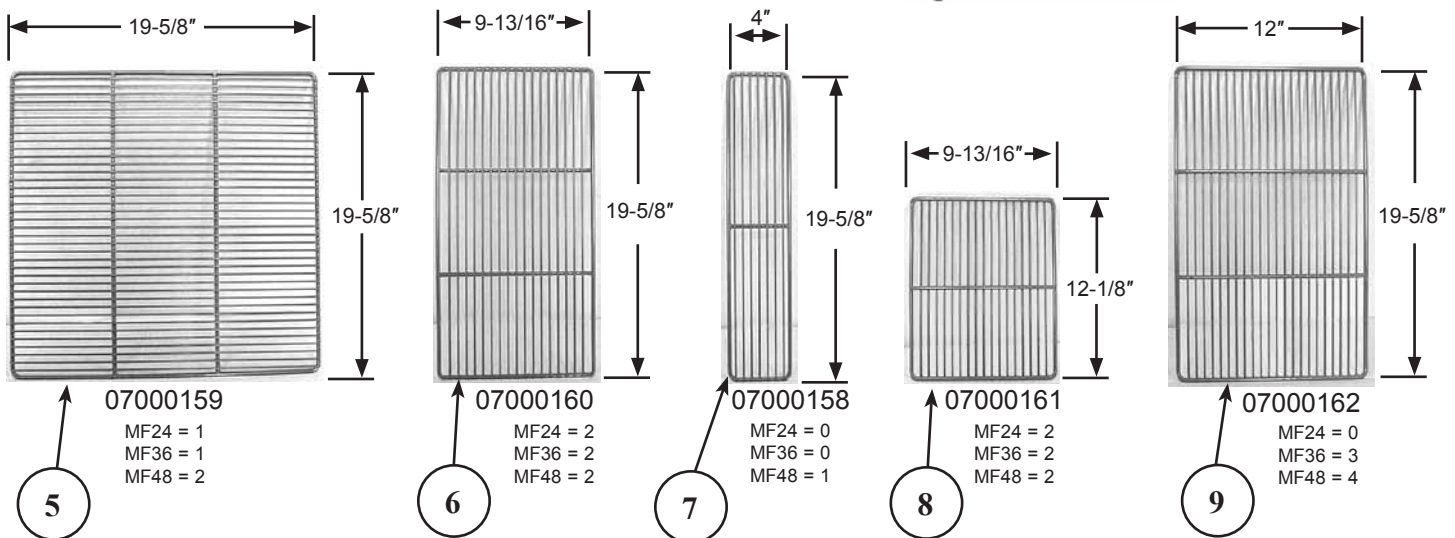
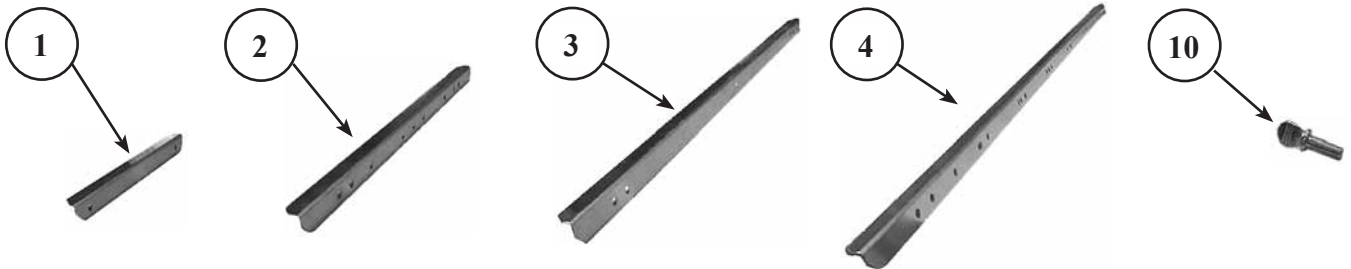

DOORS, TOPS, AND RELATED PARTS



	<u>PART NO.</u>	<u>OLD PART NO.</u>	<u>DESCRIPTION</u>	<u>PRICE</u>
	07000129	GT-031311	Gasket, wiper, 24" top, 21-1/2" long	\$10.00
1.	07000130	GT-031312	Gasket, wiper, 36" top, 33-1/2" long	14.00
	07000212	GT-036213	Sliding door, 21", MF24 (for permanent breaker strip models, 1993 only)	120.00
	07000213	GT-036214	Sliding door, 20-3/16", MF24	126.00
	07000261	GT-036215	Sliding door, 33", MF36 (for permanent breaker strip models, 1993 only)	180.00
2.	07000214	GT-036216	Sliding door, 32-3/16", MF36	192.00
	07000231	GT-038113	Top, MF24	126.00
3.	07000232	GT-038114	Top, MF36	192.00
	07000233	GT-038115	Top, MF48	252.00
	07000238	GT-038437	Breaker strip, 24" and 48" sliding door opening, 4 pieces	25.00
4.	07000239	GT-038438	Breaker strip, 36" sliding door opening, 4 pieces	35.00



<u>PART NO.</u>	<u>OLD PART NO.</u>	<u>DESCRIPTION</u>	<u>PRICE</u>
07000186	GT-036105	Front, black vinyl-clad, MF24	\$33.00
07000187	GT-036106	Front, stainless steel, MF24	48.00
07000188	GT-036107	Front, black vinyl-clad, MF36	44.00
07000189	GT-036108	Front, stainless steel, MF36	72.00
1. 07000190	GT-036109	Front, black vinyl-clad, MF48	55.00
07000191	GT-036110	Front, stainless steel, MF48	96.00
07000192	GT-036111	Back, black vinyl-clad, MF24	40.00
07000193	GT-036112	Back, stainless steel, MF24	80.00
07000194	GT-036113	Back, black vinyl-clad, MF36	50.00
07000195	GT-036114	Back, stainless steel, MF36	100.00
2. 07000196	GT-036115	Back, black vinyl-clad, MF48	55.00
07000197	GT-036116	Back, stainless steel, MF48	96.00
3. 07000198	GT-036117	Side, left, black vinyl-clad, all models	40.00
07000199	GT-036118	Side, left, stainless steel, all models	80.00
4. 07000200	GT-036119	Side, right, black vinyl-clad, all models	40.00
07000201	GT-036120	Side, right, stainless steel, all models	80.00

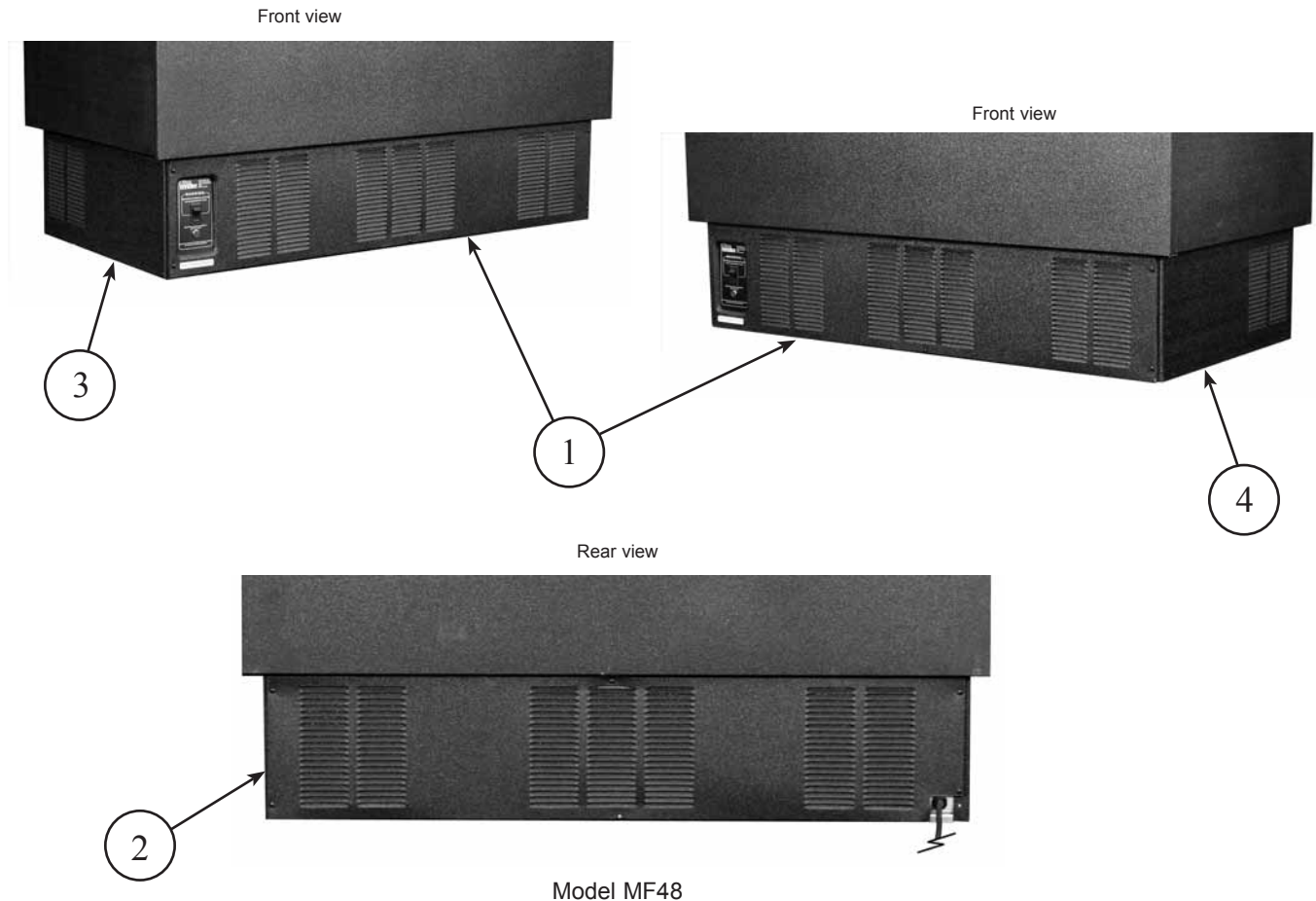

UNPARALLELED UNDERBAR DESIGN & ENGINEERING

Expect more



more flexibility

more features



**Glas
tender**®

Glastender has the most complete line of bar equipment and the ability to manufacture custom units, giving you virtually unlimited design flexibility. Each piece of equipment is engineered with features that enhance your efficiency, ease your maintenance, and prolong the life of your investment.

The flexibility you want. The features you need.

Glastender. Expect more.

GLASSWASHERS • COCKTAIL STATIONS • COOLERS • FROSTERS • BEER SYSTEMS