

Operation Manual and Parts Directory



FRA-24, FRA-36, FRB-24, FRB-36, DI-FR, DI-FR-DW, DI-FR36, DI-FR36-FL,
DI-FR36-DW, DI-FR36-DW-FL

ICE CREAM FREEZERS



DI-FR-DW



FRA-24

Glastender, Inc. · 5400 North Michigan Road · Saginaw, MI · 48604-9780
800.748.0423 · 989.752.4275 · Fax 800.838.0888 / 989.752.4444 · www.glastender.com

Terms and Conditions	1	Uncrating and Start-Up Instructions.....	4
Warranty.....	2	Drop-In Model Installation Instructions	4
Utility Requirements and Connections.....	3	Replacement Parts.....	5-6
Operation.....	3	Wiring Diagram	5
Cleaning Instructions	3		

IMPORTANT !! - Attention Service Companies

Please review the important warranty information on page 2 of this manual. If labor warranty applies, authorization must be obtained from the factory prior to the service being performed. Please call the factory between 8:00AM and 5:00PM EST, Monday through Friday.

TERMS AND CONDITIONS

PRICES:

All prices are LIST. Applicable taxes will be added.

QUOTATIONS:

Unless otherwise stated, quotations are effective for 30 days only.

ACCEPTANCE:

All orders are subject to acceptance by Glastender, Inc.'s headquarters in Saginaw, Michigan. Possession of the Product Directory and Price List is not an offer to sell.

SHIPMENTS:

F.O.B. factory in Saginaw, Michigan. Freight terms are Third Party or Collect if shipped directly to you. Prepay and Add to Invoice freight terms are available upon request. The approximate shipping weights of all products are listed with the prices. Partial shipments will be made unless otherwise specified by the customer. Surface freight classifications are:

- Glasswashers, Line Chillers - Class 92.5
- Cocktail Stations, Underbar Equipment - Class 85
- Bar Die/Underbar Equipment - Class 125
- Refrigeration Equipment, 48" long or smaller - Class 100
- Refrigeration Equipment, greater than 48" long - Class 110

All small items are evaluated to see the most cost effective means for shipment. Many small items ship via UPS or FedEx; however, when dimensional weight is excessive DB Schenker, UPS Supply Chain, or even common LTL carriers are the most cost effective choice. Spare parts orders received before 1:00 PM EST can usually be shipped the same day.

The order department is happy to assist with routing or shipping questions.

PAYMENT TERMS:

Cash should be included with all orders unless credit terms have been arranged. To establish credit, banking and trade references are required. A convenient credit application is available upon request. Payment via credit card is not our normal means of receiving payment. Visa and MasterCard will be accepted, but must be charged at the time of shipment. In addition, a payment via credit card for orders totaling more than \$500 will incur a 3% convenience fee on the total transaction amount.

DELIVERY:

The majority of equipment is manufactured to order and typically ships within three to six weeks after complete order information is received by the factory. In-stock equipment typically ships within two to three days of the factory receiving complete order information.

RETURNS:

Items specified as "Manufactured to Order" are NOT returnable.

A Return Material Authorization (RMA) number must be issued by the factory in advance for any items that are returnable. The RMA number MUST be noted on the outside of the returned package. Returns must be received within 90 days of the RMA issue date. Shipping charges must be prepaid. A minimum 20% restocking charge will be applied to all authorized returns if received in new, unused condition in the original packaging.

The above conditions apply to spare part returns, except spare part returns must be received within 30 days of original shipment for electronic or electrical parts or within 90 days for all other parts.

LOSS OR DAMAGE:

For customer routed shipments, Glastender, Inc. is not responsible for any loss, damage, or delay of merchandise during shipment. Such transit claims must be filed with the carrier. Merchandise must be examined on arrival. If shortages occur, Glastender, Inc. must be notified in writing within five (5) days of delivery to honor any shortage claim. Glastender will assume responsibility for freight claims on Prepay and Add shipments but the customer must inspect freight and note any damage upon receipt. Failure to do so may result in losses at the customer's expense.

CUSTOM ORDERS:

Custom orders must be paid in advance and are not subject to cancellation.

LAMINATES:

Some products include common, readily available plastic laminates of the customer's selection. There may be an additional charge if uncommon varieties are ordered.

05/18/10

Visit our web site for current specification sheets, operations manuals, parts directories and price lists

WARRANTY STATEMENT



APPLICABLE TO ALL PRODUCTS SOLD WITHIN THE UNITED STATES AND CANADA

LABOR: Glastender, Inc. warrants all products to be free of defects in material and workmanship. In established areas, a start-up and a 90-day labor warranty are included with glasswasher models GT-24 and GT-30. The GT-18 series glasswashers include a 90-day labor warranty. Self-contained refrigeration models, except beer line chillers, include a 1-year labor warranty, for the duration of one year from date of installation or up to 18 months from date of factory shipment, whichever occurs sooner. For warranty labor claims beyond 15 months from the date of factory shipment, proof of date of installation or occupancy must be provided. Authorization for labor must be obtained from Glastender within the warranty period and prior to the service being performed. Labor warranty applies to the United States and Canada only.

PARTS: Within one year from date of installation or 18 months from date of factory shipment, whichever occurs sooner, Glastender, Inc. will replace any part or assembly found defective under normal use and service. Field replacement parts include a warranty of 90 days from date of installation.

FOUR YEAR ADDITIONAL COMPRESSOR WARRANTY: Glastender will warrant to the original user the compressor for all self-contained refrigeration models for an additional four years following the regular one-year warranty period. This plan applies to the compressor only.

A warranty claim form **MUST** accompany all returned defective parts or assemblies. This form **MUST** be completed in full. Failure to do so may result in delay or denial of credit. Any defective part or assembly must be returned to Glastender, Inc., Saginaw, Michigan, with all transportation and delivery charges prepaid. Warranty repairs or replacements will be shipped FOB factory in Saginaw, Michigan. Reimbursement for applicable freight charges covers ground service only.

Glastender provides in-warranty repairs during a service company's regular working days and hours. There is no provision for payment of a premium rate during "overtime" hours. When warranty service is requested during other than normal working hours, the end user will be charged the premium portion of the overtime rate.

The warranty does not cover equipment subjected to accidents, freight damage, alterations from the original design, improper power and/or plumbing hookups, improper chemical use, general misuse, or lack of routine required maintenance as determined by Glastender, Inc. Installation, normal control adjustments, general maintenance, correcting an installation error, or service calls that reveal the unit is functioning normally will not be reimbursed under warranty.

Condenser coils on self-contained refrigeration products must be cleaned regularly. Failure to provide adequate air flow to a refrigeration unit will void the warranty.

Glastender shall not be liable for loss of use, revenue, or profit, or for any other indirect, incidental, special, or consequential damage including, but not limited to, product spoilage or loss.

This warranty is conditioned upon Glastender receiving notice of any defect subject to this warranty within sixty (60) days of its discovery by the end user or dealer. All products are warranted only for the initial place of installation. Removal of a product automatically terminates this warranty.

SECOND YEAR EXTENDED PARTS & LABOR WARRANTY:

Glastender's one-year parts and labor warranty on self-contained refrigeration units, excluding beer line chillers, can be extended to two years with the purchase of a two year parts and labor warranty. Specify part number EWR2 (\$150 net price) when ordering.

EXPORT WARRANTY - One year parts only.

EXCLUSION OF WARRANTIES

EXCEPT AS PROVIDED ABOVE, GLASTENDER MAKES NO WARRANTIES, EXPRESS OR IMPLIED, INCLUDING, BUT NOT LIMITED TO, ANY IMPLIED WARRANTY OF MERCHANTABILITY, FITNESS FOR A PARTICULAR PURPOSE OR NON-INFRINGEMENT.

LIMITATION OF REMEDIES AND DAMAGES

If Buyer makes a valid and timely claim as outlined above, Glastender's liability and Buyer's remedies under this agreement will be limited solely to labor charges authorized and/or replacement or credit, at Glastender's option, with respect to Products returned at Buyer's expense within thirty (30) days after warranty repair. GLASTENDER'S LIABILITY WILL IN NO EVENT BE GREATER IN AMOUNT THAN THE PURCHASE PRICE OF THE RETURNED PRODUCTS. GLASTENDER WILL NOT BE LIABLE UNDER ANY CIRCUMSTANCE FOR CONSEQUENTIAL OR INCIDENTAL DAMAGES, INCLUDING, BUT NOT LIMITED TO, LABOR COSTS EXCEPT AS COVERED UNDER OUR WARRANTY, LOST PROFITS OR THE LOSS OF PERISHABLE PRODUCTS RESULTING FROM THE USE OF OR INABILITY TO USE OUR PRODUCTS OR FROM OUR PRODUCTS' INCORPORATION INTO OR BECOMING A COMPONENT OF ANY OTHER PRODUCT. NEITHER PARTY WILL HAVE ANY NEGLIGENCE OR OTHER TORT LIABILITY TO THE OTHER, OR TO ANY THIRD PARTY, ARISING FROM ANY BREACH OF THIS AGREEMENT.

GOVERNING LAW - JURISDICTION

The terms and conditions of an order are to be governed and construed according to the laws of the State of Michigan, without regard to conflict of laws principles. Buyer hereby consents to the jurisdiction and venue of the courts located in Saginaw County, Michigan.

No representative, distributor, dealer, or any other person is authorized to modify this warranty. This warranty replaces all other written or verbal warranties.

NOTE: Glastender, Inc.'s policy of constant quality improvement means that prices, specifications, and policies are subject to change without notice. Questions regarding this warranty should be directed to Glastender's Customer Service Representative.

03/03/10

IMPORTANT!!

Attention Refrigeration Service Companies

Please review the important warranty information on this page. If you believe a service call should be covered by the factory, please call the factory for authorization between 8AM and 5PM EST, Monday through Friday.

This manual describes the operation features of the Ice Cream Freezer. Please review this information before attempting installation and operation.

Long term, trouble-free operation will follow if good housekeeping and maintenance procedures are followed. Thank you for selecting Glastender, Inc. products.

UTILITY REQUIREMENTS AND CONNECTIONS

Electrical: 115 Volt AC, 1 Phase, 60 Hz, 4.68 full load amps. A dedicated 15 amp circuit is recommended. A 6-foot grounded cord is included.

Plumbing:

1. Without dipper well - none required.
2. With dipper well-
 - Drain: 1-1/2" PVC tailpiece provided.
 - Water Supply: 3/8" chrome riser provided.

OPERATION

The Ice Cream Freezer is designed to store ice cream. The FRA-24, FRB-24, and DI-FR models hold one 3-gallon container and the FRA-36, FRB-36, and DI-FR36 models hold two 3-gallon containers. The operating temperature range is -5°F (-21°C) to 10°F (-12°C).

CLEANING INSTRUCTIONS

ESTIMATED CLEANING TIME: 5 to 10 minutes per unit daily.

FREQUENCY: Daily cleaning of exterior & door gaskets. Interior thawing and cleaning as necessary.

PROCEDURE:

1. A non-chlorine based cleaner or mild detergent and warm water applied with a soft cloth or sponge to all contact surfaces.
2. Immediately rinse off cleaning agent(s), using clean warm water, clean soft cloth or sponge.
3. Dry with a soft clean cloth, removing standing water as soon as possible.

NOTES:

1. Never use hydrochloric acid, wire brushes, steel wool, scrapers, or chlorine based cleaners on stainless steel surfaces, since they will break down the passivity layer and allow corrosion to occur.
2. On stainless steel surfaces, you may use a soft bristle brush or Scotch-Brite[®] pad for more stubborn stains. Always scrub with the direction of the grain. Follow with a thorough cleaning as described above.
3. Deposits from food preparation must be properly removed. Even hard water deposits will rust stainless steel, if not removed.
4. Door gaskets are most often overlooked when cleaning. Failure to clean them regularly will lead to premature failure, since alcohol, debris, and moisture build-up breaks down the gasket material.
5. When excess frost builds up on the interior liner, store ice cream in the kitchen freezer and unplug the unit for the night. First thing the next morning, clean the interior, using a sponge to soak up excess moisture.
6. NEVER use a pick or sharp object to remove frost from the interior liner.

UNCRATING AND START-UP INSTRUCTIONS



Ice Cream Freezer models are shipped in one carton. These steps should be followed:

1. If legs are included, bolt them to the base with bolts provided.
2. Unwrap power cord.
3. Position unit and level.
4. Plug into 115 volt AC outlet.
5. Your Glastender equipment is now ready for use.

DROP-IN MODEL INSTALLATION INSTRUCTIONS

PLAN VIEWS

<p>CUT-OUT DIMENSION 14-3/4" X 14-3/4"</p>	<p>CUT-OUT DIMENSION 22-3/4" X 14-3/4"</p>	<p>CUT-OUT DIMENSION 24-3/4" X 14-3/4"</p>	<p>CUT-OUT DIMENSION 32-3/4" X 14-3/4"</p>
DI-FR	DI-FR-DW	DI-FR36 DI-FR36-FL	DI-FR36-DW DI-FR36-DW-FL

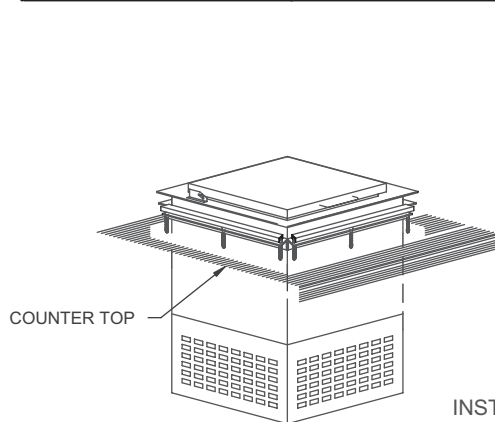

DI-FR

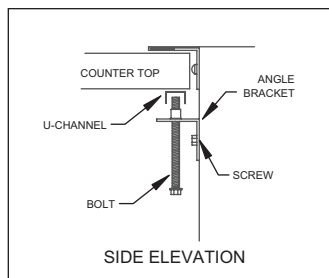

INSTALLATION INSTRUCTIONS

1. Remove angle brackets from drop-in ice cream freezer.
2. Place freezer into appropriate size cut-out for specific model number used.
3. Replace angle brackets, firmly tighten screws.
4. Place U-channels on top of bolts.
5. Tighten each bolt evenly along U-channels.
6. Seal as necessary.

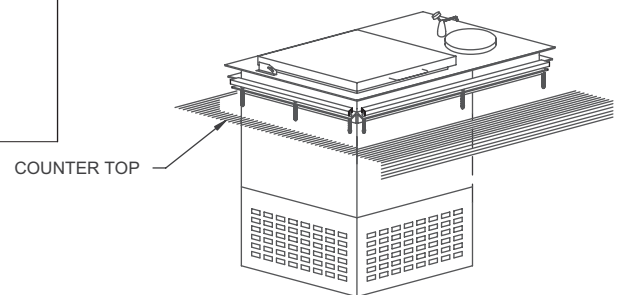

DI-FR-DW

NOTE: AIR FLOW RESTRICTION WILL CAUSE COMPRESSOR FAILURE AND VOID WARRANTY.

REPLACEMENT PARTS

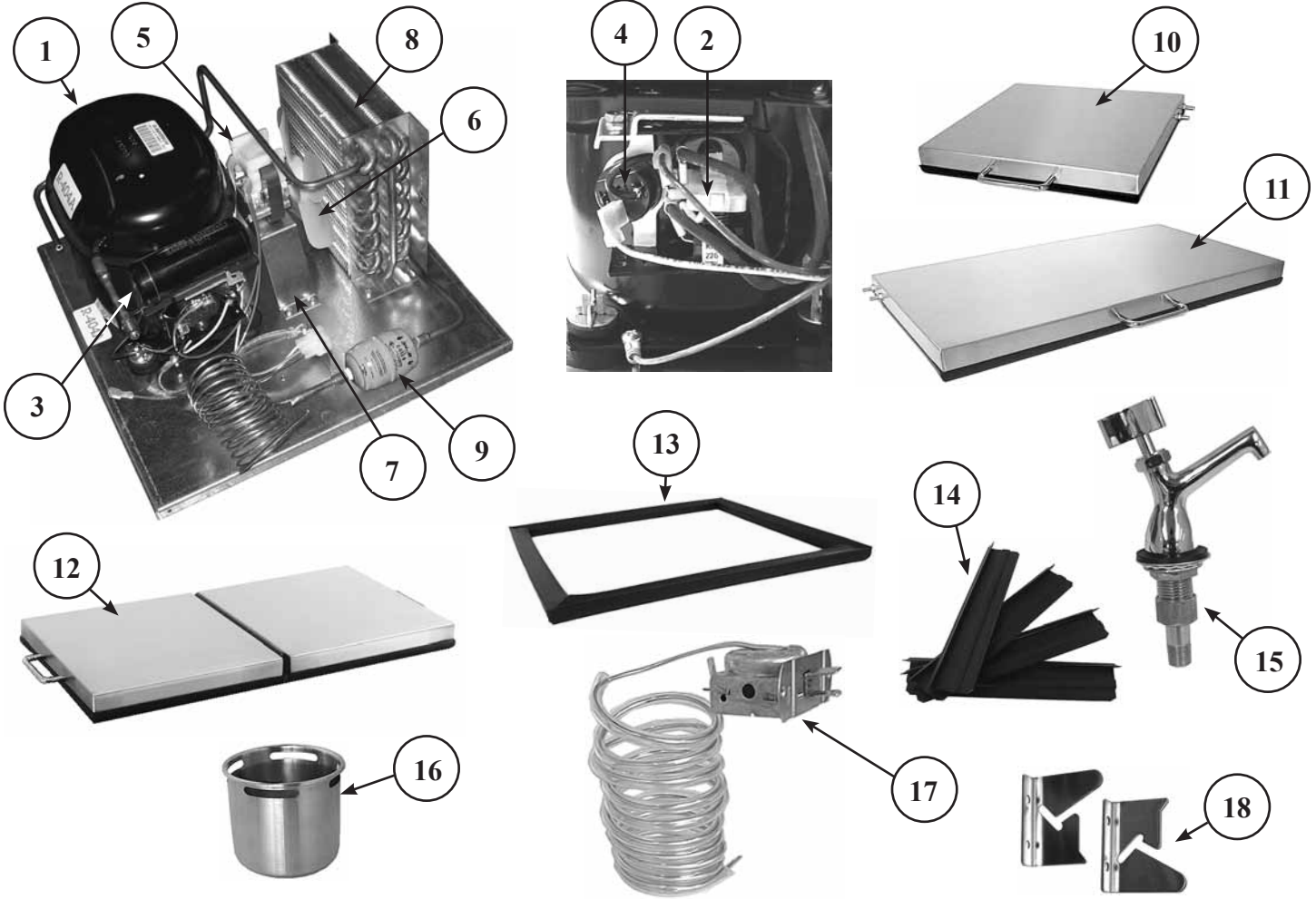

WIRING DIAGRAM

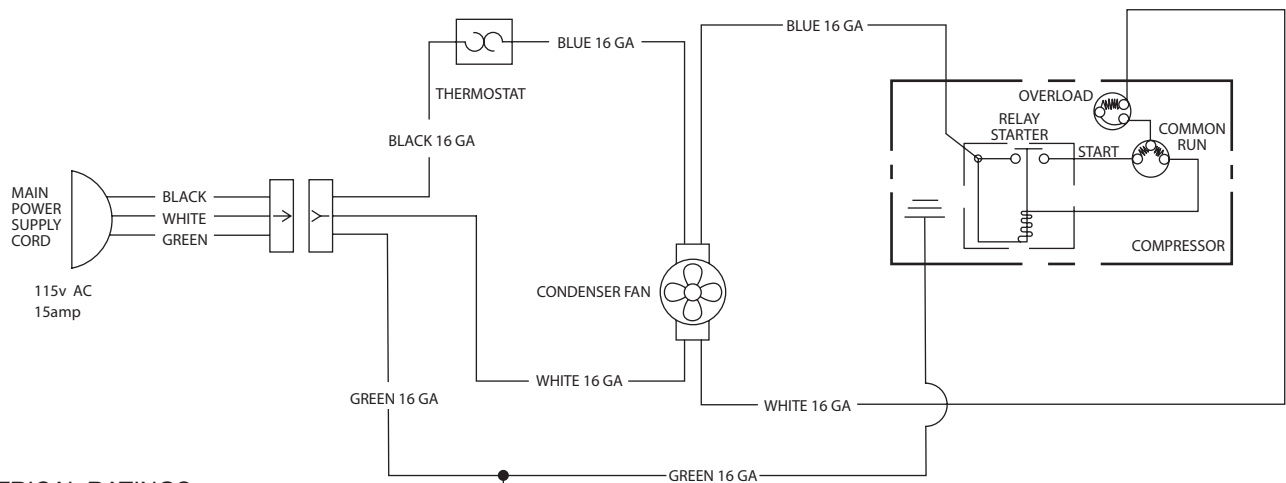

ELECTRICAL RATINGS

Compressor	115 VOLT	4.40 AMP
Condensing Unit Fan Motor	115 VOLT	.28 AMP
TOTAL AMPS		4.68

REFRIGERATION RATINGS

Refrigerant	R404A	6 oz.
Condensing Unit Fan Motor	Approx.	12 PSIG

REPLACEMENT PARTS



<u>PART NO.</u>	<u>OLD PART NO.</u>	<u>DESCRIPTION</u>	<u>LIST</u>
1. 04000105	GT-035012	Compressor, 1/5 HP, R404A refrigerant	\$460.00
2. 04000241		Start relay	19.00
3. 04000120	GT-032204	Start capacitor	18.00
4. 04000121	GT-031206	Overload	10.00
5. 06001445	GT-035107	Fan motor	35.00
6. 06001395	GT-032802	Fan blade	5.00
7. 07000133	GT-031513	Fan motor bracket	20.00
8. 04000100	GT-032608	Condenser coil	130.00
9. 06001385		Filter Dryer, 1/4" x 1/4"	20.00
10. 04000108	GT-036219	Door for single unit, models FRA-24, FRB-24, and DI-FR	114.00
11. 04000109	GT-036220	Door for double unit, models FRA-36, FRB-36, DI-FR36, and DI-FR36-DW	138.00
12. 04000110	GT-036253	Flip lid, double unit, models DI-FR36-FL and DI-FR36-DW-FL	162.00
13. 04000091	GT-031309	Single door gasket, 11-15/16" x 11-15/16"	18.00
04000092	GT-031310	Double door gasket, 21-15/16" x 11-15/16"	18.00
04000093	GT-031324	Flip lid gasket (two required), 11-7/8" x 11-1/32"	18.00
14. 04000184		Breaker strip, four pieces, single unit, models FRA-24, FRB-24, DI-FR, and DI-FR-DW (S/N 404099008X and greater)	25.00
04000118	GT-038506	Breaker strip, four pieces, single unit, models FRA-24, FRB-24, DI-FR, and DI-FR-DW (manufactured from 4/96 to 3/06)	25.00
04000185		Breaker strip, four pieces, double unit, models FRA-36, FRB-36, DI-FR36, DI-FR36-DW, DI-FR36-FL, DI-FR36-DW-FL (S/N 404099008X and greater)	30.00
04000119	GT-038507	Breaker strip, four pieces, double unit, models FRA-36, FRB-36, DI-FR36, DI-FR36-DW, DI-FR36-FL and DI-FR36-DW-FL (manufactured 4/96 to 3/06)	30.00
15. 04000104	GT-034617	Dipper well faucet	95.00
16. 04000112	GT-038426	6" Diameter stainless strainer	115.00
17. 04000265		Thermostat, Freeaer, 9530N1492, replacement	55.00
18. 04000126	GT-032102	Bracket, freezer lid cover, set of 2	25.00
04000124	GT-032509	Cap tube, (.036 x 96")	20.00
07000599		Replacement power cord assembly, includes (06001572 01000669 06001314)	40.00

220 VOLT 50 HZ REPLACEMENT PARTS

<u>PART NO.</u>	<u>DESCRIPTION</u>	<u>LIST</u>
04000106	Compressor, 1/5HP, 230/1/50, R404a	\$540.00
04000242	Start capacitor, 1/5 hp, 230/1/50, Tecumseh compressor AEA2380ZXC (04000106)	25.00
04000244	Overload Protector, 1/5 hp 230/1/50 Tecumseh compressor (04000106)	21.00
06001415	Relay 1/5 hp R22, 230/1/50V Tecumseh, model AEA2380ZXC (04000106)	19.00
06001448	Motor, evaporator fan, 220V	50.00

UNPARALLELED UNDERBAR DESIGN & ENGINEERING

Expect more



more flexibility

more features



**Glas
tender**®

Glastender has the most complete line of bar equipment and the ability to manufacture custom units, giving you virtually unlimited design flexibility. Each piece of equipment is engineered with features that enhance your efficiency, ease your maintenance, and prolong the life of your investment.

The flexibility you want. The features you need.

Glastender. Expect more.

GLASSWASHERS • COCKTAIL STATIONS • COOLERS • FROSTERS • BEER SYSTEMS