



FV48-SS(LR)



Project: _____	AIA# _____
Item #: _____ Qty: _____	SIS# _____
Model #: _____	

**Front Venting Coolers
One and Two Door
Self-Contained**

FV - (LR)

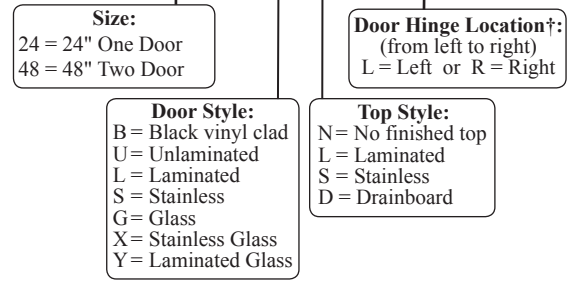

† The door on the FV24 may hinge either Left or Right. The hinges on the FV48 are only available as LR.

Standard Features

- Self-contained
- All stainless steel interior construction
- Foamed-in-place insulation
- Galvanized steel sub-top
- Black vinyl-clad steel exterior front and sides
- Six foot grounded cord and plug (exits at rear)
- Stainless steel die cast handle
- Automatic defrost timer
- Stainless steel evaporator housing with separate removable evaporator drain pan
- Automatic condensate evaporator
- 1/2" thick ABS plastic threshold scuff plate
- 180° swinging doors

Specifications

Electrical

- 120V, 1 phase, 60 Hz, 6.22 full load amps
- Dedicated 15 amp circuit is required
- Includes a 6 foot grounded cord and plug which exits the back of refrigeration compartment

Refrigeration

- 1/4 HP, R134a refrigerant

Operating Range

- 34° F to 40° F

Plumbing

- Automatic condensate evaporator. No drain connection required

Shelving

- One adjustable coated shelf and one bottom coated rack per door included

Legs

- 1-5/8" diameter
- Stainless steel bullet feet

Materials

- 22 gauge stainless steel parts include: interior floor, walls, ceiling, front of cabinet, and evaporator housing
- 22 gauge black vinyl-clad parts include: sides, standard door, and compressor compartment housing
- 22 gauge galvanized steel parts include: exterior sub-top and back
- 16 gauge stainless steel parts include: legs
- 16 gauge galvanized steel parts include: base
- 12 gauge stainless steel parts include: hinges, hinge brackets, and lock brackets

<p>Glastender, Inc. • 5400 N Michigan Rd • Saginaw, MI • 48604-9780 989.752.4275 • 800.748.0423 • Fax 989.752.4444 www.glastender.com</p>	Approval/Notes:
--	-----------------

Specifications subject to change without notice. For current specifications please visit our website.

Self-Contained Front Venting Coolers

Dimensional Information

FV24

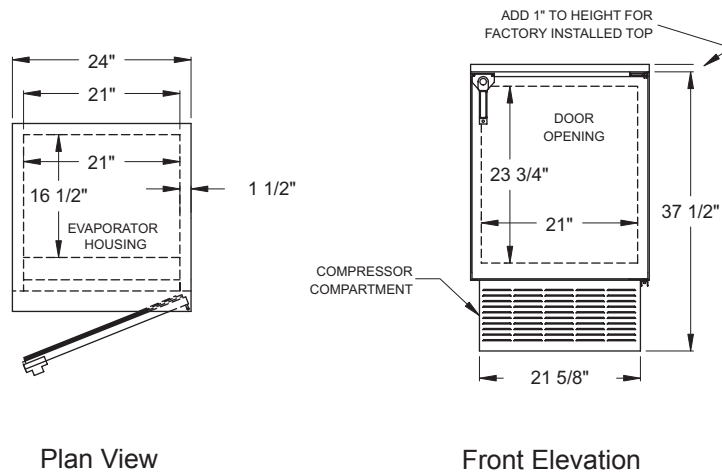

FV48

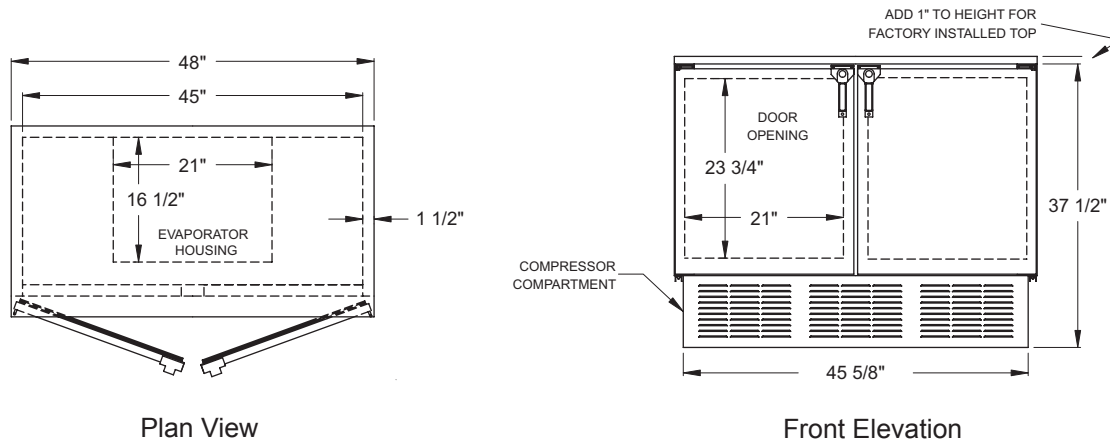

Side View All Models

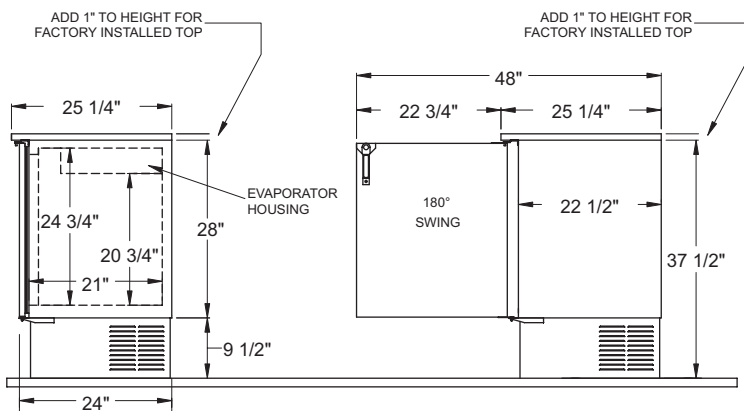

Model	Capacity: 12 oz. bottle	Refrigeration	Voltage	Amps
FV24	4.08 cases	1/4 H.P. / R134a	120v / 60 Hz / 1 phase	6.22 full load
FV48	9.33 cases	1/4 H.P. / R134a	120v / 60 Hz / 1 phase	6.22 full load