



BB48-L1-BSN(LR)



COMPONENT

NSF standard 7 listed for open food storage

Project: _____	AIA# _____
Item #: _____ Qty: _____	SIS# _____
Model #: _____	

Back Bar Coolers Two, Three and Four Door Remote

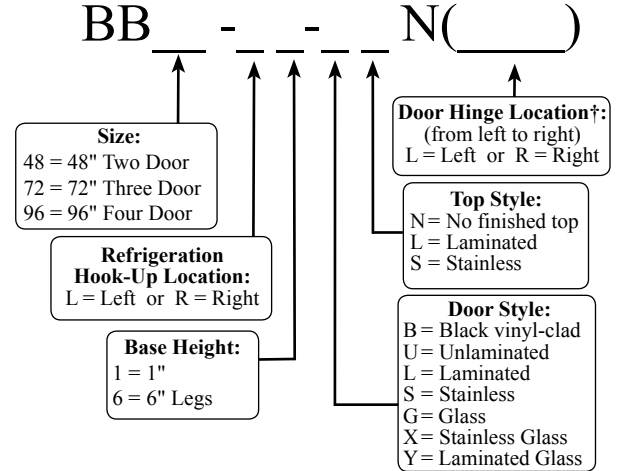

† Specify a hinge location for each door

Standard Features

- | | |
|--|---|
| <ul style="list-style-type: none"> Remote Unit All stainless steel interior construction with radius interior corners for easy cleaning CFC free foamed-in-place insulation Galvanized steel sub-top | <ul style="list-style-type: none"> Black vinyl-clad steel doors and exterior sides Stainless steel die cast handle Leg sockets recessed into base 1/2" thick ABS plastic threshold scuff plate 180° swinging doors |
|--|---|

Specifications

- Electrical*
- 120V, 1 phase, 60 Hz
 - Dedicated 15 amp circuit is required
 - 14 gauge wire connection is made inside the cooler next to evaporator housing - interior access is through one of the 3/4" side knock-out holes (electrician's choice)
- Refrigeration*
- R134a or R404a expansion valve & temperature control included. Specify type required when ordering.
 - Recommended condensing unit:
BB48 - 1/4 HP which has an approximate rating of 2,200 BTU/H at +20°F evaporator temperature
BB72 and BB96 - 1/3 HP which has an approximate rating of 3,064 BTU/H at +20°F evaporator temperature
 - All refrigeration hookups are made at the installation site
- Plumbing*
- A six foot length of 1/2" ID by 5/8" OD plastic tubing is provided to drain condensate. The tubing should exit through one of the 3/4" side knock-out holes (installer's choice). The maximum drainage is one ounce per hour - consult local codes for compliance - a floor drain may be required

- Shelving*
- Two adjustable coated shelves and one bottom coated rack per door included
- Legs*
- 1-5/8" diameter
 - Stainless steel bullet feet
- Materials*
- 22 gauge stainless steel parts include: interior floor, walls, ceiling, front of cabinet, and evaporator housing
 - 22 gauge black vinyl-clad parts include: sides and standard doors
 - 22 gauge galvanized steel parts include: exterior sub-top and back
 - 16 gauge stainless steel parts include: legs
 - 16 gauge galvanized steel parts include: base
 - 16 gauge zinc plated CR steel parts include: leg sockets
 - 12 gauge stainless steel parts include: hinges, hinge brackets, and lock brackets

<p>Glastender, Inc. • 5400 N Michigan Rd • Saginaw, MI • 48604-9780 989.752.4275 • 800.748.0423 • Fax 989.752.4444 www.glastender.com</p>	<p>Approval/Notes:</p>
<p>Specifications subject to change without notice. For current specifications please visit our website.</p>	

Remote Back Bar Coolers

Dimensional Information

BB48

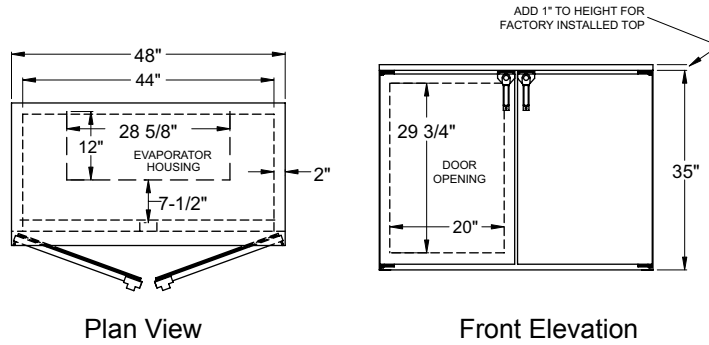

BB72

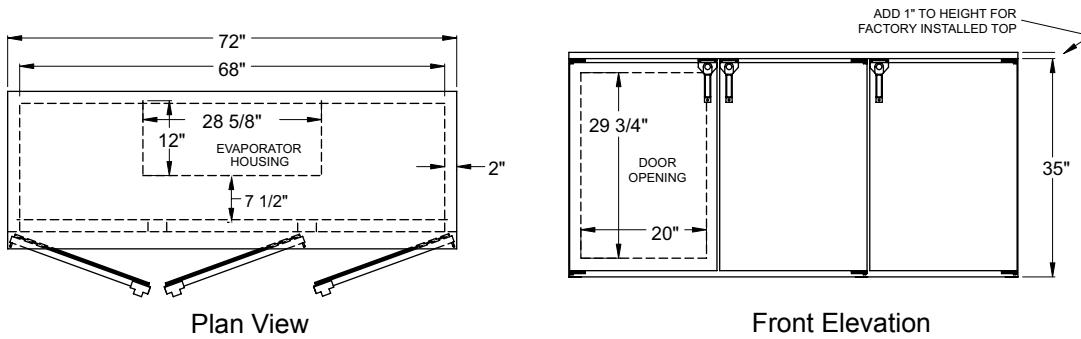

BB96

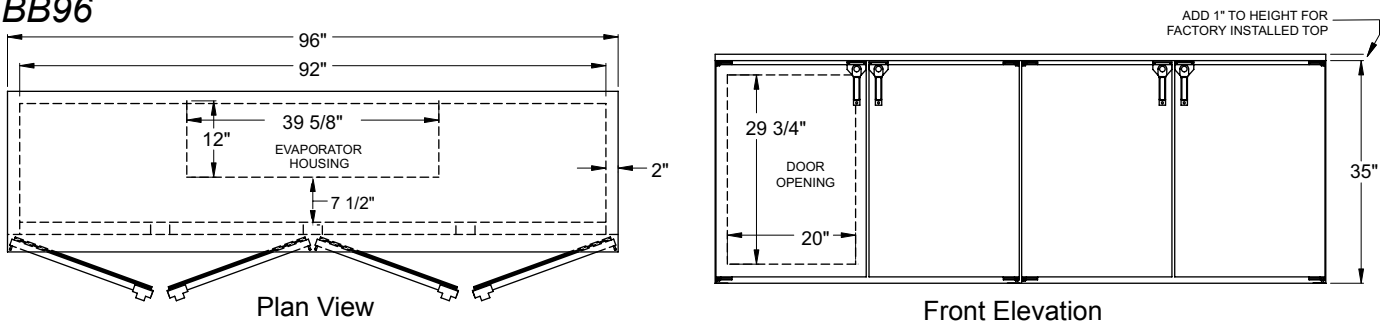

Side View All Models

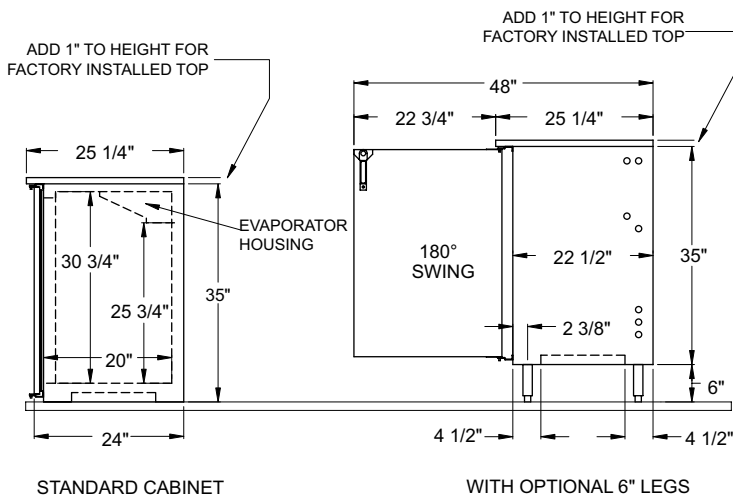

Model	Capacity: 12 oz. bottle / 1/2 barrels	Refrigeration	Voltage
BB48	13.6 cases / 2 half barrels	1/4 H.P. Recommended	120v / 60 Hz / 1 phase
BB72	21 cases / 4 half barrels	1/3 H.P. Recommended	120v / 60 Hz / 1 phase
BB96	28 cases / 5 half barrels	1/3 H.P. Recommended	120v / 60 Hz / 1 phase



5400 N Michigan Rd • Saginaw, MI • 48604-9780
 989.752.4275 • 800.748.0423 • Fax 989.752.4444
 www.glastender.com