

Project _____

Item # _____

Quantity _____



GLOBE FOOD EQUIPMENT COMPANY

Roller Grills

CPRG30 / CPRG50



Roller Grills

Globe.
The ULTIMATE in
Countertop Equipment

Model

- CPRG30 Roller Grill
- CPRG50 Roller Grill



Optional Accessories (Sold Separately)



- SIN10-CPRG30 Sneeze Guard for 30"
- SIN20-CPRG50 Sneeze Guard for 50"

Standard Features

- 11x chrome plated rollers
- Stainless steel construction
- Energy regulator control for front and back rollers
- Individual heating element within each roller
- Individual 360° roller rotation
- Removable, easy-to-clean, stainless steel catch tray
- Non-slip rubber feet
- 4-foot power cord
- Optional accessory - Polycarbonate sneeze guard cover

Product Capacity

- Model: CPRG30 - Capacity = 30
- Model: CPRG50 - Capacity = 50

Standard Accessories

- Stainless Steel Catch Tray

Applications

- Cooks hot dogs, bratwursts, and sausages

Standard Warranty

- Onsite Warranty:
One-year parts and labor or replacement

Approved By: _____

Date: _____



GLOBE FOOD EQUIPMENT COMPANY

www.globeslicers.com

2153 Dryden Rd.
Dayton, OH 45439
Phone: 937-299-5493
Phone: 800-347-5423
Fax: 937-299-4147



Roller Grills

CPRG30 / CPRG50

Specifications

Electrical:

CPRG30: 120V/1430W/11.9amps

CPRG50: 120V/1760W/14.7amps

Roller Grill Cooking Space:CPRG30: grill area 19.4" x 17"
(49.3 cm x 43.9 cm)CPRG50: grill area 31.2" x 17"
(79.2 cm x 43.9 cm)**Cord and Plug:** 4-foot flexible, three-wire cord with ground plug.**Thermostat:** The temperature is thermostatically controlled.**Consistent Heating:** Roller grill will maintain a consistent selected temperature to ensure product consistency.**Standard Equipment:** Standard equipment includes the roller grill and easy-to-remove catch tray.**Catch Tray:** Continuously collects grease and crumbs while cooking on the roller grill.**CPRG30 Dimensions:**Foot Print = 20.5" x 23.6"
(52.1 cm x 62.5 cm)
Overall Length = 20.5" (52.1 cm)
Overall Width = 23.6" (59.9 cm)
Overall Height = 13.1" (33.3 cm)**CPRG50 Dimensions:**Foot Print = 20.5" x 35.4"
(52.1 cm x 89.9 cm)
Overall Length = 20.5" (52.1 cm)
Overall Width = 35.4" (89.9 cm)
Overall Height = 13.1" (33.3 cm)**CPRG30 Shipping Information:**Net Weight: 40 lbs (18.1 kg)
Shipping Weight: 44 lbs (20.3 kg)**CPRG30 Shipping Dimensions:**26.8"W x 25.6"D x 17.4"H
(68 cm x 65 cm x 44 cm)**CPRG50 Shipping Information:**Net Weight: 54.01 lbs (24.5 kg)
Shipping Weight: 60.63 lbs (27.5 kg)**CPRG50 Shipping Dimensions:**38.6"W x 25.6"D x 17.4"H
(98 cm x 65 cm x 44 cm)**SIN10/CPRG30 Shipping Information:**Net Weight: 4.23 lbs (1.9 kg)
Shipping Weight: 7.1 lbs (3.3 kg)**SIN10/CPRG30 Shipping Dimensions:**21.5"W x 9.25"D x 24.6"H
(54.7 cm x 23.5 cm x 62.5 cm)**SIN20/CPRG50 Shipping Information:**Net Weight: 6.3 lbs (2.9 kg)
Shipping Weight: 10.27 lbs (4.7 kg)**SIN20/CPRG50 Shipping Dimensions:**21.5"W x 9.25"D x 36.4"H
(54.7 cm x 23.5 cm x 92.5 cm)

Cartons are reinforced for shipping. The weight and dimensions of this reinforced carton are included above and may vary from shipment to shipment.

CPRG30

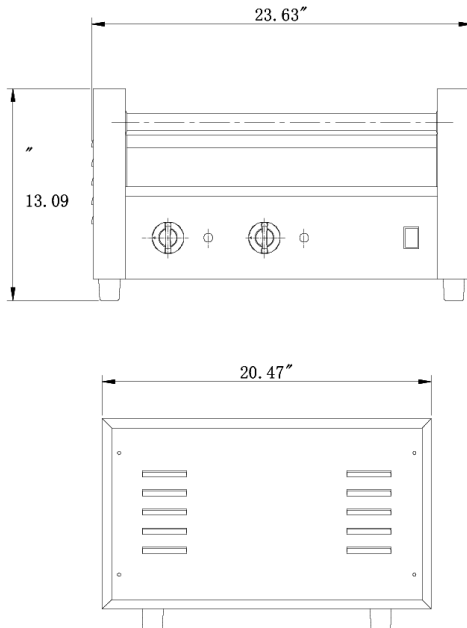

CPRG50

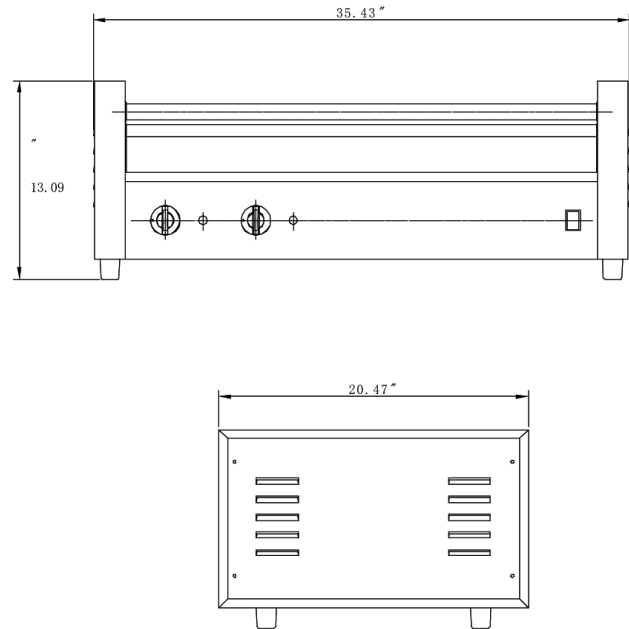
**GLOBE FOOD EQUIPMENT COMPANY**www.globeslicers.com2153 Dryden Rd.
Dayton, OH 45439
Phone: 937-299-5493
Phone: 800-347-5423
Fax: 937-299-4147

Printed in U.S.A. 08-2010

Specifications are subject to change without notice.