

☆ **IMPORTANT INFORMATION** ☆ **KEEP FOR OPERATOR** ☆ **IMPORTANT INFORMATION** ☆

OPERATOR MANUAL

Part Number 121085 Rev. B

OM-CC-E and C/2-E

DOMESTIC

**MODELS: CC10-E, (2)CC/0-E,
C/2-20-E, (2)C/2-20E
CONVECTION COMBO™
Combination Steamer-Oven**



CC10-E



(2)C/2-20EFC



THIS MANUAL MUST BE RETAINED FOR FUTURE REFERENCE. READ, UNDERSTAND AND FOLLOW THE INSTRUCTIONS AND WARNINGS CONTAINED IN THIS MANUAL.

**FOR YOUR SAFETY
DO NOT STORE OR USE GASOLINE OR OTHER FLAMMABLE VAPORS AND LIQUIDS IN THE VICINITY OF THIS OR ANY OTHER APPLIANCE.**

 **GROEN**®



IMPORTANT — READ FIRST — IMPORTANT

- WARNING:** THE UNIT MUST BE INSTALLED BY PERSONNEL QUALIFIED TO WORK WITH ELECTRICITY AND PLUMBING. IMPROPER INSTALLATION CAN CAUSE INJURY TO PERSONNEL AND/OR DAMAGE TO THE EQUIPMENT. THE UNIT MUST BE INSTALLED IN ACCORDANCE WITH APPLICABLE CODES.
- CAUTION:** SHIPPING STRAPS ARE UNDER TENSION AND CAN SNAP BACK WHEN CUT.
- CAUTION:** DO NOT INSTALL THE UNIT IN ANY WAY WHICH WILL BLOCK THE RIGHT SIDE VENTS, OR WITHIN 12 INCHES OF A HEAT SOURCE SUCH AS A BRAISING PAN, DEEP FRYER, CHAR BROILER OR KETTLE.
- CAUTION:** LEVEL THE UNIT FRONT TO BACK, OR PITCH IT SLIGHTLY TO THE REAR, TO AVOID DRAINAGE PROBLEMS.
- WARNING:** TO AVOID DAMAGE OR INJURY, FOLLOW THE WIRING DIAGRAM EXACTLY WHEN CONNECTING A UNIT.
- CAUTION:** DO NOT USE PLASTIC PIPE. DRAIN MUST BE RATED FOR BOILING WATER.
- WARNING:** DO NOT CONNECT THE DRAIN DIRECTLY TO A BUILDING DRAIN.
- WARNING:** BLOCKING THE DRAIN IS HAZARDOUS.
- IMPORTANT:** IMPROPER DRAIN CONNECTION WILL VOID WARRANTY.
- IMPORTANT:** DO NOT ALLOW ANY WATER TRAPS IN THE LINE. A TRAP CAN CAUSE PRESSURE TO BUILD UP INSIDE THE CAVITY DURING STEAMING, WHICH WILL MAKE THE DOOR GASKET LEAK.
- WARNING:** WHEN YOU OPEN THE DOOR, STAY AWAY FROM STEAM COMING OUT OF THE UNIT. STEAM CAN CAUSE BURNS.
- WARNING:** BEFORE CLEANING THE OUTSIDE OF THE OVEN, DISCONNECT THE ELECTRIC POWER SUPPLY. KEEP WATER AND CLEANING SOLUTIONS OUT OF CONTROLS AND ELECTRICAL COMPONENTS. NEVER HOSE OR STEAM CLEAN ANY PART OF THE UNIT.
- WARNING:** ALLOW COOKING CHAMBER TO COOL BEFORE CLEANING.
- WARNING:** CAREFULLY READ THE WARNINGS AND FOLLOW THE DIRECTIONS ON THE LABEL OF EACH CLEANING AGENT. USE SAFETY GLASSES AND RUBBER GLOVES AS RECOMMENDED BY DELIMING AGENT MANUFACTURER.
- WARNING:** DO NOT MIX DE-LIMING AGENTS (ACID) AND DE-GREASERS (ALKALI).
- WARNING:** DO NOT PUT HANDS OR TOOLS INTO THE COOKING CHAMBER UNTIL THE FAN HAS STOPPED TURNING.
- WARNING:** DO NOT OPERATE THE UNIT UNLESS THE REMOVABLE RIGHT SIDE PANEL HAS BEEN RETURNED TO ITS PROPER LOCATION.
- NOTICE:** DO NOT USE A CLEANING OR DE-LIMING AGENT THAT CONTAINS ANY SULFAMIC ACID OR ANY CHLORIDE, INCLUDING HYDROCHLORIC ACID. IF THE CHLORIDE CONTENT OF ANY PRODUCT IS UNCLEAR, CONSULT THE MANUFACTURER.
- NOTICE:** DO NOT USE ANY DE-GREASER THAT CONTAINS POTASSIUM HYDROXIDE OR SODIUM HYDROXIDE OR THAT IS ALKALINE.
- WARNING:** USE OF ANY REPLACEMENT PARTS OTHER THAN THOSE SUPPLIED BY GROEN OR THEIR AUTHORIZED DISTRIBUTOR VOIDS ALL WARRANTIES AND CAN RESULT IN BODILY INJURY TO THE OPERATOR AND DAMAGE THE EQUIPMENT. SERVICE BY OTHER THAN FACTORY-AUTHORIZED PERSONNEL WILL VOID ALL WARRANTIES.
- WARNING:** HIGH VOLTAGE EXISTS INSIDE CONTROL COMPARTMENTS. DISCONNECT FROM BRANCH BEFORE SERVICING. FAILURE TO DO SO CAN RESULT IN SERIOUS INJURY OR DEATH.

Table of Contents

OPERATOR WARNINGS 2

REFERENCES 3

EQUIPMENT DESCRIPTION 4

INSPECTION AND UNPACKING 5

WATER QUALITY AND TREATMENT 5

INSTALLATION AND START-UP INSTRUCTIONS 7

OPERATING INSTRUCTIONS 13

CLEANING 19

MAINTENANCE 21

TROUBLESHOOTING 21

DIAGRAMS AND SCHEMATICS 23

SERVICE LOG 27

References

UNDERWRITERS LABORATORIES, INC.
 333 Pfingsten Road
 Northbrook, Illinois 60062

NATIONAL FIRE PROTECTION
 ASSOCIATION
 60 Battery March Park
 Quincy, Massachusetts 02269

KLENZADE SALES CENTER
 ECOLAB, Inc.
 370 Wabasha
 St. Paul, Minnesota 55102
 800 328-3663 or 612 293-2233

NFPA/70 The National Electrical Code

NATIONAL SANITATION FOUNDATION
 3475 Plymouth Road
 Ann Arbor, Michigan 48106

OM-CC-E and C/2-E

Equipment Description

Your Groen Convection Combo™ has a stainless steel cooking chamber, an air heating compartment with electric heating elements and fan, a steam generator with electric heating elements, and a control compartment which houses other electrical components.

All major components of the Convection Combo™ are encased in a 16 gauge stainless steel cabinet. Glass fiber insulation, lines the cabinet at a thickness of 1½ to 2 inches (4 to 5 cm). A removable drip tray is located beneath the door.

The door is reversible so that it may open from the left or right side. Operator controls are located on the right side of the front panel.

Standard controls let you to operate the Convection Combo in any one of three cooking modes:

3. As a convection oven
4. As a self-contained, pressureless steamer
5. As a combination oven-steamer

CC10-E and C/2-20E models differ in cooking chamber size and capacity:

CC10-E: 4 steam table pans (12x20x2½"), or 7 half-size (13x18") US bake pans

C/2-20E: 10 steam table pans (12x20x2½"), or 9 full-size (18x26") US bake pans

The smaller Convection Combo™ is available as a table-top unit (the single CC10-E). These units are also supplied on a stainless steel stand as models CC10-EF and (2)CC10-EF. The larger Convection Combo™ is always supplied with a stand as the single C/2-20EF or the double-stacked (2)C/2-20EF.



CC-10EF



(2)CC10-EF



C/2-20EFC with optional pan rack

Inspection and Unpacking

Your Convection Combo™ will be completely assembled in a heavy shipping carton or wooden crate, and attached to a skid. On receipt, inspect the carton or crate carefully for exterior damage.

CAUTION
SHIPPING STRAPS ARE UNDER TENSION AND CAN SNAP BACK WHEN CUT.

Carefully cut the straps around the carton and detach the sides of the carton from the skid. Pull the carton up off the unit. Be careful to avoid personal injury or equipment damage from staples which might be left in the carton walls.

Write down the model number, serial number and installation date and keep this information for future reference. Space for these entries is provided at the top of the Service Log in the back of this manual.

CAUTION
THIS UNIT IS VERY HEAVY. YOU SHOULD GET HELP AS NEEDED TO LIFT THIS WEIGHT SAFELY.

When starting installation, lift the unit straight up off the skid. Check packing materials to make sure loose parts are not discarded with the material.

Water Quality and Treatment

It is essential to supply the steam generator/boiler with water that will not form scale. Even though the steam generator/boiler is engineered to minimize scale formation, scale development depends on the hardness of your water and the number of hours you operate the equipment each day.

But most water supplies contain minerals which form scale. It is this scale which could lead to an early component failure.

Your local water utility can tell you about the minerals in your water. The water going to the steam generator should have between 30 and 40 parts per million (ppm) total dissolved solids (TDS) and should have a pH (acidity rating) of 7.0 to 9.0. Please follow these simple precautions:

1. The best way to prevent scale is to use a Groen Puresteam™ Water Treatment System which has been specifically designed for Groen steamers and combination ovens. **Do not rely on unproven water treatments systems** sold for scale prevention and removal. **They are not specifically designed to work with Groen steamers and combination ovens.**
2. A well-maintained water treatment system and a regular cartridge replacement schedule is essential.
3. Using a Groen Water Treatment System will provide longer steam generator/boiler life, higher steam capacity, and reduce maintenance requirements.
4. If you notice a slowdown in steam production or an increase in deliming, have the combo checked for scale build-up. This could be an indication that the water treatment cartridges need replacing. Heavy scale reduces the unit's ability

to boil water, and can even cause component failure.

MINIMIZE SCALE PROBLEMS BY INSTALLING AND MAINTAINING A GROEN PURESTEAM™ WATER TREATMENT SYSTEM AND BY DELIMING THE STEAM GENERATOR/BOILER REGULARLY.

Groen Convection Combo™ ovens feature two separate water inlets — one for the steam generator/boiler (for treated water), the other for the spray condenser (untreated water). The second intake will reduce treatment requirements resulting in significant savings.

The dual water connections are on the rear of the unit.



Standard water connections for steam generator and drain spray condenser.

Installation and Start-Up

WARNING

THE UNIT MUST BE INSTALLED BY PERSONNEL WHO ARE QUALIFIED TO WORK WITH ELECTRICITY AND PLUMBING. IMPROPER INSTALLATION CAN CAUSE INJURY TO PERSONNEL AND/OR DAMAGE TO THE EQUIPMENT. THE UNIT MUST BE INSTALLED IN ACCORDANCE WITH APPLICABLE CODES.

CAUTION

DO NOT INSTALL THE UNIT WITH THE RIGHT SIDE VENTS BLOCKED OR WITHIN 12 INCHES OF A HEAT SOURCE (SUCH AS A BRAISING PAN, DEEP FRYER, CHAR BROILER OR KETTLE). DO NOT INSTALL TO THE LEFT OF ANY OPEN-FLAME EQUIPMENT.

DO NOT INSTALL WITHIN FOUR FEET OF A STEAM DRAIN.

TO AVOID DRAINAGE PROBLEMS, LEVEL THE UNIT FRONT TO BACK.

INSTALLATION MUST BE IN ACCORDANCE WITH ALL APPLICABLE CODES.

1. Mounting

Minimum rear clearance is 6" from back wall.

If you wish to install a Convection Combo™ on top of another, you should obtain a double stacked unit from the factory.

If the unit does not have a factory-installed stand, the installer must provide a table, stand or counter which is strong enough to support the unit. Use of casters is **not** recommended.

To avoid drainage problems, level the unit front to rear, or provide a slight pitch to the rear.

Bolt the unit to the table, stand or counter top, using the mounting holes in its base.

2. Electrical Supply Connections

b. Panel Removal

The right side panel must be removed to gain access to the wiring and control compartment. Remove the two screws at the bottom of the panel. Slide the panel toward the front of the unit, lift it and set it aside.

c. Supply Voltage

CC10-E and C/2-20E models must operate at the rated nameplate voltage, plus or minus 10%.

d. Terminal block

The terminal block for incoming power is located at the back of the control compartment.



WARNING

WHEN CONNECTING FOR SINGLE PHASE OPERATION, DO NOT CONNECT ANY WIRE TO LINE 3 (THE TERMINAL FARTHEST LEFT). THIS WILL CAUSE A SHORT CIRCUIT.

FOR CC10-E Models:

The ground terminal is found on the relay bracket below the terminal block. The Convection Combo™ must have a separate ground wire for safe operation. The ground wire must be at least 10 AWG (2.6 mm).

FOR C/2-20E Models:

The ground terminal is found below the terminal block. The Convection Combo™ must have a separate ground wire for safe operation. The ground wire must be at least 8 AWG (3.3 mm) for a 100 amp circuit breaker or 10 AWG (2.6 mm) for a 40 to 60 amp breaker.

e. Supply Wire

The type of wire needed is determined by finding the operating voltage and phase from the unit's back data plate and (on pre-1996 models) phase select connector. Refer to the "Electrical Supply Connection" label on the back of the unit for correct wire size and insulation temperature rating.

The specified wire must be used to comply with Underwriters Laboratories and National Electric Code requirements.

The knockout hole is sized for a **¾ inch (19 mm) conduit fitting in CC10-E models**, and **one inch (25.4 mm) for C/2-20E models**.

ELECTRICAL SUPPLY CONNECTION

(All wires copper only.)

Reference: National Electrical Code)

CC10-E MODELS			
Voltage	Phase	Wire Size	Insulation
208	1	6AWG (4.1mm)	75°C
208	1	8AWG (3.3mm)	90°C
208	3	8AWG (3.3mm)	75°C
240	1	8AWG (3.3mm)	75°C
240	3	8AWG (3.3mm)	75°C

C/2-20E MODELS		
Voltage	Size fo 75°C (THWN)	Size for 90°C (TWHN)
208	4 AWG (5.2 mm)	6 AWG (4.1 mm)
240	4 AWG (5.2 mm)	6 AWG (4.1 mm)
480	8 AWG (3.3 mm)	8 AWG (3.3 mm)

f. Branch Circuit Protection

Groen strongly recommends that each Convection Combo™ have its own branch circuit protection. **A double -stacked unit**

should have separate protection for the upper and lower steamer-ovens.

CURRENT DEMAND

CC10-E MODELS			
Voltage	Current		Power
	1 Phase	3 Ph., per Line	
208	44.7 A	27.5 A	9.3 KW
240	38.8 A	24.1 A	9.3 KW

C/2-20E MODELS		
Voltage	Current per line (Three Phase)	Power
208	65.4 A	21 KW
240	56.7 A	21 KW
480	28.3 A	21 KW

Each current-carrying conductor must have overcurrent protection. Refer to the label on the back of the unit for proper wire size and type. Watertight connections are required.

3. Water Supply Connection

A check valve (back siphonage device) must be installed in the incoming cold water lines in keeping with local plumbing codes. Water line pressure should be between 30 and 60 PSI (210 and 410 kPa). A pressure regulator is required above 60 PSI (410 kPa).

A ¾ inch (19 mm) NH (garden hose type) connector is required to connect the water supply to the water inlet valve. The water feed line diameter may not be less than ½ inch (13 mm). Use a washer (or if necessary, two washers) in the hose connection. Do not allow the connection to have any leak, no matter how small.

The CC10-E and C/2-20E are equipped with a dual water supply. Treated water must be supplied at a minimum rate of 1.5 gallons per minute. Untreated water must be supplied at a minimum rate of .34 gallons per minute for the CC10-E and .75 gallons per minute for the C/2-20E. Minimum water pressure for both the CC10-E and C/2-20E is 30 PSI. Double-stack units require doubled rates. To convert a steamer or combination oven to a single water connection, order single cold water adapter (part # 138473).

4. Drain Connection

a. CC10-E and C/2-20E Without Drain Tank (tabletop model)

A 1.5" hose for 10-E models or a 2" hose for 20-E models may be attached to the provided

OM-CC-E and C/2-E

drain elbow with a clamp. Do **not** use plastic pipe. The drain must withstand boiling water.

WARNING:
DO NOT CONNECT THE DRAIN DIRECTLY TO A BUILDING DRAIN.

There must be a free air gap between the end of the hose and the building drain. The free air gap should be as close as possible to the unit's drain. There must also be no other elbows or other restrictions between the unit drain and the two inch free air gap.

CAUTION
DO NOT USE PLASTIC PIPE. DRAIN MUST BE RATED FOR BOILING WATER.

WARNING
BLOCKING THE DRAIN IS HAZARDOUS.

Install the drain line with a constant downward pitch. This is especially important for double-stack units. The bottom unit is conceptually shown below.

IMPORTANT: Do not allow any water traps in the line. A trap can cause pressure to build up inside the cavity during steaming, which will make the door gasket leak.

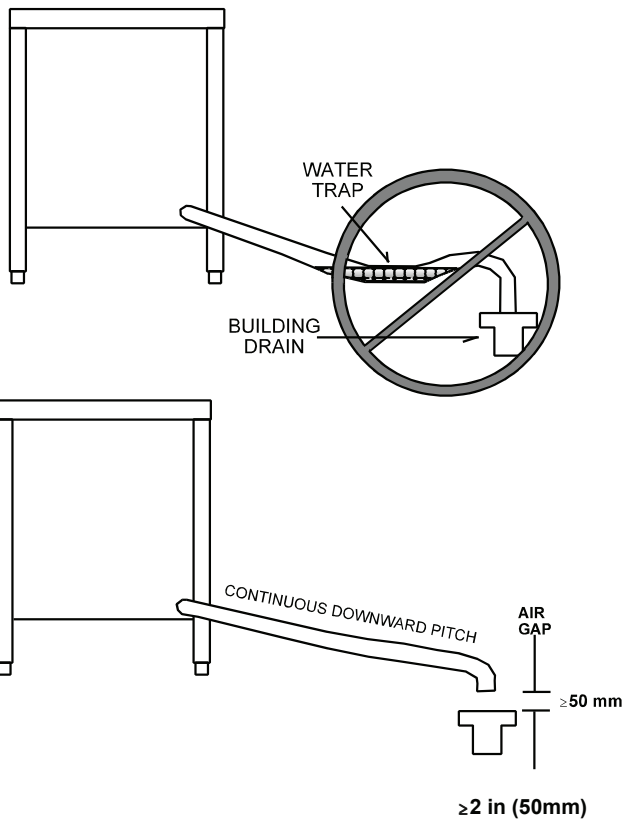

NOTE: Improper drain connection will void the warranty.

b. CC10-E and C/2-20E With Drain Tank

CC10-E Models:

A 1½ inch (4 cm) ID hose may be attached to the supplied drain elbow with a clamp.

C/2-20E Models:

A two inch (51 cm) ID hose may be attached to the supplied drain elbow with a clamp.

The hose may be connected directly to a building drain since the drain tank has an air vent, which eliminates the need for a free air gap at the building drain. Do not block the air vent in any way. Do not attach anything to the vent tube or reduce its size.

Do NOT use plastic pipe in the drain line, because the drain must withstand boiling water.



Drain Tank



Tabletop Model

Proper Drain Line Connections

All Current Table Mounted Models - With Drain Tank

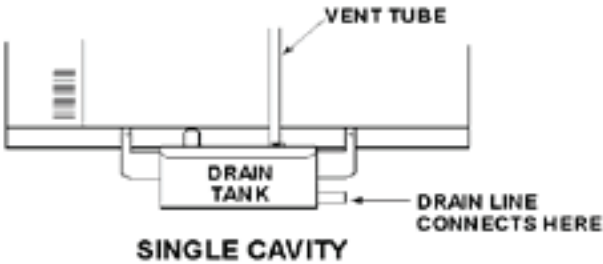

SINGLE CAVITY

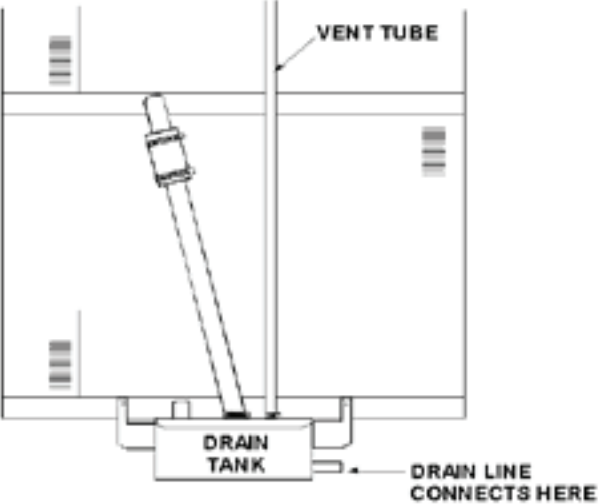

DOUBLE STACKED MODEL

Counter Top Models Without Drain Box

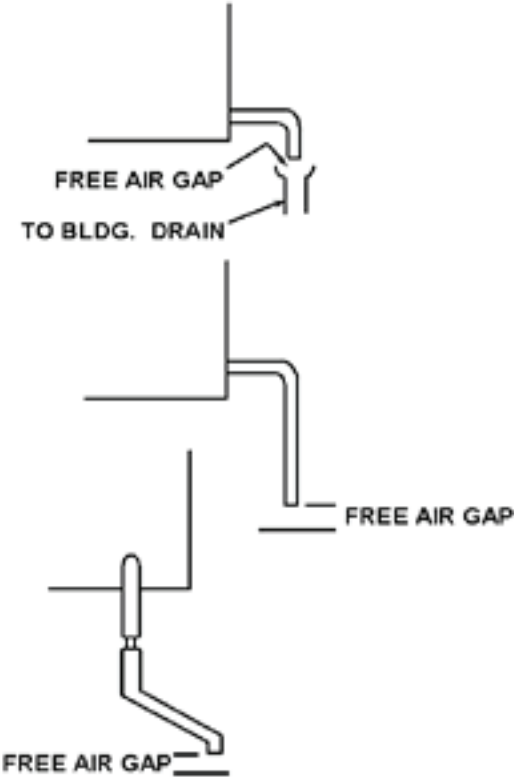

≥ 2 in (50 mm)

Initial Start-Up

WARNING
ANY POTENTIAL USER OF THE EQUIPMENT SHOULD BE TRAINED IN SAFE AND CORRECT OPERATING PROCEDURES.

After the Convection Combo™ has been installed, test it to ensure that it is operating correctly.

1. Remove all literature and packing materials from the interior and exterior of the unit.
2. Check that the cold water supply line is open and that none of the fittings are leaking.
3. Turn on electrical service to the unit.
4. **High Altitude Operation.** At altitudes above 5,000 feet (1524m), the unit will not operate in the Steamer or Combo Modes unless the altitude is set. The Convection Combo™ is delivered with the altitude set for 1000 feet as default. You can program the altitude as follows:
 - b. If the unit is on, turn it off by pressing the **ON** touch pad.
 - c. Press and hold the **STEAM** touch pad while turning the unit on by pressing the **ON** touch pad. The Time/Status display will show the letters AL and a number representing the altitude in thousands of feet. If the altitude has not been set for your unit, the display will be 1.
 - d. Enter an altitude value between 0 and 15, using the numbered touch pads. For example, if the unit will be operating at 7,000 feet, enter 7.
 - e. Press the **START** touch pad to accept the change.

Altitude Metric Conversion

Altitude		Setting
Feet	Meters	
1000	305	1
2000	610	2
3000	914	3
4000	1219	4
5000	1524	5
6000	1830	6
7000	2133	7
8000	2438	8
9000	2745	9
10000	3048	10
11000	3353	11

12000	3658	12
13000	3962	13
14000	4267	14
15000	4572	15

5. **For C/2-20E only: Check Fan Rotation —**

IMPORTANT! As seen from inside the oven cavity, the fan should be turning in a counterclockwise direction. If the fan is running backwards (clockwise), have a qualified electrician turn off the main power and switch any two incoming power leads on the distribution block. An incorrectly turning fan will eventually shut the oven down.

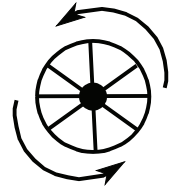

6. **Select Farenheit or Celsius Temperatures.**

The Convection Combo™ is delivered with the Farenheit scale as default. To change the current temperature scale, holding the 5 key in, press ON. The Time/Status display will either show dEG°F or dEG°C. Press the 5 key again to change from one to the other. Press START to accept the change.



7. **To Test Steamer Mode Operation,** turn on the unit. (For details of operating procedure, see the Operation section of this manual.) Clear time from the time display. Press the **STEAM** touch pad. (If the **HOT** light is on, see the Fast Cool instructions in the Operation section.)

The **WAIT** light will stay on while the steam generator fills with and heats the water. The **WAIT** light should turn off within three minutes, and the **READY** light should come on. This indicates that the water is at its standby temperature. The timer only controls operations in the Steamer Mode. Enter a time and press **START**. (“Time” is set in minutes and hours only. Seconds are not displayed). See example.

Examples: 2 minutes = 00:02
(Just press 2).
1 hour and 30 minutes = 01:30
(Press 1, 3, and 0, or press 9,0
the timer will change to 1:30)

The colon [:] between the numbers on the time display will blink and the generator will begin to produce steam. The time will not count down unless the **READY** light is lit.

NOTE: You cannot change modes if the timer is running.

8. **To Test Combo Mode Operation**, turn on the power and clear any time from the timer display. Press the **COMBO** touch pad. Set the **COOK** temperature to 300°F (150°C). The **WAIT** light will come on. It will remain on while (1) the steam generator fills with water and heats it to its standby temperature and (2) the air heater raises the air temperature to 300°F. Both actions should be completed in about five minutes, starting with a cold unit. When the set temperature is attained, the **WAIT** light will go off, and the **READY** light will come on.

NOTE: The timer does not control the oven in either the Combo or Oven Modes.

9. **To Test Oven Mode Operation**, turn on the power and clear the Time/Status display. Press the **OVEN** touch pad. Set the cook temperature to 350°F (175°C). The **WAIT** light will come on. Within six minutes from a cold start, the **WAIT** light should go out and the **READY** light should come on. When that happens, turn the **COOK** temperature setting down to 320°F (160°C). The **HOT** light will come on. The heat-up times provided above may vary slightly as a result of voltage or water pressure differences.
10. To shut down the unit, switch off the power.
11. If your Convection Combo™ behaves as described, the unit is functioning correctly, and is ready for use.

Standard Operating Controls

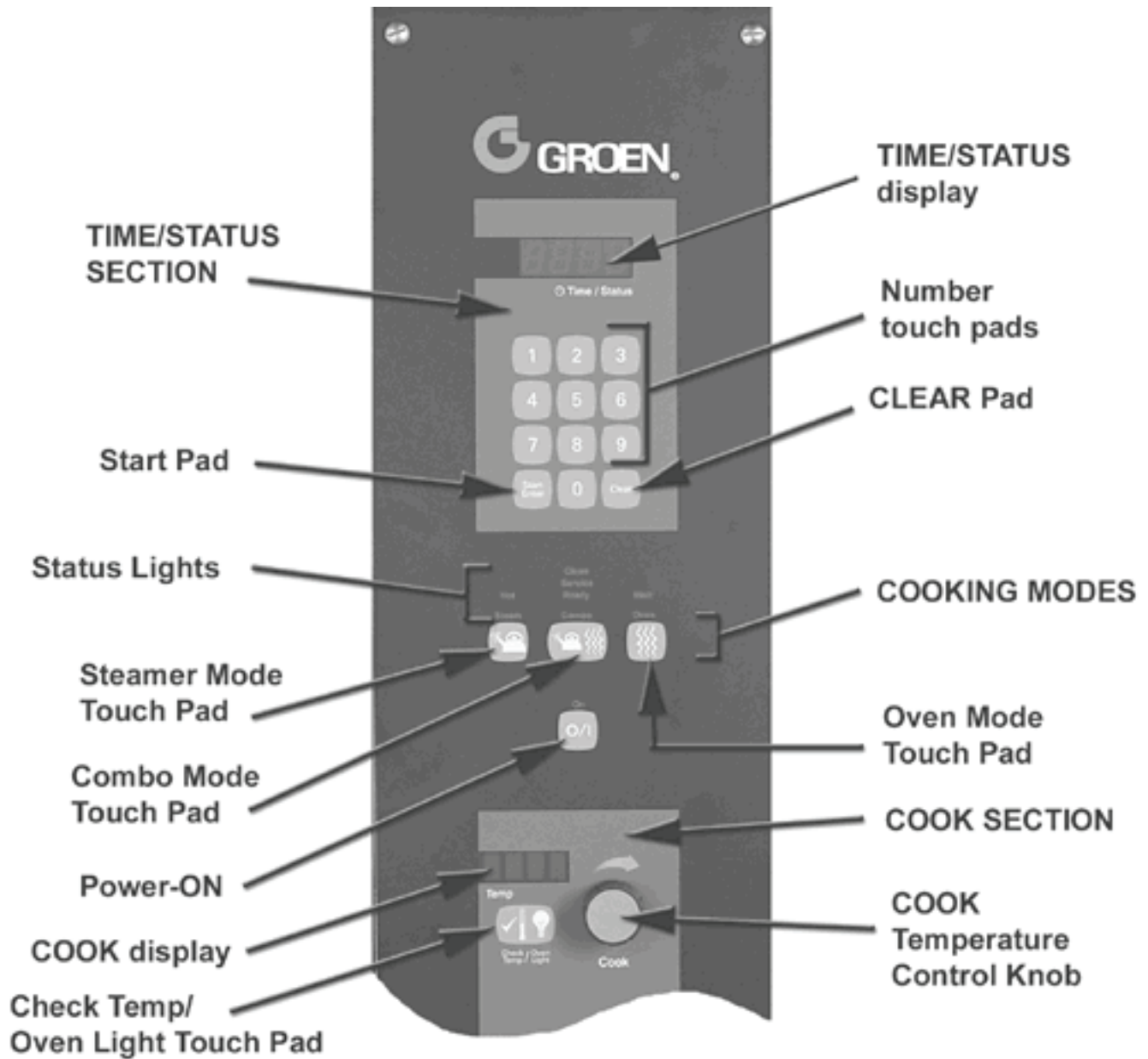

Operation

WARNING
ANY POTENTIAL USER OF THE EQUIPMENT SHOULD BE TRAINED IN SAFE AND CORRECT OPERATING PROCEDURES.

A. Controls and Indicators

Operator controls are on the right front side of the unit. Their use is described below:

1. Time Section

In Oven and Combo Modes, the timer functions only as a “cooking time minute minder” and does not turn the unit on or off. In the Steamer Mode, however, it controls the steaming function.

- a. **Time/Status Display** — Shows operating time remaining in the Steamer, Oven or Combo Mode. The timer counts **down**. If the unit is equipped with, and operating in the optional Hold Mode, the timer will count **up** alternating with the word “Hold,” and will show the total accumulated time that the product has been holding. The display shows operating time in “hours:minutes” format. For example, entering 9 and 0 will result in a display of 01:30.
- b. **Number touch pads** — used to enter time values.
- c. **CLEAR** — Pressing this touch pad once stops the beeper and resets the timer to the time that was last set. Pressing twice clears it to 00:00. At the end of a cooking period, opening the door is the same as pressing **CLEAR** once.
- d. **START** — Press this touch pad to start the timer. If the unit is in Steamer Mode, it will also cause steaming to begin.

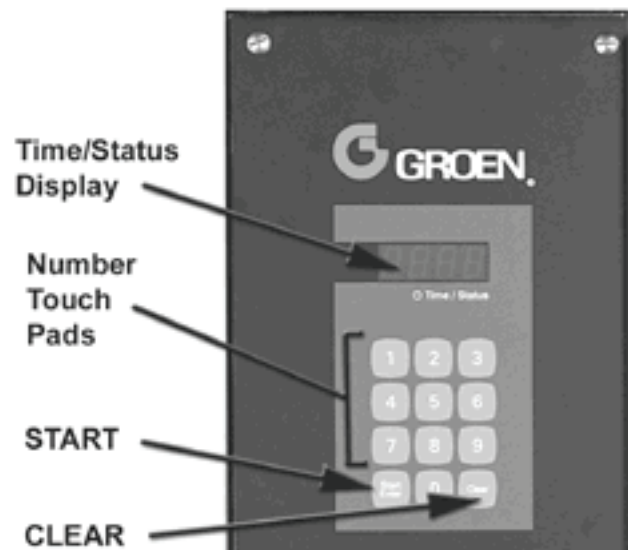

2. Status Lights

- a. **HOT** — Indicates cooking chamber temperature is more than 15°F (8°C) over the set temperature. (See Paragraph 5 in this section)
- b. **SERVICE** — Indicates that there is a problem which **might** require a service call. If there is such a problem, the beeper will sound and the **SERVICE** light will be on when you switch on the power. The unit may continue to operate, depending on the type of problem. Refer to the Troubleshooting section to determine the nature of the problem.
- c. **WAIT** — Indicates the unit is either heating or cooling toward the set temperature. The **HOT** and **WAIT** lights will both be on if the chamber is more than 15°F (8°C) above the set point.
- d. **READY** — Indicates the unit is ready for use.
- e. **CLEAN** — Indicates the unit needs cleaning. The unit will temporarily operate if this light is flashing.

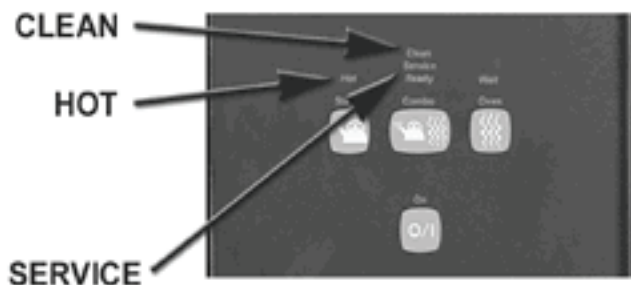

OM-CC-E and C/2-E

3. Cooking Mode Selection

- a. **STEAM** — Selects steamer operation only.
- b. **COMBO** — Selects superheated steam and convection oven operation.
- c. **OVEN** — Selects convection oven operation only.

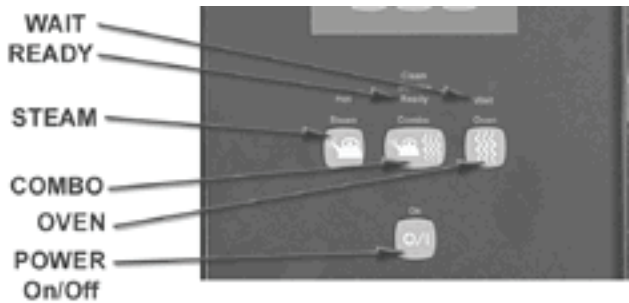

4. Power

The **ON** touch pad turns the unit on or off. When power is on, the **ON** light just above the touch pad is lit. Use of this pad does not reset the controls. The unit will always come on in the same mode it was in when shut down.

5. Temperature (TEMP) Section

- a. The Cook Display Window shows the selected temperature in either Oven or Combo Mode. It is blank in the Steamer Mode or when the optional Hold Mode is operational.
- b. Turning the Temperature Control Knob selects the cooking temperatures in 5°F increments. The control ranges are:

Oven Mode 200-575°F (95-300°C)
Combo Mode 220-575°F (105-300°C)

NOTE: Maximum temperature is limited to 500°F when either the optional probe or optional hold mode is in use.

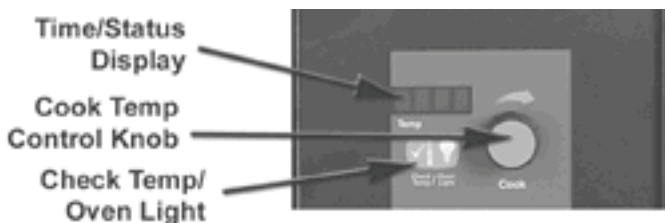

6. Optional Features

If the following features are included, please refer to the control panel guide which was provided with the unit:

Cook Only Guide: P/N 121084
Programmable: P/N 121042
Probe & Hold: P/N 121072

B. Operating Instructions

1. Steamer Mode

- a. If the unit is off, switch on the electric power by pressing the ON touch pad. (If the **SERVICE** light comes on when you turn on the power, see the Troubleshooting section).
- b. If the power is already on, and there is a number in the time display window, press the **CLEAR** touch pad one or more times to reset the time to zero.

NOTE: You cannot change operating modes while the timer is running

- c. The unit will power up in the mode of operation in which it was last used. Because of this, the indicator light for that mode will be lit. If the unit is not already in the Steamer Mode, press the **STEAM** touch pad. The **STEAM** light will come on and the Cook display will go blank.
- d. If the unit was recently used in Oven or Combo Mode, the **HOT** light may come on, indicating that the cooking chamber is too hot for use as a steamer. The unit can be cooled quickly to the steaming temperature range by leaving the door open or following the Fast Cool procedure described near the end of this section (Paragraph 4). With the door open the generator can fill and heat the water to 200°F, but it cannot produce steam.



WARNING
WHEN YOU OPEN THE DOOR STAY AWAY FROM ANY STEAM COMING OUT OF THE UNIT. STEAM CAN CAUSE BURNS.

- e. The **WAIT** light will be on until the water reaches 200°F (93°C). It will then turn off and the **READY** light will come on. You are now ready to steam foods in your Convection Combo™.
- f. Load the food into pans in an even, uniform layer.

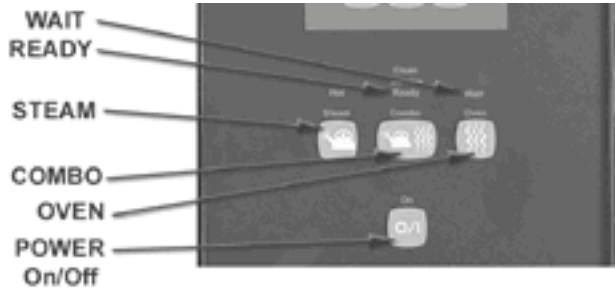

- g. Carefully open the door and slide the pan or pans onto the pan racks in the cooking chamber. If you are only using one pan, place it in the middle position. Close the door.
- h. Press the numbered touch pads to set the cooking time. The time will appear in the Time/Status display. If you enter the wrong number, press the **CLEAR** touch pad to erase the time from the display, and enter the time again.
- i. When the correct cooking time has been entered, press the **START** pad. The colon in the Time/Status display will blink and the time will count down the cooking time. (The unit must be **READY** before the timer can count down.)
- j. If you open the door during the cooking process, steaming and the timer will stop (but will not reset). When you close the door, steaming and timing will continue.



WARNING
WHEN YOU OPEN THE DOOR STAY AWAY FROM ANY STEAM COMING OUT OF THE UNIT. STEAM CAN CAUSE BURNS.

- k. When the timer reaches zero, it stops steam generation and sounds a beeper alarm. Water in the steam generator stays at its standby temperature (200°F - 93°C).

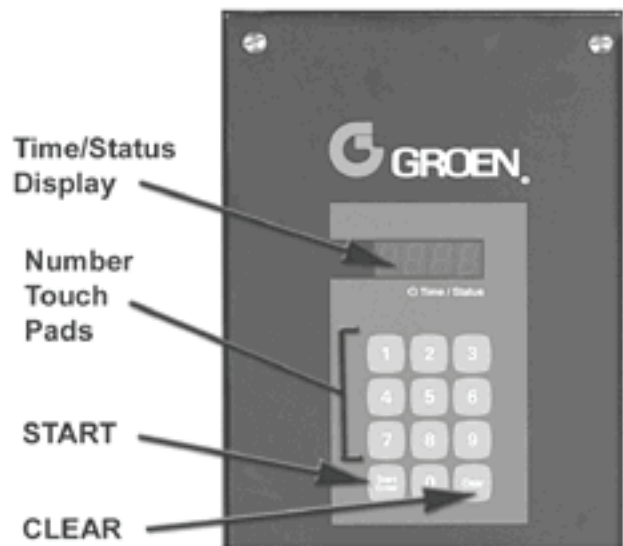

- l. Carefully open the door. If the food is cooked, remove the pans using hot pads or oven mitts to protect your hands from the hot pans.
- m. After the Time/Status display has counted down to zero, opening the door or pressing **CLEAR once** will reset the Time/Status display to the time that was last used. Pressing **START** will repeat the cook cycle. If the same cooking time will be used repeatedly, you only need to press the number keys when you first set that time.

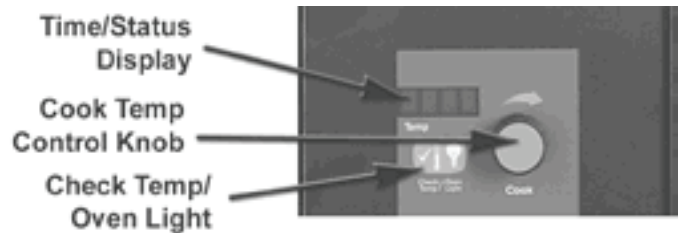

- n. After the Time/Status display has counted down to zero you can reset the time to zero by either (1) opening the door **and** pressing **CLEAR** or pressing **CLEAR** twice. A new cooking time may then be set by using the number keys.

OM-CC-E and C/2-E

2. Oven Mode

- a. To use the Convection Combo™ as a convection oven, first switch on the electric power by pushing the **ON** touch pad. (If the **SERVICE** light comes on when you turn on the power, see the Troubleshooting section). If the door is closed and the cooking temperature is above 250°F (120°C) the fan will begin to operate.
- b. If the power is already on, and there is a number in the Time/Status display window, press the **CLEAR** touch pad one or more times to reset the time to zero.

NOTE: You cannot change operating modes while the timer is running

- c. The unit will power up in the mode of operation in which it was last used. Because of this, the indicator light for that mode will be lit. If the unit is not already in the Oven Mode, press the **OVEN** touch pad. The **OVEN** light will come on and the oven fan will operate.
- d. Use the Temperature Control Knob to set the desired cooking temperature between 200° and 575° F (93° to 300° C). **NOTE:** Temperature is limited to 500°F if the optional probe or optional hold mode is in use. The temperature will appear in the Cook display. Unless the cooking chamber is already at or above the selected temperature, the unit will begin heating and the **WAIT** light will come on.

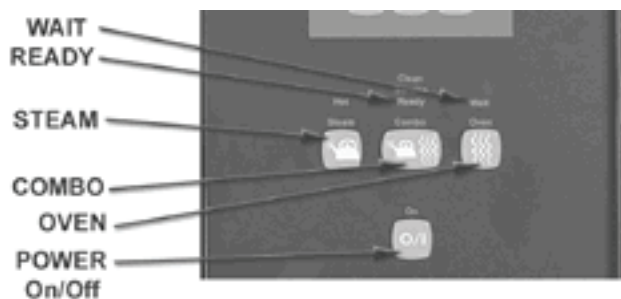

- e. If the unit was recently used at a temperature more than 15°F (8°C) higher than the temperature selected, the **HOT** and **WAIT** lights will turn on. The unit can be cooled quickly to the desired cooking temperature by leaving the door open or following the Fast Cool procedure described near the end of this section (Paragraph 4).
- f. The **READY** light will indicate when the oven is at the desired temperature.

- g. Load the food into the pan or pans in a uniform layer.
- h. The Convection Combo™ will operate in Oven Mode with the timer either on or off. If you want to time the cooking, press the numbered pads in the Time/Status portion of the control panel to set the cooking time. The time will appear in the Time/Status display. If you enter the wrong number, press the **CLEAR** touch pad to erase the time from the display, and enter the time again. **Remember that the timer does not control the unit in the Oven Mode.**
- i. Open the door and slide the pan or pans onto the pan racks in the cooking chamber. If you are only using one pan, place it in the middle position. Close the door.
- j. If the correct time has been set on the timer, press the **START** pad. The colon [:] between the numbers in the Time/Status display will blink and the time will count down the cooking time. When the timer has counted down to zero, it will sound a beeper. This sound will continue until the door is opened or the **CLEAR** pad is pressed.

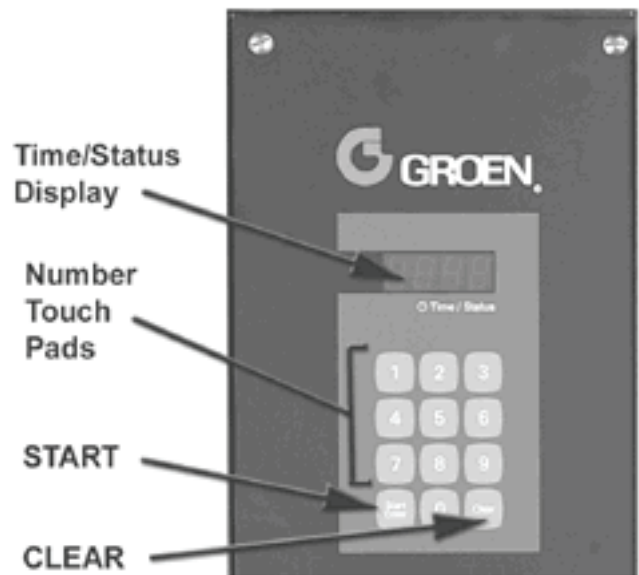

- k. To stop cooking, take the pans out of the oven using hot pads or oven mitts to protect your hands from the hot pans. The unit will continue heating to keep the chamber at the set temperature until the temperature control is reset, or the power is shut off.



WARNING
PANS AND INTERNAL PARTS OF THE OVEN
WILL BE VERY HOT. AVOID CONTACT WITH
HOT SURFACES.

- i. Opening the door during operation shuts off power to the heaters and fan and stops the timer, but it has no other affect on the controls. When the door is closed, operation continues. Note that cooking time will be extended by the period the door was open.

3. Combo Mode

- a. If the unit is off, switch on the electric power by pressing the ON touch pad. (If the **SERVICE** light comes on when you turn on the power, see the Troubleshooting section). If the door is closed and the cooking temperature is above 200°F (93°C) the fan will begin to operate.
- b. If the power is already on, and there is a number in the Time/Status display, press the **CLEAR** touch pad one or more times to reset the time to zero.

NOTE: You cannot change operating modes while the timer is running

- c. The unit will power up in the mode of operation in which it was last used. Because of this, the indicator light for that mode will be lit. If the unit is not already in the Combo Mode, press the **COMBO** touch pad. The **COMBO** light will come on and if the steam generator is not already full, water will flow into it and begin heating.
- d. Use the Temperature Control Knob to set the desired oven temperature between 220 and 575°F (105 to 300°C). The temperature will appear in the Cook display.
- e. If the unit was recently used at a temperature more than 15°F (-8°C) higher than the temperature selected, the **HOT** and **WAIT** lights will turn on. The unit can be cooled quickly by leaving the door open or following the Fast Cool procedure described near the end of this section (Paragraph 4).



WARNING
WHEN YOU OPEN THE DOOR STAY AWAY
FROM ANY STEAM COMING OUT OF THE UNIT.
STEAM CAN CAUSE BURNS.

- f. The **WAIT** light will be on until the water in the steam generator reaches the boiling point and the air in the cooking chamber reaches the set temperature. It will then turn off and the **READY** light will come on indicating that the oven is at the desired temperature.
- g. The unit will operate in Combo Mode with the timer either on or off. If you want to time the cooking, press the numbered pads in the Time/Status portion of the control panel to set the cooking time. The time will appear in the Time/Status display. If you enter the wrong number, press the **CLEAR** touch pad to erase the time from the display, and enter the time again. **The timer does not control the unit in Combo Mode.**
- h. Load the food into the pan or pans in a uniform layer.



WARNING
WHEN YOU OPEN THE DOOR STAY AWAY
FROM ANY STEAM COMING OUT OF THE UNIT.
STEAM CAN CAUSE BURNS.

- i. Open the door and slide the pan or pans onto the pan racks in the cooking chamber. If you are only using one pan, place it in the middle position. Close the door.
- j. If the timer has been set, press the **START** pad. The colon [:] between the numbers in the Time/Status display will blink and the time will count down the cooking time. When the timer has counted down to zero, it will sound a beeper. This beeping will continue until the door is opened or the **CLEAR** pad is pressed.

OM-CC-E and C/2-E

- k. To stop cooking, take the pans out of the oven using hot pads or oven mitts to protect your hands from the hot pans. The unit will continue steaming and heating the oven at the set temperature until the temperature control is reset, or the power is shut off.

4. Fast Cool

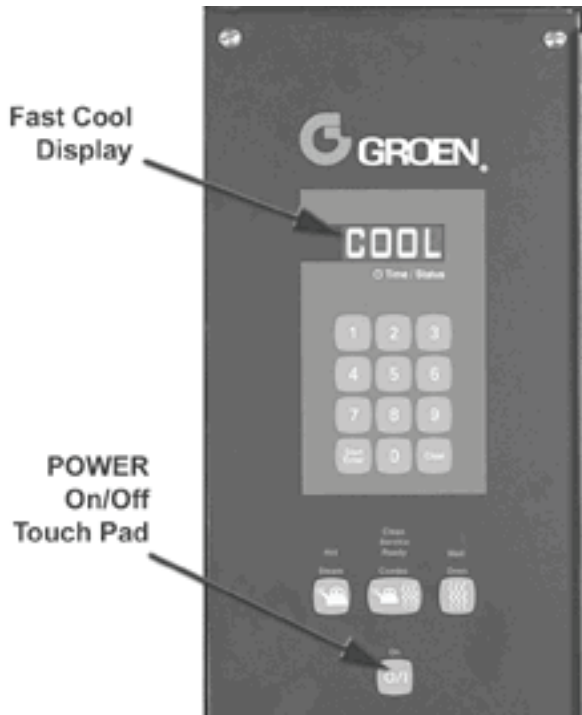

- a. When the **HOT** indicator is lit and the timer is cleared, the unit can be cooled quickly by opening the door and pressing **START**. The fan will operate, and the Time/Status display will show the word "**COOL**." This is the only time the fan operates **with the door open**.



WARNING
DO NOT PUT HANDS OR OTHER OBJECTS INTO THE COOKING CHAMBER DURING THE FAST COOL OPERATION. THE ROTATING FAN CAN BE HAZARDOUS.

- b. To stop the Fast Cool operation, press any touch pad or close the door.

5. Shutting Down

Switch off the power by pressing the **ON** touch pad.

Leave the door at least partially open, if local sanitation regulations permit.

Cleaning

To keep your Convection Combo™ in proper operating condition and to make the cleaning process easier, cleaning should be a daily activity.

A. Suggested Tools and Cleaners

1. Mild detergent
2. Stainless steel exterior cleaner such as Zepper®
3. Steam generator de-liming agent, such as **Groen Delimer Descaler**. A liquid de-liming agent will be easier to use than crystals or powders. See the warning about chlorides below.
4. Cloth or sponge
5. Plastic wool or a brush with soft bristles
6. Spray bottle
7. Measuring cup
8. Nylon pad
9. Towels
10. Plastic disposable gloves



B. PROCEDURE

1. Exterior Cleaning

- a. Prepare a warm solution of the mild detergent as instructed by the supplier. Wet a cloth with this solution and wring it out. Use the moist cloth to clean the outside of the unit. Do not allow freely running liquid to touch the controls, the control panel, any electrical part, or any open louver.
- b. To remove material which may be stuck to the unit, use plastic wool, a fiber brush, or a plastic or rubber scraper with a detergent solution.
- c. Stainless steel surfaces may be polished with a recognized stainless steel cleaner such as Zepper®.
- d. For glass surfaces, use a mild detergent without abrasives or a high quality glass/surface spray cleaner with a clean cloth or sponge. Do not spray hot glass with water or chemicals. This could cause the glass to break from thermal shock.
- e. Use mild soap without abrasives and warm water to clean the door gasket. **DO NOT** use caustic oven cleaners on the door gasket, as this will damage it.

PRECAUTIONS

WARNING

DISCONNECT THE POWER SUPPLY BEFORE CLEANING THE OUTSIDE OF THE UNIT.

KEEP WATER AND CLEANING SOLUTIONS OUT OF CONTROLS AND ELECTRICAL COMPONENTS. NEVER HOSE OR STEAM CLEAN ANY PART OF THE UNIT.

DON'T MIX DE-LIMING AGENTS (ACID) WITH DE-GREASERS (ALKALI) ANYWHERE IN THE UNIT

AVOID CONTACT WITH ANY CLEANERS, DE-LIMING AGENT OR DE-GREASER AS RECOMMENDED BY THE SUPPLIER. MANY ARE HARMFUL. READ THE WARNINGS AND FOLLOW THE DIRECTIONS!

EVEN WHEN THE UNIT HAS BEEN SHUT OFF, DON'T PUT HANDS OR TOOLS INTO THE COOKING CHAMBER UNTIL THE FAN HAS STOPPED TURNING.

DON'T USE ANY CLEANING OR DE-LIMING AGENT THAT CONTAINS ANY SULFAMIC AGENT OR ANY CHLORIDE, INCLUDING HYDROCHLORIC ACID (HCl). TO CHECK FOR CHLORIDE CONTENT SEE ANY MATERIAL SAFETY DATA SHEETS PROVIDED BY THE CLEANING AGENT MANUFACTURER.

UNIT MAY BE HOT. TAKE PRECAUTIONS TO PREVENT CONTACT WITH HOT SURFACES.

IMPORTANT

DO NOT USE ANY METAL MATERIAL (SUCH AS METAL SPONGES) OR METAL IMPLEMENTS (SUCH AS A SPOON, SCRAPER OR WIRE BRUSH) THAT MIGHT SCRATCH THE SURFACE. SCRATCHES MAKE THE SURFACE HARD TO CLEAN AND PROVIDE PLACES FOR BACTERIA TO GROW. DO NOT USE STEEL WOOL, WHICH MAY LEAVE PARTICLES IMBEDDED IN THE SURFACE WHICH COULD EVENTUALLY CAUSE CORROSION AND PITTING.

OM-CC-E and C/2-E

WARNING
DO NOT SPRAY OR CLEAN THE DOOR WHILE HOT. GLASS BREAKAGE MAY OCCUR IF THE DOOR IS RAPIDLY COOLED WITH WATER.

- f. Always check the jumper cord between the oven front panel and the door after cleaning. Make sure that it is properly positioned as shown to prevent damage.



2. Interior CLEANING STEPS (Two Stage Process)

For the (2)CC-10E and (2)C/2-20E double-stacked units, the cleaning processes must be performed on each cavity.

To exit the Clean Cycle at any time, press and hold the **CLEAR** touch pad. **Be sure to wash out all chemical residues thoroughly before using the unit.**



WARNING
UNIT MAY BE HOT. DO NOT TOUCH HOT SURFACES.

DO NOT PUT HANDS OR OTHER OBJECTS INTO COOKING CHAMBER WHILE CONVECTION COMBO™ IS OPERATING. THE ROTATING FAN CAN BE HAZARDOUS.

I. Degreasing

1. Take the oven out of any mode in which it may have been operating. Enter **99** into the timer. **C1** will appear in the Time/Status display. If the **HOT** light is on, follow “Fast Cool” instructions on page 17.
2. Remove oven racks, right side panel of cooking cavity and steam generator cover.
3. Thoroughly coat cooking cavity and both sides of right side panel with oven degreaser.

If you see grease deposits in the steam generator, add ¼ cup degreaser to generator or lightly coat generator area and elements with spray degreaser.

Put generator cover and right side panel back into position.

4. Close door and press **START**. The Time/Status display reads **CL:50**, colon flashes and oven counts down to **CL:26**.

II. Deliming

5. At **CL:26** the Time/Status display reads **C2** and the buzzer sounds.



WARNING
THE UNIT WILL BE HOT ENOUGH TO CAUSE A BURN. DO NOT TOUCH ANY HOT SURFACE.

Open door and remove the right side panel and steam generator cover. Thoroughly wipe down the cooking cavity with clean water. If any baked-on residue is still present, use a nylon scrub pad and rinse again.

6. Pour one pint (480 ml) for CC10-E models and two pints (960 ml) for C/2-20E models of delimer/descaler into the steam generator channel. Put the generator cover and right side panel back in place.
7. Close door. The Time/Status display reads **CL:26** and the unit completes deliming, counting down to **CL:00**.



WARNING
UNIT MAY BE HOT. DO NOT TOUCH HOT SURFACES.

8. Turn off the oven and let it cool. Thoroughly wipe down the cooking cavity with clean water. **Make sure all the degreaser is thoroughly wiped off oven door gaskets.**

NOTE: If not degreasing, you may add delimer during Step 3 above, or let the oven count down to its second stage (**CL:26**) **BEFORE** starting the deliming process.

NOTE: If the timer stops and the **SERVICE** light comes on, it means that there have been errors that

prevent the unit from completing its Clean Cycle. Take the following steps:

- 1) Perform a reset. With the unit turned off, press and hold the **COMBO** touch pad. Then press the **ON** touch pad to display any error codes.
- 2) If the error numbers displayed are 1 **and** 3, or 2 **and** 3, press **CLEAR**, and restart the Clean Cycle by entering "99" (00:99) on the timer. Add one cup of full strength degreaser and continue the Clean Cycle by pressing **START**.

- 3) If the error numbers are 1 **and** 2, or 6, call your authorized Groen Service Agency for immediate service.
- 4) If the error number displayed is 1 **or** 2, but not both, the unit may need more cleaning.

If there are other errors, refer to this manual's Troubleshooting Section (Page 24)

Clean Cycle Counter

The Convection Combo™ keeps track of completed Clean Cycles. To see this total, turn off the unit. Press and hold the 0 touch pad while turning on the unit. The total will show in the Time/Status display.

Maintenance

The Groen Convection Combo™ is designed for minimum maintenance. Certain parts may need replacement after prolonged use. If there is a need for service, only Groen personnel or authorized Groen representatives should perform the work.

If steam or condensate is seen leaking from around the door, take the following steps:

1. Check the door gasket. Use a 2" strip of paper closed in between the door and the gasket. If the paper is not snugly held in place, adjust the latch pin as indicated in Step #3. Replace the gasket if it is cracked or split.

2. Inspect the cooking chamber drain to be sure it is not blocked.
3. Adjust the latch pin as follows:
 - a. Loosen the lock nut at the base of the latch pin, and turn the latch pin ¼ turn clockwise. Re-tighten the lock nut.
 - b. After adjustment, run the unit to test for further steam leaks.
 - c. If there is still leakage, repeat the adjustment.
 - d. Continue adjusting the pin clockwise until the door fits tightly enough to prevent leaks.

Troubleshooting

A. Resetting the Solid State Controls

(If problems persist call an authorized Groen Service Agency)

If the controls stop responding to normal operations, or the unit is behaving oddly, reset the controls using the following procedure:

1. Switch off the power by pressing the **ON** touch pad.
2. While pressing the **COMBO** touch pad, switch the power back on. If no errors are present the unit will beep and show four zeroes in the display. If there are errors, the unit will **not** beep, but will display Service Codes, in the Time/Status **and** Cook displays. **Note the Service Codes**. Press **CLEAR** to exit Service Mode and refer to the following explanation of service messages.

B. Service Messages

There are two types of service messages:

1. Non-critical error: signaled by three quick beeps. The **SERVICE** light comes on for 15 seconds and then goes out.
2. Critical error: signaled by a continuous five second beep. The **SERVICE** light comes on and stays on.

If there is a non-critical error you may continue to operate the unit. When possible, check the Service Code. Turn off the unit by pressing the **ON** touch pad. While pressing the **COMBO** touch pad, switch the power back on. Note the numbers and refer to the Troubleshooting Guide which follows. Press **CLEAR** to exit the Service Mode. If there is a critical error, the unit will not operate in its current mode, but may operate in another. Check the Service Code as described above, and call your authorized Groen Service Agency.

Troubleshooting Guide

If a problem persists after taking the actions suggested below, call your authorized Groen service representative.

CODE	INDICATES	SUGGESTED ACTION
1	Low water level probe	Try cleaning steam generator to remove contamination from the probes. • If either code continues call your Groen Service Agency. • If both codes are displayed the unit will only operate in the Oven Mode.
2	High water level probe	• If only one code is displayed the unit will operate in all modes, but water may overflow from the generator into the cooking chamber during operations in either the Steam or Combo Modes.
3	Maximum generator fill time (5 minutes) has been exceeded.	Make sure the water supply is fully turned on and that hoses are not kinked or pinched. • If the code is still displayed the unit will operate in the Oven Mode only. • Call your Groen Service Agency
4	Faulty air probe	• The unit will operate in Steamer and Clean Cycle Modes only. • Call your Groen Service Agency
6	Faulty generator probe	• The unit will operate in Oven Mode only. • Call your Groen Service Agency
7	Time Between Fills	Check for a leaky fill valve. • The unit will operate in Oven Mode only. • Call your Groen Service Agency
8	Maximum generator drain time (three minutes) has been exceeded.	Inspect the drain line and remove any blockage. Make certain that the drain is free-vented as detailed in the Installation Section of this Manual. (Paragraph 4, Pages 7-8)

Mode Operation — After a Service Code Occurs

Mode	Service Code							
	1	2	3	4	6	7	8	1 & 2
Steam	Yes	Yes	No	Yes	No	No	No	No
Combo	Yes	Yes	No	No	No	No	No	No
Oven	Yes	Yes	Yes	No	Yes	Yes	Yes	Yes
Clean	Yes	Yes	No	Yes	No	No	No	No

Door Light: The door has a total of four light bulbs, two pair wired in series. If the top or bottom two bulbs fail to operate, replace each bulb individually to isolate the failed bulb. If all bulbs fail to operate, check the installation of the jumper cord between the door and oven front panel (see Step F and photo on page 19).

Diagrams & Schematics

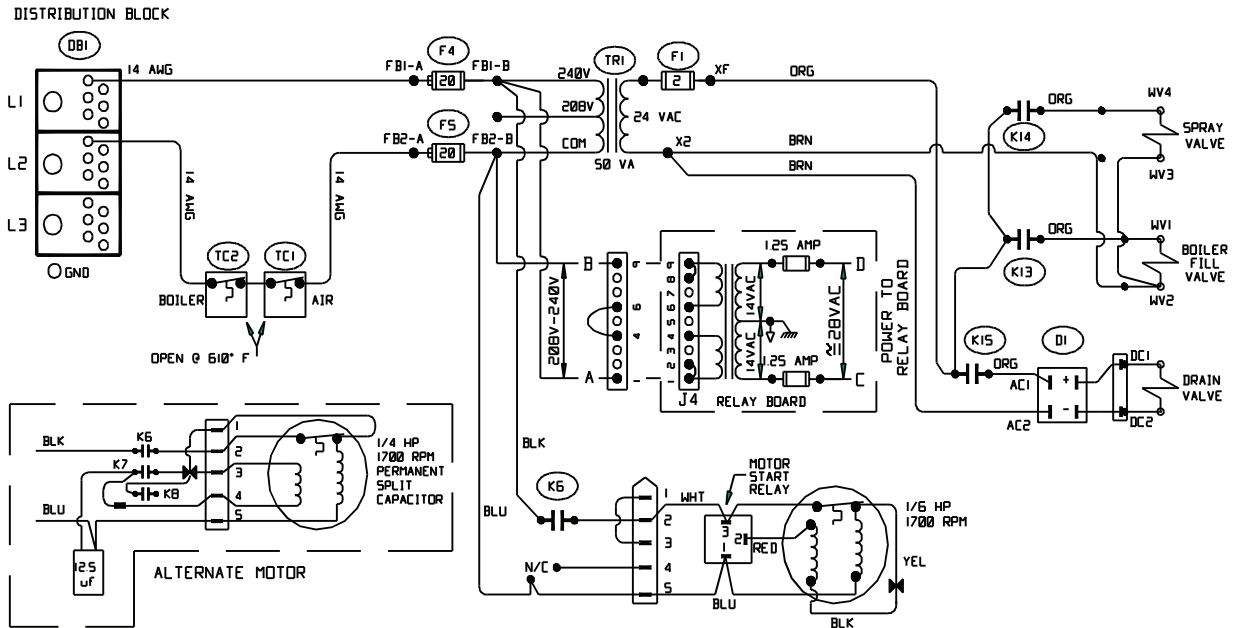

CC10-E Control Schematic

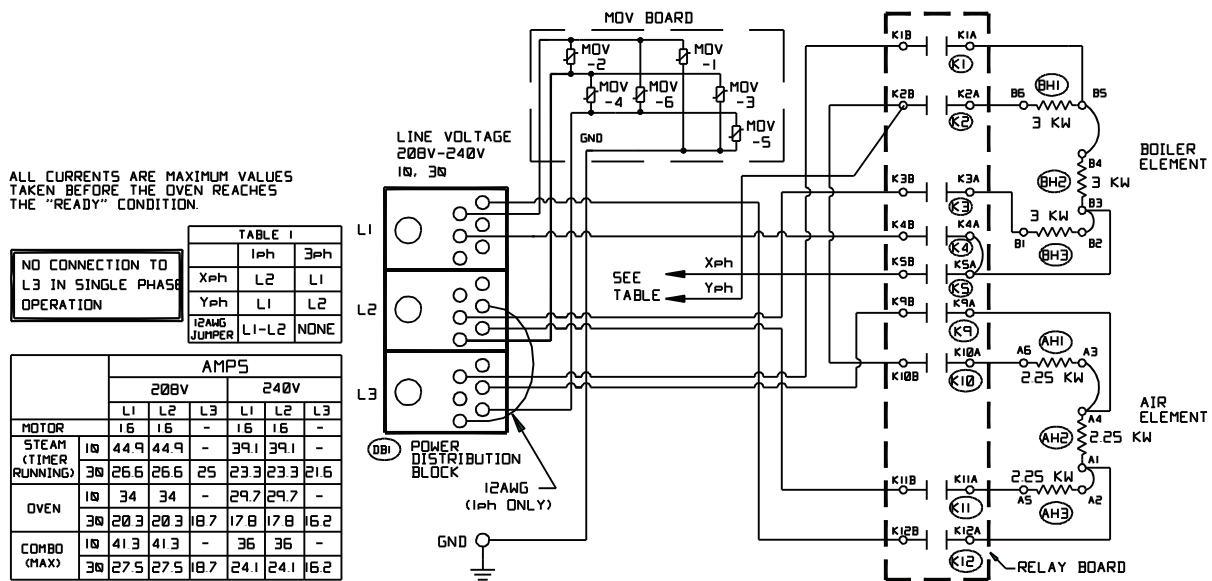

CC10-E Heater Schematic

Diagrams & Schematics, Continued

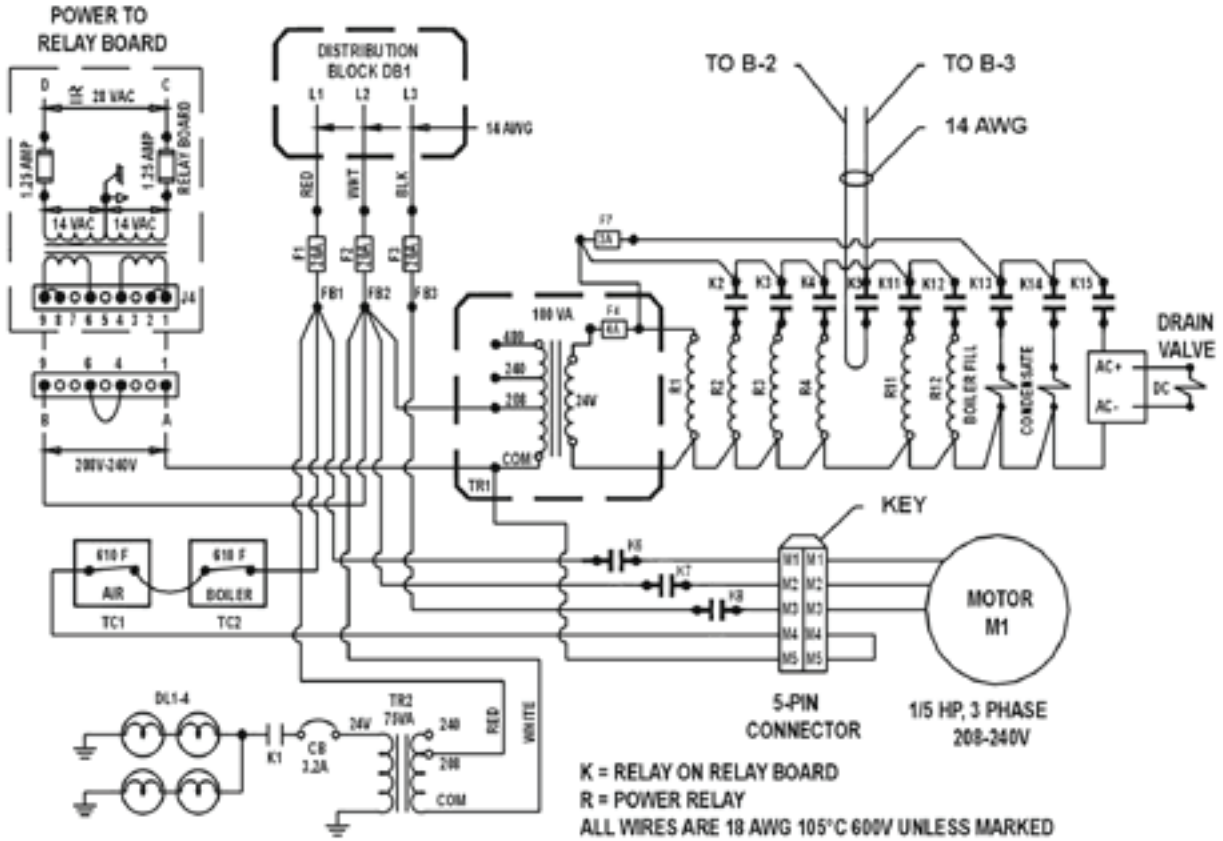

C/2-20E Control Schematic, 208/240 Volts

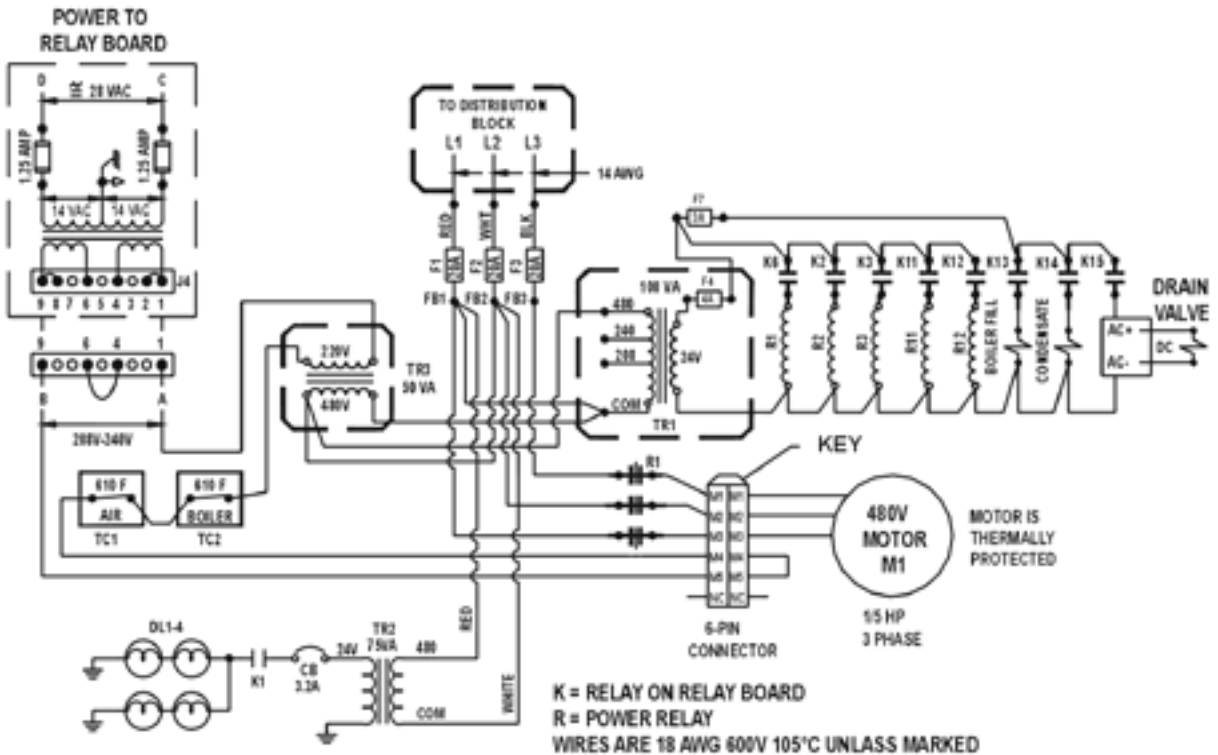

C/2-20E Control Schematic 480 Volts

Diagrams & Schematics, Continued

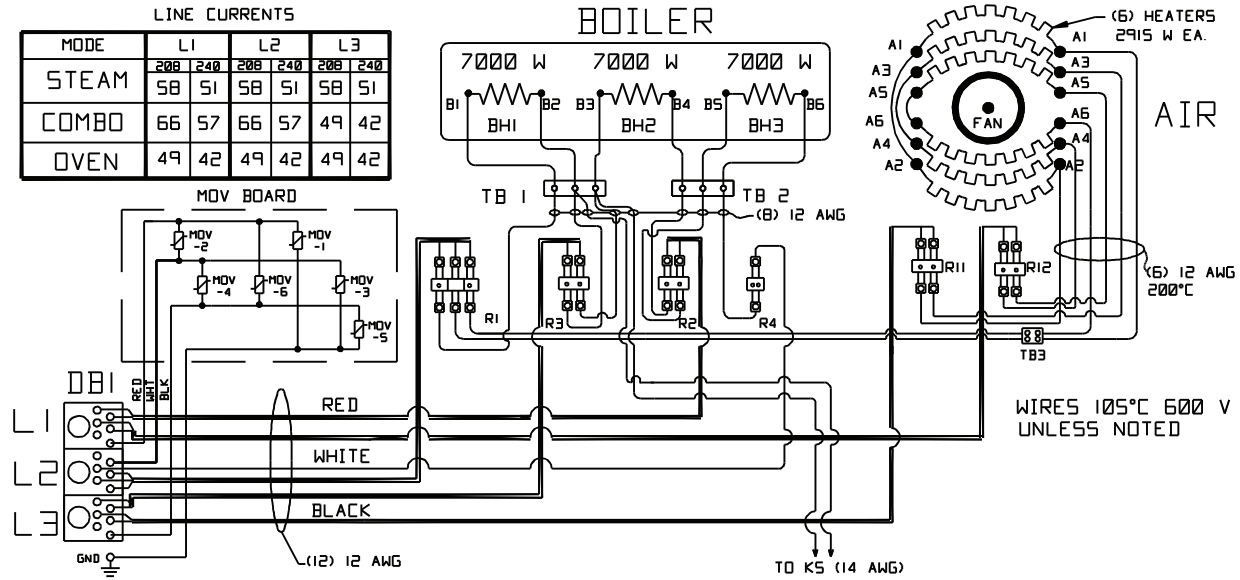

C/2-20E Heater Schematic, 208/240 Volts

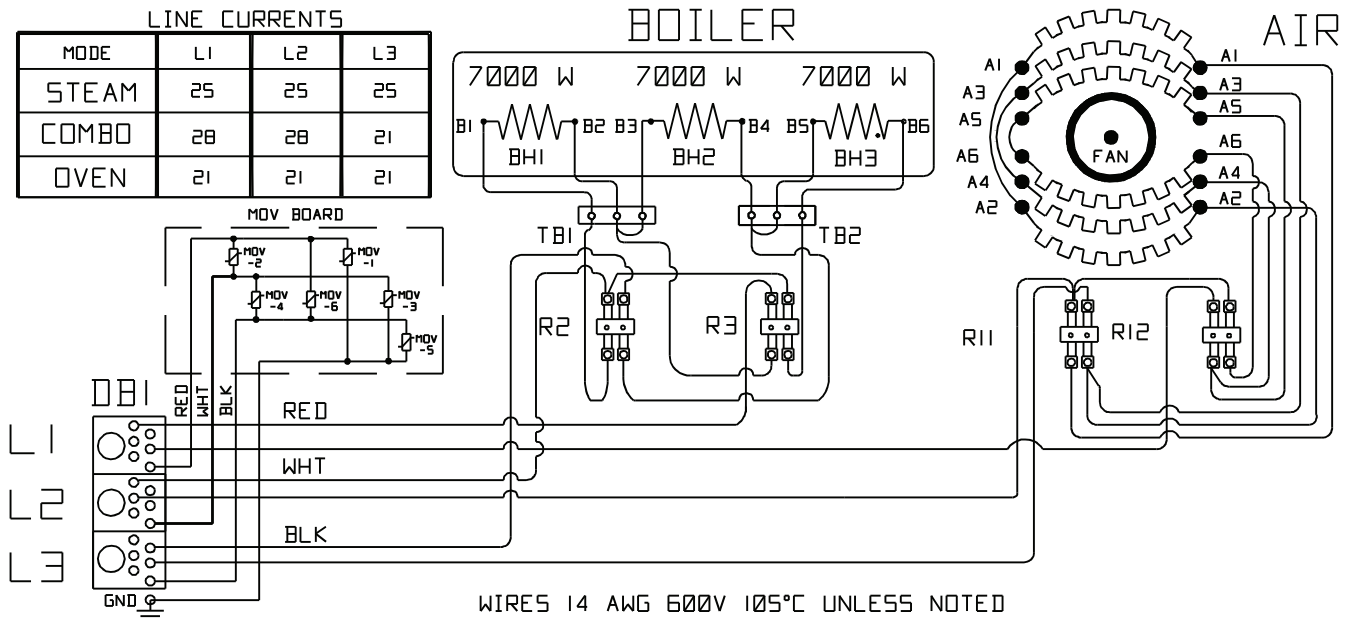

C/2-20E Heater Schematic, 480 Volts

Diagrams & Schematics, Continued

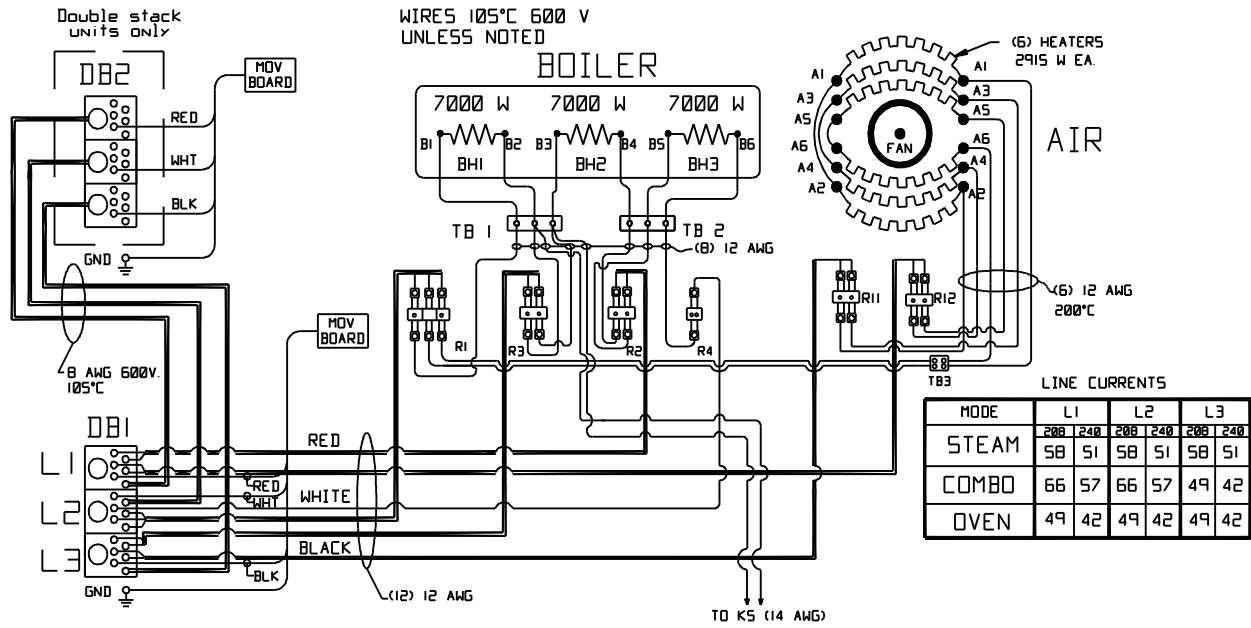

C/2-20E Heater Schematic 208/240 Volts
(Units That Meet Canadian Standards Association Requirements)