

# OPERATOR MANUAL

IMPORTANT INFORMATION, KEEP FOR OPERATOR

This manual provides information for:



## **TDB/8-20-CFC WATER JACKETED FUDGE KETTLE**

- Self-Contained
- Electrically Heated
- Table Top Mounted
- Tilting
- Power Agitator



**THIS MANUAL MUST BE RETAINED FOR FUTURE REFERENCE.  
READ, UNDERSTAND AND FOLLOW THE INSTRUCTIONS AND  
WARNINGS CONTAINED IN THIS MANUAL.**

### **FOR YOUR SAFETY**

Do not store or use gasoline or other flammable vapors and liquids in the vicinity of this or any other appliance.

### **NOTIFY CARRIER OF DAMAGE AT ONCE**

It is the responsibility of the consignee to inspect the container upon receipt of same and to determine the possibility of any damage, including concealed damage. Unified Brands suggests that if you are suspicious of damage to make a notation on the delivery receipt. It will be the responsibility of the consignee to file a claim with the carrier. We recommend that you do so at once.

Manufacture Service/Questions 888-994-7636.

PART NUMBER 121027, REV. E (4/06)

# G GROEN®



**UNIFIED BRANDS**  
FOODSERVICE EQUIPMENT SOLUTIONS  
A DOVER COMPANY

1055 Mendell Davis Drive  
Jackson, MS 39272  
888-994-7636, fax 888-864-7636  
unifiedbrands.net

## **IMPORTANT — READ FIRST — IMPORTANT**

- CAUTION:** BE SURE ALL OPERATORS READ, UNDERSTAND AND FOLLOW OPERATING INSTRUCTIONS, CAUTIONS, AND SAFETY INSTRUCTIONS IN THIS MANUAL.
- WARNING:** THIS UNIT IS INTENDED FOR USE IN THE COMMERCIAL HEATING, COOKING AND HOLDING OF WATER AND FOOD PRODUCTS, PER THE INSTRUCTIONS CONTAINED IN THIS MANUAL. ANY OTHER USE COULD RESULT IN PERSONAL INJURY OR DAMAGE TO THE EQUIPMENT AND WILL VOID WARRANTY.
- WARNING:** KETTLE MUST BE INSTALLED BY PERSONNEL QUALIFIED TO WORK WITH ELECTRICITY. IMPROPER INSTALLATION CAN RESULT IN INJURY TO PERSONNEL AND/OR DAMAGE TO EQUIPMENT.
- WARNING:** AVOID ALL DIRECT CONTACT WITH HOT EQUIPMENT SURFACES. DIRECT SKIN CONTACT COULD RESULT IN BURNS.
- WARNING:** AVOID ALL DIRECT CONTACT WITH HOT FOOD OR WATER IN THE KETTLE. DIRECT CONTACT COULD RESULT IN BURNS.
- CAUTION:** DO NOT OVER FILL THE KETTLE WHEN COOKING, HOLDING OR CLEANING. KEEP LIQUIDS A MINIMUM OF 4- 5" (10-15 cm) BELOW THE KETTLE BODY RIM TO ALLOW CLEARANCE FOR STIRRING AND SAFE PRODUCT TRANSFER.
- WARNING:** TAKE SPECIAL CARE TO AVOID CONTACT WITH HOT KETTLE BODY OR HOT PRODUCT WHEN ADDING INGREDIENTS, STIRRING OR TRANSFERRING PRODUCT TO ANOTHER CONTAINER.
- WARNING:** WHEN TILTING KETTLE FOR PRODUCT TRANSFER:
- 1) WEAR PROTECTIVE OVEN MITT AND PROTECTIVE APRON.
  - 2) USE CONTAINER DEEP ENOUGH TO CONTAIN AND MINIMIZE SPLASHING.
  - 3) PLACE CONTAINER ON STABLE, FLAT SURFACE, AS CLOSE TO KETTLE AS POSSIBLE.
  - 4) DO NOT STAND IN POUR PATH OF HOT CONTENTS.
  - 5) POUR SLOWLY, MAINTAIN CONTROL OF KETTLE BODY HANDLE AT ALL TIMES, AND RETURN KETTLE BODY TO UPRIGHT POSITION AFTER CONTAINER IS FILLED OR TRANSFER IS COMPLETE.
  - 6) DO NOT OVER FILL CONTAINER. AVOID DIRECT SKIN CONTACT WITH HOT CONTAINER AND ITS CONTENTS.
- CAUTION:** KEEP FLOORS IN FRONT OF KETTLE WORK AREA CLEAN AND DRY. IF SPILLS OCCUR, CLEAN IMMEDIATELY, TO AVOID SLIPS OR FALLS.
- WARNING:** TO AVOID INJURY, READ AND FOLLOW ALL PRECAUTIONS STATED ON THE LABEL OF THE WATER TREATMENT COMPOUND.
- WARNING:** BEFORE REPLACING ANY PARTS, DISCONNECT THE ELECTRIC POWER SUPPLY.
- WARNING:** KEEP WATER AND SOLUTIONS OUT OF CONTROLS. NEVER SPRAY OR HOSE THE KETTLE BODY OR ELECTRICAL CONNECTIONS.
- CAUTION:** MOST CLEANERS ARE HARMFUL TO THE SKIN, EYES, MUCOUS MEMBRANES AND CLOTHING. TAKE PRECAUTIONS: WEAR RUBBER GLOVES, GOGGLES OR FACE SHIELD AND PROTECTIVE CLOTHING. CAREFULLY READ THE WARNINGS AND FOLLOW THE DIRECTIONS ON THE LABEL OF THE CLEANER TO BE USED.
- CAUTION:** USE OF ANY REPLACEMENT PARTS OTHER THAN THOSE SUPPLIED BY GROEN OR THEIR AUTHORIZED DISTRIBUTORS CAN CAUSE OPERATOR INJURY AND DAMAGE TO THE EQUIPMENT, AND WILL VOID ALL WARRANTIES.
- IMPORTANT:** SERVICE PERFORMED BY OTHER THAN FACTORY AUTHORIZED PERSONNEL WILL VOID WARRANTIES.

# Table of Contents

IMPORTANT OPERATOR WARNINGS.....	2
REFERENCES .....	3
EQUIPMENT DESCRIPTION.....	4
INSPECTION AND UNPACKING .....	5
INSTALLATION.....	5
OPERATION .....	6
CLEANING.....	7
MAINTENANCE .....	8
TROUBLESHOOTING .....	10
SPECIFICATIONS.....	11
PARTS LIST .....	12
ELECTRICAL SCHEMATICS .....	16
MAINTENANCE LOG .....	19
WARRANTY .....	20

## References

**KLENZADE SALES CENTER ECOLAB, Inc.**  
370 Wabasha  
St. Paul, Minnesota 55102  
800/352-5326 or 612/293-2233

**NATIONAL FIRE PROTECTION ASSOCIATION**  
60 Battery March Park  
Quincy, Massachusetts 02269

**NFPA/70 The National Electrical Code**

**NATIONAL SANITATION FOUNDATION**  
3475 Plymouth Rd.  
Ann Arbor, Michigan 48106

**UNDERWRITERS LABORATORIES, INC.**  
333 Pflingsten Road  
Northbrook, Illinois 60062

**ZEP MANUFACTURING CO.**  
1310-T Seaboard Industrial Blvd.  
Atlanta, Georgia 30318

## Equipment Description

The Groen TDB/8-20-CFC cooker/mixer consists of a water-jacketed kettle with a motor-driven mixer. The 20 quart tilting kettle is equipped with electronically controlled electric heaters for the jacket.

The kettle of Model TDB/8-20-CFC is constructed of stainless steel welded into one piece. The body has a reinforced rim and a butterfly-shaped pouring lip. It is fitted with an integral water jacket. The kettle exterior has a bright semi-deluxe finish. The kettle's pouring height allows filling pans up to 4 inches high on a table top.

The kettle's internal electric heaters provide uniform heat in three stages, with jacket temperature control over the range of 140 to 180°F (60 to 80°C).

In addition to the three-stage adjustable thermostat for operating control, the unit has a high limit thermostat, as a safety feature, plus an indicator lamp and water gauge glass, with which to monitor kettle operation.

Mixing is controlled with a power switch. The switch doubles as a circuit breaker for motor protection. The agitator continuously sweeps the side and bottom of the kettle.

Electric power for the kettle and mixer is supplied through a plug-in power cord, which is furnished with the unit. Standard unit operation requires connection to single phase, 115 VAC, 60 Hz electrical service. The unit must be supplied from a separate, dedicated 20A branch circuit.

<b>COOKER/MIXER CHARACTERISTICS</b>		
Kettle Capacity	20 Quarts	18.8 Liters
Diameter	14 inches	36 cm
Depth	11 Inches	28 cm
<b>SPACE REQUIRED (Approximate)</b>		
Side to Side	19 inches	48 cm
Vertical	30 inches	76 cm

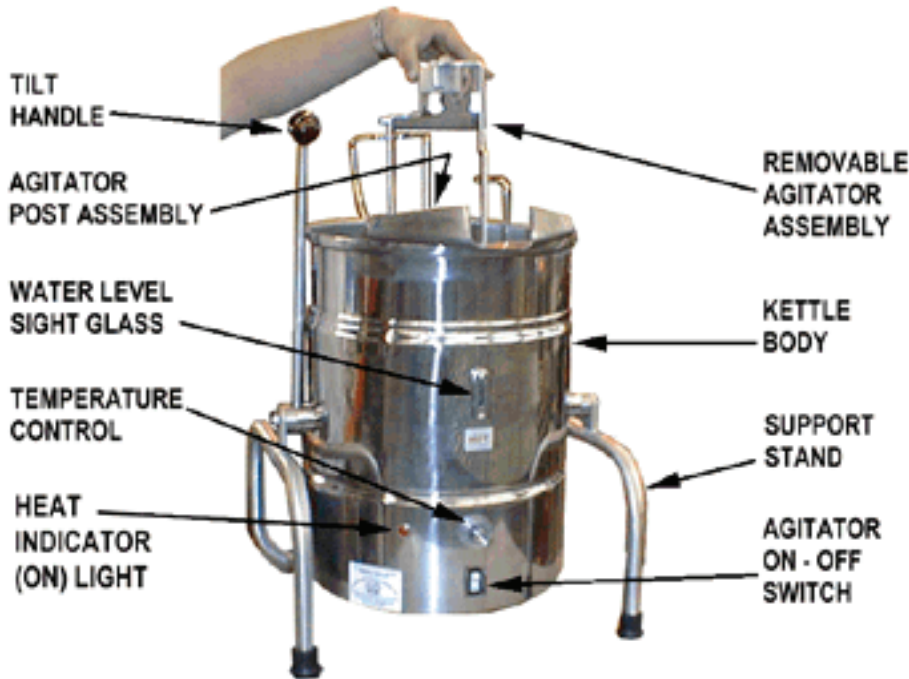

The Agitator fits over the agitator post inside the kettle.

## Inspection & Unpacking

The unit will arrive in a shipping carton which has been strapped or stapled shut. Immediately upon receipt, inspect the carton carefully for exterior damage.

**CAUTION**  
**SHIPPING STRAPS ARE UNDER TENSION AND CAN SNAP BACK WHEN CUT. TAKE CARE TO AVOID PERSONAL INJURY OR DAMAGE TO THE UNIT BY STAPLES LEFT IN THE WALLS OF THE CARTON.**

Carefully cut the straps around the carton and detach the sides of the box. Pull the carton up off the unit.

Thoroughly inspect the unit for concealed damage. Report any shipping damage or incorrect shipments to the delivery agent.

Write down the model number, serial number, and installation date, and file this information for future reference. Space for these entries is provided at the top of the Service Log on Page 18 of this manual.

When installation is to begin, lift the unit straight up, obtaining help as needed. Examine packing materials to be sure loose parts are not discarded with the materials.

## Installation



**WARNING**  
**IMPROPER INSTALLATION CAN RESULT IN INJURY TO PERSONNEL AND/OR DAMAGE TO EQUIPMENT.**

**THE UNIT MUST BE GROUNDED. DO NOT FORCE THE PLUG OR ALTER IT TO OVERRIDE GROUNDING FEATURES.**

The Groen cooker/mixer is provided with complete internal wiring. It is ready for immediate connection. The completed unit was operated at the factory to check the controls, mixer and jacket heater.

Any mechanical or electrical changes must be approved in by Groen's Food Service Engineering Department.

1. Set the kettle in place and level it.
2. Provide electrical power as specified on the electrical information plate attached to the equipment. Observe local codes and/or The National Electrical Code in accordance with ANSI/NFPA 70 - (current edition).

3. Confirm that the jacket water level is at the middle of the sight glass. If the level is low, use the following procedure for adding water:
  - a. If you are replacing water lost by evaporation, use distilled water. To replace treated water that ran out of the jacket, prepare more treated water as described in Water Treatment, Page 9.
  - b. Remove the plug from the elbow.
  - c. Add water or treated water through the elbow, until the water level rises to the middle of the sight glass. Note that added water must raise the level in the whole jacket, so a substantial amount of water will be needed to make a small change in the level.
  - d. Replace the plug in the elbow. Follow instructions under "Jacket Filling and Water Treatment" in the "Maintenance" section of this manual.

## ELECTRICAL CHARACTERISTICS

Frequency	60 Hz	50 Hz
Voltage	120	240
<b>Kettle</b>		
Power, KW	1.9	1.9
Draw, AMP	16.5	8.3
<b>Motor</b>		
Power, HP	1/4	1/4
Full-load current, AMP	2.5	1.3
<b>Capacitance</b>		
Start	25	25
Run	7.5	7.5
<b>Service Power Recommendation</b>		
Service suggested	20 AMP, 1 PH	15 AMP, 1 PH

## Operation

### A. Controls

The operator controls the cooker/mixer with the:

1. Temperature control dial. The dial turns electric power for the heaters on or off and sets the operating temperature of the kettle, with a maximum jacket temperature of 180BF. (Maximum temperature of a product heated by the kettle is less than 180B, due to heat loss out the top of the kettle.)
2. Mixer power switch, a switch that turns electric power for the motor drive on and off.

### B. To Operate the Kettle (Heating)

1. **Every day** make sure that the jacket water level is at the middle of the sight glass. If the level is low, see "Jacket Filling" in the "Maintenance & Cleaning" section of this manual.

**CAUTION**  
**DO NOT OPERATE THE KETTLE WHEN THE WATER LEVEL IN THE JACKET IS LOW. YOU MAY BURN OUT THE HEATING ELEMENTS.**

2. Plug in the power cord. If necessary, turn on the power at the circuit breaker or fuse box.
3. Turn the temperature control dial to the desired setting. The red indicator light indicates that the kettle is heating. Cycling of

the light on and off indicates that the kettle is being held at the set temperature. Once in each cycle the temperature controller will make a clicking sound as it cycles on and off. This is normal.

4. To shut down the kettle, turn the temperature control dial to "OFF."
5. For prolonged shut-down or before cleaning the outside of the unit, unplug the unit.

### C. To Operate the Mixer

1. Place the agitator on the shaft.
2. Press the power switch to the "ON" position.
3. To shut down the mixer, press the power switch to "OFF."
4. For prolonged shut-down or when the outside of the unit is to be cleaned, unplug the unit.

## Cleaning

### 1. Suggested Tools:

- Cleaner, such as Klenzade HC-10 or HC-32 from ECOLAB, Inc.
- Kettle brushes in good condition.
- Sanitizer such as Klenzade XY-12.
- Film remover such as Klenzade LC-30.

### 2. Precautions

Before cleaning, shut off the kettle by turning the thermostat dial to "OFF" and unplug the unit or shut off its electric power at a remote switch, such as the circuit breaker.

**WARNING**  
KEEP WATER AND SOLUTIONS AWAY FROM CONTROLS AND ELECTRICAL EQUIPMENT. NEVER SPRAY THE KETTLE BODY OR ELECTRICAL CONNECTIONS.



**CAUTION**  
MOST CLEANERS ARE HARMFUL TO THE SKIN, EYES, MUCOUS MEMBRANES, AND CLOTHING. TAKE PRECAUTIONS. WEAR RUBBER GLOVES, GOGGLES OR FACE SHIELD, AND PROTECTIVE CLOTHING. READ THE WARNINGS AND FOLLOW THE DIRECTIONS ON THE CLEANER LABEL.

### 3. Procedure

- Clean food-contact surfaces as soon as possible after use. If the unit is in continuous use, thoroughly clean and sanitize the interior and exterior at least once every 12 hours.



**WARNING**  
AVOID ANY DIRECT CONTACT WITH HOT SURFACES. DIRECT SKIN CONTACT COULD RESULT IN BURNS.

- Scrape and flush out food residues. Be careful not to scratch the kettle with metal implements.
- Prepare a hot solution of the detergent/cleaning compound as instructed by the supplier. Clean the unit thoroughly. A cloth moistened with cleaning solution can be used to clean controls and electrical conduits.
- Rinse the agitator parts and the inside of the kettle **thoroughly** with hot water to remove every trace of detergent. Drain them completely and allow them to AIR dry or wipe them dry. (The agitator may be cleaned in a dishwasher).
- As part of the daily cleaning program, clean soiled external and internal surfaces. Remember to check the sides and back of the unit.
- To remove stuck materials, use a brush, sponge, cloth, plastic or rubber scraper, or plastic wool with the cleaning solution.



Use a sponge, cloth or plastic brush to clean the kettle.



Scrapers or steel wool can harm the kettle surface.

To reduce effort required in washing, let the detergent solution sit in the kettle and soak into the residue. Do NOT use abrasive materials or metal tools that might scratch the surface. Scratches make the surface harder to clean and provide places for bacteria to grow.

- Do NOT use steel wool, which may leave particles in the surface and cause eventual corrosion and pitting.
- g. The outside of the unit may be polished with a stainless steel cleaner such as “Zepper” from Zep Manufacturing Co.
- h. When equipment needs to be sanitized, use a solution equivalent to one that supplies 200 parts per million available chlorine. Obtain advice on sanitizing agents from your supplier of sanitizing products. Following the supplier’s instructions, apply the agent after the unit has been cleaned and drained. Rinse off the sanitizer thoroughly.

**NOTICE: NEVER LEAVE A CHLORINE SANITIZER IN CONTACT WITH STAINLESS STEEL SURFACES LONGER THAN 30 MINUTES. LONGER CONTACT CAN CAUSE STAINING AND CORROSION.**

- i. It is recommended that the equipment be sanitized just before use.
- j. If there is difficulty removing mineral deposits or a film left by hard water or food residues, clean the kettle thoroughly and use a deliming agent, like Groen Delimer/Descaler (Part Number 114800) or Lime-Away® from Ecolab, in accordance with the manufacturer’s directions. Rinse and drain the unit before further use.
- k. If cleaning problems persist, contact your cleaning product representative for assistance. The supplier has a trained technical staff with laboratory facilities to serve you.

## Maintenance

**NOTICE: Contact Groen or an authorized Groen representative when repairs are required.**

### 1. Periodic Maintenance

A Maintenance & Service Log is provided at the back of this manual. Each time there is maintenance performed on your Groen kettle, enter the date the work was done, what was done, and who did it. Keep this manual on file and available for operators to use.

Periodic inspection will minimize equipment down time and increase the efficiency of operation. The following points should be checked often:

- a. The jacket water level should be at the middle of the gauge glass when the kettle is at room temperature. If the level is low, see “Jacket Filling” below.



**WARNING  
SHUT OFF THE ELECTRIC POWER TO  
THE UNIT BEFORE YOU OPEN THE  
BOTTOM COVER.**

- b. The inside of all housings should be kept clean and dry.

- c. Electrical wiring should be kept securely connected and in good condition.
- d. The fill plug on the elbow at the back of the kettle should have “C” holes in it. These holes must be kept free of debris for proper venting. **Plugging the holes could cause pressure to build!**

### 2. Jacket Filling and Water Treatment

The jacket must be kept filled with the proper amount of treated water. From time to time, you will need to restore the jacket water to the proper level, because its water slowly evaporates. You may also need to replace treated water, if the jacket is drained for any reason. The procedure for adding water follows:

- a. If you are replacing water lost by evaporation, use distilled water. If you are replacing treated water that ran out of the jacket, prepare more treated water as directed below.
- b. Remove the plug from the elbow on the back of the kettle body.
- c. Add water or treated water through the elbow, until the water level rises to the



middle of the sight glass. Since the water you are adding must raise the level in the whole jacket, a substantial amount of water is needed to make a small change in the level.

- d. Replace the plug in the elbow.

### 3. Water Treatment Procedure

**WARNING**  
**TO AVOID INJURY, READ AND FOLLOW ALL PRECAUTIONS STATED ON THE LABEL OF THE WATER TREATMENT COMPOUND.**

Obtain water treatment compound and a pH test kit from your supplier, or directly from your Groen Parts Distributor.

- a. Place exactly one gallon of water in the mixing container. Distilled water is recommended.
- b. Hang a strip of pH test paper on the rim of the container. Allow about one inch of the strip below the surface of the water.
- c. Measure the water treatment compound you will be using. (One way to do this is to add the compound to the water from a measuring cup.)



To add water to the jacket, remove the fill plug.  
(Note the venting holes)

- d. Stir the water continuously, while you slowly add water treatment compound, until the water reaches a pH between 10.5 and 11.5. Judge the pH by frequently comparing the color of the test strip with the color chart provided in the pH test kit.

Color blind people mixing the treated water solution must use an electro-analytical instrument to measure pH or have a person who is not color blind check the test strip color level.

- e. Record the exact amounts of water and treatment compound used. These amounts may be used again, if the same sources of water and compound are used to refill the jacket in the future. However, it is advisable to check the pH every time treated water is prepared.

### 5. Component Replacement



**WARNING**  
**BEFORE REPLACING ANY PARTS, DISCONNECT THE UNIT FROM THE ELECTRIC POWER SUPPLY.**

Internal wiring is marked as shown on the circuit schematic drawings. Be sure that new components are wired in the same manner as those being replaced.

## Troubleshooting

Your Groen cooker/mixer will operate smoothly and efficiently if properly maintained. However, the following is a list of checks to make in the event of a problem. Wiring diagrams are provided on pages 16 and 17 of this manual. **Items marked with a Y should only be performed by a qualified Groen Service Representative.**

**WARNING**  
**USE OF ANY REPLACEMENT PARTS OTHER THAN THOSE SUPPLIED BY GROEN OR THEIR AUTHORIZED DISTRIBUTORS CAN CAUSE INJURY TO THE OPERATOR AND DAMAGE TO THE EQUIPMENT AND WILL VOID ALL WARRANTIES.**

SYMPTOM	WHO	WHAT TO CHECK
		Items marked with (Y) should only be done by a factory-authorized service rep.
Kettle will not heat, and heating indicator will not come on.	User	a. That unit is firmly plugged into outlet. b. That branch circuit is on. Check fuse or circuit breaker for the outlet.
	Auth Service Rep. Only	c. Probe may be open. Continuity should measure 540 to 600 Ω at room temperature. Y d. The over-temperature switch may be faulty or open. The switch should open at ± 195°F. Y e. Defective temperature controller. Y f. Loose wire. Y
Kettle will not heat, but heating indicator comes on.	User	a. Check for proper water level. Fill as necessary (See filling instructions).
	Auth Service Rep. Only	b. Heating element may be open. Check for continuity. Y c. Loose wire. Y
Kettle exceeds set temperature	User	a. Temperature control setting. b. Check for proper water level. Fill as necessary (See filling instructions).
	Auth Service Rep. Only	c. Probe not fully inserted into water jacket. Y d. Probe type incorrect for controller (see NOTE below). Y e. Defective temperature controller. Y
Kettle does not get hot enough.	User	a. Temperature control setting. b. Check for proper water level. Fill as necessary (See filling instructions).
	Auth Service Rep. Only	c. Probe type incorrect for controller (see NOTE below). Y d. Check probe resistance. Y e. Defective temperature controller. Y
Kettle heats but motor will not run.	User	a. Fudge may be too thick. Lift agitator off the top of the shaft and restart the motor. If the shaft turns, the fudge is too thick. Add water until the motor will turn.
	Auth Service Rep. Only	b. Loose wire. Y

SYMPTOM	WHO	WHAT TO CHECK
		Items marked with (Y) should only be done by a factory-authorized service rep.
Motor will not run; kettle does not heat.	User	a. Check that plug is firmly plugged into wall outlet. b. Check that branch circuit is on. Check fuse or circuit breaker for the outlet. Other equipment on the same circuit may cause an overload.
	Auth Service Rep. Only	c. Loose wire.Y
Motor circuit breaker trips frequently	User	a. Fudge may be too thick. Lift agitator off the top of the shaft and restart the motor. If the shaft turns, the fudge is too thick. Add water until the motor will turn.
	Auth Service Rep. Only	b. Drive shaft bushing binding. Remove agitator. Put two drops mineral oil on top of the shaft on the inside of the white plastic bushing. When you turn on the motor the bushing should not rotate. If it does, replace it.Y c. Start/run capacitors reversed. Check wiring diagram.Y
Motor circuit breaker trips frequently (Continued)	Auth Service Rep. Only	d. Start relay stuck in closed position. Measure current in start winding (red wire). After motor starts current should drop to zero.Y
Kettle makes grinding noise	Auth Service Rep. Only	Some amount of noise is normal for this kettle and does not necessarily indicate a problem.. a. Drive belt may be loose or misaligned.Y b. Gearbox pulley not properly secured to shaft.Y c. Drive shaft bushing is binding.Y

**NOTE:** Probes and controllers in kettles built before 1989 are not compatible with those built in 1989 or later. The earlier controller (silver colored model 1020 – Groen Part Number 072038) must be used with the probe identified by brown lead wires (Groen Part Number 073414). The later version controller (Groen Part Number 077889) must be used with the probe identified by yellow sleeving on the lead wires (Groen Part Number 086407), or improper heating will result.

### Electrical Specifications

Probe Resistance	Before Jan 1, 1989 after Jan 1, 1989	508 Ohms ± two percent in a stirred ice bath 500 Ohms ± one percent in a stirred ice bath
Motor winding resistance at 72°F	120 Volts	Red to Yellow 23.6 Ohms Blue to Yellow 3.1 Ohms
	240 Volts	Red to Yellow 19.7 Ohms Blue to Yellow 15.1 Ohms
No-load running current	120 Volts	1.8 Amperes
	240 Volts	1.0 Amperes
Full-load running current	120 Volts	2.5 Amperes
	240 Volts	1.3 Amperes
Motor Speed	60 Hz	3382 RPM at full load
	50 Hz	2810 RPM at full load
Agitator Speed (no-load)	60 Hz	42 RPM
	50 Hz	35 RPM
Motor start/circuit breaker trip current	120 Volts	2.9 Amperes
	249 Volts	1.35 Amperes
Over-temperature switch opening temperature		195°F ± 6°F
Heater Power 120 Volts and 240 Volts		1850 Watts

**PARTS LIST**  
 (Units Build before January 1, 1989)

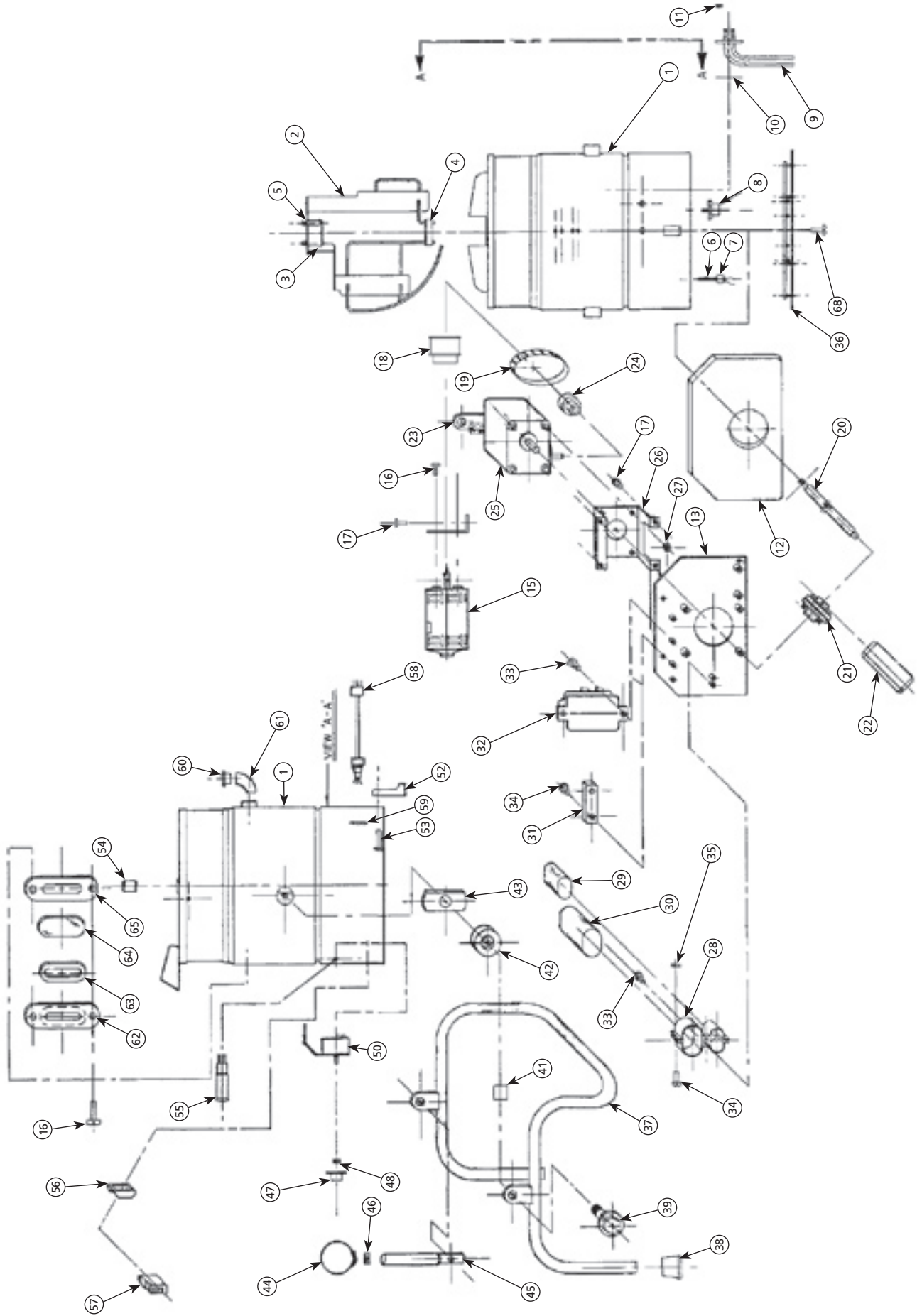

# OM-TDB/8-20-CFC

## Parts List

(Units Built before January 1, 1989)

Key	Description	Part No.	Key	Description	Part No.
1	Kettle body & trunnion assy.	072007	23	Cover bracket	072051
2	Agitator subassembly	072017	24	Pulley	072061
3	Guide	072016	25	Gear Box	072068
4	Support ring	072015	26	Reducer Bracket	072067
5	1/4-20x3/4 thumb screw	002080	27	Hex Nut #5/16 - 18	005574
6	Temperature probe	073414	28	Bracket, Capacitor Holder	074512
7	Connector male	070175	29	Capacitor 7.5 $\mu$ f	074511
8	Thermostat Sensor	074529	30	Capacitor 25 $\mu$ f	074510
9	Heating element 115V	072039	31	Terminal block	056746
10	Gasket	003494	32	Relay motor starting 115v	074518
11	1/4-20 kep nut	012940	33	6-32x3/16 lg rd hd mach screw	058599
12	Spacer	072040	34	6-32x5/8 lg rd hd mach screw	056745
13	Plate subassembly	072010	35	6-32 nut hex	012602
14	Motor bracket	072065	36	Cover assy	074525
15	Motor, 3382 rpm	074516	37	Frame assy	072042
16	8-32x1/2 rd hd mach screw	012970	38	Leg tip	072072
17	1/4-20x1/2 hex hd cap screw	005608	39	d -24x1d lg hex hd cap screw	072074
18	Flanged pulley	072060	40	8-32x1/2 lg rd hd machine screw	012970
19	Timing belt	072063	41	Plain cylindrical bearing	072050
20	Shaft	072064	42	Washer	072053
21	Flexible Coupling	072051	43	Spacer	072052
22	Split Pin	072061	44	Knob maroon ball	012691
			45	Handle	072021
			46	Ring tolerance	012692
			47	Thermostat Knob	073413
			48	Grommet	074820
			49	Bracket	072023
			50	Temperature controller	072038
			51	6-32 x3/8 lg rd hd slot screw	013419
			52	Stop	072056
			53	#10 - 32x1/4 lg pan hd screw	002962
			54	Bearing agitator	072049
			55	Lamp pilot 115v 1/3w	002986
			56	Switch guard	072057
			57	Circuit breaker magnetic	074513
			58	Cord & plug assy	074812
			59	1/2 NPT nut, bonding	005487
			60	Pipe plug 3/4 npt w/hole	074528
			61	Elbow st. 90x3/4 NPT	010668
			62	Glass cover	072028
			63	Glass gasket	072026
			64	Glass	072027
			65	Cover gasket	072025
			68	Truss Head Screw 8-32x1/2	009696

# PARTS LIST

(Units Built after January 1, 1989)

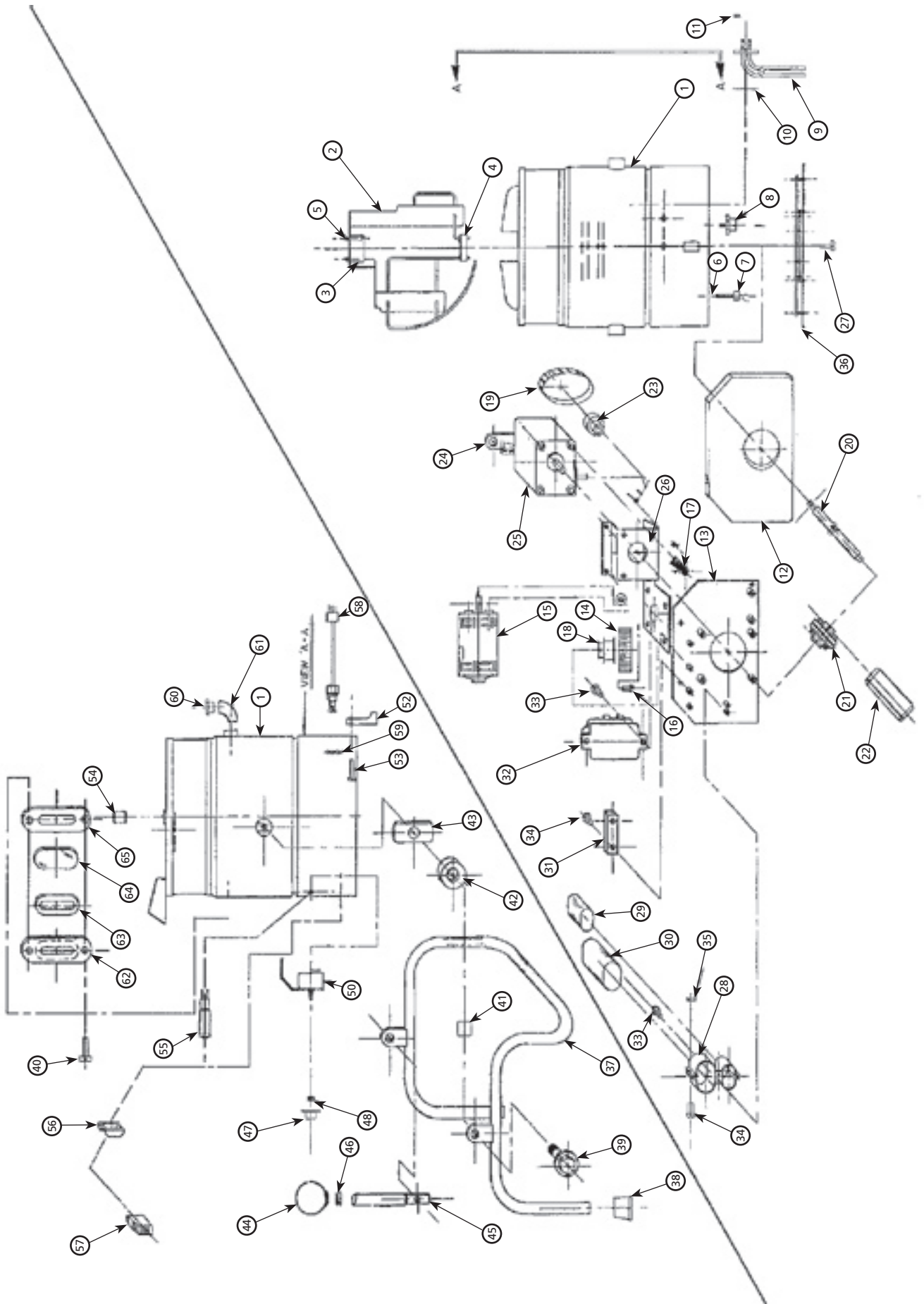

**TDB/8-20 CFC - Parts List**

Key	Description	Part No.	Key	Description	Part No.	Key	Description	Part No.
<b>AGITATOR PARTS</b>								
1	Kettle Body & Trunnion Assy.	MS72007	55	Lamp pilot 115V 1/3W	002986	<b>Frame and External Parts</b>		
2	Agitator subassembly	072017	55	Lamp pilot 240V 1/3W	016028	36	Cover assy	074525
3	Guide	072016	56	Switch guard	072057	37	Frame assy	072042
4	Support ring	072015	57	Circuit breaker magnetic 115V	074513	38	Leg, Tip Crutch	002032
5	1/4-20 x 3/4 thumb screw	002080	57	Circuit breaker magnetic 240V	077883	39	3/8 - 24 x 1 - 3/8 Trunion Bolt	088093
<b>ELECTRICAL PARTS &amp; RELATED HARDWARE</b>								
6	Temperature probe	086410	58	Cord & plug assy 115V - 6'	149179	40	8-32 x 1/2 rd hd mach screw	012970
7	Connector male	070175	58	Cord & plug assy 240V - 6'	160228	41	Plain cylindrical bearing	072050
8	Thermostat sensor	074529	59	1/2 NPT nut, bonding	005487	42	Washer	072053
9	Heating element 115V	072039	<b>Gear Reducer and Related Parts</b>			43	Spacer	072052
9	Heating element 240V	077882	12	Spacer	072040	44	Knob maroon ball	012691
10	Gasket (Heater)	003494	13	Plate subassembly	072010	45	Handle	072021
11	1/4-20 kep nut	012940	14	Blower Wheel	086405	46	Ring tolerance	012692
15	Motor, 3382 rpm - 115 V	074516	16	8-32 x 1/2 rd hd mach screw	069790	NS	Handle & Knob Assy. Complete	072020
15	Motor, 3382 rpm - 240 V	086646	17	1/4"-20 x 1/2 hex hd cap screw	005608	52	Bracket, Stop	072056
28	Bracket Capacitor Holder	074512	18	Flanged pulley motor	086406	53	#10 - 32 x 1/4 lg pan hd screw	002962
29	Capacitor 7.5 µF	074511	18	Set Screw #8-32 x 3/8	149013	54	Bearing agitator	072049
30	Capacitor 25 µF	074510	19	Timing belt	072063	60	Pipe plug 3/4 NPT, w/vent	074528
31	Terminal block	056746	20	Shaft	072064	61	Elbow St. 90 x 3/4 NPT	010668
32	Relay motor starting 115v	074518	21	Coupling	072058	62	Glass cover	072028
32	Relay motor starting 240V	077886	22	Spring Pin 5/32 x 1-3/8 ss	072062	63	Glass gasket	072026
33	6-32 x 3/16 lg rd hd mach screw	058599	23	Unflanged pulley	072061	64	Glass	072027
34	6-32 x 5/8 lg rd hd mach screw	056745	23	Set Screw #10-32 x 1/2	149014	65	Cover gasket	072025
35	6-32 nut hex	012602	24	Assy., Cover bracket (See Note 1)	148059	<b>NOTE 1:</b>		
47	Temperature Controller Knob	073413	25	Worm Gear Reducer (see Note 1)	148058	For units manufactured after September 2005 items 24, 25 & 26 may be replaced.		
50	Temperature controller	077889	26	Bracket Motor/Reducer mounting (see Note 1)	148060	For units manufactured before September 2005 order kit 148061		
NS	Wire Harness	074814	NS	Kit - Gear Reducer & Brackets (see Note 1)	148061	For units prior to 4/06 - #58 (115V) was 074812, #58 (240V) was 086407		
48	Grommet	074820	27	Truss Hd Screw 8-32 x 1/2	005764	NS - Not shown on page 14		

# Electrical Schematic

(Units built before January 1, 1989)

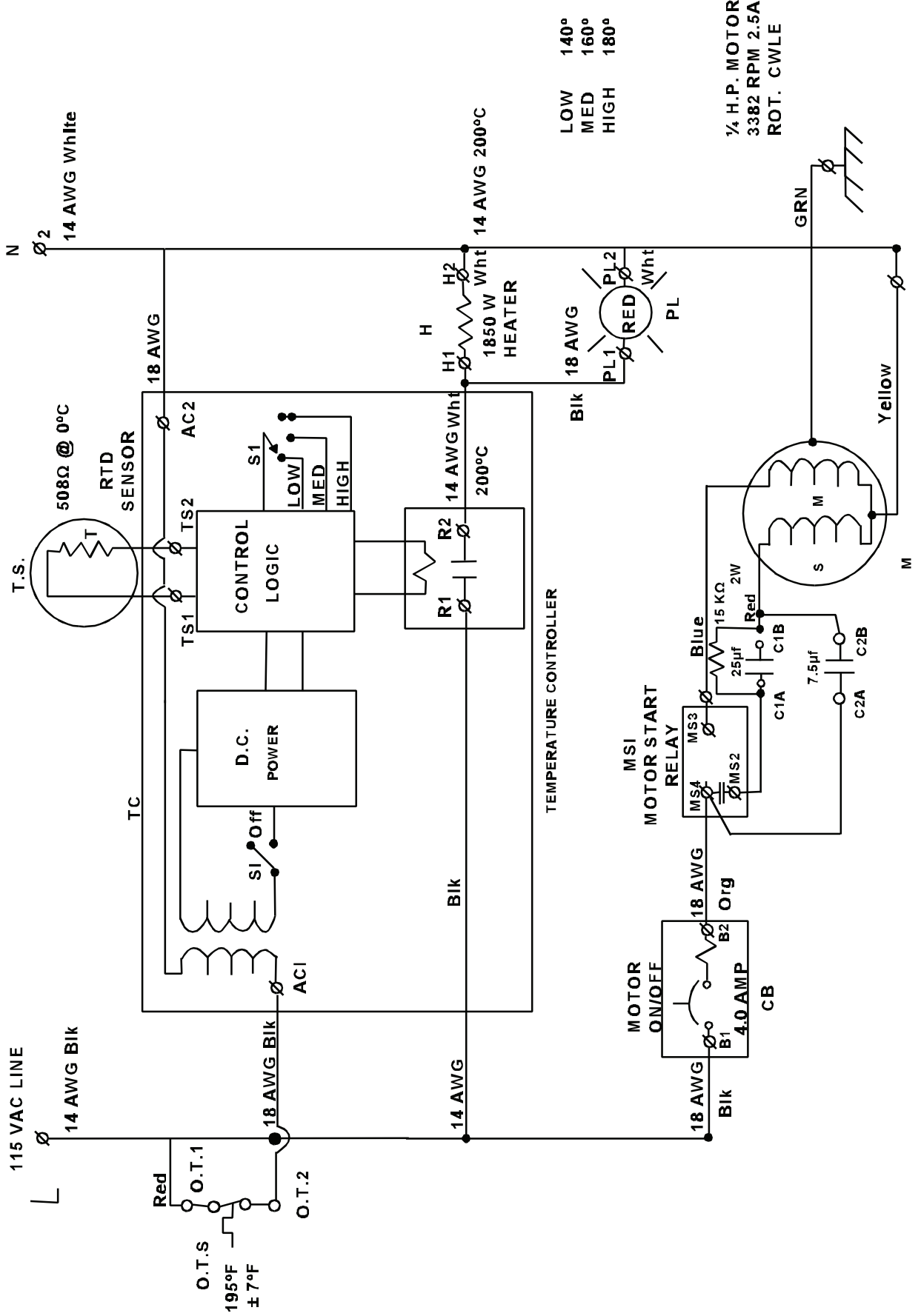



# ELECTRICAL SCHEMATIC FOR

- a) Units built from January 1, 1989 through June 2003 and
- b) Units built after January 1, 2006

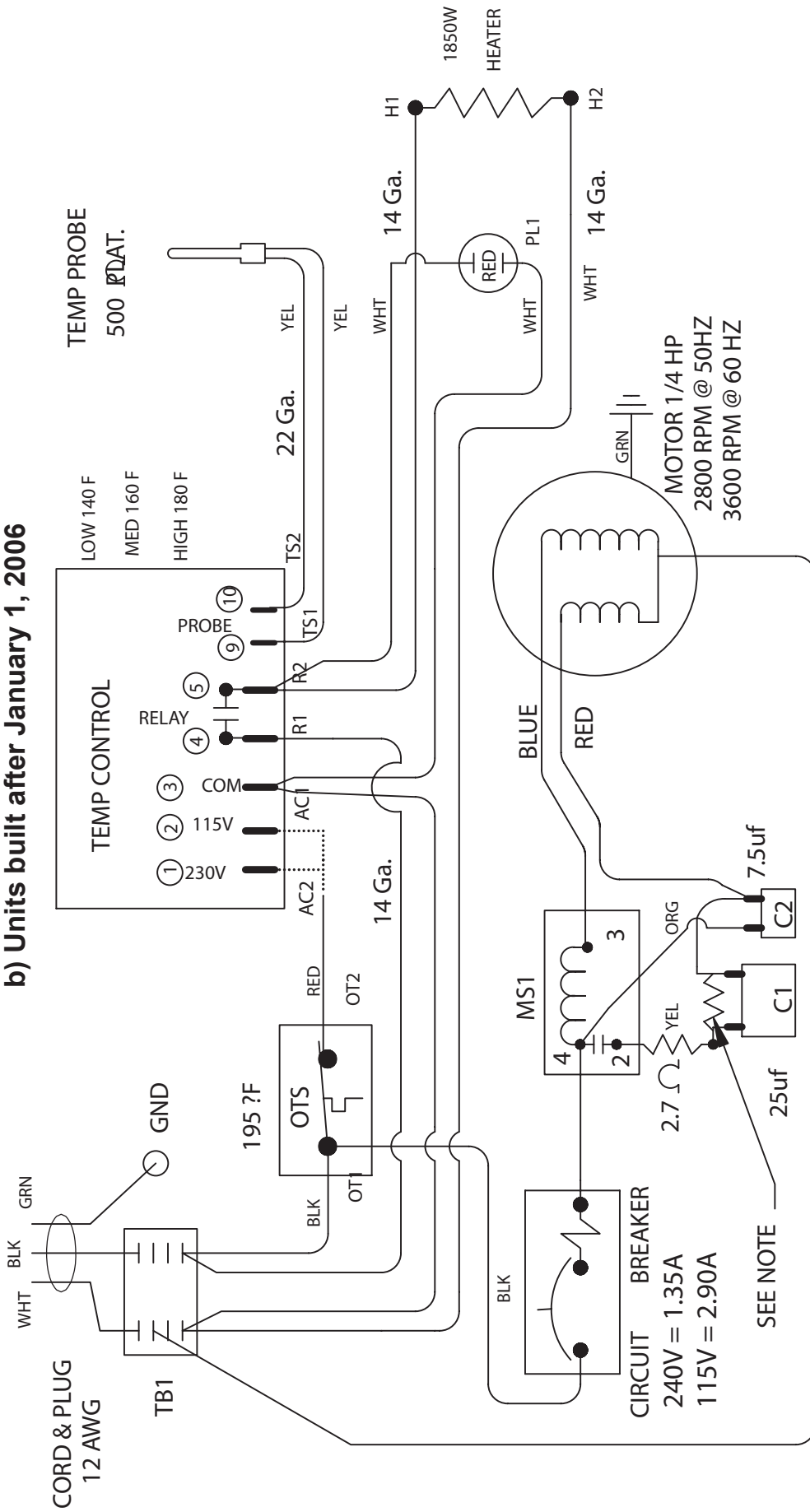

# 086408 REV G

NOTE: MINIMUM 15K RESISTOR MAY BE  
EXTERNAL OR INTERNAL TO CAPACITOR (C1)

ALL WIRES 18 AWG UNLESS NOTED

# ELECTRICAL SCHEMATIC FOR Units built from July 1, 2003 through December 2005

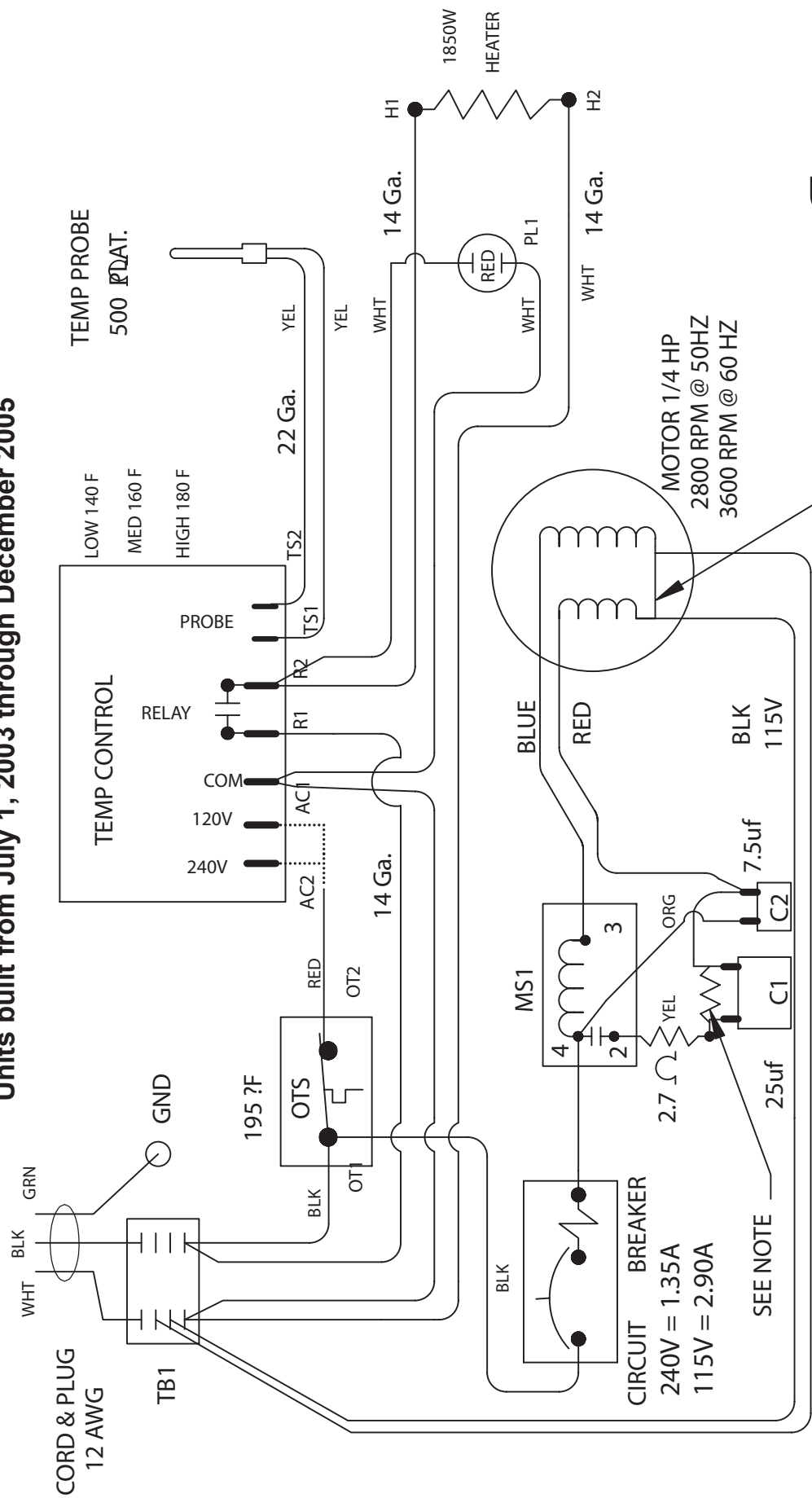

# 086408 REV E

# Service Log

Model No. \_\_\_\_\_ Purchased From \_\_\_\_\_

Serial No. \_\_\_\_\_ Location \_\_\_\_\_

Date Purchased \_\_\_\_\_ Date Installed \_\_\_\_\_

Purchase Order No. \_\_\_\_\_ For Service Call \_\_\_\_\_

Date	Maintenance Performed	Performed by

## Service Log

Model No. \_\_\_\_\_ Purchased From \_\_\_\_\_

Serial No. \_\_\_\_\_ Location \_\_\_\_\_

Date Purchased \_\_\_\_\_ Date Installed \_\_\_\_\_

Purchase Order No. \_\_\_\_\_ For Service Call \_\_\_\_\_

Date	Maintenance Performed	Performed by

## Service Log

Model No. \_\_\_\_\_ Purchased From \_\_\_\_\_

Serial No. \_\_\_\_\_ Location \_\_\_\_\_

Date Purchased \_\_\_\_\_ Date Installed \_\_\_\_\_

Purchase Order No. \_\_\_\_\_ For Service Call \_\_\_\_\_

Date	Maintenance Performed	Performed by

## Service Log

Model No. \_\_\_\_\_ Purchased From \_\_\_\_\_  
Serial No. \_\_\_\_\_ Location \_\_\_\_\_  
Date Purchased \_\_\_\_\_ Date Installed \_\_\_\_\_  
Purchase Order No. \_\_\_\_\_ For Service Call \_\_\_\_\_

Date	Maintenance Performed	Performed by

# Limited Warranty To Calico Cottage, Inc.

(Domestic U.S., Hawaii & Canadian Sales ó  
Parts Only are warranted elsewhere)

Groen Foodservice Equipment ("Groen Equipment") has been skillfully manufactured, carefully inspected and packaged to meet rigid standards of excellence. Groen warrants TDB/8-20-CFC kettles sold to Calico Cottage, Inc. to be free from defects in material and workmanship for (12) twelve months, and the parts thereof to be free from defects for thirty-six (36) months, with the following conditions and subject to the following limitations.

- I. This parts and labor warranty is limited to Groen TDB/8-20-CFC kettles sold to Calico Cottage, Inc., in the continental United States, Hawaii and Canada.
- II. Damage during shipment is to be reported to the carrier, is not covered under this warranty, and is the sole responsibility of purchaser/user.
- III. Groen, or an authorized service representative, will repair or replace, at Groen's sole election, any Groen Equipment, including but not limited to, valves, electric components, and motors, found to be defective during the warranty period. As to warranty service in the territory described above, Groen will absorb labor and portal to portal transportation costs (time & mileage) for the first twelve (12) months from date of installation or fifteen (15) months from date of shipment from Groen. For TDB/8-20-CFC equipment sold to Calico Cottage, Inc., furthermore, Groen will absorb the cost of replacement parts for a period of thirty-six (36) months from the date of shipment. This replacement parts warranty applies to all locations, world-wide.
- IV. This warranty does not cover routine maintenance, calibration, periodic adjustments as specified in operating instructions or manuals, and consumable parts such as scraper blades, gaskets, packing, etc., or labor costs incurred for removal of adjacent equipment or objects to gain access to Groen Equipment. This warranty does not cover defects caused by improper installation, abuse, careless operation, or improper maintenance of equipment. This warranty does not cover damage caused by poor water quality or improper maintenance.
- V. THIS WARRANTY IS EXCLUSIVE AND IS IN LIEU OF ALL OTHER WARRANTIES, EXPRESSED OR IMPLIED, INCLUDING ANY IMPLIED WARRANTY OF MERCHANTABILITY OR FITNESS FOR A PARTICULAR PURPOSE, EACH OF WHICH IS HEREBY EXPRESSLY DISCLAIMED. THE REMEDIES DESCRIBED ABOVE ARE EXCLUSIVE AND IN NO EVENT SHALL GROEN BE LIABLE FOR SPECIAL, CONSEQUENTIAL OR INCIDENTAL DAMAGES FOR THE BREACH OR DELAY IN PERFORMANCE OF THIS WARRANTY.
- VI. Groen Equipment is for commercial use only. If sold as a component of another (O.E.M.) manufacturer's equipment, or if used as a consumer product, such Equipment is sold AS IS and without any warranty.



**CALICO COTTAGE, INC.**



1055 Mendell Davis Drive • Jackson MS 39272  
888-994-7636 • 601-372-3903 • Fax 888-864-7636  
groen.com

