NO. 80VC-782

ISSUED: OCT. 20, 2009

REVISED: MAR. 11, 2010



**HOSHIZAKI
DISHWASHER**

MODEL JWE-620UA-6B

SERVICE MANUAL

IMPORTANT

Only qualified service technicians should install, service, and maintain the unit. No service or maintenance should be undertaken until the technician has thoroughly read this Service Manual. Failure to service and maintain the equipment in accordance with this manual may adversely affect safety, performance, component life, and warranty coverage.

Hoshizaki provides this manual primarily to assist qualified service technicians in the maintenance and service of the unit.

Should the reader have any questions or concerns which have not been satisfactorily addressed, please call, write, or send an e-mail message to the Hoshizaki Technical Support Department for assistance.

HOSHIZAKI AMERICA, INC.
618 Highway 74 South
Peachtree City, GA 30269

Attn: Hoshizaki Technical Support Department

Phone: 1-800-233-1940 Technical Support
(770) 487-2331

Fax: 1-800-843-1056
(770) 487-3360

E-mail: techsupport@hoshizaki.com

Web Site: www.hoshizaki.com

NOTE: To expedite assistance, all correspondence/communication MUST include the following information:

- Model Number _____
- Serial Number _____
- Complete and detailed explanation of the problem.

IMPORTANT

This manual should be read carefully before the unit is serviced or maintenance operations are performed. Only qualified service technicians should install, service, and maintain the unit. Read the warnings contained in this booklet carefully as they give important information regarding safety. Please retain this booklet for any further reference that may be necessary.

CONTENTS

I. Specifications	1
A. Specification Sheet	1
B. Nameplate Rating	2
C. Dimensions/Connections	3
II. General Information	4
A. Construction	4
1. Dishwasher	4
2. Internal Booster Tank	5
3. Control Box	6
B. Sequence of Operation	7
1. Auto Fill Cycle	7
2. Ready Cycle (Unit Inactive)	7
3. Wash Cycle	8
4. Rinse Cycle	9
5. Drain	10
C. Sequence of Operation Flow Chart	11
D. Control Board and Operation Board	12
1. Control Board Location	12
2. Control Board Layout	13
3. Control Board Diagram	14
4. Operation Panel Layout	15
5. Features	15
6. Controls, Adjustments, and Lamps	15
7. Service Menu and Error Log	16
8. Temperature Display	18
9. Error Codes	18
10. Buzzer	18
11. Special Modes	19
III. Service Diagnosis	20
A. Diagnostic Procedure	20
B. Error Codes	22
1. Error Code Table	22
2. Error Code Log	23
3. Error Code Details	24
C. Service Flow Charts	33
1. Unit Will Not Start	33
2. Dishes Not Clean	35

3. Inadequate Rinse -----	37
4. Dishwasher Will Not Start When Door Closed -----	38
5. No or Inadequate Detergent/Rinse Aid Supply -----	39
6. Wash Tank Water Boils -----	39
7. Wash Tank Water Not Draining -----	40
D. Float Switch Check and Cleaning -----	41
1. Float Switch Check -----	41
2. Float Switch Cleaning -----	41
E. Thermistor Check -----	42
IV. Removal and Replacement of Components -----	43
A. Removal of Panels -----	43
B. Accessing the Control Box -----	43
C. Removal and Replacement of Internal Booster Tank -----	45
D. Removal and Replacement of Wash Pump Motor -----	46
E. Removal and Replacement of Rinse Pump Motor -----	47
F. Removal and Replacement of Handle -----	48
G. Removal and Replacement of Door -----	49
H. Removal and Replacement of Spring Unit -----	50
I. Removal and Replacement of Spring -----	50
J. Adjustment of Door Opening/Closing Force -----	51
K. Removal and Replacement of Flush Pipe -----	52
L. U-Packing Installation Instructions -----	53
M. Removal and Replacement of Thermistor -----	54
N. Removal and Replacement of Control Board or Operation Board -----	55
1. Control Board -----	55
2. Operation Board -----	55
V. Cleaning and Maintenance Instructions -----	57
A. Daily Maintenance -----	57
B. Self-Cleaning -----	59
C. Weekly Maintenance -----	60
1. Heater -----	60
2. Exterior -----	60
3. Wash Compartment -----	60
D. Monthly Maintenance -----	60
1. Power Switch (Ground Fault Circuit Interrupter) -----	60
2. Water Supply Line -----	60
E. Descaling (As Required) -----	61
F. Shutdown -----	62
G. Long Storage, Relocation, Disposal, Transfer -----	63
VI. Operating Instructions -----	64
VII. Technical Information -----	65
A. Water Circuit -----	65
B. Wiring Diagram -----	66

Important Safety Information

Throughout this manual, notices appear to bring your attention to situations which could result in death, serious injury, or damage to the unit.

⚠ WARNING Indicates a hazardous situation which could result in death or serious injury.

CAUTION Indicates a situation which could result in damage to the unit.

IMPORTANT Indicates important information about the use and care of the unit.

⚠ WARNING

This product should be destined only to the use for which it has been expressly conceived. Any other use should be considered improper and therefore dangerous. The manufacturer cannot be held responsible for eventual damage caused by improper, incorrect, and unreasonable use.

To reduce the risk of death, electric shock, serious injury, or fire, follow basic precautions including the following:

- Electrical connection must be hard-wired and must meet national, state, and local electrical code requirements. Failure to meet these code requirements could result in death, electric shock, serious injury, fire, or severe damage to equipment.
- This unit requires an independent power supply. See the nameplate for proper voltage and breaker/fuse size. Failure to use a proper breaker or fuse can result in a tripped breaker, blown fuse, or damage to existing wiring. This could lead to heat generation or fire.
- **THIS UNIT MUST BE GROUNDED.** Failure to properly ground this unit could result in death or serious injury.
- This unit should be disassembled or repaired only by qualified service personnel to reduce the risk of electric shock, injury, or fire.
- Do not make any alterations to the unit. Alterations could result in electric shock, injury, fire, or damage to the unit.
- To avoid possible burns and spills, be sure to drain the wash tank and internal booster tank and let the components cool before servicing. When draining the internal booster tank, wait until the water temperature falls below 104°F (40°C).
- When disassembling components that have been in contact with detergent, wear rubber gloves and goggles. Before starting disassembly, thoroughly read the detergent safety instructions. Contact with skin may cause irritation and contact with eyes may cause blindness.
- When using an acidic descaling cleaner, wear rubber gloves and goggles. Contact with skin may cause irritation, and contact with eyes may cause blindness. Do not use or mix with a dishwashing detergent. Some detergents may generate toxic chlorine gas.

I. Specifications

A. Specification Sheet

		WASH TANK SIDE	BOOSTER TANK SIDE
AC SUPPLY VOLTAGE		3 phase 3-wire 208-230V/60Hz (±10%)	
POWER SUPPLY CAPACITY		15.8kVA(39.7A)	
AMPERAGE		Max Running 36.6A, Rated Motor 4.2A	
STARTING AMPERAGE		26.0A	
ELECTRICAL CONSUMPTION		Rated Motor 1.40kW (Power Factor 85%) Max 14.30kW	
HEATER		6.9kW	6.0kW
RACK SIZE		19-3/4" × 19-3/4"(500 × 500mm)	
NUMBER OF LARGE DISHES / RACK		16 plates (9.1" DIA)	
CYCLE TIME		53 sec (wash 41 sec, dwell 5 sec, rinse 6 sec, dwell 1 sec)	
WATER CONSUMPTION		0.53Gal/cycle(2.0L/cycle)	
OUTSIDE DIMENSIONS		W25.2" × D25.8" × H60.5" (W640 × D655 × H1,537mm)	
EXTERIOR		Stainless Steel	
DOOR		Vertical Sliding Door (opening height 18.0") (457mm)	
WASH SYSTEM		Upper and Lower Triple Spray Arms (common arms on top and bottom)	
RINSE SYSTEM		Upper and Lower Wide Angle Spray Arms	
PUMP		Wash 1HP, Rinse 0.134HP	
DRAIN SYSTEM		Draw Out Overflow Pipe, Overflow Drain	
START		Door Switch (start switch mode also available)	
DRY SYSTEM		Residual Heat Drying	
REFUSE DISPOSAL		Filter Collection	
DETERGENT		Not Provided	
DISPLAY		Ready, Auto Fill, Rinse, Wash-Standard, Wash-Long, Pause Wash Water Temperature, Rinse Water Temperature, Error	
TANK CAPACITY		14.3Gal (54L)	1.9Gal (7.3L)
HOT WATER SUPPLY		Automatic Hot Water Supply by Microprocessor Control	Automatic Hot Water Supply by Water Valve
TEMPERATURE CONTROL		Wash: 150°F(66°C) min. Thermistor Control: 163°F(73°F) - 168(76°F)	Rinse: 180°F(82°C) min. Thermistor Control: 182°F(83°C)-185°F (85°C)
CONNECTION – WATER SUPPLY – DRAIN		Inlet: 3/4"FPT Outlet: 1-1/2"MPT	
CONTROL	WASH TIME	Standard: 1 - 99 sec, in 1 sec steps	
	RINSE TIME	Long: 10 - 990 sec, in 10 sec steps	
	END BUZZER VOLUME	5 - 12 sec, Adjustable, in 1 sec steps 0 - Max, Adjustable	
ELECTRIC CIRCUIT PROTECTION		Ground Fault Circuit Interrupter (with Overcurrent Protector)	
BOIL – DRY PROTECTION		Water Level Switch, Bimetal Thermostat (Manual - Reset), Thermistor (Auto - Reset)	Float Switch, Bimetal Thermostat (Manual - Reset), Thermistor (Auto - Reset)
SAFETY SYSTEM		Door Switch, Emergency Stop by Microprocessor Control	
WEIGHT		Net 247lb (112kg) / Gross 344lb (156kg)	
PACKAGE		Carton + Crate W32.1"×D34.6"×H68.0" (815mm × 880mm × 1,726mm)	
CERTIFICATION		NSF ANSI-3, ETL, Energy Star	
ACCESSORIES		Universal rack (19-3/4" x 19-3/4") x 1, Instruction manual x 1 Installation manual x 1, Maintenance sheet (English and Spanish)x 1 Inlet water strainer & Packing x 1,	
OPERATION CONDITIONS		Ambient Temperature: 41 - 95°F (5°C - 35°C) Voltage Range: Rated Voltage ±10% Recommends Water Hardness : 4gpg (grains per gallon) (68.5ppm) or less Water Supply Temperature: 110 - 167°F (43°C - 75°C) (Recommends 140 °F (60°C)) Water Supply Pressure (Gauge Static Pressure): 10 - 70PSIG (0.07 - 0.48 MPa)	
* The rated properties are based on measurements at ambient temperature of 86°F (30°C) according to the Technical Requirements for Electrical Appliances.			
* We reserve the right to make changes in specifications and design without prior to notice.			

B. Nameplate Rating

HOSHIZAKI DISHWASHER	
MODEL NUMBER	JWE-620UA-6B
SERIAL NUMBER	
AC SUPPLY VOLTAGE	208-230V/60Hz/3PH
CAPACITY	15.8kVA (39.7A)
TOTAL	14.3kW (36.6A)
WASH PUMP	AC230V 4.2AMPS 1HP
RINSE PUMP	AC230V 0.7AMPS 0.13HP
WASH HEATER	AC230V 2.3kW × 3
RINSE HEATER	AC230V 2kW × 3

HOSHIZAKI ELECTRIC CO., LTD.
MADE IN SHIMANE, JAPAN

 **CONFORMS TO**
UL STD .921
CERTIFIED TO
CSA-C22.2
NO.168

3168669

We reserve the right to make changes in specifications and design without prior notice.

II. General Information

A. Construction

1. Dishwasher

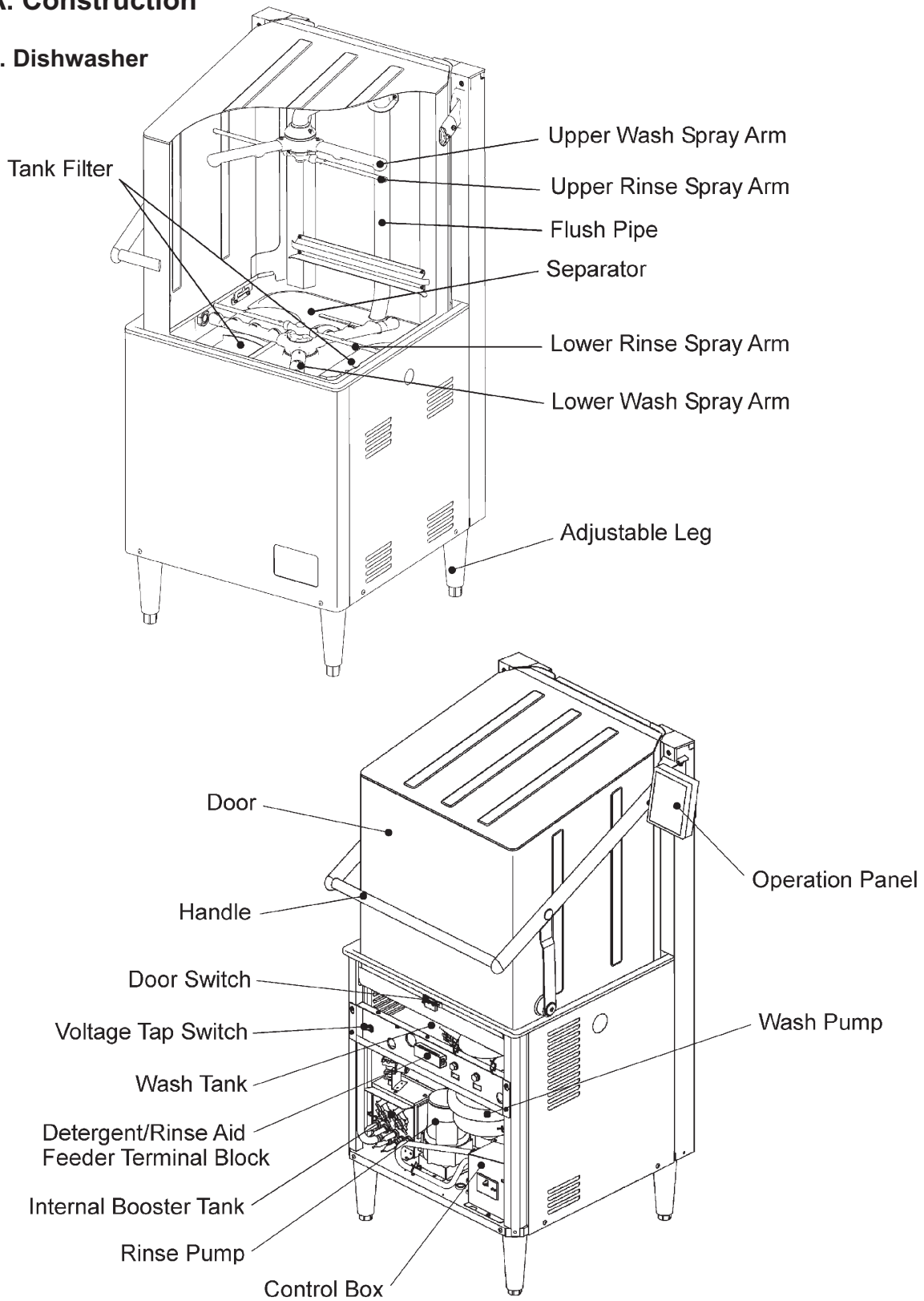

2. Internal Booster Tank

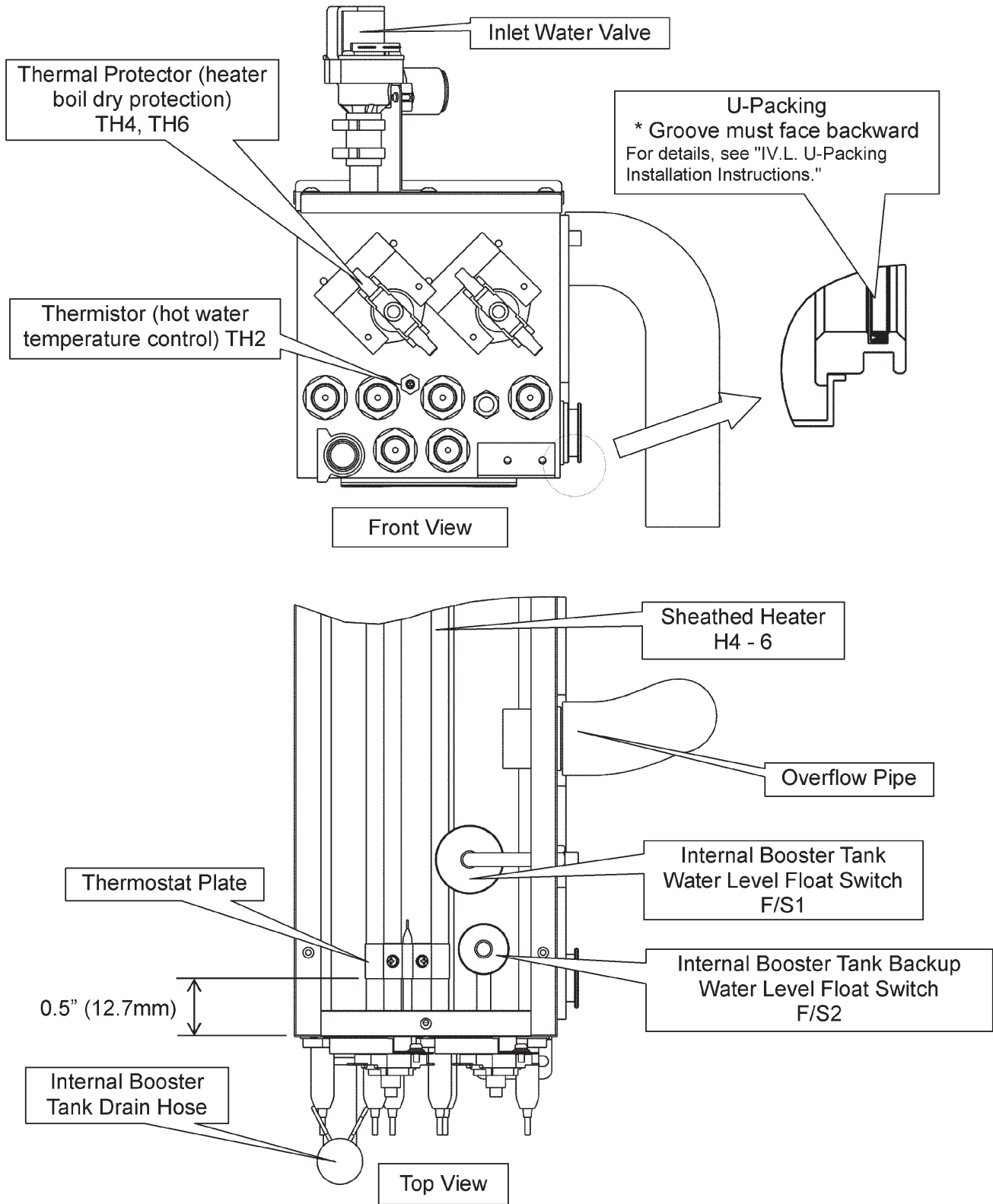

Legend: **F/S**—float switch; **H**—heater; **TH**—thermistor

3. Control Box

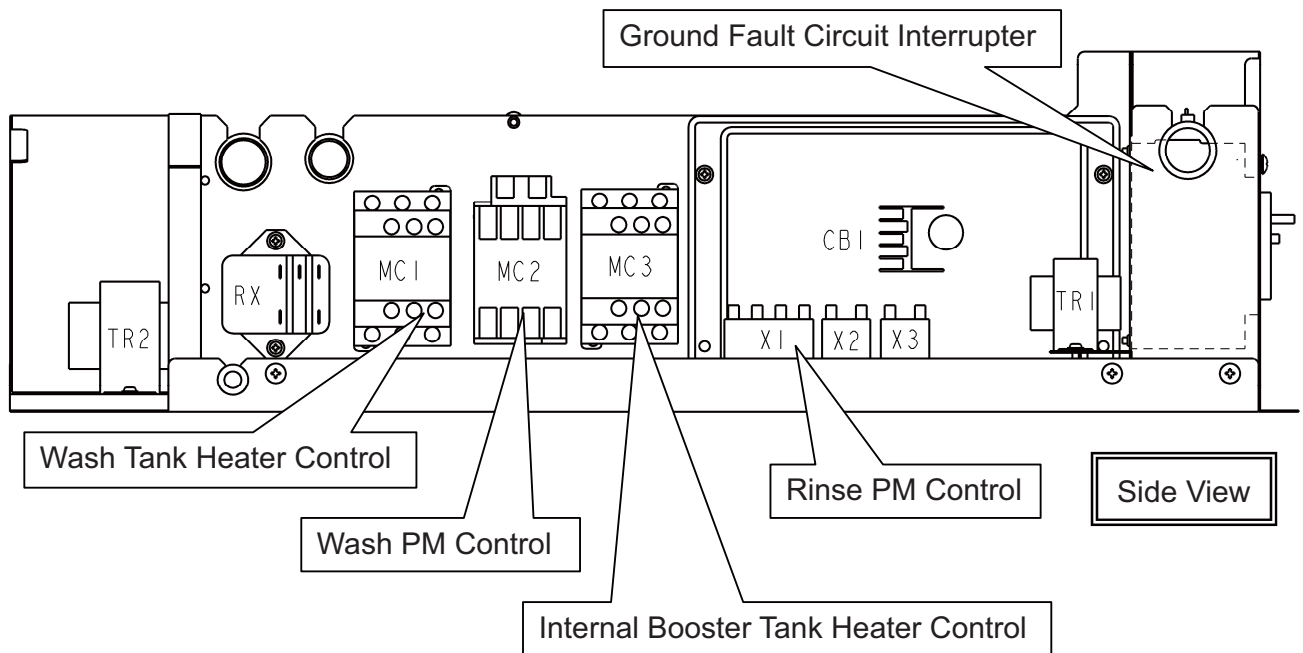
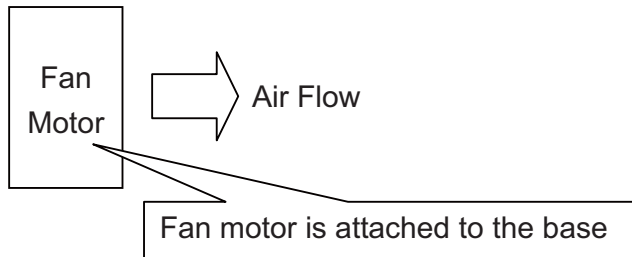
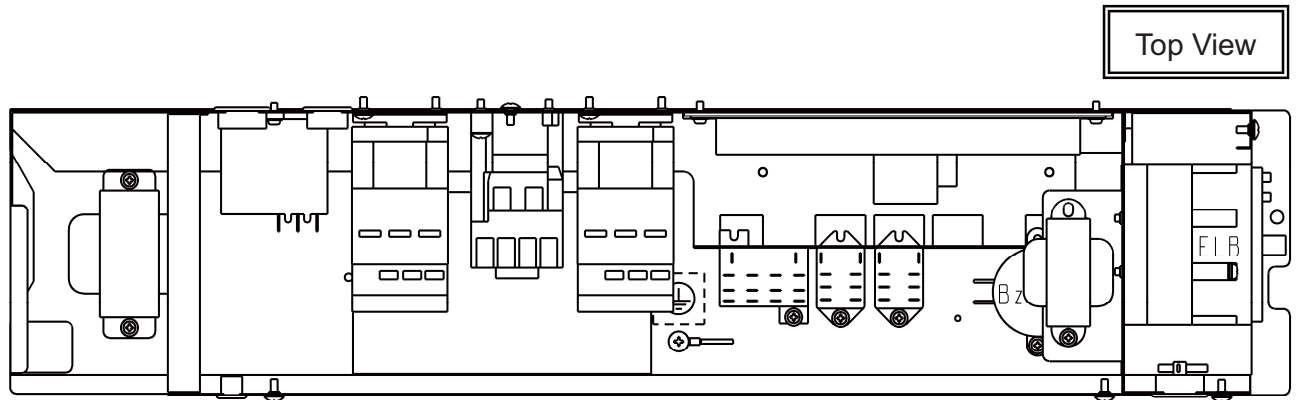

Legend: **CB**—control board; **GFCI**—ground fault circuit interrupter; **MC**—magnetic contactor; **PM**—pump motor; **RX**—phase reversal relay; **TR**—transformer; **X**—relay

B. Sequence of Operation

The steps in the sequence are as outlined below.

1. Auto Fill Cycle

"AUTO FILL" lamp flashing and "RINSE," "STANDARD," or "LONG" lamp on.

If WT WLS is open when power is supplied and the "ON/OFF" button is pressed, the "AUTO FILL" lamp flashes and the auto fill cycle starts.

WV energizes. When BT WLF/S closes, WV de-energizes, RPM energizes and power is supplied to RFT. RPM energizes and power is supplied to RFT for length of time set by the rinse cycle time setting. For details, see "Rinse Cycle Time" (service menu item 03) in "II.D.7.b) Service Menu Chart." RPM then de-energizes for 10 seconds and power is cut to RFT for 10 seconds. RPM energizes/de-energizes (and power is supplied to and cut to RFT) the number of times set by the auto fill cycle setting. For details, see "Auto Fill Cycle" (service menu item 07) in "II.D.7.b) Service Menu Chart." During the auto fill cycle, BT WLF/S opens/closes to energize/de-energize WV.

At the end of the auto fill cycle, there is a 5-second dwell time. CB checks WT WLS. If WT WLS is closed, BZ beeps, the "AUTO FILL" lamp goes off and the "READY" lamp comes on. If WT WLS is open, BZ beeps continuously, the "AUTO FILL" lamp goes off and "A1" flashes in the display. For details, see "III.B.3.a) Auto Fill Error (A1)."

Note:

1. If DS opens during the auto fill cycle, the "AUTO FILL" lamp goes off, RPM de-energizes, and power is cut to RFT. When DS closes again, the "AUTO FILL" lamp starts flashing and the unit resumes cycling RPM and power to RFT for the remaining number of times determined by the auto fill cycle setting.
2. BTH and WTH are de-energized during the auto fill cycle.
3. If BT WLF/S fails, BT BUWLF/S assumes control. If BT BUWLF/S remains closed for 1 minute, o1 or o2 error appears in the display. For details, see "III.B. Error Codes."
4. "STANDBY/CLEANING" button is inactive during the auto fill cycle.

2. Ready Cycle (Unit Inactive)

"READY" lamp and "RINSE," "STANDARD," or "LONG" lamp on.

WT WLS closed. After a rinse cycle, RPM de-energizes and power is cut to RFT.

WTH energizes when WT water temperature is at the wash temperature setpoint or lower. For details, see "Wash Temperature Setpoint" (service menu item 04) in "II.D.7.b) Service Menu Chart." WTH de-energizes when WT water temperature is 5°F (3°C) above the setpoint. BTH energizes when BT water temperature is 3°F (2°C) below the rinse temperature setpoint or lower. For details, see "Rinse Temperature Setpoint" (service menu item 05) in "II.D.7.b) Service Menu Chart." BTH de-energizes when BT water temperature reaches the setpoint. WV energizes/de-energizes when BT WLF/S opens/closes.

Note: To prevent the wash or rinse cycle from starting when the door is closed (if service menu item 11 is set for door start), press the "STANDBY/CLEANING" button. The "READY" lamp goes off and the "STANDBY/CLEANING" lamp comes on. Press

the "STANDBY/CLEANING" button again to return to "READY." For details on start initiation, see "Wash/Rinse Cycle Start Initiation" (service menu item 11) in "II.D.7.b) Service Menu Chart."

3. Wash Cycle

The wash cycle can be started by either the door switch or the "STANDBY/CLEANING" button. For details, see "Wash/Rinse Cycle Start Initiation" (service menu item 11) in "II.D.7.b) Service Menu Chart."

Door Switch Start

When the "READY" lamp is on, the unit starts operation in the selected mode when DS closes.

Note: If the "STANDBY/CLEANING" button is pressed when the "READY" lamp is on, the "READY" lamp goes off and the "STANDBY" lamp comes on. When the "STANDBY" lamp is on, the unit will not operate even if DS closes. To cancel standby, press the "STANDBY/CLEANING" button.

"STANDBY/CLEANING" Button Start

When the "READY" lamp is on, the unit starts operation in the selected mode when the "STANDBY/CLEANING" button is pressed.

"STANDARD" or "LONG" lamp flashing (depending on the wash mode selected).

WPM energizes and power is supplied to DFT for the length of time set by the wash cycle time setting. For details, see "Wash Cycle Time (Standard Mode) or "Wash Cycle Time (Long Mode)" (service menu item 01 or 02) in "II.D.7.b) Service Menu Chart."

WPM draws water from WT and sends it through the wash spray arms. When the wash cycle time has expired, CB checks BT WLF/S. If BT WLF/S is open, the wash cycle is extended and the lights in the display rotate. If BT WLF/S is closed, the unit enters a 5-second dwell time and then proceeds to the rinse cycle. If BT WLF/S does not close within 10 minutes after the auto fill cycle starts, "A2" appears in the display, and the unit shuts down. During the 5-second dwell time, detergent containing wash water on the door liner and inside the wash spray arms flows back into WT.

During the wash cycle, WTH energizes when WT water temperature is at the wash temperature setpoint or lower. For details, see "Wash Temperature Setpoint" (service menu item 04) in "II.D.7.b) Service Menu Chart." WTH de-energizes when WT water temperature is 5°F (3°C) above the setpoint. BTH energizes when BT water temperature is 3°F (2°C) below the rinse temperature setpoint or lower. For details, see "Rinse Temperature Setpoint" (service menu item 05) in "II.D.7.b) Service Menu Chart."

BTH de-energizes when BT water temperature reaches the setpoint. WV energizes/de-energizes when BT WLF/S opens/closes.

Note: If DS opens during the wash cycle, BZ beeps, the "STANDARD" or "LONG" lamp goes off, the "READY" lamp comes on, WPM de-energizes and power is cut to DFT. When DS closes again (if service menu item 11 is set for door start), the "STANDARD" or "LONG" lamp starts flashing and the unit starts a new wash cycle.

4. Rinse Cycle

The rinse cycle starts automatically after the wash cycle. When the mode is set to "RINSE," the rinse cycle can also be started by either the door switch or the "STANDBY/CLEANING" button. For details, see "Wash/Rinse Cycle Start Initiation" (service menu item 11) in "II.D.7.b) Service Menu Chart."

Door Switch Start

When the "READY" lamp is on, the unit starts operation in the selected mode when DS closes.

Note: If the "STANDBY/CLEANING" button is pressed when the "READY" lamp is on, the "READY" lamp goes off and the "STANDBY" lamp comes on. When the "STANDBY" lamp is on, the unit will not operate even if DS closes. To cancel standby, press the "STANDBY/CLEANING" button.

"STANDBY/CLEANING" Button Start

When the "READY" lamp is on, the unit starts operation in the selected mode when the "STANDBY/CLEANING" button is pressed.

"RINSE" lamp flashing.

RPM energizes and power is supplied to RFT for length of time set by the rinse cycle time setting. For details, see "Rinse Cycle Time" (service menu item 03) in "II.D.7.b) Service Menu Chart." RPM draws water from BT and sends it through the rinse spray arms. Rinse aid is fed into the rinse water line and sprayed from the rinse spray arms together with rinse water. Any excess water in WT drains through the overflow pipe. After RPM de-energizes, the unit enters a 1-second dwell time. After the dwell time, CB checks BT WLF/S. If BT WLF/S is open, the lights in the display rotate until BT WLF/S closes. If BT WLF/S is closed, BZ beeps for 2 seconds, the "READY" lamp comes on, and the unit returns to the ready cycle. If BT WLF/S does not close within 10 minutes after the auto fill cycle starts, "A2" appears in the display, and the unit shuts down. During the 1-second dwell time, hot rinse water on the door liner and inside the rinse spray arms flows back into WT. The "RINSE" lamp keeps flashing.

During the rinse cycle, WTH energizes when WT water temperature is at the wash temperature setpoint or lower. For details, see "Wash Temperature Setpoint" (service menu item 04) in "II.D.7.b) Service Menu Chart." WTH de-energizes when WT water temperature is 5°F (3°C) above the setpoint. BTH energizes when BT water temperature is 3°F (2°C) below the rinse temperature setpoint or lower. For details, see "Rinse Temperature Setpoint" (service menu item 05) in "II.D.7.b) Service Menu Chart."

BTH de-energizes when BT water temperature reaches the setpoint. WV energizes/de-energizes when BT WLF/S opens/closes.

Note: If DS opens during the rinse cycle, BZ beeps, the "RINSE" lamp goes off, the "READY" lamp comes on, RPM de-energizes, and power is cut to RFT. When DS closes again (if service menu item 11 is set for door start), the unit starts a new cycle in the selected mode.

5. Drain

This unit does not have a drain valve.

The overflow pipe in WT drains excess water from WT. To completely drain WT, remove the overflow pipe.

To drain BT, first move the power switch (GFCI) to the "OFF" position. Turn off the power supply. Lockout/Tagout to prevent the power from being turned back on inadvertently.

Use BT drain hose to drain BT. **WARNING! To avoid possible burns, allow BT water temperature to fall below 104°F (40°C) before draining.**

Legend: **BT**–internal booster tank; **BTH**–internal booster tank heater; **BUWLF/S**–backup water level float switch; **BZ**–buzzer; **CB**–control board; **DFT**–detergent feeder terminals (detergent feeder not provided by Hoshizaki); **DS**–door switch; **RFT**–rinse aid feeder terminals (rinse aid feeder not provided by Hoshizaki); **RPM**–rinse pump motor; **WLF/S**–water level float switch; **WLS**–water level sensor; **WPM**–wash pump motor; **WT**–wash tank; **WTH**–wash tank heater; **WV**–inlet water valve

C. Sequence of Operation Flow Chart

Dishwasher Sequence Flow Chart JWE-620UA-6B

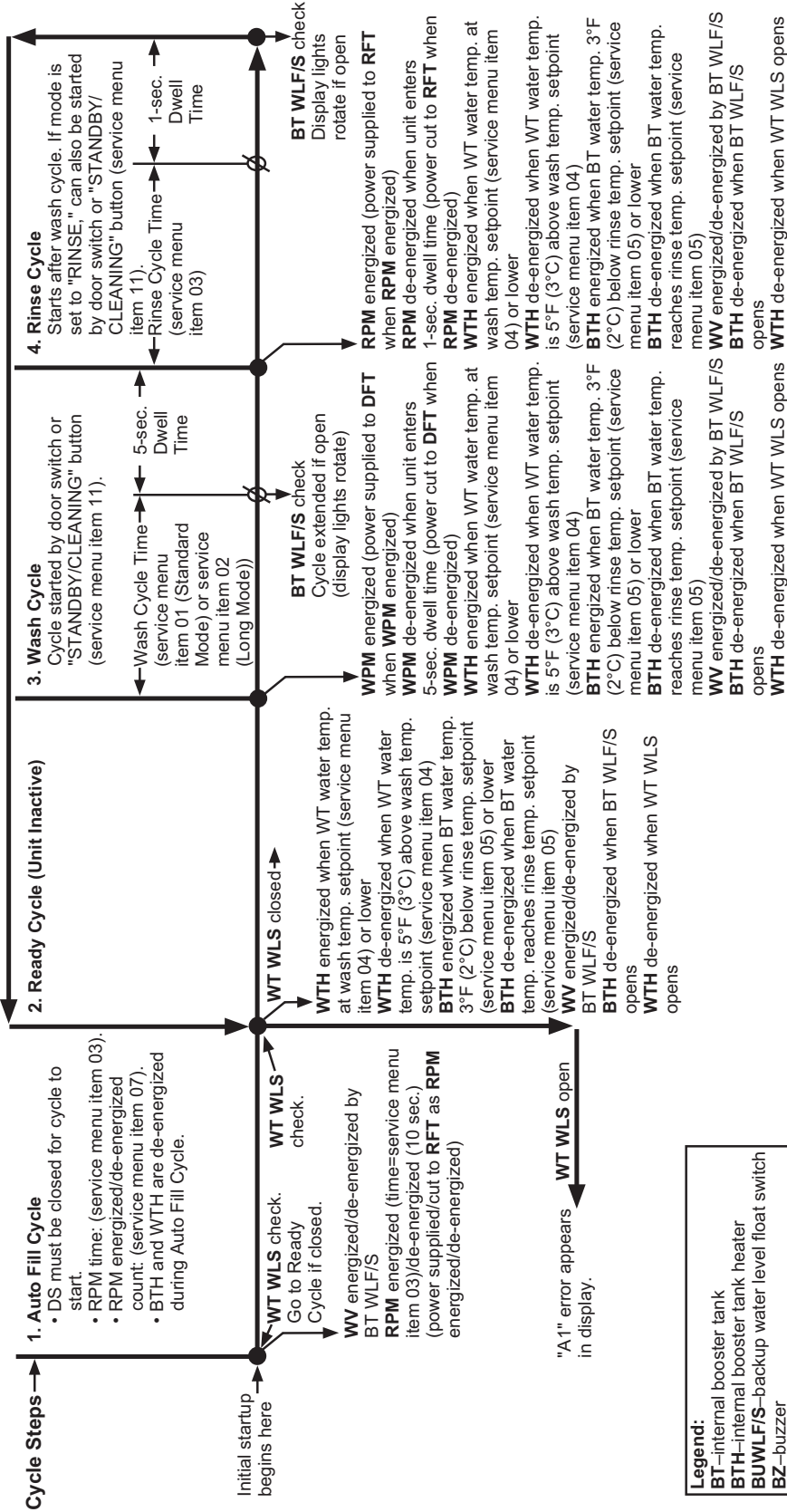

Note: If DS opens during the auto fill, wash, or rinse cycle, BZ beeps, the corresponding cycle lamp goes off and RPM or WPM de-energize. If DS opens during wash or rinse cycle, "READY" lamp comes on. When DS closes again (if service menu item 11 is set for door start), the mode lamp starts flashing. If in auto fill cycle, the unit resumes cycling RPM for the remaining number of times determined by the auto fill cycle setting. If the unit was in a wash or rinse cycle, the unit starts a new cycle in the selected mode.

Legend:

BT—internal booster tank
 BTH—internal booster tank heater
 BUWLF/S—backup water level float switch
 BZ—buzzer
 CB—control board
 DS—detergent feeder terminals
 DS—door switch
 RFT—rinse aid feeder terminals
 RPM—rinse pump motor
 WLF/S—water level float switch
 WLS—water level sensor
 WPM—wash pump motor
 WT—wash tank
 WTH—wash tank heater
 WV—inlet water valve

D. Control Board and Operation Board

- A Hoshizaki exclusive solid-state control board and operation board are employed in all Hoshizaki dishwasher units.
- All models are pretested and factory set.

CAUTION

1. The control board and operation board are fragile; handle very carefully.
2. The control board and operation board contain integrated circuits, which are susceptible to failure due to static discharge. It is especially important to touch the metal part of the unit when handling or replacing the control board or operation board.
3. Do not touch the electronic devices on the control board or operation board or the back of the control board or operation board.
4. Do not attempt to repair the control board or operation board.
5. Do not short out power supply to test for voltage.

1. Control Board Location

The control box is located behind the front panel. Follow the instructions and warnings for safe and efficient operation of the unit.

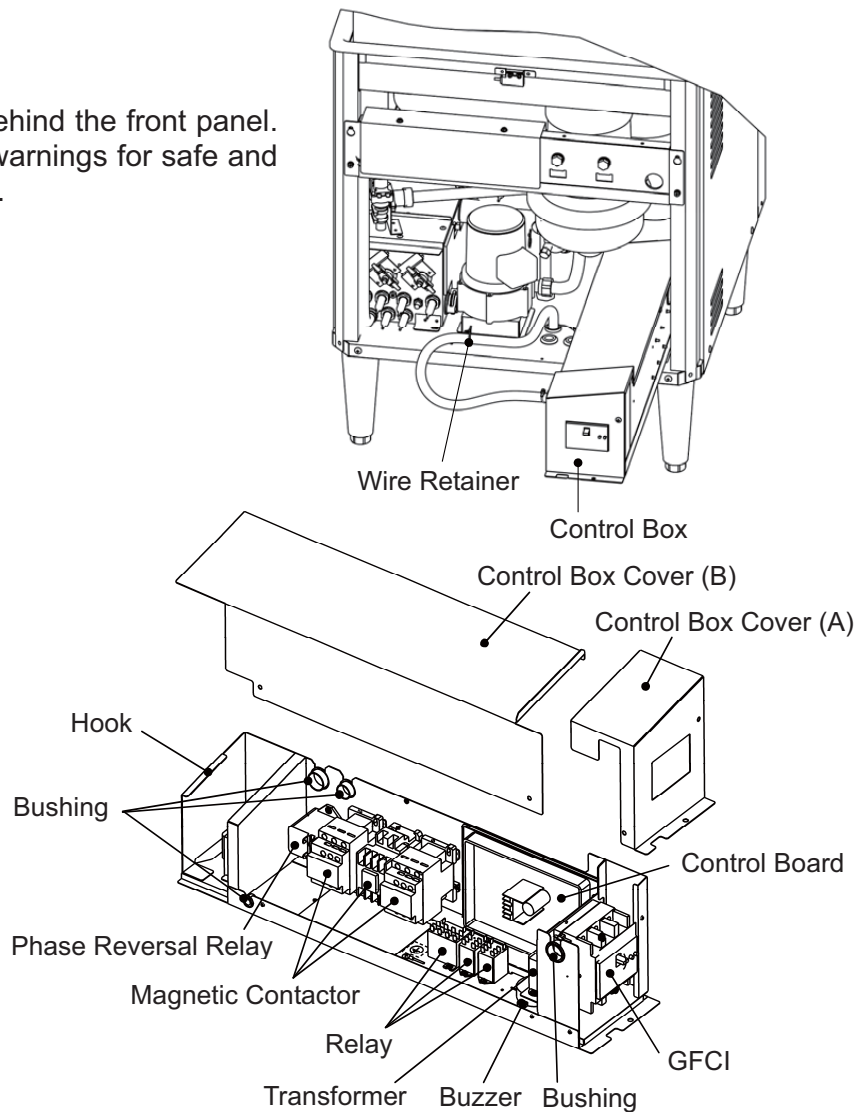

2. Control Board Layout

Inputs and outputs are laid out on the control board as illustrated below.

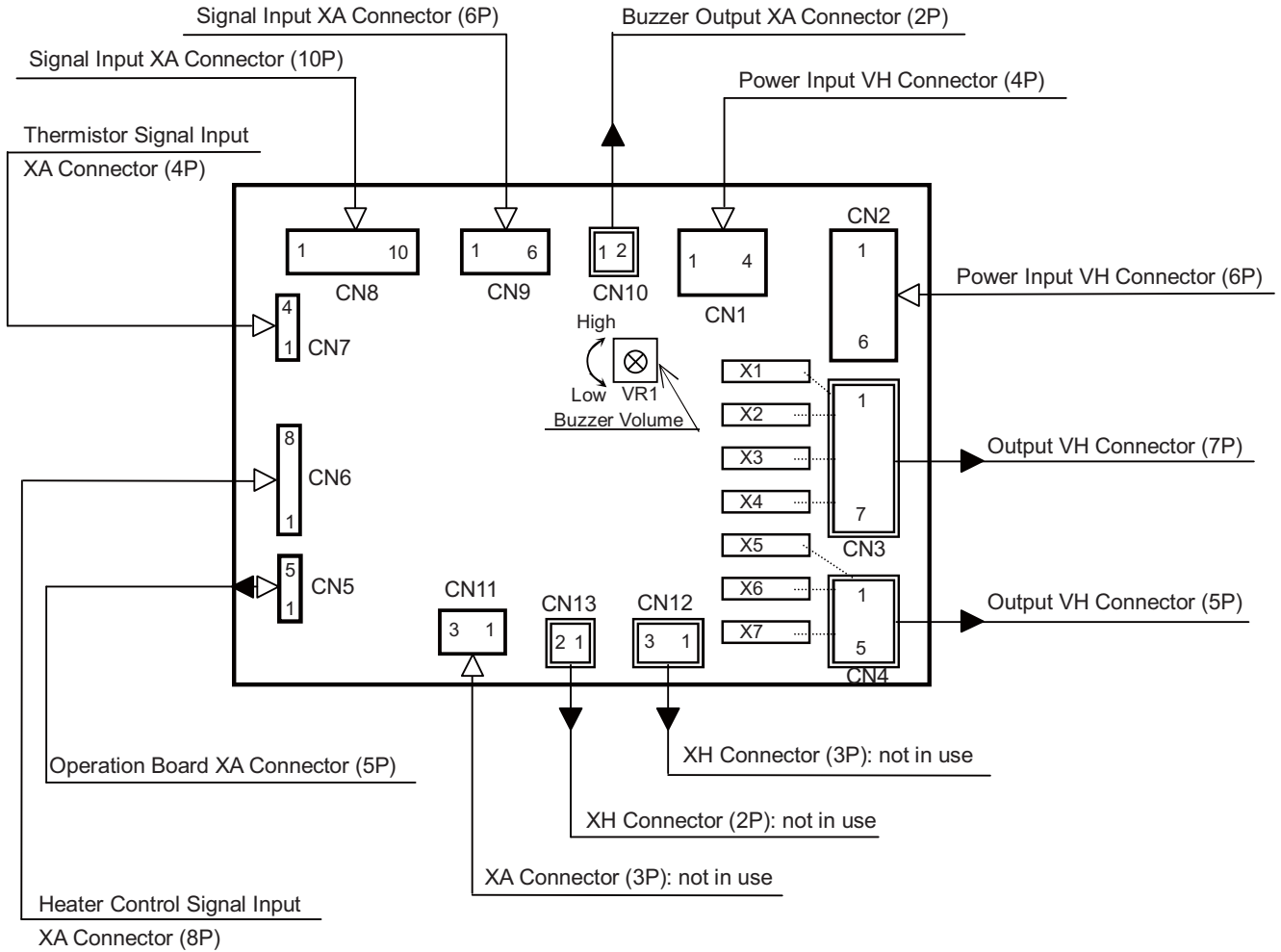

3. Control Board Diagram

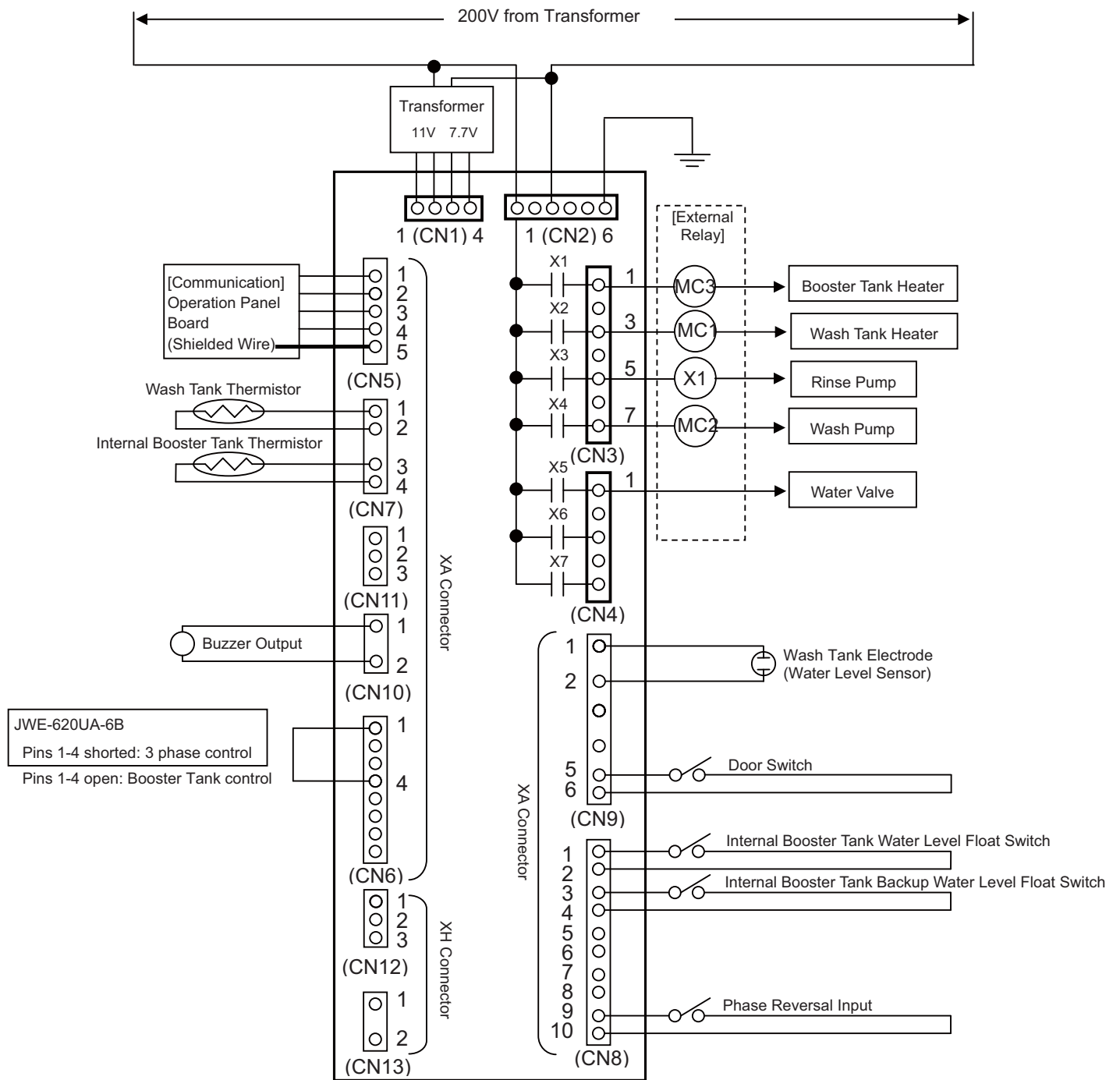

*1 Connectors CN 1 - 4 are VH Connectors

4. Operation Panel Layout

The operation panel is mounted on the side of the unit and is connected to the CN5 connector on the control board.

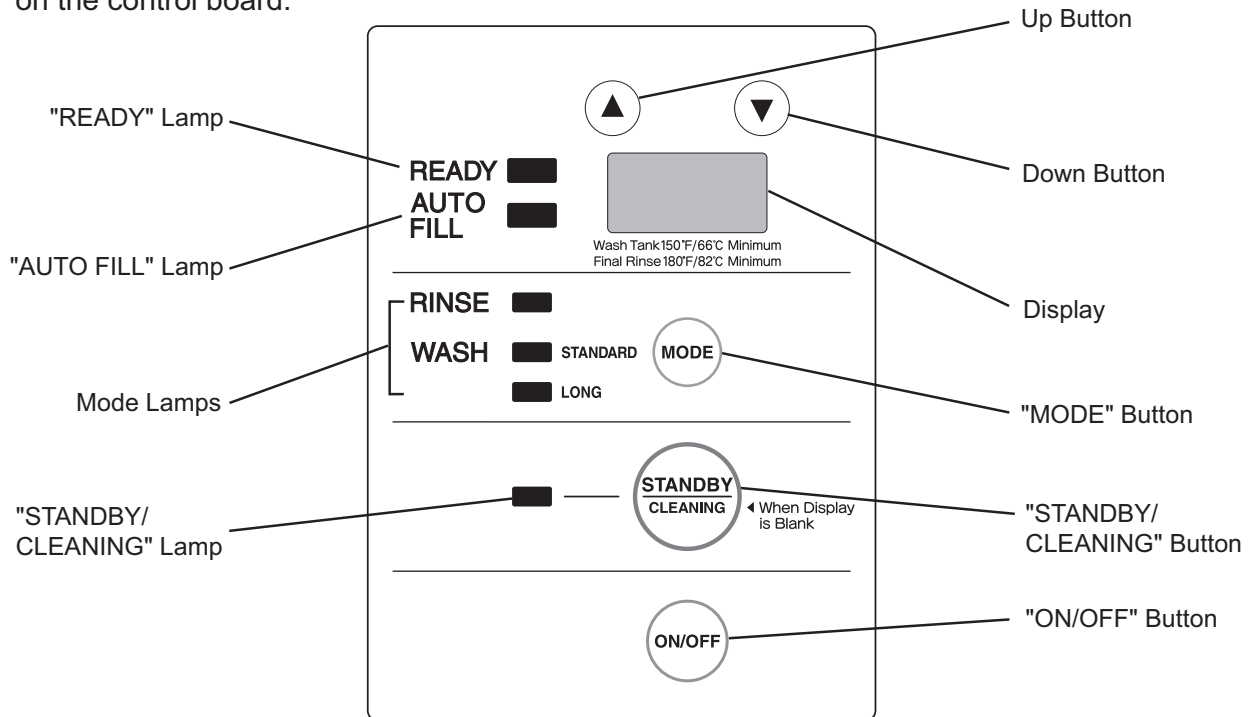

5. Features

a) Display

This operation board uses an LED display to show system details and diagnostic information.

b) Service Menu and Error Log

A service menu ("01" to "17" and "21" to "25") allows for viewing and setting of system operating details and parameters. See "II.D.7. Service Menu and Error Log."

c) Error Codes

Error codes ("A1" to "A3," "H1" to "H7," "o1," "o2") are designed to protect the unit. These codes give information or warnings in the event the unit is operating out of acceptable parameters. See "III.B. Error Codes."

6. Controls, Adjustments, and Lamps

a) "READY" Lamp

Comes on when the auto fill cycle completes and the dishwasher is ready to wash.

b) "AUTO FILL" Lamp

Flashes during the auto fill cycle, and goes off at the end of the cycle.

c) Mode Lamps

Comes on to indicate the selected operation mode, and flash during operation.

d) Standby Lamp

Comes on when the dishwasher is in the standby mode. The unit will not start even when the door is closed with this lamp on. See "II.D.6.h) "STANDBY/CLEANING" button.

e) Up Button, Down Button

Press to scroll through the service menu and adjust settings. Can also be used as follows:

▲ Press to display the total number of operations. Displays in six digits, two digits at a time.

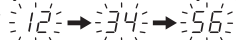
Example: 123,456 times is indicated by 

▼ Press to indicate rinse (internal booster tank) water temperature instead of wash tank water temperature while the dishwasher is in "READY" mode.

f) Display

Indicates wash tank water temperature in wash cycle, rinse (internal booster tank) water temperature in rinse cycle, and error codes.

g) "MODE" Button

Press to change the selected operation mode.

h) "STANDBY/CLEANING" Button

Press to make the dishwasher inoperable even when the door is closed (service menu item 11 set for door start) or press to start the selected mode (service menu item 11 set for "STANDBY/CLEANING" button start). For details, see "Wash/Rinse Cycle Start Initiation" (service menu item 11) in "II.D.7.b) Service Menu Chart." Press and hold to start self-cleaning when the unit has been turned off using the "ON/OFF" button.

i) "ON/OFF" Button

Turns the power on and off for operation.

Note: The power switch (GFCI) supplies power to the unit. The unit, including heaters, is inoperative until the "ON/OFF" button on the operation panel is pressed to turn the unit on.

7. Service Menu and Error Log

The service menu ("01" to "17" and "21" to "25") may be used to change settings, acquire diagnostic information, and to view error history.

a) Service Menu Access

- Enter Service Menu: Use the "ON/OFF" button to turn off the unit. Press and hold the "MODE" button, then press the "ON/OFF" button. "01" should appear on the display.
- Scroll: Use the up and down arrow buttons to scroll through the service menu list, settings, and data.
- View Service Menu Setting: Press the "MODE" button to view the selected menu setting.
- Change Setting: Use the up and down arrow buttons to change the setting value.
- Return to Service Menu List: Press the "MODE" button once again to return to the main service menu list.
- Exit Service Menu and Save Settings: Press the "STANDBY/CLEANING" button to exit the service menu and save the settings. The display goes blank.

b) Service Menu Chart

Service Menu	Item and Details	Setting Range	Display	Factory Default
01	Wash Cycle Time (Standard Mode)	1 to 99 seconds (see no. 08 for multiplier)	1 to 99	41 (41 seconds)
02	Wash Cycle Time (Long Mode)	10 to 990 seconds (see no. 09 for multiplier)	1 to 99	11 (11 seconds)
03	Rinse Cycle Time	5 to 60 seconds	5 to 60	6
04	Wash Temperature Setpoint	32 to 167°F (0 to 75°C)	32 to 167 (0 to 75)	163 (73)
05	Rinse Temperature Setpoint	32 to 185°F (0 to 85°C)	32 to 185 (0 to 85)	185 (85)
07	Auto Fill Cycle	Rinse pump energized 5 to 30 times	5 to 30	28
08	Wash Cycle Time Multiplier (Standard Mode)	1x or 10x	1 or 10	1
09	Wash Cycle Time Multiplier (Long Mode)	1x or 10x	1 or 10	10
11	Wash/Rinse Cycle Start Initiation	ON: start initiated by closing door OFF: start initiated by pressing "STANDBY/CLEANING" button	on or oF	on
12	Water Temperature Display	ON: wash water temperature displayed in ready mode or standby OFF: rinse water temperature displayed in ready mode or standby	on or oF	on
13	Temperature Display Scale	Fahrenheit or Celsius	°F or °C	°F
14	Internal Booster Tank Energy Saving Mode	ON or OFF	on or oF	oF
15	Water Temperature Drop for Internal Booster Tank Energy Saving Mode	Setpoint minus 0 to 40°F (Setpoint minus 0 to 22°C)	0 to 40 (0 to 22)	15 (8)
16	Idle Time Before Internal Booster Tank Energy Saving Mode Begins	0 to 99 minutes	0 to 99	15
17	Minimum Internal Booster Tank Water Temperature to Start Rinse Cycle (Stop Wash Cycle) when Internal Booster Tank Energy Saving Mode is On	180 to 185°F (82 to 85°C)	180 to 185 (82 to 85)	180 (82)
21 through 25	Error Log Note: To erase the log, press and hold the up and down buttons for 3 seconds with one of the error codes displayed. The unit beeps once and the entire log clears.	NA	Most Recent Errors 21 is most recent. "--" is displayed if the log is empty.	NA

8. Temperature Display

- Indicates the average water temperature read by the wash tank or internal booster tank thermistor. Indicates wash tank water temperature in wash cycle, rinse (internal booster tank) water temperature in rinse cycle. Press the down button to indicate rinse (internal booster tank) water temperature instead of wash tank water temperature while the dishwasher is in "READY" mode. To change the normal temperature display to the rinse (internal booster tank) water temperature, see "Water Temperature Display" (service menu item 12) in "II. D.7.b) Service Menu Chart."
- The temperature display range is 32°F to 199°F (0°C to 99°C). To change the display scale, see "Temperature Display Scale" (service menu item 13) in "II.D.7.b) Service Menu Chart."
- The temperature display updates every 30 seconds for the wash tank and every 5 seconds for the internal booster tank.

9. Error Codes

In the event of operation outside of normal parameters, the control board identifies the issue with an error code and beeps. If more than one error occurs, the display cycles through the relevant error codes. For service corrections, see "III.B. Error Codes."

Error Codes	
A1	Wash Tank Auto Fill Error
A2	Internal Booster Tank Auto Fill Error
A3	Wash Tank Water Level Error
o1	Internal Booster Tank Water Level Error 1 (Internal Booster Tank Water Level Float Switch Closed)
o2	Internal Booster Tank Water Level Error 2 (Internal Booster Tank Water Level Float Switch Open)
H1	Wash Tank Thermistor Error (short)
H2	Wash Tank Thermistor Error (open)
H3	Internal Booster Tank Thermistor Error (short)
H4	Internal Booster Tank Thermistor Error (open)
H5	ROM/RAM Error
H6	EEPROM Error
H7	Phase Reversal Error

10. Buzzer

- At the end of an auto fill cycle or other mode operation, the buzzer turns on for 0.1 second and off for 0.1 second 10 times.
- In case of an error, the buzzer turns on for 0.1 second and off for 0.9 second repeatedly until the error is reset. To turn off the beep, press the down button.
- When a button is pressed, the buzzer turns on for 0.1 second.
- To adjust the buzzer volume, use the volume control on the control board.

11. Special Modes

a) Internal Booster Tank Energy Saving Mode

The internal booster tank energy saving mode allows the internal booster tank temperature to drop during periods of inactivity. To activate or deactivate the internal booster tank energy saving mode, see "Internal Booster Tank Energy Saving Mode" (service menu item 14) in "II.D.7.b) Service Menu Chart."

After a period of inactivity from 0 to 99 minutes (service menu item 16), the temperature to maintain is dropped to the setpoint minus 0°F to 40°F (0°C to 22°C) (service menu item 15).

Adjust the water temperature drop so that the rinse (internal booster tank) water temperature rises enough to be at least 180°F (82°C) after the wash cycle.

The minimum rinse (internal booster tank) water temperature for the unit to switch out of the wash cycle and into the rinse cycle can be set from 180°F to 185°F (82°C to 85°C) (service menu item 17). If the minimum temperature has not been reached at the end of the preset wash cycle time (service menu item 01 or 02), the wash cycle is extended up to 60 seconds until the temperature is reached. If the temperature is not reached in 60 seconds, the unit goes into ready mode. This setting only applies when the energy saving mode is activated.

Note:

The default water temperature drop of setpoint minus 15°F (8°C) was based on test results under the following conditions:

Supply Voltage: 230V

Water Supply Temperature 109°F (43°C)

Rinse Cycle Time: 6 seconds (0.53 gal/rack)

Dwell Time: 5 seconds

Ambient Temperature: 77°F (25°C)

b) Continuous Wash Mode

The continuous wash mode (also used when descaling) allows the wash pump motor to run continuously. In this mode, the wash tank heaters and internal booster tank heaters remain de-energized.

To enter the continuous wash mode, use the "ON/OFF" button to turn off the unit. Press and hold the up and down buttons and the "MODE" button for 3 seconds and press the "ON/OFF" button. As long as the door switch and wash tank water level sensor are closed, the wash pump motor runs and power is supplied to the detergent feeder terminals. "PC" (preventative cleaning) appears in the display and the lamps are off.

To cancel the continuous wash mode, press the "ON/OFF" button.

c) Consecutive Rinse Mode

The consecutive rinse mode (also used in self-cleaning) allows the unit to run through 5 consecutive rinse cycles.

To enter the consecutive rinse mode, use the "ON/OFF" button to turn off the unit. With the door switch closed, press and hold the "STANDBY/CLEANING" button for 3 seconds. "SC" (self cleaning) appears in the display and the "RINSE" lamp is on.

After running through 5 consecutive cycles, the buzzer beeps, then the unit turns off.

III. Service Diagnosis

⚠ WARNING

1. This unit should be diagnosed and repaired only by qualified service personnel to reduce the risk of death, electric shock, serious injury, or fire.
2. Risk of electric shock. Use extreme caution and exercise safe electrical practices.
3. Moving parts (e.g., fan blade) can crush and cut. Keep hands clear.
4. Do not make any alterations to the unit. This could cause water leak, electric shock, or fire.
5. To help reduce the risk of electric shock, do not touch switches with damp hands.

A. Diagnostic Procedure

The diagnostic procedure is a sequence check of the switches and sensors while operating the unit, by using the switch open/closed display mode.

Switch Open/Closed Display Mode

The switch open/closed display mode indicates when the door switch, wash tank water level sensor, internal booster tank water level float switch, and internal booster tank backup water level float switch are open or closed.

To enter the switch open/closed display mode, use the "ON/OFF" button to turn on the unit. Press and hold the up and down buttons for 3 seconds. The following appears in the display:

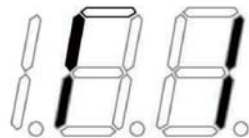

Close the door and start a cycle. The display indicates whether a switch is open or closed. When a switch is closed, its corresponding segment is illuminated in the display. See the illustration below.

To resume the normal display, press the down button.

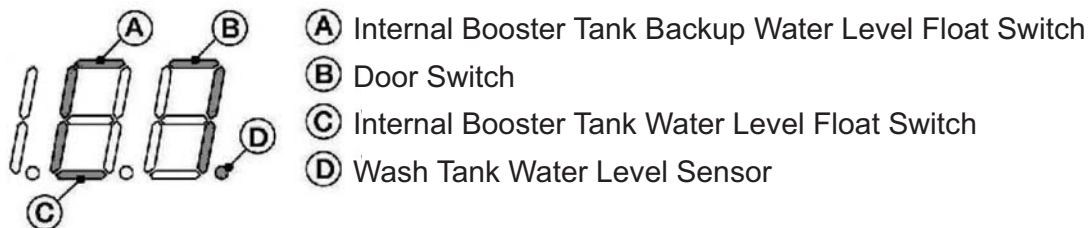

It is recommended to conduct this sequence check in the auto fill cycle after draining the wash tank and internal booster tank. See “II.B. Sequence of Operation” for further details.

- 1) Move the power switch (GFCI) to the “OFF” position.
- 2) Pull out the overflow pipe to drain the wash tank.
- 3) Drain the internal booster tank through the drain hose.
- 4) Replace the overflow pipe and drain hose in their correct positions.
- 5) Enter the switch open/closed display mode according to the above procedure.
- 6) Auto Fill Cycle
 - a. When the door is closed and the door switch closes, segment B in the display comes on, and the inlet water valve opens to start water supply.
 - b. After a while, the internal booster tank water level float switch closes, segment C in the display comes on, and the inlet water valve closes to stop water supply.
 - c. The rinse pump starts to feed water to the wash tank. When the internal booster tank water level goes down, the water level float switch opens, segment C in the display goes off, and the inlet water valve opens to start water supply.
 - d. After the rinse pump is energized for a preset number of times to fill the wash tank, the wash tank water level sensor closes, and segment D in the display comes on.
 - e. In normal operation, the internal booster tank backup water level float switch does not close, and segment A in the display stays off. If the internal booster tank water level float switch fails or the internal booster tank water level reaches the overflow level, segment A comes on.
- 7) Wash Cycle
 - a. When the door is opened and closed again and the door switch closes, the wash pump starts the wash cycle for a preset time. Segments B and D in the display stay on.
 - b. If the internal booster tank is below the predetermined water level, segment C in the display stays off. The inlet water valve stays open until segment C comes on.
 - c. When the wash cycle ends and the rinse cycle starts, the internal booster tank water level goes down, and segment C in the display goes off. The inlet water valve stays open until segment C comes on.

Diagnosis: If any problem is found by the above sequence check, refer to “III.B. Error Codes,” “III.C. Service Flow Charts,” “D. Float Switch Check and Cleaning” and “E. Thermistor Check.”

B. Error Codes

In the event of operation outside of normal parameters, the control board identifies the issue with an error code. For further service information, see "III.C. Service Flow Charts."

1. Error Code Table

Error Code	Problem	Operation	Reset
A1	Wash Tank Auto Fill Error Water level in wash tank does not reach water level sensor after rinse pump has run preset number of cycles.	Unit stops	Use "ON/OFF" button to turn the unit off and then back on.
A2	Internal Booster Tank Auto Fill Error In auto fill cycle, internal booster tank water level float switch does not close within 10 minutes after inlet water valve is opened.	Whole unit stops	Use "ON/OFF" button to turn the unit off and then back on.
A3	Wash Tank Water Level Error Water level in wash tank goes below water level sensor in "READY" mode or in "STANDBY."	Auto fill cycle starts	After auto fill cycle ends, alarm resets.
o1	Internal Booster Tank Water Level Error 1 (Internal Booster Tank Water Level Float Switch Closed) Both internal booster tank water level float switch and internal booster tank backup water level float switch have remained closed for 1 minute.	Normal (internal booster tank heaters off)	Use "ON/OFF" button to turn the unit off and then back on.
o2	Internal Booster Tank Water Level Error 2 (Internal Booster Tank Water Level Float Switch Open) Internal booster tank water level float switch is open and internal booster tank backup water level float switch has remained closed for 1 minute.	Normal (internal booster tank heaters off)	Use "ON/OFF" button to turn the unit off and then back on.
H1	Wash Tank Thermistor Error (short) Thermistor senses abnormal temperature (at or above 231°F (110°C)).	Normal (wash tank heaters off)	After replacing failed component, alarm resets.
H2	Wash Tank Thermistor Error (open) Thermistor senses abnormal temperature (at or below -6°F (-21°C)).	Normal (wash tank heaters off)	After replacing failed component, alarm resets.
H3	Internal Booster Tank Thermistor Error (short) Thermistor senses abnormal temperature (at or above 231°F (110°C)).	Normal (internal booster tank heaters off)	After replacing failed component, alarm resets.

Error Code	Problem	Operation	Reset
H4	Internal Booster Tank Thermistor Error (open) Thermistor senses abnormal temperature (at (heater off) or below -6°F (-21°C)).	Normal (internal booster tank heaters off)	After replacing failed component, alarm resets.
H5	ROM/RAM Error Control board ROM/RAM fails.	Unit stops	After replacing control board, alarm resets.
H6	EEPROM Error EEPROM fails.	Unit stops	After replacing control board, alarm resets.
H7	Phase Reversal Error Power supply phase is reversed.	Unit stops	After correcting the connection by swapping two of three wires at the power switch (GFCI) connection, alarm resets.

2. Error Code Log

Use the "ON/OFF" button to turn off the unit. Press and hold the "MODE" button, then press the "ON/OFF" button. "01" should appear on the display. Use the down arrow button to scroll to service menu items 21 through 25. 21 is the most recent error. Press the "MODE" button to view the selected service menu item. Press the "MODE" button once again to return to the main service menu list. If no errors exist in the log, "--" is displayed.

Press the "STANDBY/CLEANING" button to exit the service menu. The display goes blank.

To erase the log, press and hold the up and down buttons for 3 seconds with one of the error codes displayed. The unit beeps once and the entire log clears.

3. Error Code Details

a) Auto Fill Error (A1)

- If the water level sensor in the wash tank is not closed at the end of the auto fill cycle, the unit shuts down, "A1" appears in the display, and the buzzer sounds.
- To reset, use the "ON/OFF" button to turn the unit off and then back on.
- See the chart below for possible causes and remedies.

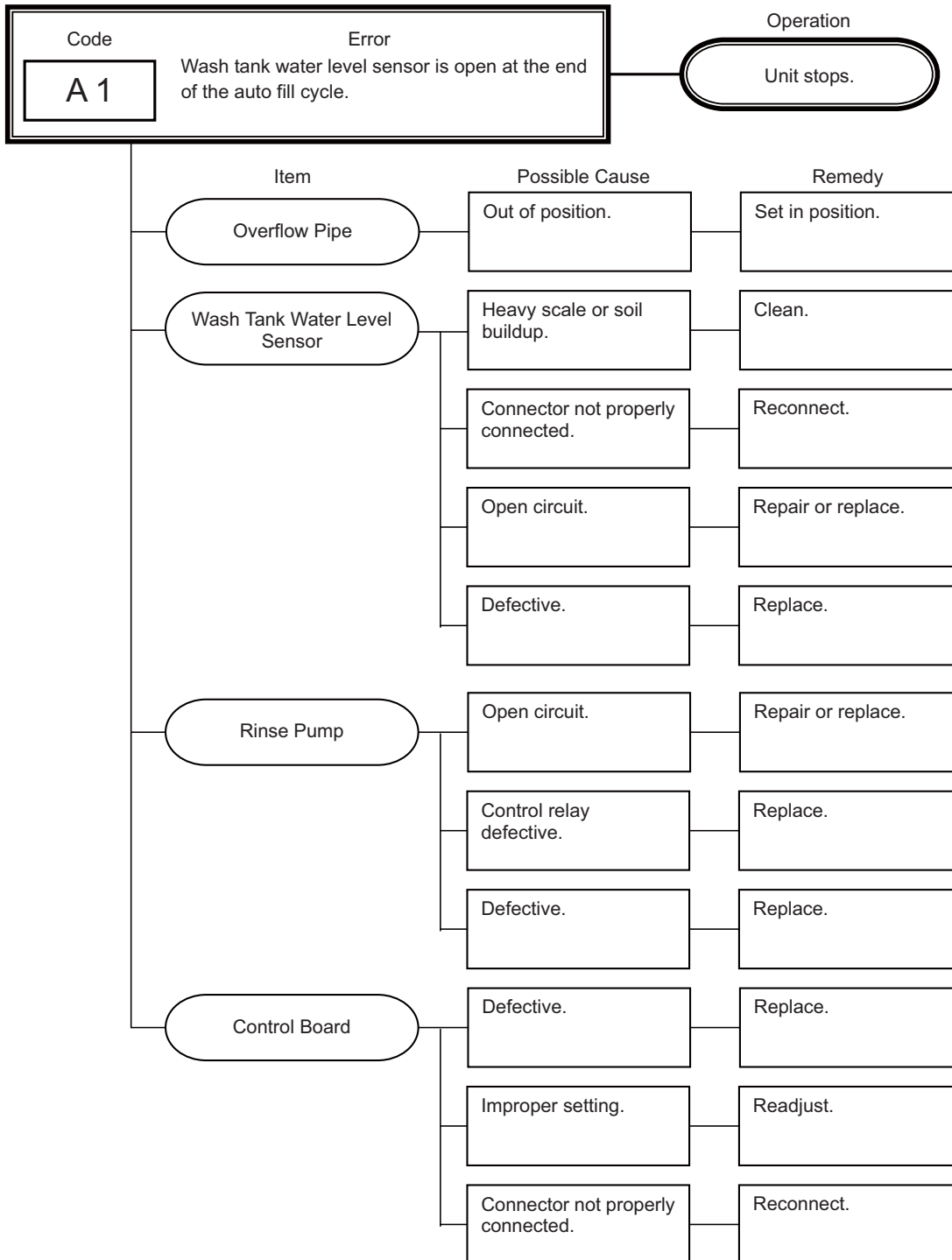

b) Internal Booster Tank Auto Fill Error (A2)

- In the auto fill cycle, if the internal booster tank water level float switch does not close within 10 minutes after the cycle starts, the unit shuts down, "A2" appears in the display, and the buzzer sounds.
- To reset, use the "ON/OFF" button to turn the unit off and then back on.
- See the chart below for possible causes and remedies.

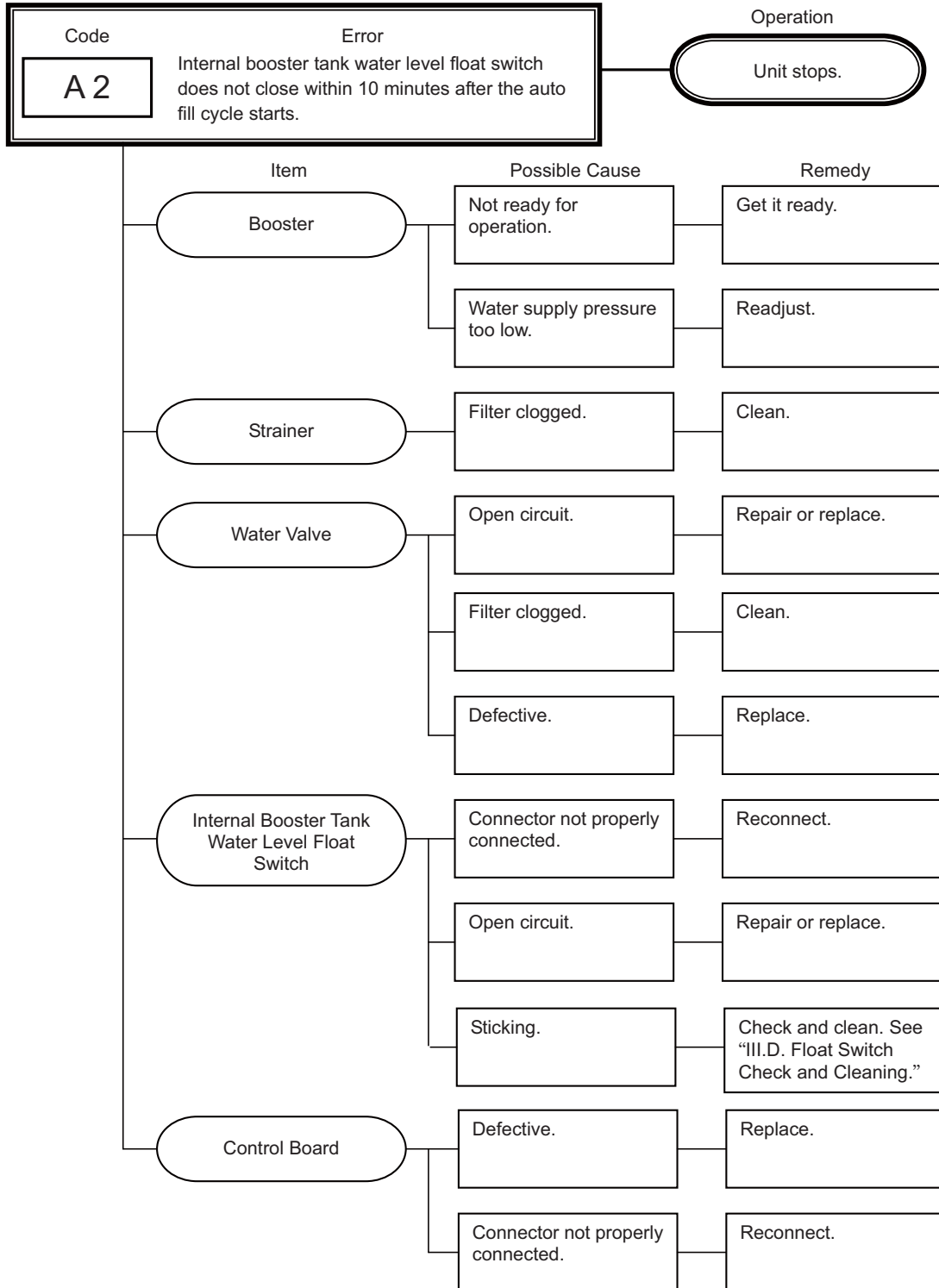

c) Wash Tank Water Level Error (A3)

- If the water level in the wash tank goes below the water level sensor in "READY" mode or in "STANDBY," the auto fill cycle starts, "A3" appears in the display, and the buzzer sounds.
- The error resets if the water level sensor is closed at the end of the auto fill cycle.
- See the chart below for possible causes and remedies.

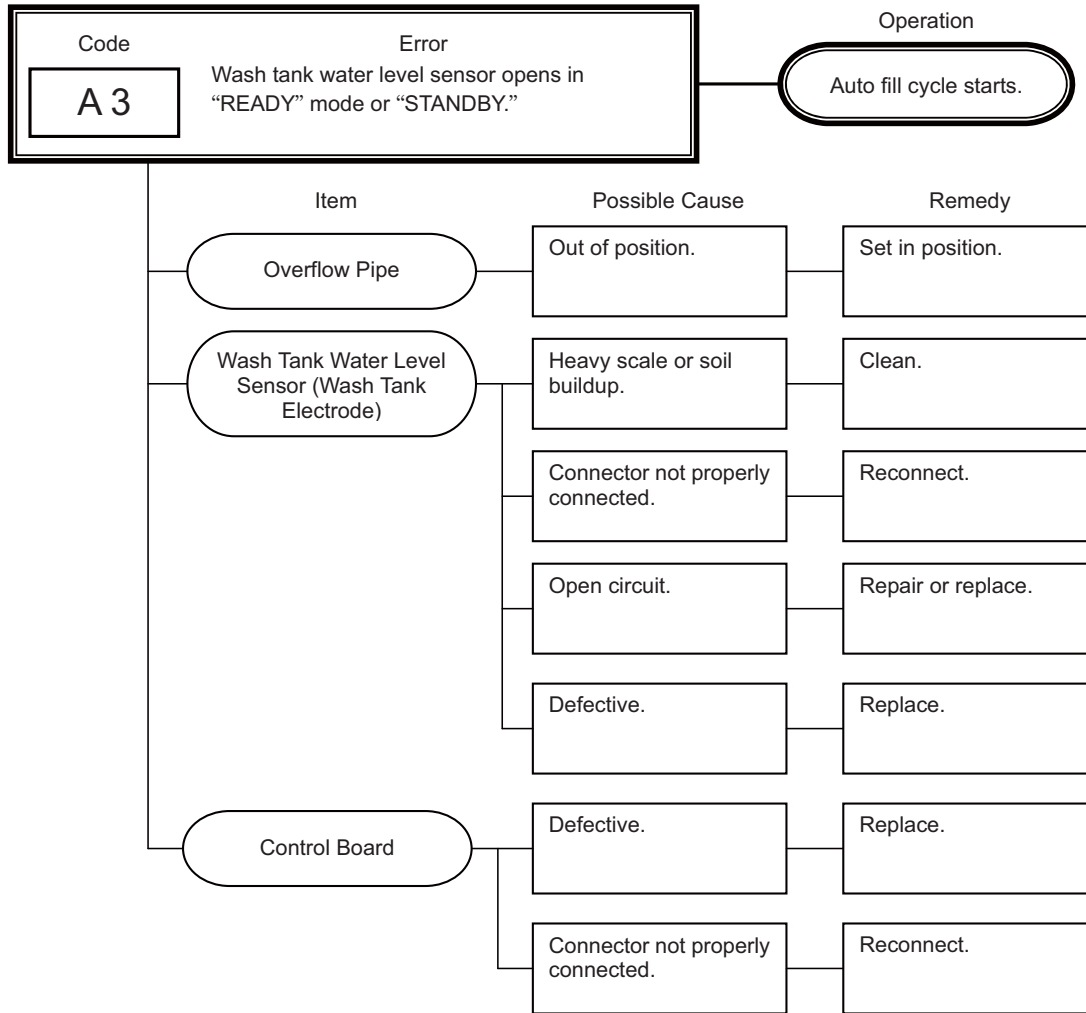

d) Internal Booster Tank Water Level Error 1 (Internal Booster Tank Water Level Float Switch Closed) (o1)

- If both the internal booster tank water level float switch and the internal booster tank backup water level float switch have remained closed for 1 minute, the internal booster tank heaters de-energize, "o1" appears in the display, and the buzzer sounds.
- The error resets if the internal booster tank backup water level float switch opens or when the "ON/OFF" button is used to turn the unit off and then back on.
- See the chart below for possible causes and remedies.

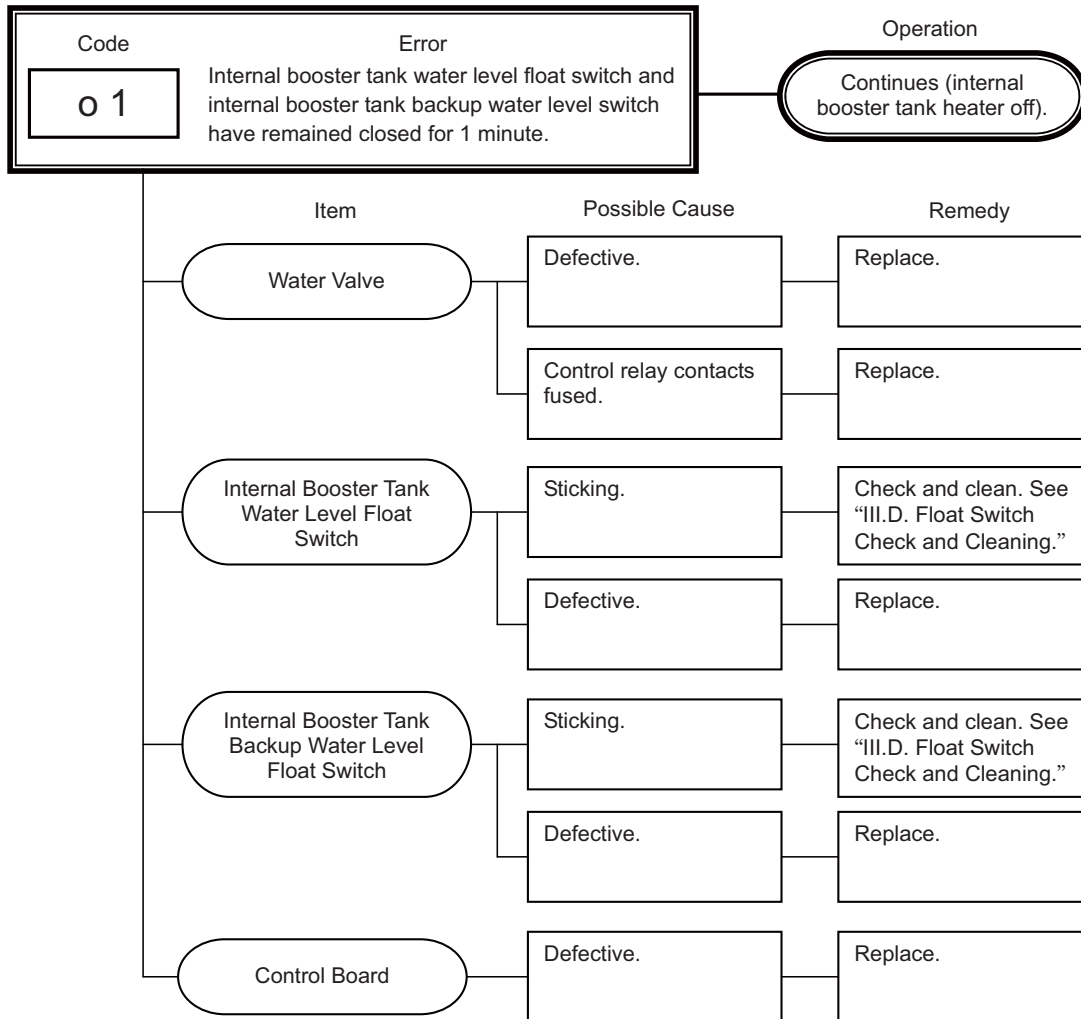

Note: See "III.D. Float Switch Check and Cleaning."

e) Internal Booster Tank Water Level Error 2 (Internal Booster Tank Water Level Float Switch Open) (o2)

- If the internal booster tank water level float switch is open and the internal booster tank backup water level float switch has remained closed for 1 minute, the internal booster tank heaters de-energize, "o2" appears in the display, and the buzzer sounds.
- The error resets if the internal booster tank backup water level float switch opens or when the "ON/OFF" button is used to turn the unit off and then back on.
- See the chart below for possible causes and remedies.

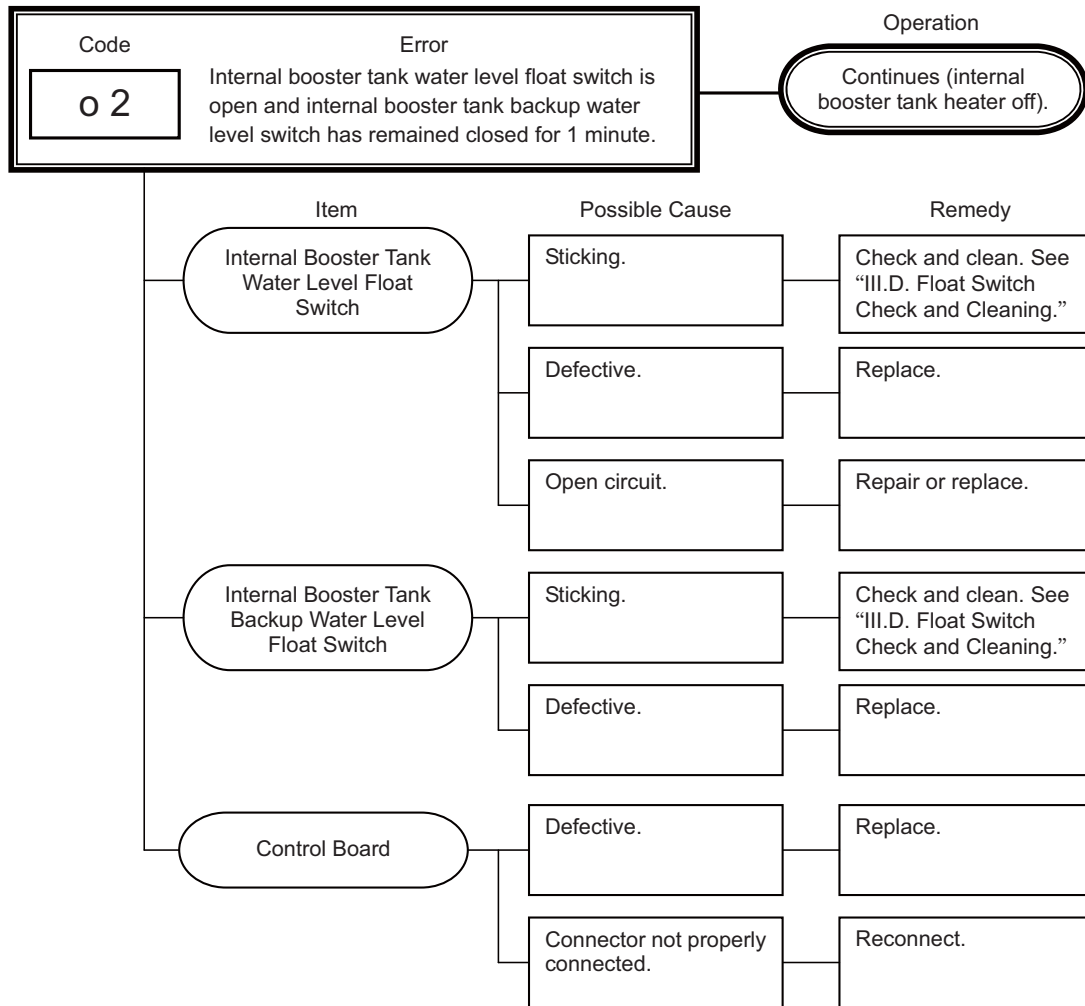

Note: See "III.D. Float Switch Check and Cleaning."

f) Wash Tank Thermistor Error (H1, H2)

- If the wash tank thermistor senses a temperature at or above 231°F (111°C) (2.4kΩ), the thermistor leads are considered shorted and the wash tank heaters de-energize, "H1" appears in the display, and the buzzer sounds.
 - If the wash tank thermistor senses a temperature at or below -6°F (-21°C) (517kΩ), the thermistor leads are considered open and the wash tank heaters de-energize, "H2" appears in the display, and the buzzer sounds.
 - After replacing the failed component, the alarm resets.
 - See the chart below for possible causes and remedies.
- Note: When this error occurs, the auto fill cycle will not start.

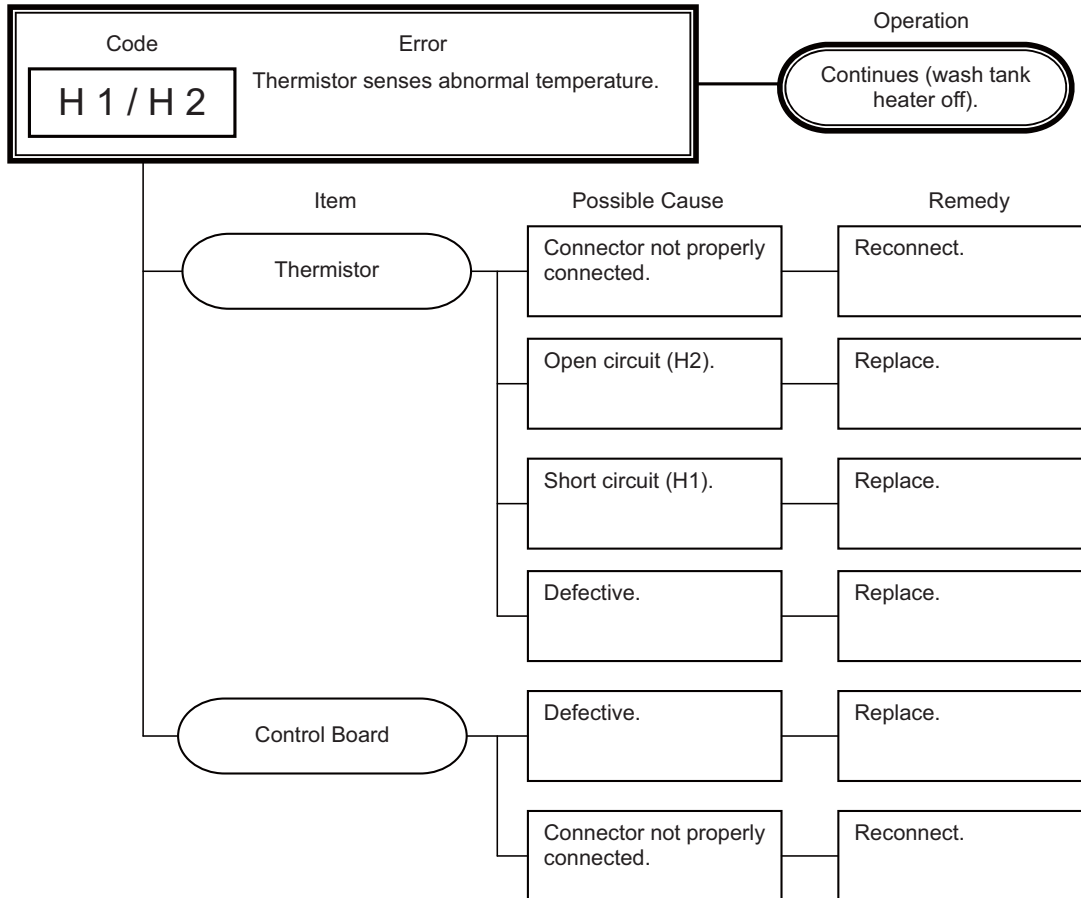

Note: See “III.E. Thermistor Check” and “IV.M. Removal and Replacement of Thermistor.”

g) Internal Booster Tank Thermistor Error (H3, H4)

- If the internal booster tank thermistor senses a temperature at or above 231°F (111°C) (2.4kΩ), the thermistor leads are considered shorted and the internal booster tank heaters de-energize, "H3" appears in the display, and the buzzer sounds.
 - If the internal booster tank thermistor senses a temperature at or below -6°F (-21°C) (517kΩ), the thermistor leads are considered open and the internal booster tank heaters de-energize, "H4" appears in the display, and the buzzer sounds.
 - After replacing the failed component, the alarm resets.
 - See the chart below for possible causes and remedies.
- Note: When this error occurs, the auto fill cycle will not start.

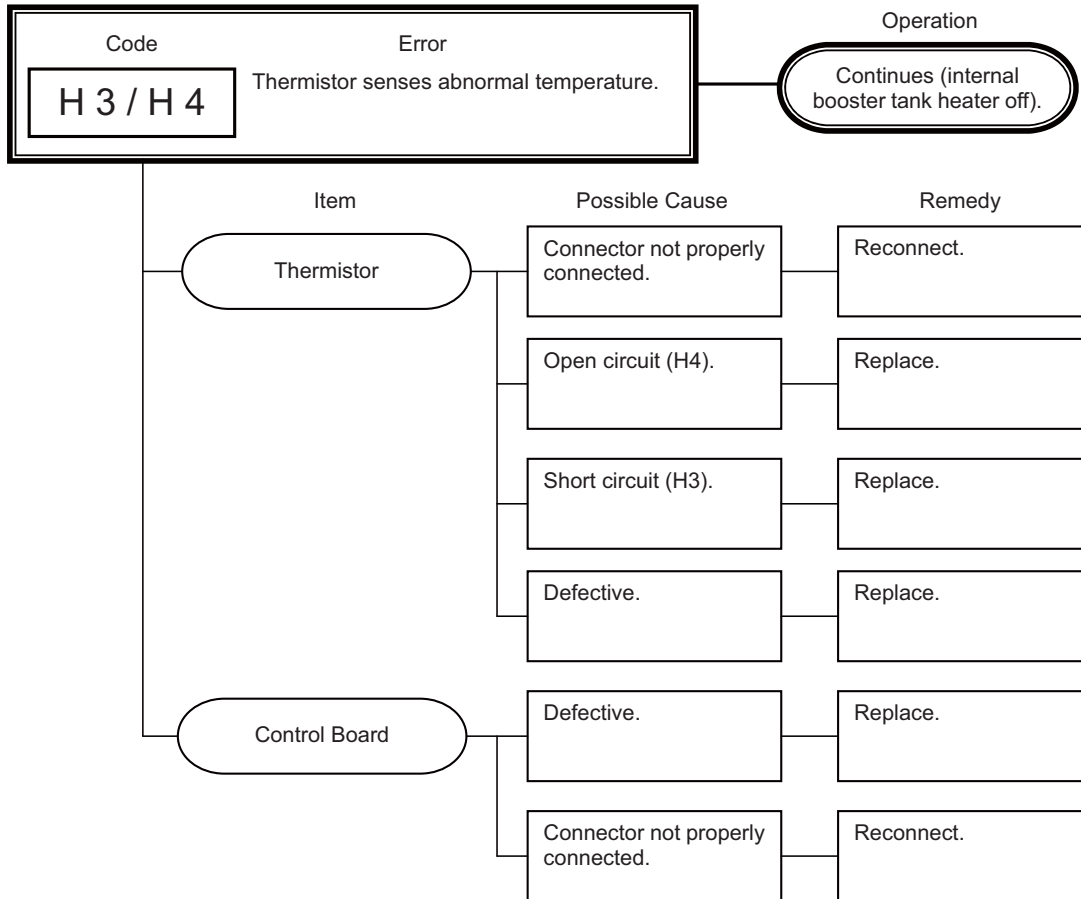

Note: See “III.E. Thermistor Check” and “IV.M. Removal and Replacement of Thermistor.”

h) ROM/RAM Error (H5)

- If a ROM/RAM error is detected, the unit shuts down, "H5" appears in the display, and the buzzer sounds.
- After replacing the failed component, the alarm resets.
- See the chart below for possible causes and remedies.

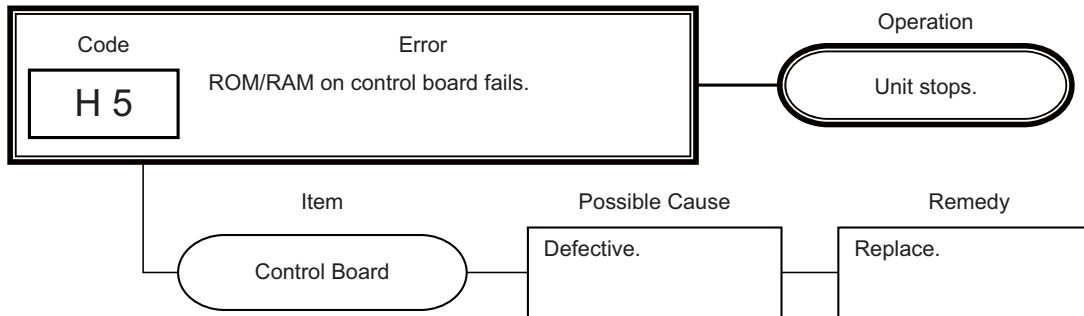

i) EEPROM Error (H6)

- If an EEPROM error is detected, the unit shuts down, "H6" appears in the display, and the buzzer sounds.
- After replacing the failed component, the alarm resets.
- See the chart below for possible causes and remedies.

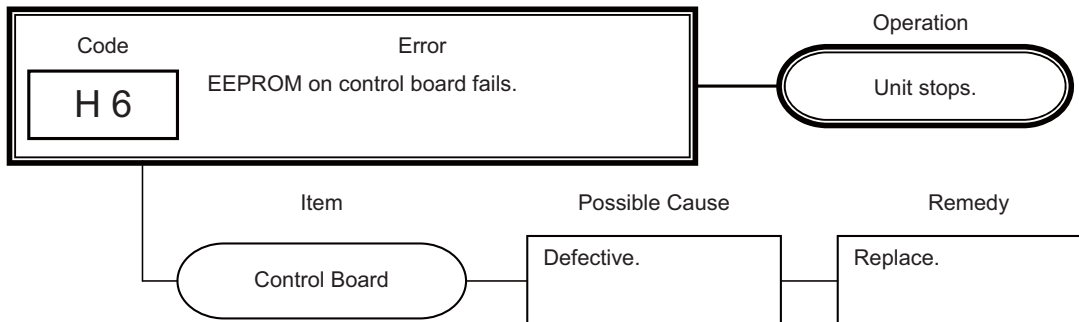

Note: See "IV.N. Removal and Replacement of Control Board or Operation Board."

j) Phase Reversal Error (H7)

- If a phase reversal error is detected, the unit shuts down, "H7" appears in the display, and the buzzer sounds.
- After correcting the connection, the alarm resets.
- See the chart below for possible causes and remedies.

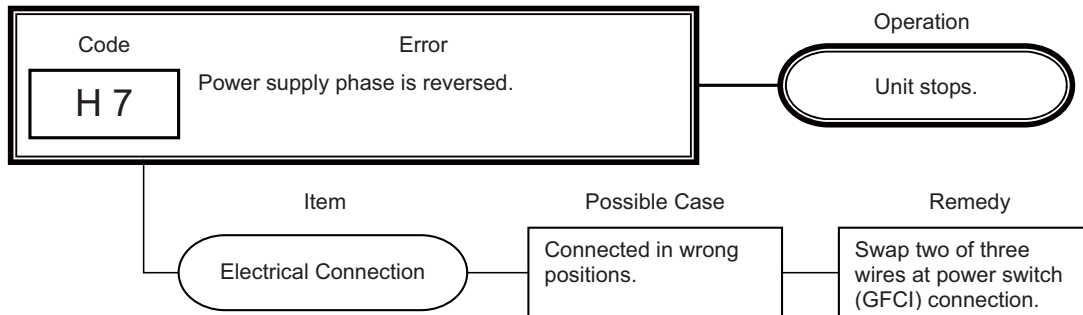

C. Service Flow Charts

1. Unit Will Not Start

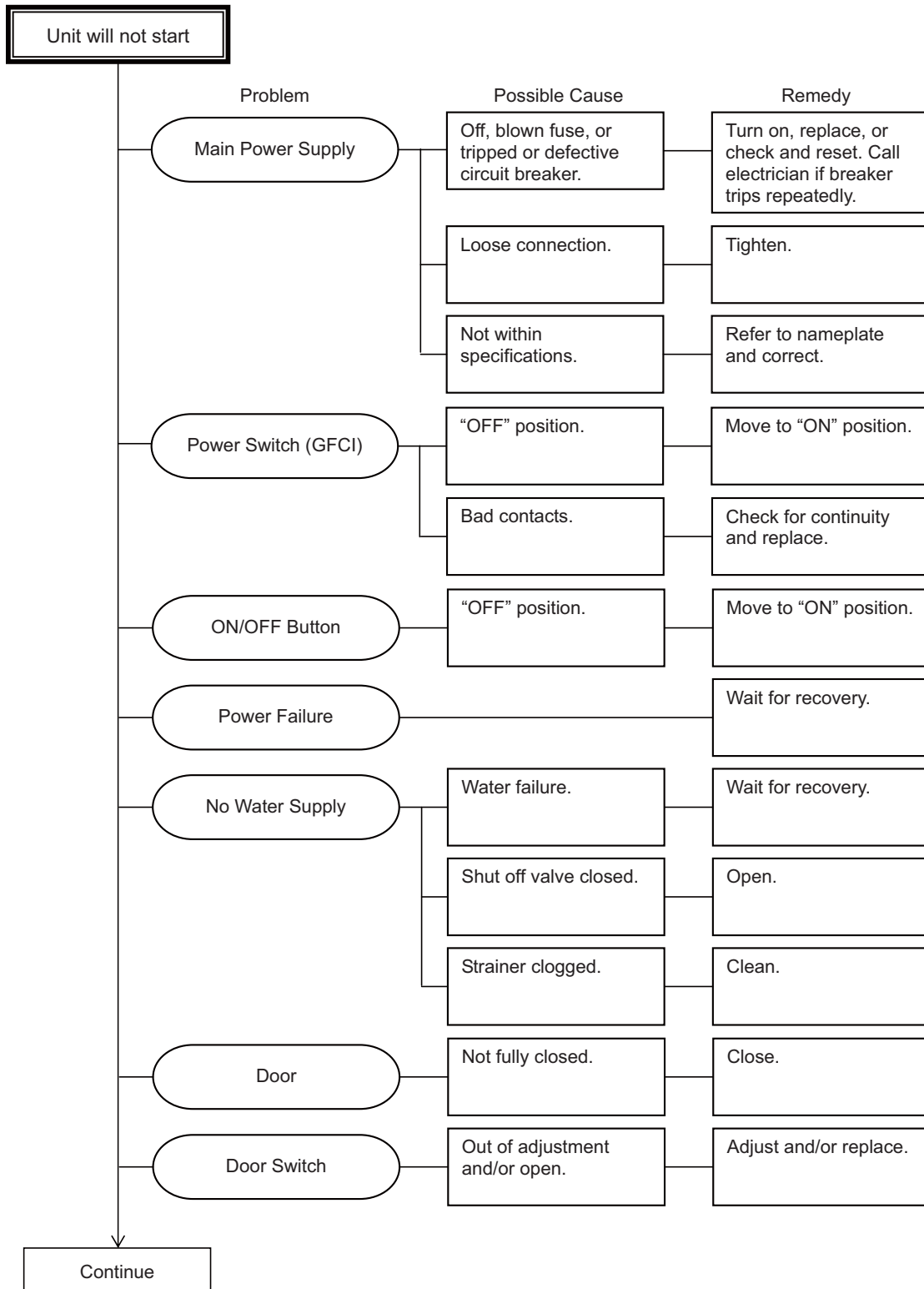

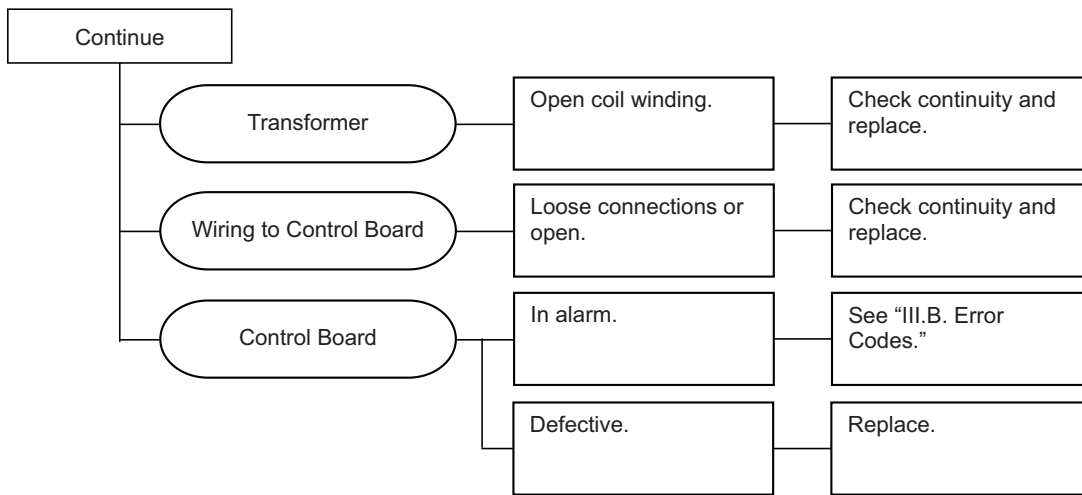

2. Dishes Not Clean

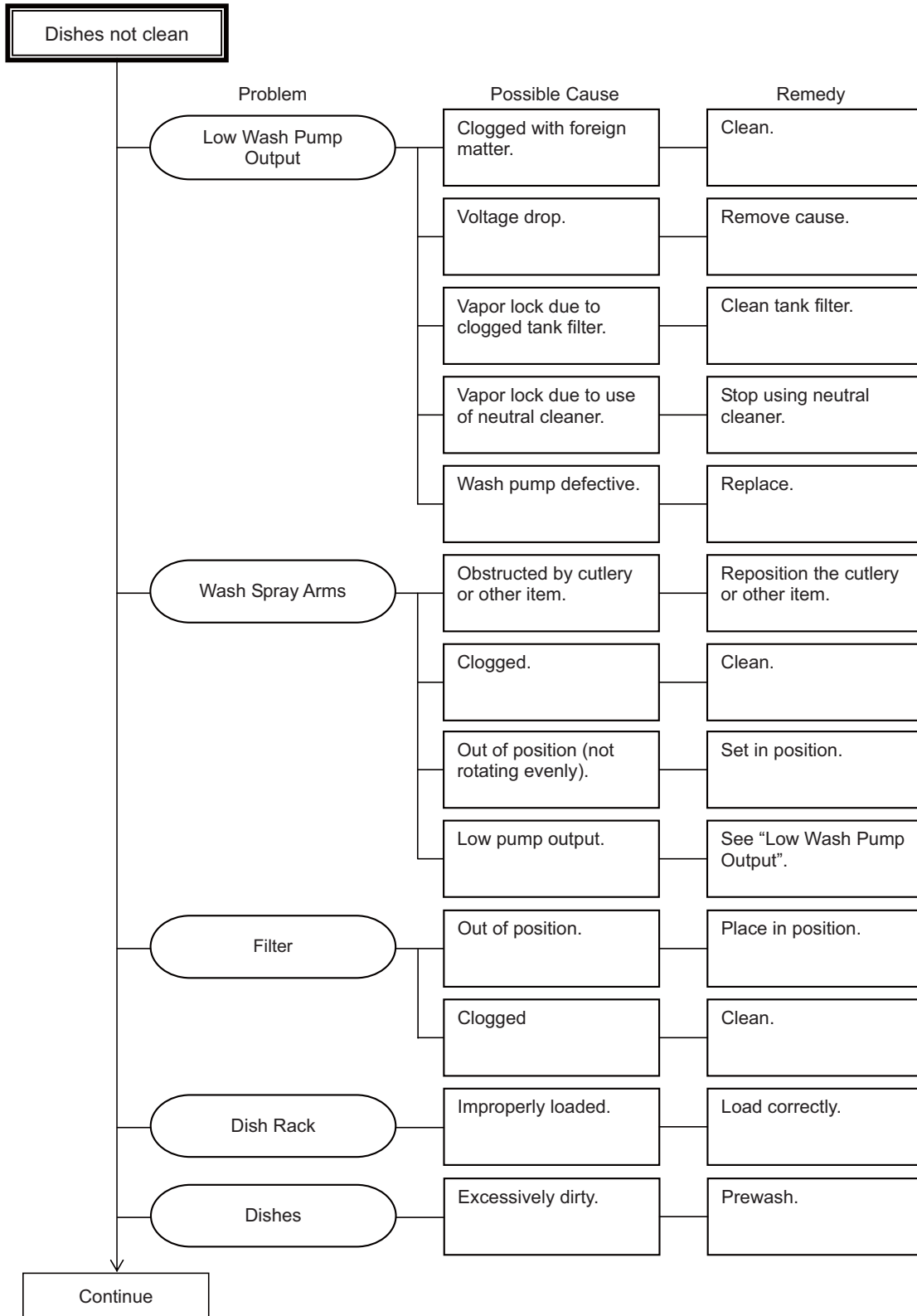

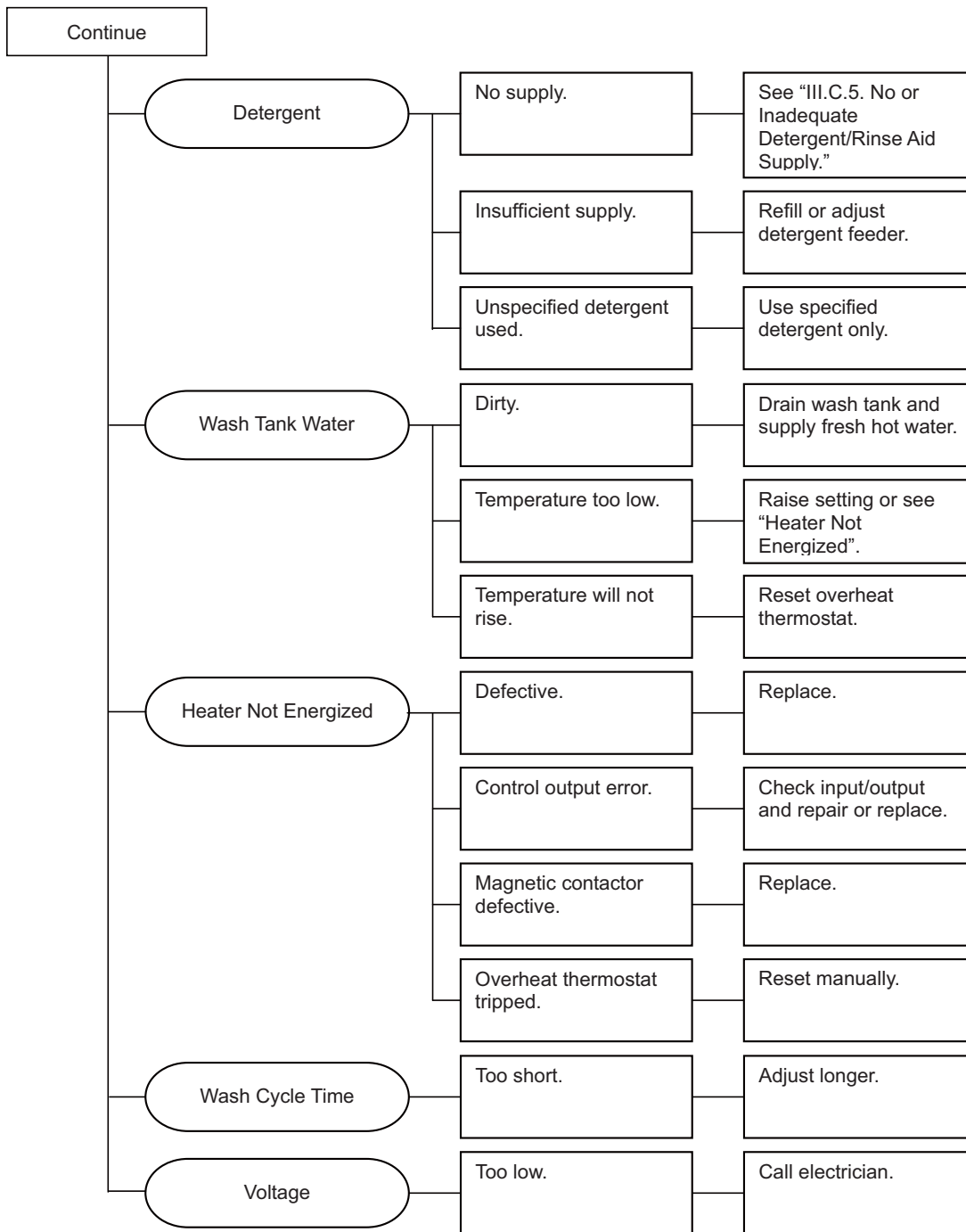

3. Inadequate Rinse

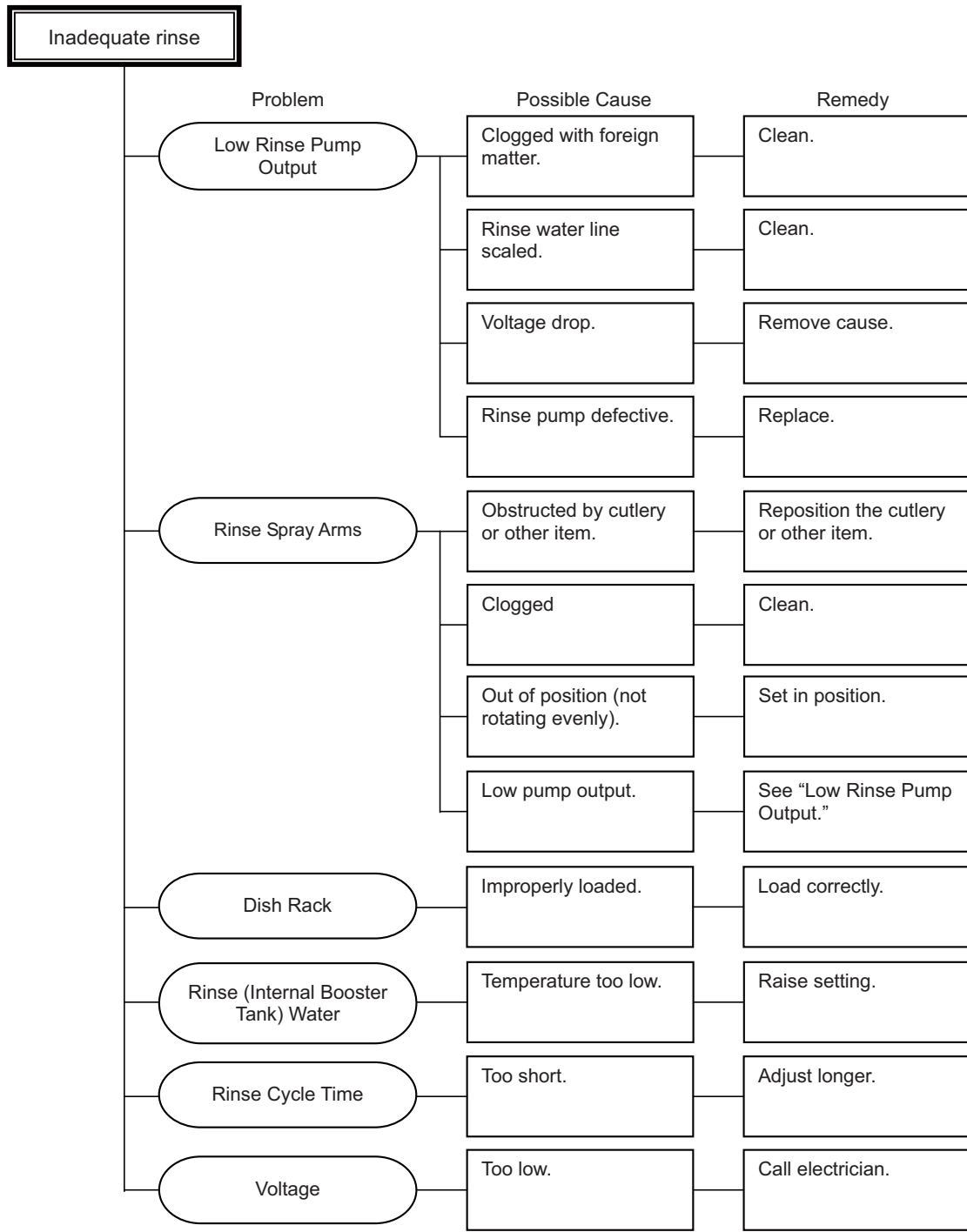

4. Dishwasher Will Not Start When Door Closed

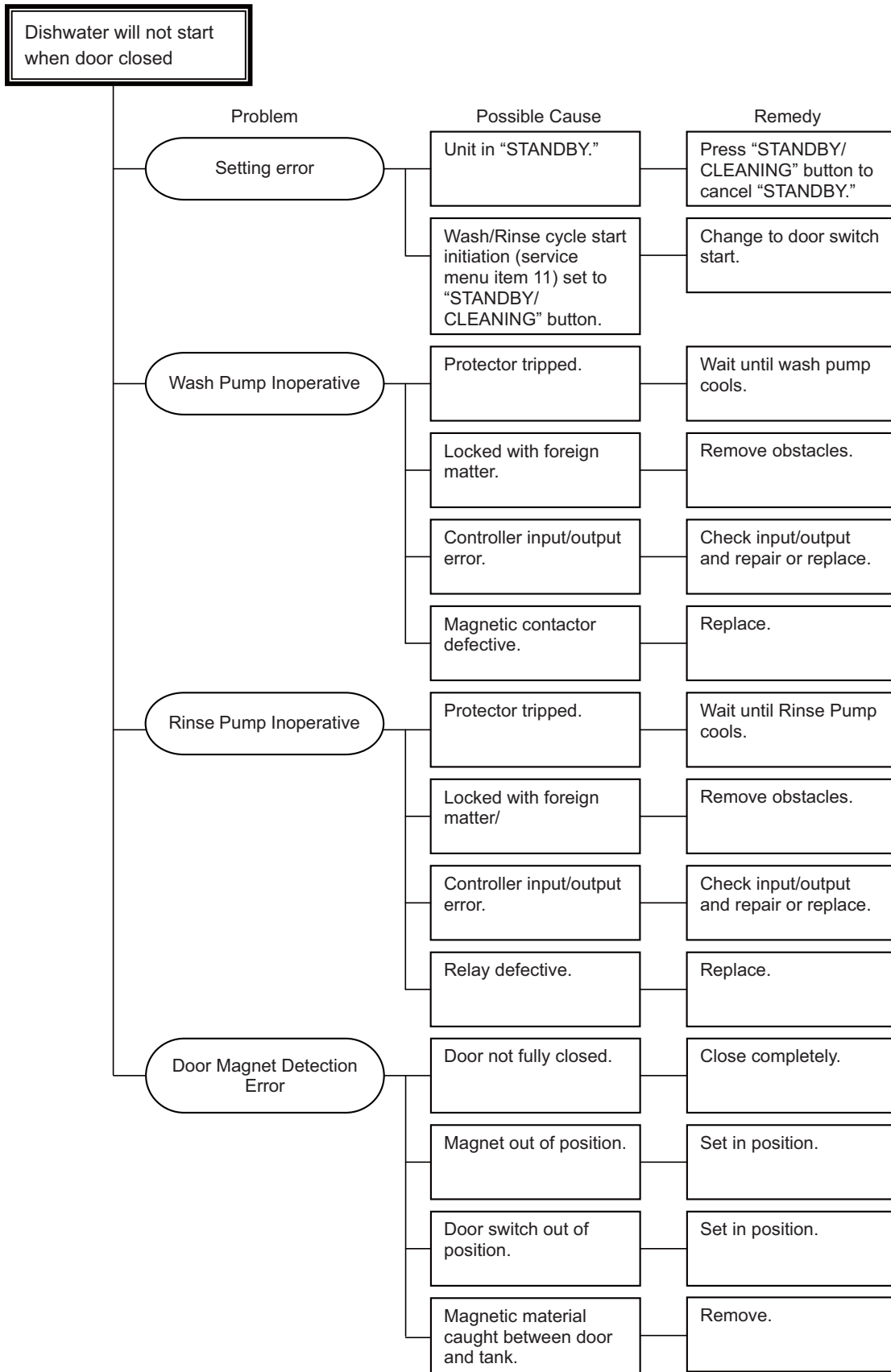

5. No or Inadequate Detergent/Rinse Aid Supply

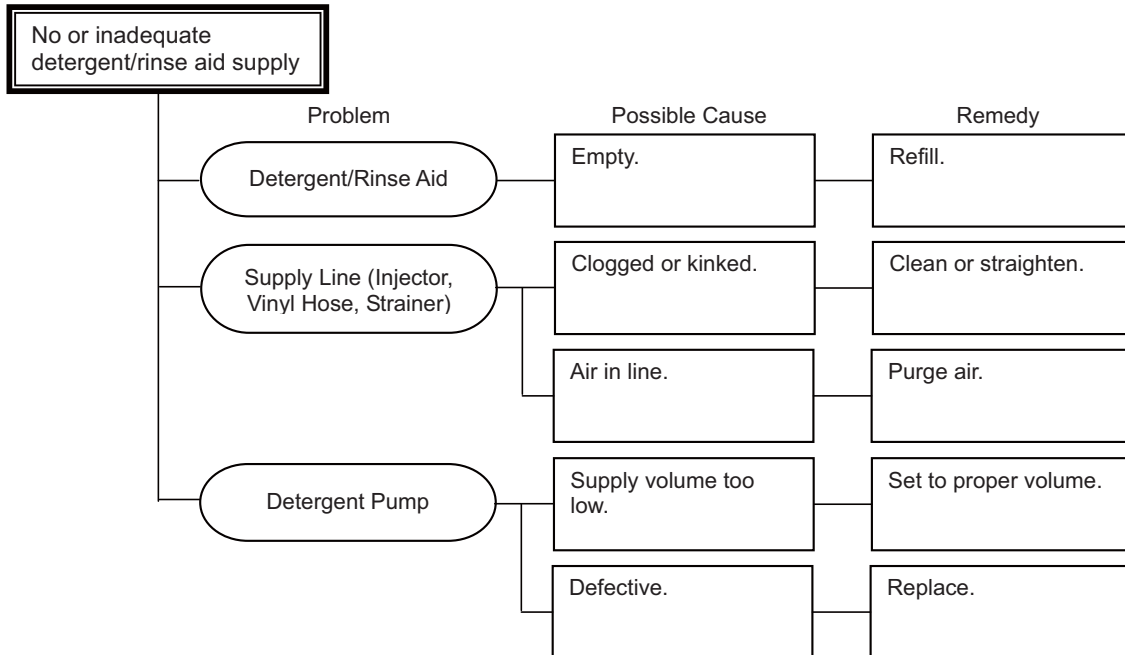

6. Wash Tank Water Boils

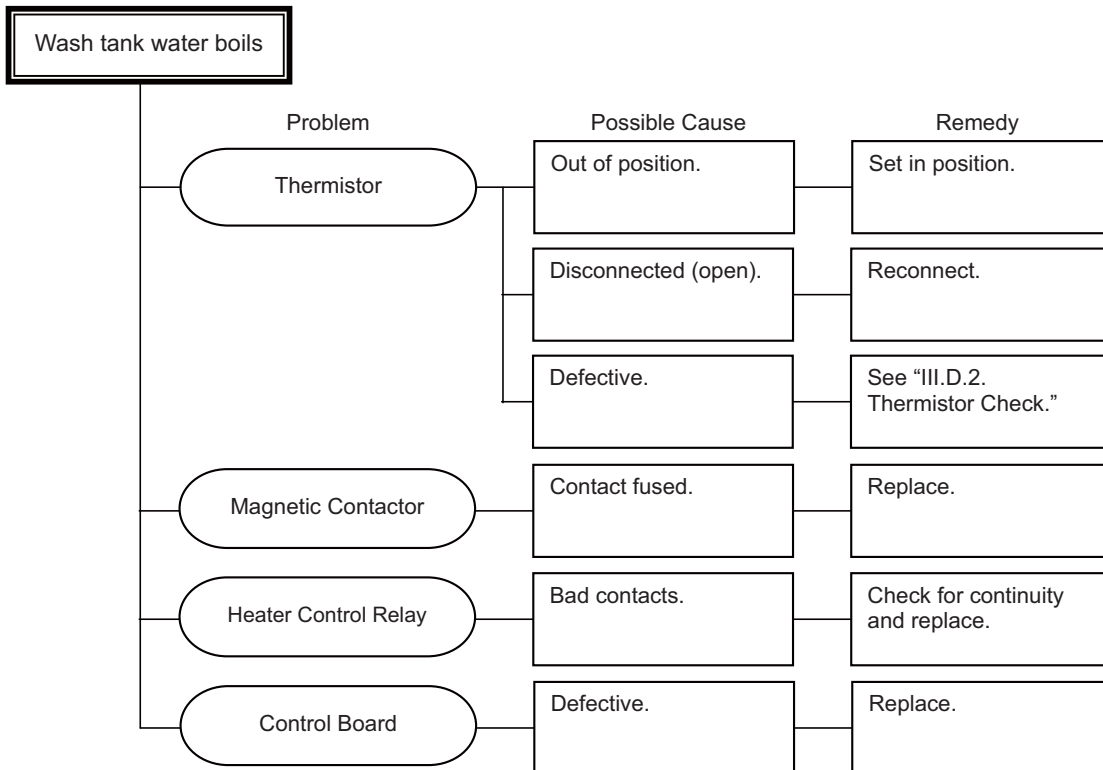

Note: See "III.E. Thermistor Check" and "IV.M. Removal and Replacement of Thermistor."

7. Wash Tank Water Not Draining

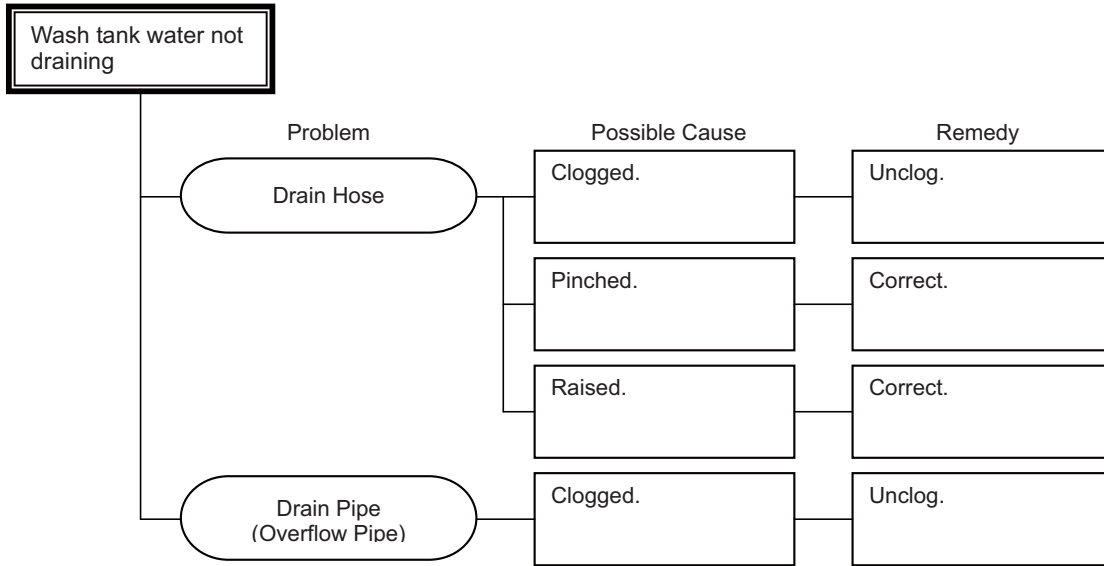

D. Float Switch Check and Cleaning

If an abnormal input signal is found by “III.A. Diagnostic Procedure” or the error code “o1” or “o2” is displayed, check and clean/replace the float switch according to the procedure below.

1. Float Switch Check

To check the float switch, follow the steps below.

- 1) Remove the internal booster tank according to “IV.C. Removal and Replacement of Internal Booster Tank.”
- 2) Remove the control box cover, and disconnect the CN8 connector from the control board (see “II.D.2. Control Board Layout”).
- 3) To check the internal booster tank water level float switch, check for continuity across the red wires (#1 and #2) on the CN8 connector. Confirm that the float switch is open when the float is down and closed when the float is up.
- 4) To check the internal booster tank backup water level float switch, check for continuity across the blue wires (#3 and #4) on the CN8 connector. Confirm that the float switch is open when the float is down and closed when the float is up.
- 5) If any problem is found, repair or replace the float switch.
- 6) If the float switch is scaled up or dirty, clean it according to “2. Float Switch Cleaning.”

2. Float Switch Cleaning

Depending on local water conditions, scale may build up on the float switch. Scale on the switch can cause the float to stick. In this case, the float switch should be cleaned.

- 1) Remove the internal booster tank according to “IV.C. Removal and Replacement of Internal Booster Tank.”
- 2) Use a soft brush to remove scale or soil on the float switch, or wipe down the float switch with a mixture of 1 part of recommended cleaner Hoshizaki “Scale Away” or “LIME-A-WAY” (Economics Laboratory, Inc.) and 25 parts of warm water.
- 3) Rinse the parts thoroughly with clean water.
- 4) If the float switch is removed, replace it in its correct position. Be careful not to confuse the positions and directions of the internal booster tank water level float switch and the internal booster tank backup water level float switch. Make sure the floats can move freely in the vertical directions (see “II.A.2. Internal Booster Tank”).
- 5) Replace the internal booster tank in the reverse order of the removal procedure (see “IV. C. Removal and Replacement of Internal Booster Tank”).

E. Thermistor Check

If the error code “H1” “H2” “H3” or “H4” or an abnormal temperature [above 231°F (111° C) or below -6°F (-21°C)] appears in the display, or the wash tank water boils, check the thermistor(s) according to the procedure below. If replacement is required, see “IV.M. Removal and Replacement of Thermistor.”

- 1) Move the power switch (GFCI) to the “OFF” position, then turn off the power supply. Lockout/Tagout to prevent the power from being turned back on inadvertently.
- 2) Remove the control box cover, then disconnect the CN7 connector from the control board (see “II.D.2. Control Board Layout”).
- 3) To check the wash tank thermistor, check the resistance across the brown wires (#1 and #2). To check the internal booster tank thermistor, check the resistance across the purple wires (#3 and #4). See the table below for proper resistance and temperature relations.

Temperature [°F (°C)]	Resistance [kΩ]
194 (90)	4.30 to 4.62
176 (80)	5.87 to 6.38
158 (70)	8.13 to 8.96
140 (60)	11.5 to 12.8
104 (40)	24.3 to 28.0
68 (20)	56.3 to 67.1
32 (0)	145.6 to 180.6

- 4) If any problem is found, replace the thermistor according to “IV.M. Removal and Replacement of Thermistor.”

IV. Removal and Replacement of Components

WARNING

1. This unit should be diagnosed and repaired only by qualified service personnel to reduce the risk of death, electric shock, serious injury, or fire.
2. Move the power switch (GFCI) to the "OFF" position and turn off the power supply before servicing. Lockout/Tagout to prevent the power from being turned back on inadvertently.
3. When draining the internal booster tank, wait until the water temperature falls below 104°F (40°C) to avoid possible burns.
4. To avoid possible burns and spills, be sure to drain the wash tank and internal booster tank and let the components cool before servicing.
5. When disassembling components that have been in contact with detergent, wear rubber gloves and goggles. Before starting disassembly, thoroughly read the detergent safety instructions. Contact with skin may cause irritation and contact with eyes may cause blindness.
6. When reassembling components, be sure to use new O-rings and gaskets.

A. Removal of Panels

- 1) The front panel and side panels (L) and (R) are inserted inside the tank rim at the top and secured with 2 screws at the bottom. Unscrew and pull down to remove.
- 2) To replace, reverse the above procedure.

B. Accessing the Control Box

- 1) Remove the front panel.
- 2) Remove the screw securing the control box, then pull it straight towards you.
- 3) Remove the 1 screw at the front, 3 screws at the left side and 1 screw at the right side of the control box securing control box covers (A) and (B). Pull control box cover (A) towards you to avoid the GFCI switch, then lift off. Next, remove control box cover (B).
- 4) To replace, reverse the above procedure. Insert control box cover (B) under the rear hook of the control box. Place control box cover (A) over control box cover (B).
Note: When sliding in the control box, be careful not to damage the wiring and fan at the rear.
- 5) The wires coming out of the bushing at the front of the control box must be sloped downward to prevent entrance of water into the control box. Use the wire retainer in front of the rinse pump motor to secure the wiring.
- 6) Make a trial run to check for proper operation.

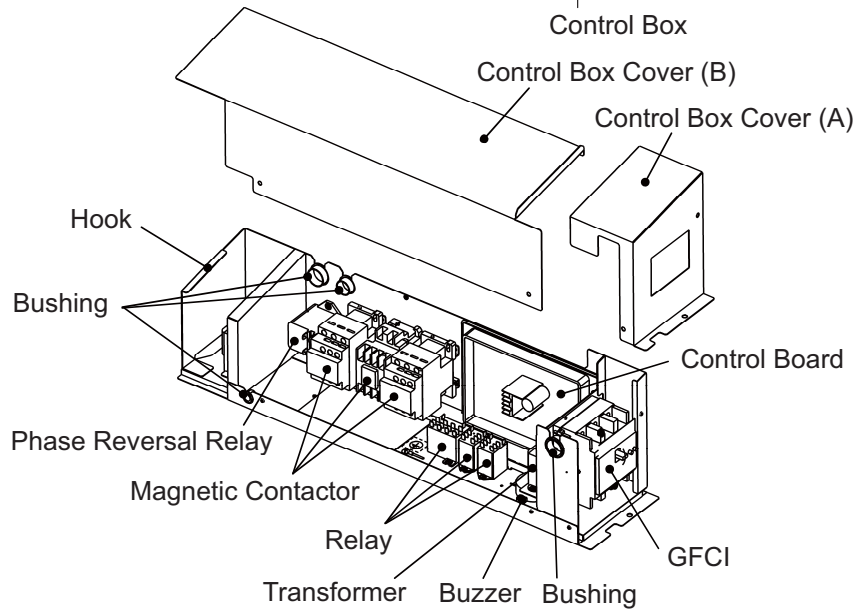
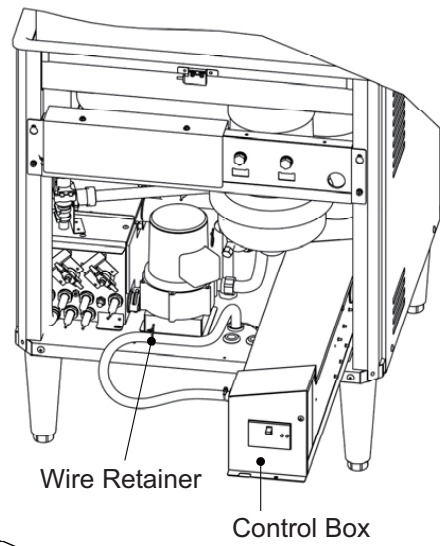
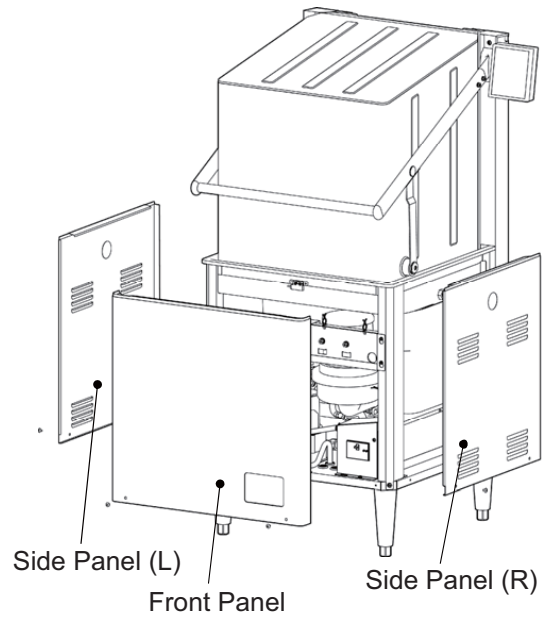

C. Removal and Replacement of Internal Booster Tank

- 1) Move the power switch (GFCI) to the "OFF" position, then turn off the power supply. Lockout/Tagout to prevent the power from being turned back on inadvertently.
- 2) Close the water supply line shut-off valve.
- 3) Use the internal booster tank drain hose to drain the internal booster tank. **WARNING! To avoid possible burns, allow the internal booster tank water temperature to fall below 104°F (40°C) before draining.**
- 4) Move the power switch (GFCI) to the "ON" position. Press the "ON/OFF" button to turn on the unit. Leave the unit on for 3 to 5 seconds to operate the water valve and remove any water inside the water supply pipe. Move the power switch (GFCI) to the "OFF" position, then turn off the power supply. Lockout/Tagout to prevent the power from being turned back on inadvertently.
- 5) Loosen and disconnect the rinse pump discharge line.
- 6) Remove the band (clip) connecting the rinse pump and internal booster tank.
- 7) Unscrew and remove the rinse pump from the internal booster tank.
- 8) Loosen and remove the nut connecting the water valve and water supply pipe.
- 9) Remove the screw securing the internal booster tank and the connector for the water valve. Pull out the internal booster tank.
- 10) Unscrew the internal booster tank cover.
- 11) To replace, reverse the above procedure.

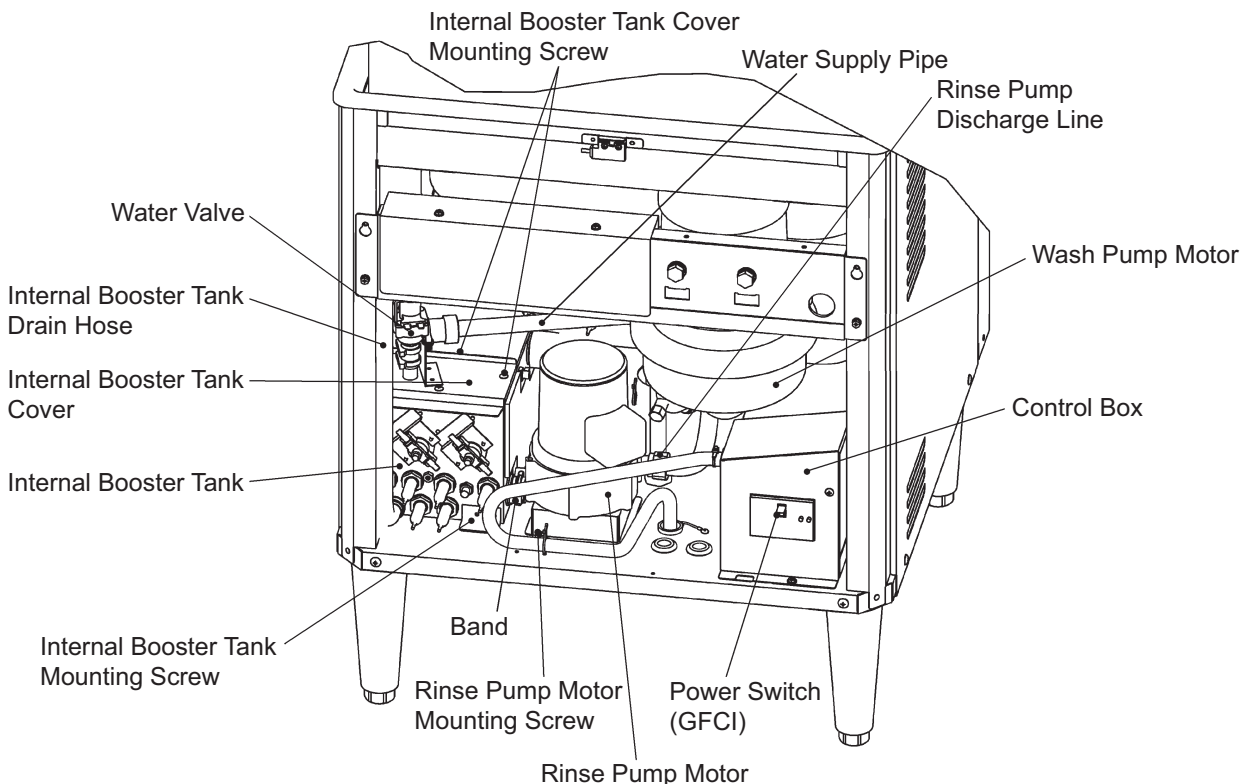

D. Removal and Replacement of Wash Pump Motor

To remove:

- 1) Move the power switch (GFCI) to the "OFF" position, then turn off the power supply. Lockout/Tagout to prevent the power from being turned back on inadvertently.
- 2) Drain the wash tank.
- 3) Remove the front panel.
- 4) Carefully pull out the control box.
- 5) Disconnect the wash pump motor wiring at the closed end connectors.
- 6) Disconnect the flexible pipe from the pipe joint.
- 7) Remove the bands and disconnect the wash pump motor from the tank discharge outlet and suction inlet.
- 8) Remove the lower panel mounting screws, loosen the upper screws, and disconnect the wiring from the panel to remove the wash pump motor together with the panel.
- 9) Remove the wash pump motor from the panel.
- 10) Remove the pipe joint from the wash pump motor.

To replace:

Note: Be sure to use new O-rings and gaskets.

- 1) Attach the pipe joint to the wash pump motor.
- 2) Secure the wash pump motor to the panel, and reconnect the wiring.
- 3) Hook the panel on the upper panel mounting screws.
- 4) Make sure the O-rings are in place and attach the wash pump motor to the tank discharge outlet and suction inlet. Secure the connections with the bands.
- 5) Connect the flexible pipe.

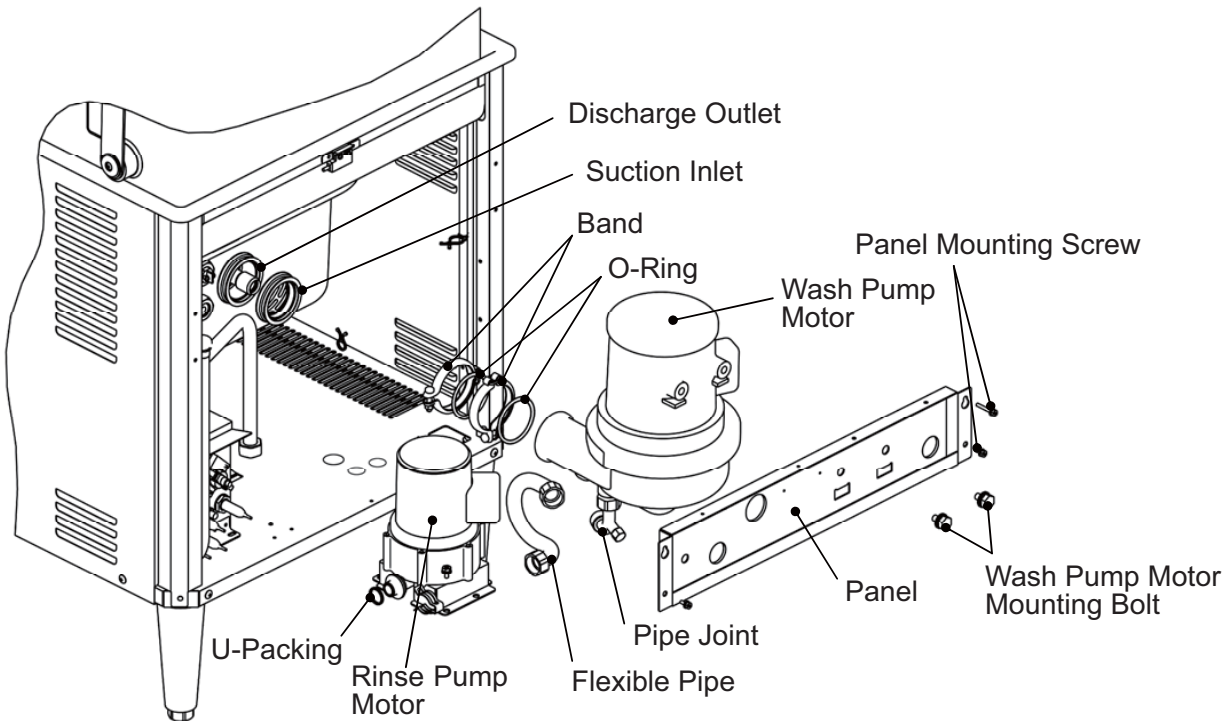

- 6) Fill the tank with water, then check for water leaks from the joints. If there is a water leak, check the connections, and retighten the bands. If there are no water leaks, drain the tank. This inspection cannot detect water leaks from the flexible pipe and pipe joint connection.
- 7) Connect the wiring. When finished, cover the connections with the original plastic sheet cover and secure with a nylon tie. Make sure the connections are situated so that water and condensation cannot reach the connections.
Note: Be careful not to mix up the wire colors. Miswiring will cause reversal of the pump motor, resulting in improper operation.
- 8) Carefully slide the control box into its proper position.
- 9) Replace the front panel.
- 10) Make a trial run, and check for water leaks.

E. Removal and Replacement of Rinse Pump Motor

- 1) Move the power switch (GFCI) to the "OFF" position, then turn off the power supply. Lockout/Tagout to prevent the power from being turned back on inadvertently.
- 2) Remove the front panel.
- 3) Use the internal booster tank drain hose to drain the internal booster tank. **WARNING! To avoid possible burns, allow the internal booster tank water temperature to fall below 104°F (40°C) before draining.**
- 4) Disconnect the rinse pump motor wiring at the closed end connectors.
- 5) Unscrew the internal booster tank rinse pipe, and remove the band from the pipe joint to release the internal booster tank rinse pipe.
- 6) Disconnect the flexible pipe from the rinse pump motor.
- 7) Remove the rinse pump motor.
- 8) To replace, reverse the above procedure.
Note:
 1. Be careful not to mix up the wire colors. Miswiring will cause reversal of the pump motor, resulting in improper operation.
 2. Cover the connections with the original plastic sheet cover and secure with a nylon tie. Make sure the connections are situated so that water and condensation cannot reach the connections.
 3. Be sure to use new O-rings and gaskets.
- 9) Make a trial run, and check for water leaks.

F. Removal and Replacement of Handle

- 1) Unscrew the door link shaft with the door closed. While holding the handle by hand to prevent it from springing back, remove the link arms and related parts from the shaft.

⚠ WARNING

Be sure to hold the handle, or it may spring back and cause injury.

- 2) Remove the screws securing the handle to the arms, and pull off the handle.
Note: A plastic hammer or other tools may be required to pull off the handle.
- 3) To replace, reverse the above procedure.
- 4) Check the door for proper movement.

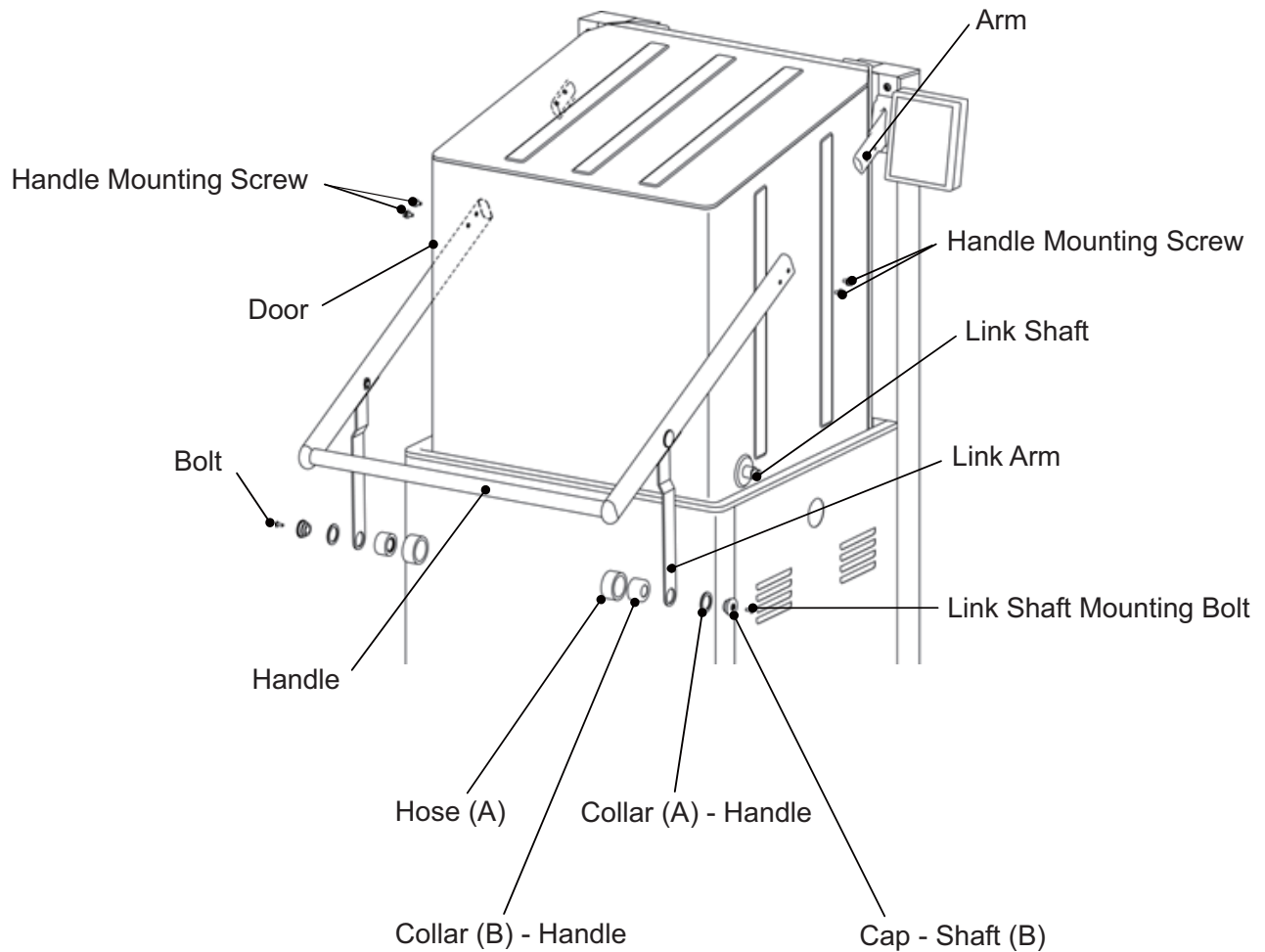

G. Removal and Replacement of Door

To remove:

- 1) Open the door. Remove the lower screws securing the roller units from inside the wash compartment, then loosen the upper screws. **CAUTION! Never remove the upper screws, or the roller units will fall into the rails, and the door cannot be removed. If the roller units should fall into the rails, use a piece of sheet metal with a hooked end or a wire (2 mm dia) with a v-shaped end to pick up the roller units.**
- 2) Remove the water guard (secured with the lower roller unit mounting screws).
- 3) Remove the handle. **WARNING! To reduce the risk of injury, follow the instructions in “IV.F. Removal and Replacement of Handle.”**
- 4) Lift off the door.

To replace:

- 1) Fit the roller units into the rails with the upper mounting screws held in place.
- 2) Position the door into the rails, and fit the door into place. The roller unit and screw positions should be aligned.
- 3) Attach the handle.
- 4) Open the door, reinstall the water guard, and screw the roller units from inside the wash compartment.
- 5) Check the door for proper movement.

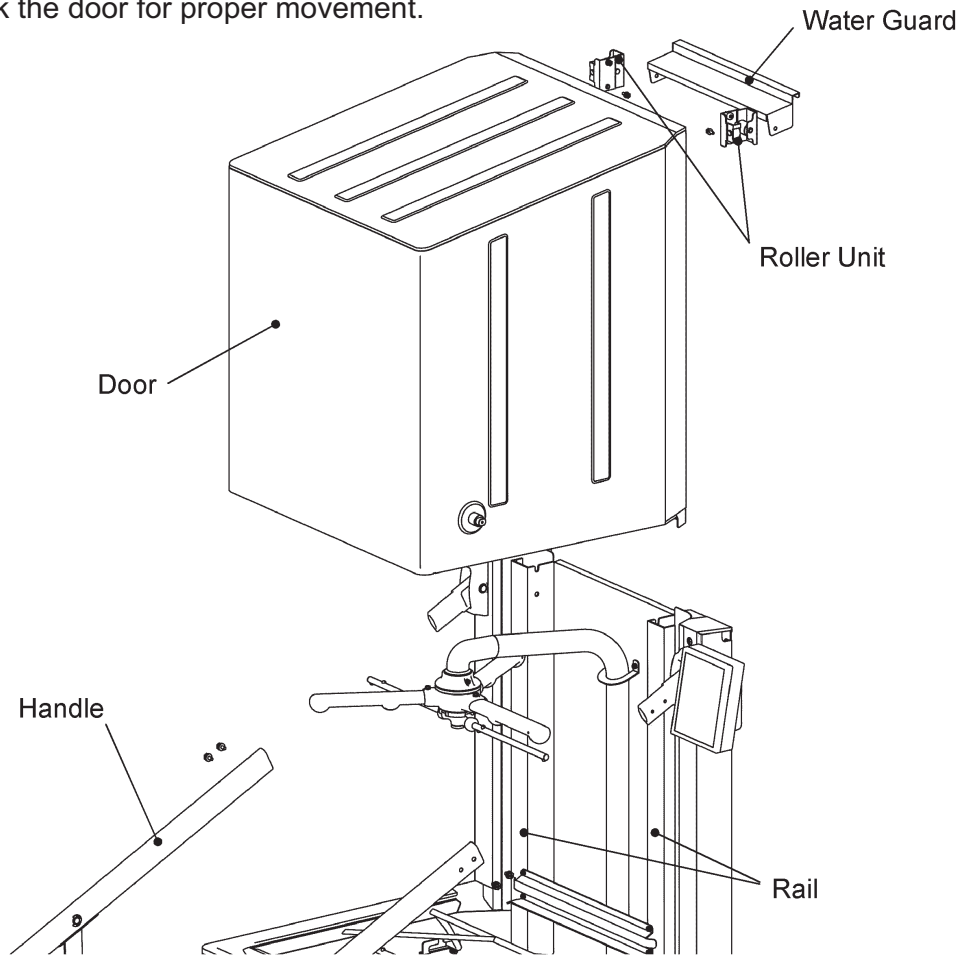

H. Removal and Replacement of Spring Unit

- 1) Remove the handle. **WARNING! To reduce the risk of injury, follow the instructions in “IV.F. Removal and Replacement of Handle.”**
- 2) Remove the frame covers.
- 3) Loosen the spring unit mounting screws, and remove the operation panel.
- 4) Remove the spring unit mounting screws, and lift off the spring units.
- 5) To replace, reverse the above procedure.
- 6) Adjust the door opening/closing force. See “IV.J. Adjustment of Door Opening/Closing Force.”

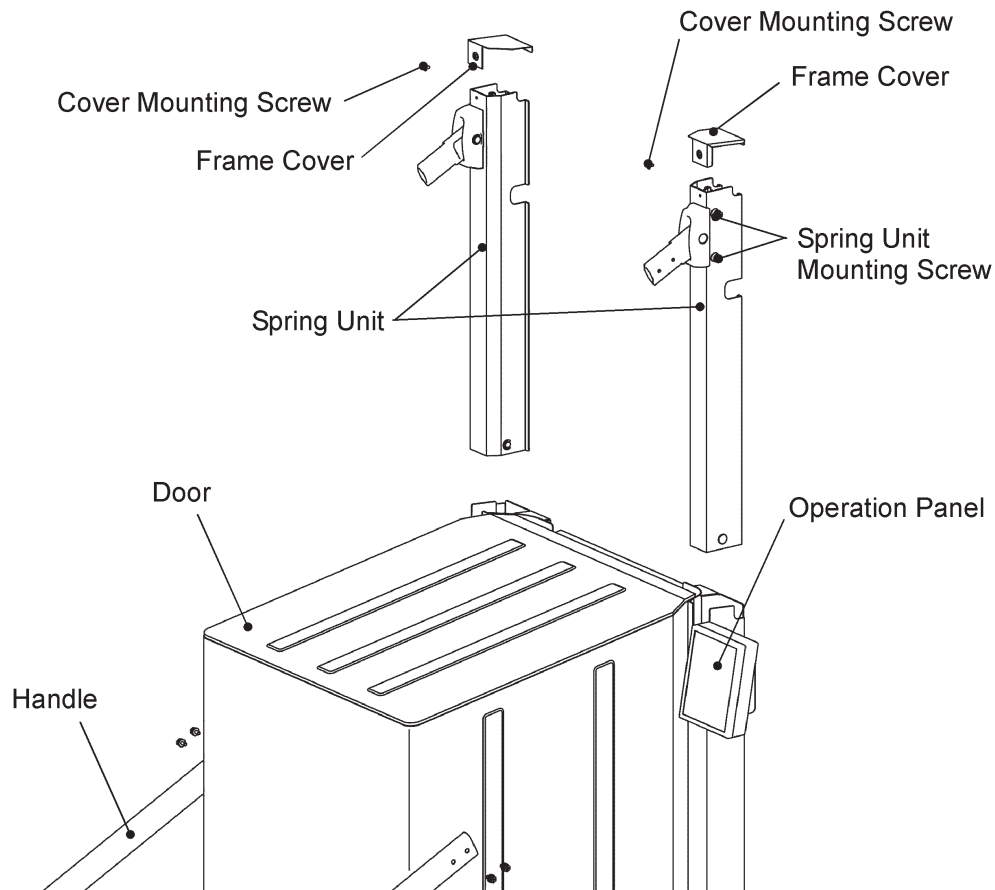

I. Removal and Replacement of Spring

- 1) Remove the spring units. See “IV.H. Removal and Replacement of Spring Unit.”
- 2) Remove the U-nut.
- 3) Use a flat blade screwdriver to turn the spring rod end in the direction for stretching the spring. When the screwdriver cannot turn any more, use a wrench (#8) to turn the spring rod in the same direction as above to remove the arm.
- 4) Remove the casing shaft, and take the spring out of the spring casing.
- 5) To replace, reverse the above procedure.

6) Adjust the door opening/closing force. See “IV.J. Adjustment of Door Opening/Closing Force.”

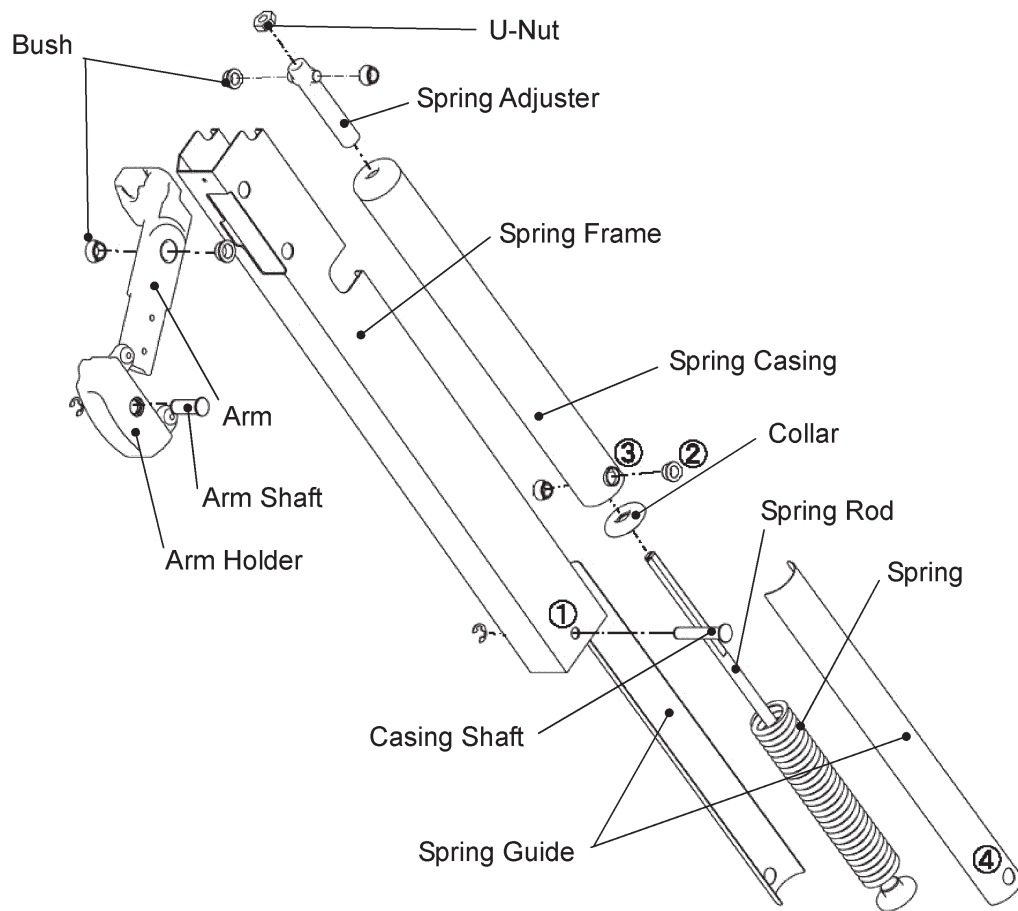

Spring Unit Internal Structure

J. Adjustment of Door Opening/Closing Force

The door opening/closing force is easily adjustable as follows:

- 1) Remove the frame cover.
- 2) Remove the U-nut.
- 3) Rotate the door opening/closing force adjustment screw with a flat blade screwdriver to adjust the spring tension.

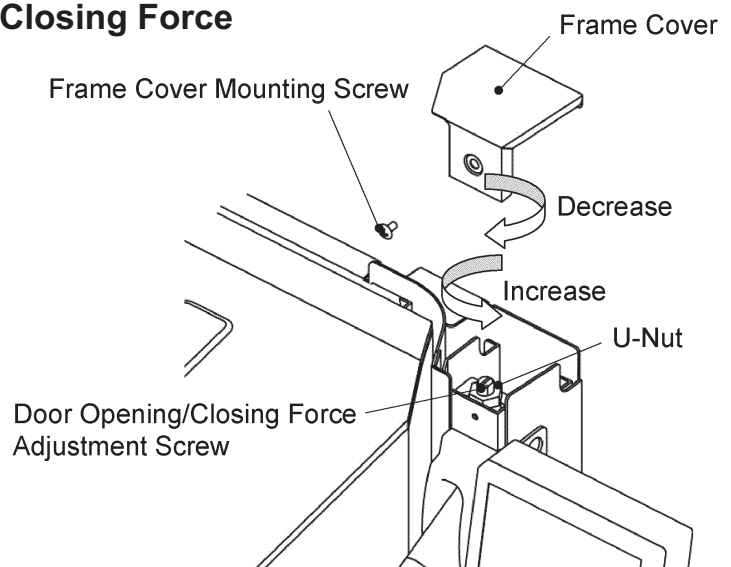

K. Removal and Replacement of Flush Pipe

- 1) Remove the rack rails, upper/lower wash and rinse spray arms, tank filters, overflow pipe, and separator.
 - 2) Remove the rack guide.
 - 3) Remove the band.
 - 4) Remove the upper and lower headers.
 - 5) Unscrew the joint to the pump discharge outlet, then remove the flush pipe.
 - 6) To replace, reverse the above procedure.
- Note: Be sure to use new O-rings and gaskets.
- 7) Make a trial run, and check for water leaks.

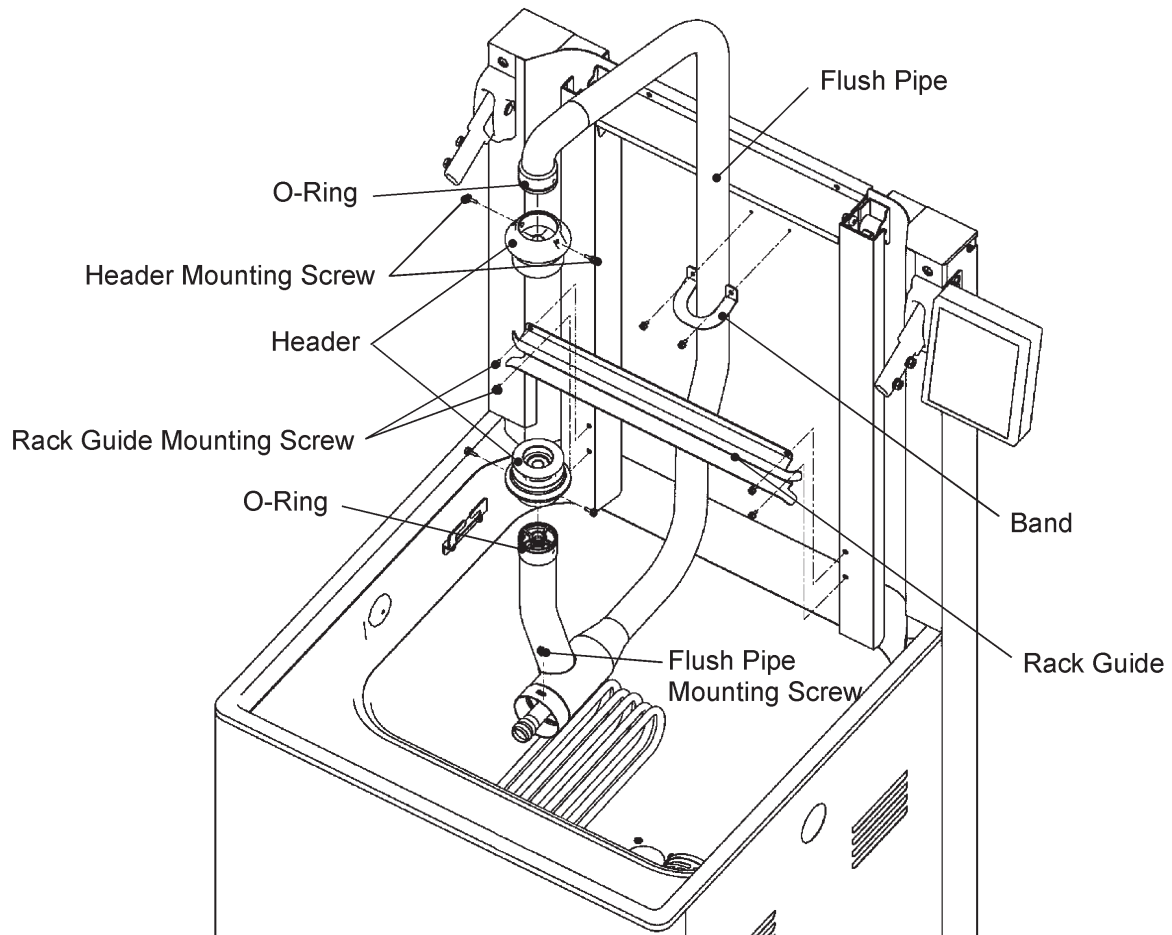

L. U-Packing Installation Instructions

CAUTION

Incorrect installation of the U-packings will cause water leaks.

1) Water Supply Pipe and Rinse Pump Connection

- The pipe is under pressure inside and under atmospheric conditions outside.

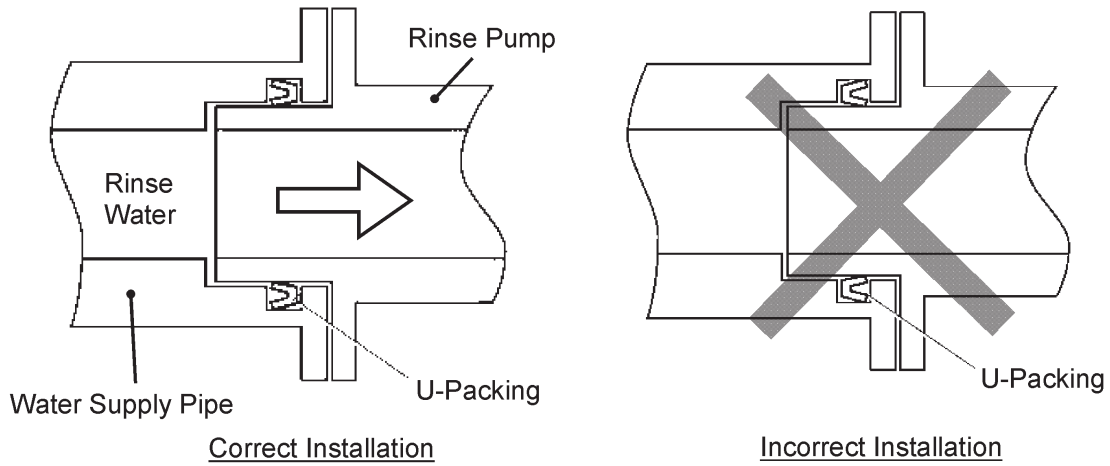

2) Rinse Water Line Connection Inside Double Pipe

- The pipe is under pressure inside and outside.

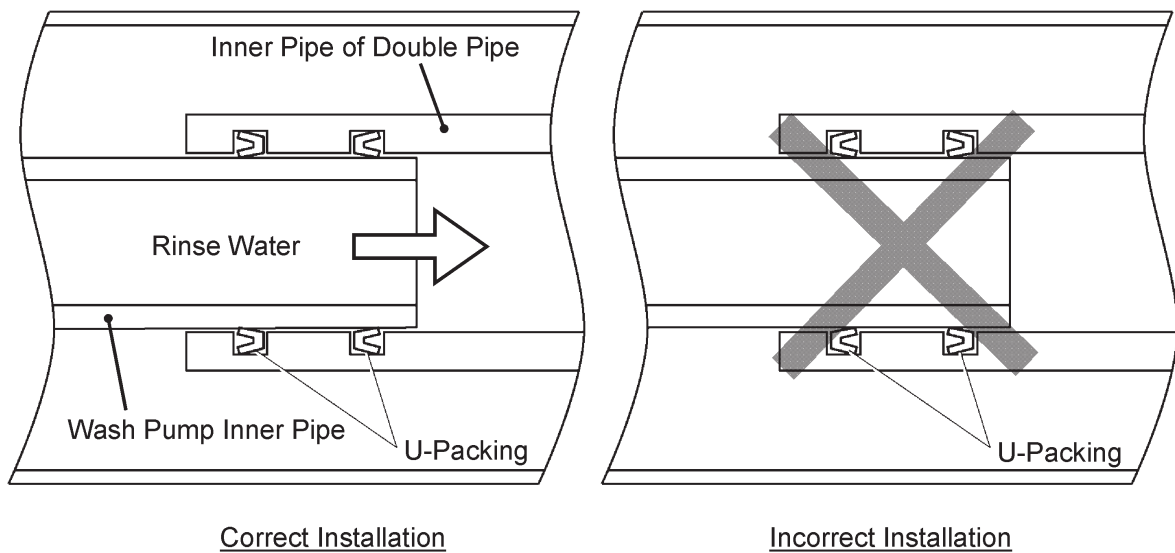

3) Header (Rinse Spray Arm) and Double Pipe Connection

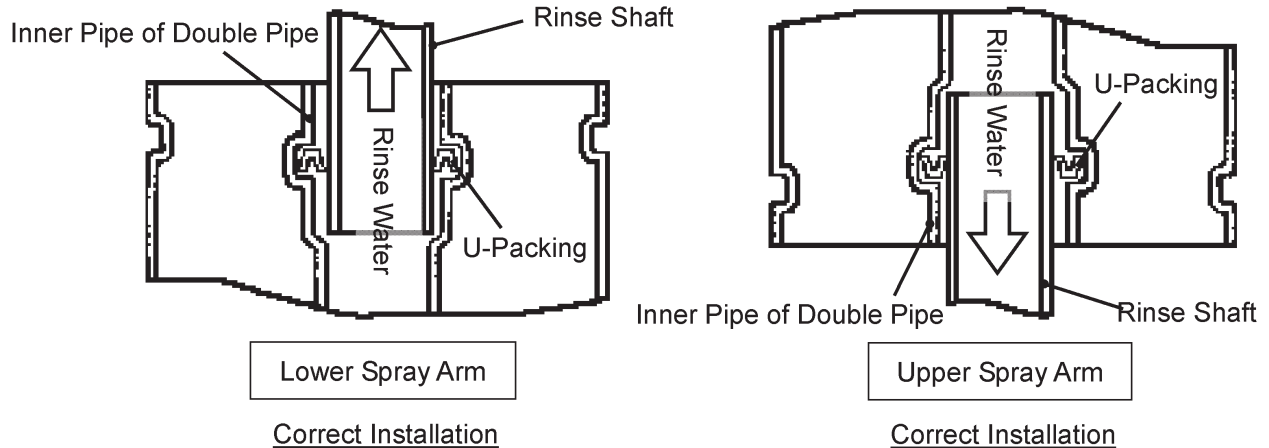

M. Removal and Replacement of Thermistor

CAUTION

1. The thermistors are fragile; handle very carefully.
2. Always use the recommended sealant (high thermal conductive type), Model KE4560RTV manufactured by SHINETSU SILICONE, Part Code 60Y000-11, or Part Code 4A0683-01 or equivalent.
3. Do not shorten or cut the thermistor leads.

- 1) Move the power switch (GFCI) to the "OFF" position, then turn off the power supply. Lockout/Tagout to prevent the power from being turned back on inadvertently.
- 2) Remove the front panel.
- 3) Remove the plastic bag covering the thermistor connector, then disconnect the thermistor connector. If replacing the wash tank thermistor, disconnect the leads from the wash tank electrode. If replacing the internal booster tank thermistor, disconnect the closed end connectors for the internal booster tank water level float switch and the internal booster tank backup water level float switch.
- 4) Remove the tape or ties securing the thermistor leads, then pull out the thermistor from the wash tank or internal booster tank straight towards you.
- 5) Clean out all old sealant from inside the thermistor hole.
- 6) Route the wires from the new thermistor connector through the existing black plastic sleeve.
- 7) Apply the recommended sealant (KE4560RTV, Part Code 60Y000-11 or 4A0683-01) to the end of the new thermistor, then insert the thermistor quickly and securely.
- 8) Use tape or ties to secure the thermistor leads in their correct position.
- 9) Reconnect the thermistor connector and the wash tank electrode leads or the internal booster tank water level float switch and internal booster tank backup water level float switch leads, then bag and tie them.
- 10) Replace the front panel in its correct position.

N. Removal and Replacement of Control Board or Operation Board

When replacing a control board or operation board, follow the precautions below.

CAUTION

1. The control board and operation board are fragile; handle very carefully.
2. The control board and operation board contain integrated circuits, which are susceptible to failure due to static discharge. It is especially important to touch the metal part of the unit when handling or replacing the control board or operation board.
3. Do not touch the electronic devices on the control board or operation board or the back of the control board or operation board.
4. Do not change wiring and connections.
5. Always replace the whole control board or operation board assembly if it goes bad.
6. Do not short out power supply to test for voltage.

1. Control Board

- 1) Move the power switch (GFCI) to the "OFF" position, then turn off the power supply. Lockout/Tagout to prevent the power from being turned back on inadvertently.
- 2) Remove the front panel and the control box cover.
- 3) Disconnect the control board connectors from the control board.
- 4) Remove the 2 screws and the control board.
- 5) Install the new control board.
- 6) To replace, reverse the above procedure.

2. Operation Board

- 1) Move the power switch (GFCI) to the "OFF" position, then turn off the power supply. Lockout/Tagout to prevent the power from being turned back on inadvertently.
- 2) Loosen the 2 mounting screws on the unit frame, then remove the operation panel assembly.
- 3) Remove the screw securing the stay - OP, joint - operation (B), and operation panel (B).
- 4) Disconnect the connector for the operation board cable and the cable - operation.
- 5) Install the new operation board.
Note: Remove the 2.0 mm dia tube (A) from the inside groove of the old board, and attach the tube (A) to the new board.
- 6) To replace, reverse the above procedure.
Note: Make sure the tubes are snug inside the joint - operation (B) and operation panel (B).

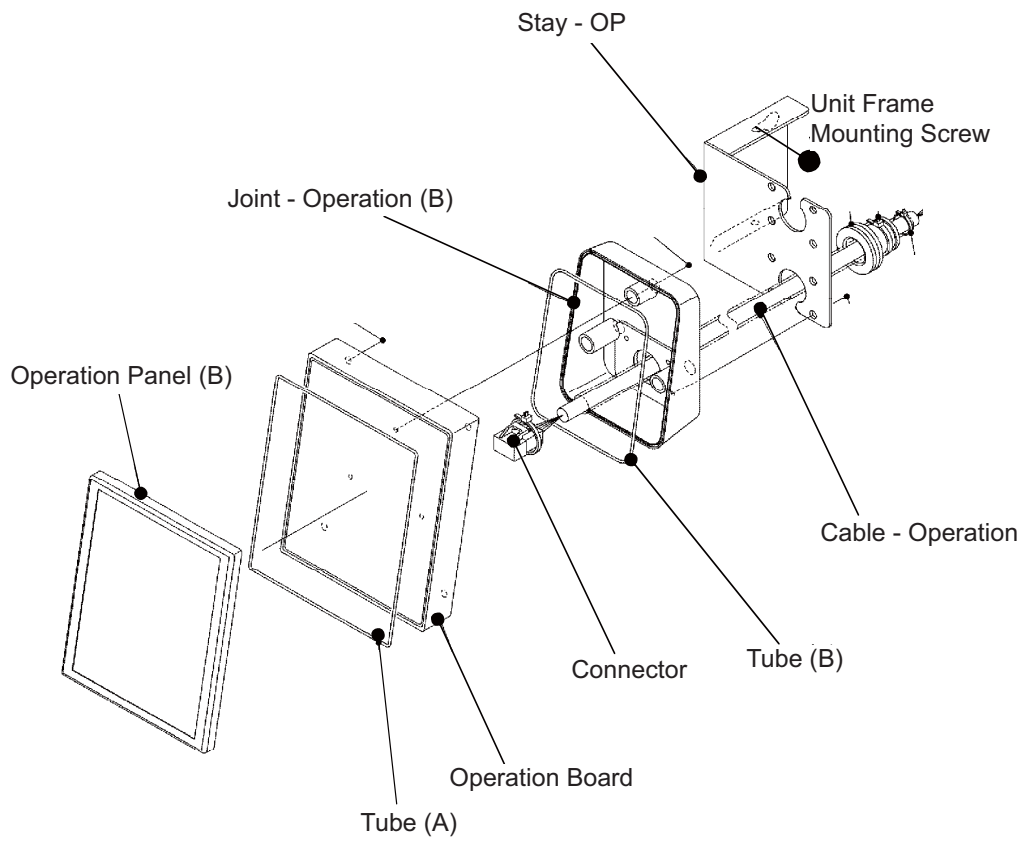

V. Cleaning and Maintenance Instructions

A. Daily Maintenance

IMPORTANT

Be sure to clean the dishwasher after closing time every day. It is difficult to remove heavy soils left overnight. In high temperature conditions, food scraps will rot and affect sanitary operation.

- 1) Take out scraps from the removed tank filters, and wash them clean with a scourer.

IMPORTANT

To prevent damage, do not hit the filters on the sink to drop scraps or to drain the filters.

- 2) Turn and loosen the upper spray arm nut in the direction of the arrow. Support the upper rinse spray arm, and remove it together with the upper wash spray arm.

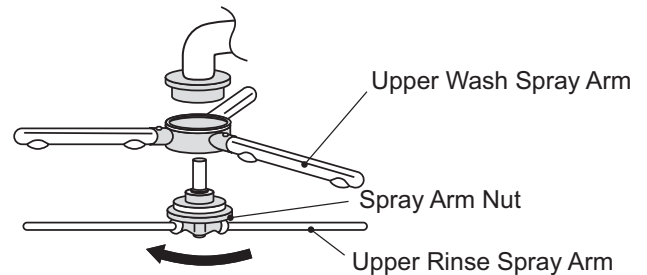

- 3) Turn and loosen the lower spray arm nut in the direction of the arrow. Lift off the lower rinse spray arm, and remove the lower wash spray arm.

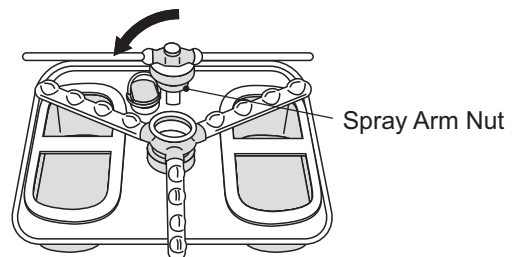

- 4) If the wash spray arm and rinse spray arm nozzles are clogged, use a wire or brush to unclog and wash them clean.

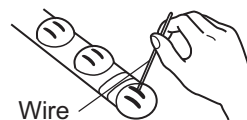

- 5) Clean the wash compartment by lifting off the separator toward you. Remove any scraps from inside the wash compartment and wash tank. Use a scourer to wash off heavy soils.

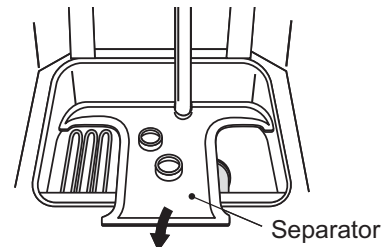

IMPORTANT

To prevent damage, do not hit the separator on the sink to drop scraps or to drain the separator.

6) Check the pump filter inside the wash tank. If it is clogged, clean it with a scourer.

7) Check the water level sensor. If it is dirty, clean it with a soft brush.

Water Level Sensor Location

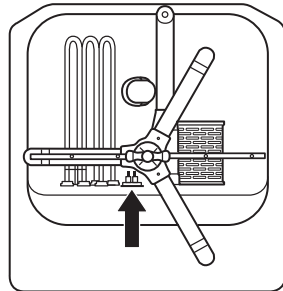

Front

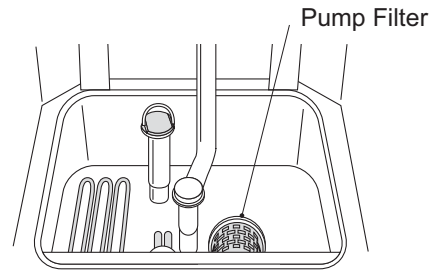

Water Level Sensor

IMPORTANT

Do not use a metal brush to clean the water level sensor. The surfaces may be damaged, or metal particles attached to the sensor may cause malfunction.

8) Replace the separator in its correct position.

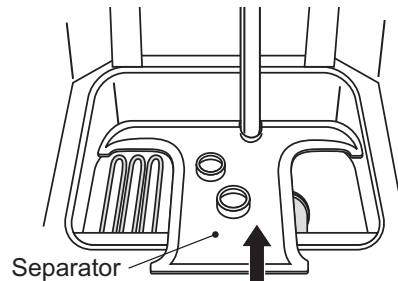

9) Install the left and right tank filters.

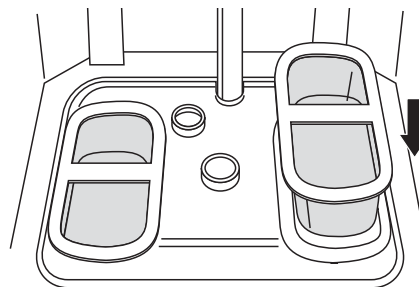

10) Use one hand to hold the upper wash spray arm on the upper spray arm shaft, and use the other hand to tighten the upper spray arm nut in the direction of the arrow.

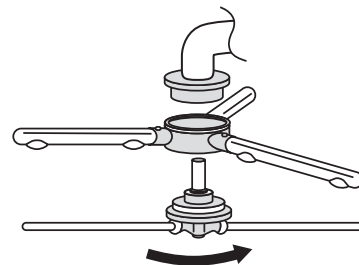

- 11) Place the lower wash spray arm on the lower spray arm shaft, and tighten the lower spray arm nut in the direction of the arrow.
- 12) Check that the wash spray arms and rinse spray arms can be turned easily by hand.

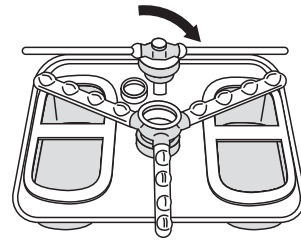

- 13) Insert the drain pipe securely.

Insert Drain Pipe securely

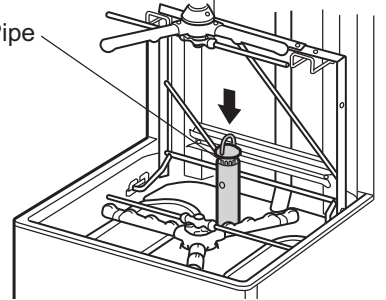

- 14) Lower the rack rail. With the rack rail lifted up, the door cannot be closed and the unit will not operate.

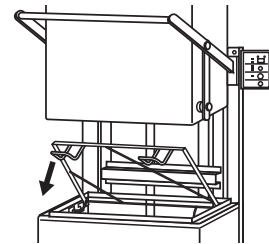

B. Self-Cleaning

The self-cleaning function is to rinse the wash compartment with hot water. Use this function after step 7) of “V.A. Daily Maintenance.”

CAUTION

If a portion control detergent feeder other than concentration sensitive type is used, turn off the power to the detergent feeder. Otherwise the detergent may be supplied during the self-cleaning cycle. After the cycle completes, turn the detergent feeder back on. If this is not practical, consult with an authorized Hoshizaki service company.

- 1) Turn on the gas and water supplies and water heater.
- 2) Pull out the drain pipe.

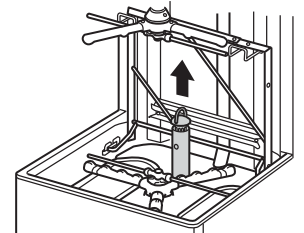

- 3) Install the upper and lower rinse spray arms only, and lower the rack rail. With the rack rail lifted up, the door cannot be closed and the unit will not operate.
- 4) With the door open, move the power switch (GFCI) to the “ON” position, then press and hold the “STANDBY/CLEANING” button for 3 seconds. “SC” appears in the display.

Upper Rinse Spray Arm

Rack Rail

Lower Rinse Spray Arm

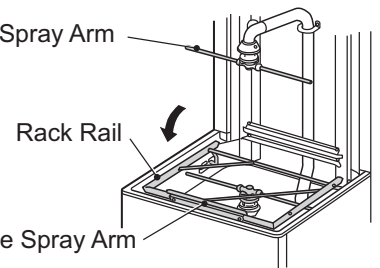

- 5) Close the door. "SC" and the "AUTO FILL" lamp start flashing, and the self-cleaning cycle begins. The buzzer sounds and the operation panel turns off when the cycle ends. Move the power switch (GFCI) to the "OFF" position. Turn off the water heater, and the gas and water supplies.
- 6) Open the door, and remove the upper and lower rinse spray arms. Go on to step 8) of "V.A. Daily Maintenance."

C. Weekly Maintenance

1. Heater

⚠ WARNING

To prevent burns, wait for 10 minutes after draining the unit to clean the interior.

Remove any scraps from the heater, and use a soft brush to wash off residue.

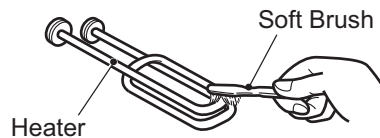

Do not use a metal brush which may damage the surface.

2. Exterior

- 1) Wipe the exterior with a soft cloth.
- 2) Use a damp cloth containing a neutral cleaner to wipe off dirt. Then wipe away the residue with a clean cloth.

3. Wash Compartment

- 1) Tilt back the rack rail, and lift it off the notch.
- 2) Remove any scraps from the wash tank.

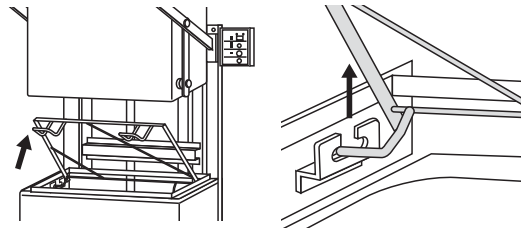

D. Monthly Inspection

1. Power Switch (Ground Fault Circuit Interrupter)

- 1) Open the cover at the front, and move the power switch (GFCI) to the "ON" position.
- 2) Press the test switch. The power switch (GFCI) should switch from "ON" to "OFF".
- 3) If not, move the power switch (GFCI) to the "OFF" position, and contact an authorized Hoshizaki service company.

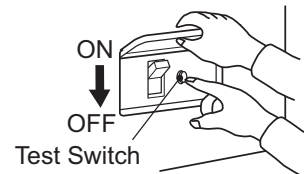

2. Water Supply Line

Check the water supply line for damage, deformation, or water leak marks (stains). If any of these conditions are found, contact an authorized Hoshizaki service company.

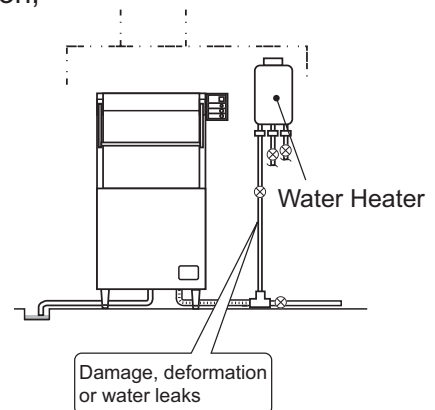

Recommendation of safety inspection by service personnel

Even if there is no problem with its use, a product out of warranty may have a risk of electric shock, fire, or water leak due to insulation degradation or aging of the electrical parts. Ask an authorized Hoshizaki service company for the following inspections (charged):

- Dust and dirt build-up or water leak inside the unit
- Aging conditions of the unit and its components
- Scale, silica, lime or other foreign matter in the water circuit

E. Descaling (As Required)

Use a descaler according to the supplier's instructions.

▲ WARNING

1. Carefully follow any instructions provided with the descaler.
2. Always wear liquid-proof gloves and goggles to prevent the descaler from coming into contact with skin or eyes.
3. To prevent generation of toxic chlorine gas, do not mix a descaler with a chlorinated cleaner.

- 1) Pull out the drain pipe to drain water from the wash tank. Start the auto fill cycle to fill the wash tank with hot water.
- 2) Use the "ON/OFF" button to turn off the unit. Refer to the descaler's directions and add the proper amount of descaler to the wash tank. The wash tank holds 14.3 gallons of water.
- 3) Keep the door open. Press and hold the up and down buttons and the "MODE" button, then press the "ON/OFF" button to select the "PC" (Preventative Cleaning) mode.
- 4) Close the door to start preventative cleaning.
- 5) Refer to the descaler's directions for the proper duration of cleaning. When the proper amount of time has passed, press the "ON/OFF" button to stop cleaning.
- 6) Open the door, then check the wash tank interior. Repeat steps 1) through 5) if necessary.

▲ WARNING

Be careful not to burn yourself with the hot water or parts in the wash tank.

- 7) Drain the wash tank, then start the auto fill cycle. Run the dishwasher to rinse the wash tank thoroughly. Drain the wash tank.

F. Shutdown

CAUTION

If there is a possibility that the ambient temperature may fall below 32°F (0° C) and freeze the unit, be sure to drain the unit. The water supply line could be damaged and leak water, resulting in damage to the surrounding property.

To drain out the water heater, close the water supply line shut-off valve, and open the drain valve and water supply valve.

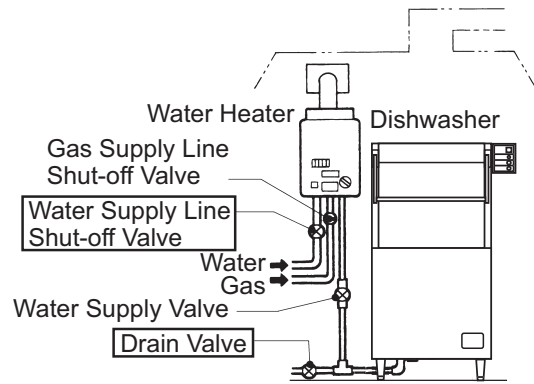

- 1) Press the “ON/OFF” button on the operation panel. The display and lamps go off.
- 2) Open the cover in the front panel, then move the power switch (GFCI) to the “OFF” position.
- 3) Turn off the water heater.
- 4) Turn off the gas and water supplies.

IMPORTANT

To operate the water heater, follow its instruction manual.

- 5) Tilt back the rack rail.

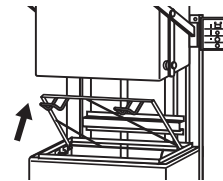

IMPORTANT

The rack rail may fall down if tilted more than 10°. Do not hang anything from it or hit it hard.

- 6) Pull out the drain pipe to drain water from the wash tank.

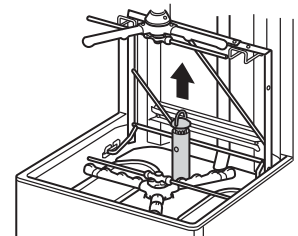

WARNING

When pulling out the drain pipe, be careful not to touch the wash water. It may cause burns or skin irritation. Turn the drain pipe if it is hard to pull out.

- 7) Remove the right tank filter and then the left tank filter without spilling scraps inside.

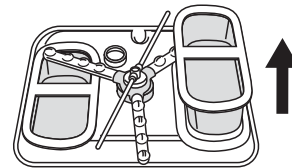

G. Long Storage, Relocation, Disposal, Transfer

When preparing the unit for long storage, shut down and clean the unit according to sections A - F. Move the power switch (GFCI) to the “OFF” position and turn off the power supply.

If something seems wrong when restarting the unit after long storage, turn off the power supply, and immediately contact an authorized Hoshizaki service company.

⚠ WARNING

1. When restarting the unit after long storage, contact an authorized Hoshizaki service company. To prevent electric shock, do not restart the unit by yourself.
2. In case of relocation, contact an authorized Hoshizaki service company. Improper installation may cause water leak, electric shock or fire.
3. When disposing of the unit, contact an authorized Hoshizaki service company. Leaving the unit may violate laws or cause an unexpected accident.

CAUTION

When selling or transferring this product, tape the instruction manual and the installation manual to the exterior to provide the new owner with information on safe and proper use of the product.

VI. Operating Instructions

CAUTION

Do not stack racks. Otherwise, this will cause reduction in the washing effect or failure.

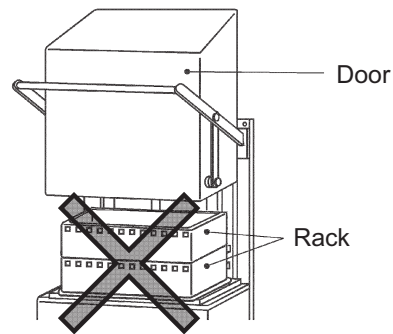

- Before loading dishes in the rack, be sure to remove any leftovers (ex. meat, fish, vegetables), chopsticks, toothpicks, sticks, straws, paper products and plastics from the dishes. They may clog the piping and wash pump, resulting in reduction of washing performance or pump failure.
- Install the separator and tank filters without creating a large gap at the tank overlap. Do not bang the tank filters and separator to clean or drain, or they may be deformed. Leftovers and other foreign matter may enter the tank and clog the piping and wash pump, resulting in reduction of washing performance or pump failure.
- Insert the drain pipe (overflow pipe) after installing the separator. The separator may rise up to create a large gap at the tank overlap. Leftovers and other foreign matter may enter the tank and clog the piping and wash pump, resulting in reduction of washing performance or pump failure.
- After closing time, always clean the tank filters, wash/rinse spray arms and water level sensor. When disassembling the spray arms, check and remove any leftovers clogging the pipe joints. Otherwise the leftovers may become hard to remove or spoil.
- Read the instruction manual carefully to ensure safe and proper operation.

VII. Technical Information

A. Water Circuit

Water Circuit in Connection with Electric Booster

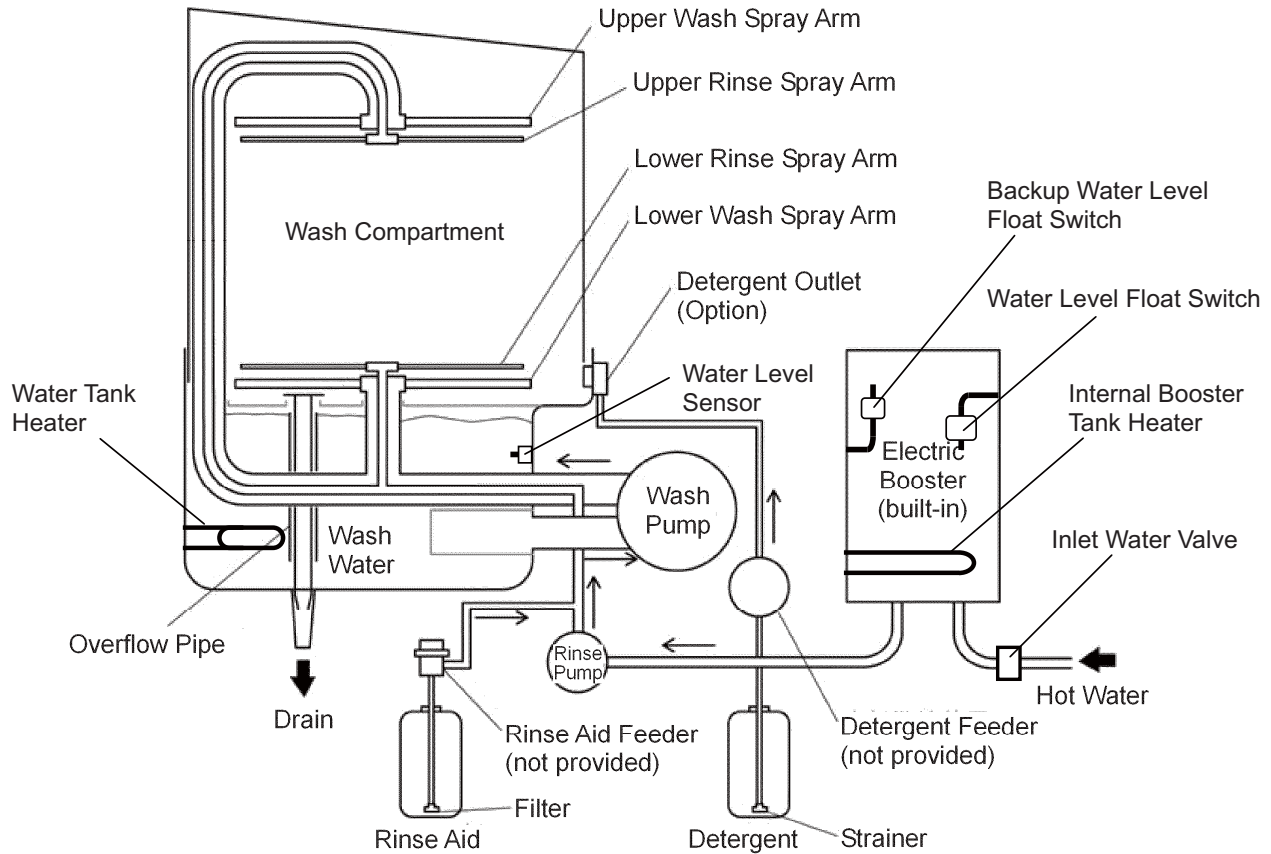

- The wash water is sprayed by the wash pump from the upper and lower wash spray arms into the wash compartment.
- The rinse water is sprayed by the rinse pump from the upper and lower rinse spray arms into the wash compartment.
- The detergent is fed by the detergent feeder (not provided by Hoshizaki) through the detergent outlet (not provided by Hoshizaki) into the wash tank.
- The rinse aid is fed by the rinse aid feeder (not provided by Hoshizaki) into the rinse water line and sprayed from the upper and lower rinse spray arms into the wash compartment.

B. Wiring Diagram

