

Ice-O-Matic[®]

Service Manual GEMU090 Series



Ice-O-Matic Parts and Labor Domestic & International Limited Warranty

Mile High Equipment LLC (the "Company") warrants Ice-O-Matic brand ice machines, ice dispensers, remote condensers, water filters, and ice storage bins to the end customer against defects in material and factory workmanship for the following:

<ul style="list-style-type: none"> • Cube ice machines, compressed ice machines and remote condensers. - Thirty-six (36) months parts and labor 	<ul style="list-style-type: none"> • Ice storage bins -Twenty-four (24) month parts and labor
<ul style="list-style-type: none"> • Flake ice machines, GEMD Maker Dispensers, and GEMU Undercounter compressed ice machines - Twenty-four (24) months parts and labor 	<ul style="list-style-type: none"> • IOD model dispensers - Twenty-four (24) months parts, Twelve (12) months labor
<ul style="list-style-type: none"> • CD model dispensers - Thirty-six (36) months parts and labor 	<ul style="list-style-type: none"> • Water filter systems - Twelve (12) months parts and labor (not including filter cartridges)

An additional twenty-four (24) month warranty on parts (excluding labor) will be extended to all cube ice machine evaporator plates and all cube ice and compressed ice machines, except GEMU machines, compressors from the date of original installation. An additional thirty-six (36) month warranty on parts (excluding labor) will be extended to all flake ice machine and GEMD maker dispenser compressors from the date of original installation. The company will replace EXW (Incoterms 2000) the Company plant or, EXW (Incoterms 2000) the Company-authorized distributor, without cost to the Customer, that part of any such machine that becomes defective. In the event that the Warranty Registration Card indicating the installation date has not been returned to Ice-O-Matic, the warranty period will begin on the date of shipment from the Company. Irrespective of the actual installation date, the product will be warranted for a maximum of seventy-two (72) months from date of shipment from the Company.

ICE-model cube ice machines which are registered in the Water Filter Extended Warranty Program will receive a total of eighty-four (84) months parts and labor coverage on the evaporator plate from the date of original installation. Water filters must be installed at the time of installation and registered with the Company at that time. Water filter cartridges must be changed every six (6) months and that change reported to the Company to maintain the extended evaporator warranty.

No replacement will be made for any part or assembly which (I) has been subject to an alteration or accident; (II) was used in any way which, in the Company's opinion, adversely affects the machine's performance; (III) is from a machine on which the serial number has been altered or removed; or, (IV) uses any replacement part not authorized by the Company. This warranty does not apply to destruction or damage caused by unauthorized service, using other than Ice-O-Matic authorized replacements, risks of transportation, damage resulting from adverse environmental or water conditions, accidents, misuse, abuse, improper drainage, interruption in the electrical or water supply, charges related to the replacement of non-defective parts or components, damage by fire, flood, or acts of God.

This warranty is valid only when installation, service, and preventive maintenance are performed by a Company-authorized distributor, a Company-authorized service agency, or a Company Regional Manager. The Company reserves the right to refuse claims made for ice machines or bins used in more than one location. This Limited Warranty does not cover ice bills, normal maintenance, after-install adjustments, and cleaning.

Limitation of Warranty

This warranty is valid only for products produced and shipped from the Company after March 1, 2010. A product produced or installed before that date shall be covered by the Limited Warranty in effect at the date of its shipment. The liability of the Company for breach of this warranty shall, in any case, be limited to the cost of a new part to replace any part, which proves to be defective. The Company makes no representations or warranties of any character as to accessories or auxiliary equipment not manufactured by the Company. **REPAIR OR REPLACEMENT AS PROVIDED UNDER THIS WARRANTY IS THE EXCLUSIVE REMEDY OF THE CUSTOMER. MILE HIGH EQUIPMENT SHALL NOT BE LIABLE FOR ANY INCIDENTAL OR CONSEQUENTIAL DAMAGES FOR BREACH OF ANY EXPRESS OR IMPLIED WARRANTY ON THIS PRODUCT. EXCEPT TO THE EXTENT PROHIBITED BY APPLICABLE LAW, ANY IMPLIED WARRANTY OR MERCHANTABILITY OR FITNESS FOR A PARTICULAR PURPOSE ON THIS PRODUCT IS LIMITED IN DURATION TO THE LENGTH OF THIS WARRANTY.**

Filing a Claim

All claims for reimbursement **must be received at the factory within 60 days from date of service** to be eligible for credit. **All claims outside this time period will be void.** The model, the serial number and, if necessary, proof of installation, must be included in the claim. Claims for labor to replace defective parts must be included with the part claim to receive consideration. Payment on claims for labor will be limited to the published labor time allowance hours in effect at the time of repair. The Company may elect to require the return of components to validate a claim. Any defective part returned must be shipped to the Company or the Company-authorized distributor, transportation charges pre-paid, and properly sealed and tagged. The Company does not assume any responsibility for any expenses incurred in the field incidental to the repair of equipment covered by this warranty. The decision of the Company with respect to repair or replacement of a part shall be final. No person is authorized to give any other warranties or to assume any other liability on the Company's behalf unless done in writing by an officer of the Company.

GOVERNING LAW

This Limited Warranty shall be governed by the laws of the state of Delaware, U.S.A., excluding their conflicts of law principles. The United Nations Convention on Contracts for the International Sale of Goods is hereby excluded in its entirety from application to this Limited Warranty.

GEMU090
Service
GEM090 service

This section contains information for the service and repair of the GEMU090 ice machine.

Service Table of Contents

GEM090 service	Page 1
Components:	Page 2
Evaporator and Auger.	Page 3
Control System	Page 4
Water System	Page 5
Storage	Page 6
Performance and Technical Specs	Page 7
Electrical Sequence.	Page 8
Service Diagnosis	Page 9
Service Diagnosis	Page 10
Component Diagnostics.	Page 11
Ice Capacity	Page 12
Removal and Replacement	Page 13
GEMU090 Gearbox Access & Removal	Page 14
Water Seal Replacement	Page 16
Evaporator Replacement	Page 18
Drain Pump (if equipped)	Page 19
Compressor replacement.	Page 20
Bin and Cabinet	Page 21

GEMU090

Service

Components:

- Refrigeration system, including air cooled condenser, compressor, capillary tube and evaporator.
- Control system, including ice level sensor, water sensor, auger motor sensor, controller, control pad and transformer.
- Auger drive system, including auger motor, gear reducer and auger.
- Auger support system, including top bearing and water seal.
- Water system, including the float and reservoir.
- Storage system, including ice storage bin, drain and door.

During ice making the refrigeration system takes heat from the evaporator. The evaporator is a vertical refrigerated stainless steel tube containing water and a slowly rotating auger. When the water gets to the freezing point, ice begins to form. That ice is very soft and is pushed up the evaporator tube by the auger. As ice is made more warm water enters at the bottom. The soft, mushy ice is forced up to the top of the evaporator's tube where it is forced through nine tapered holes. As the ice is pushed through the holes excess water is squeezed out. The ice comes out of the holes shaped as a rod of ice. The rods of ice are broken off by being pushed against the tapered flange above the holes, forming the irregular lengths of pearl ice. The ice sweep, rotating with the auger, moves the ice to the ice chute where it falls by gravity into the storage bin.

The GEMU090 is a continuous flow ice machine. When the control system senses that the storage bin's ice level is low, it turns on the compressor, fan motor and auger drive motor.

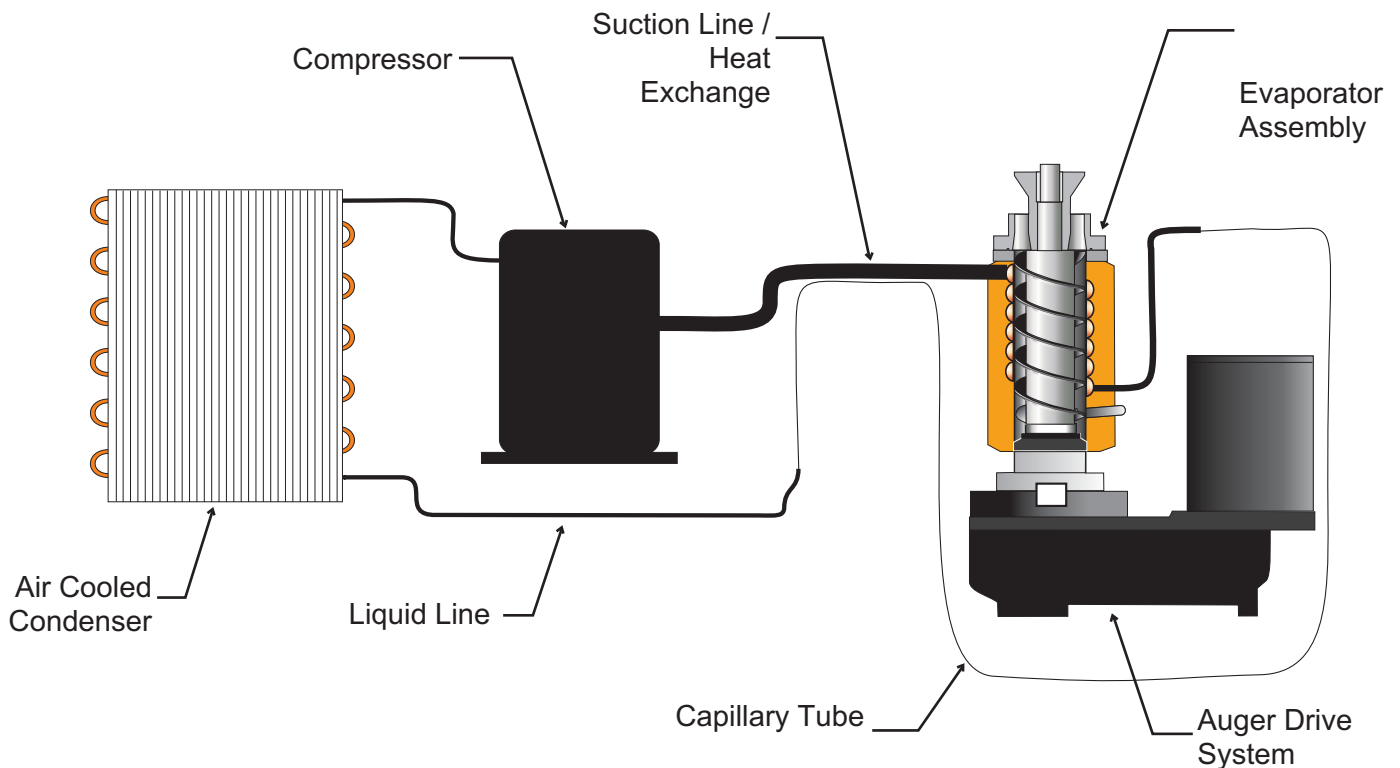

Refrigeration System Schematic

GEMU090
Service
Evaporator and Auger

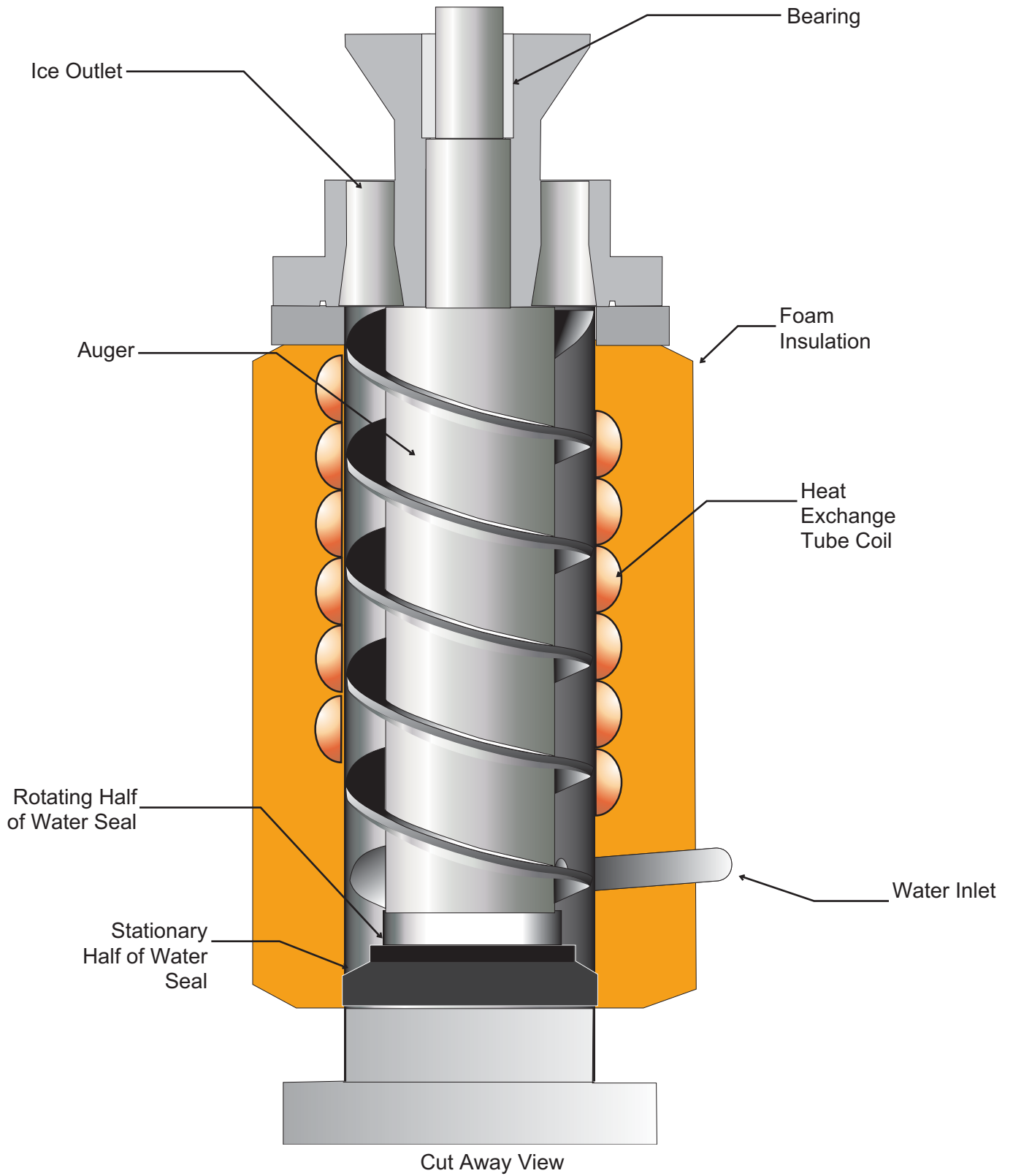

GEMU090

Service

Control System

The control system operates the machine. The controller operates on 12 volts AC, supplied by the transformer. It uses an ultrasonic ice sensor to measure ice level. The ultrasonic system transmits sound waves into the ice storage bin and measures the return time, when the return time is longer than the preset time for bin full, the controller switches the ice machine to an ice making mode. During ice making the compressor, fan motor and auger motor are operating.

The control system has two safeties: It will not operate the machine without water and it will not operate the machine if the auger motor is drawing too much current or if it isn't drawing any current. The water sensor is checking the conductivity of the water in the water reservoir. If there is no water in the reservoir the conductivity will be zero and the controller will either not start ice making or will stop making ice.

The current or amps of the auger motor are continually monitored by the controller during ice making. If the current is too high, indicating an overload, the controller will stop ice making. If the current is zero, indicating an auger motor failure, the controller will also stop ice making.

The control pad has two switches and three lights. The left switch button is On/Off. The right switch button is Clean/Reset. The left Ice Making light is a status light, it is ON when the machine has been switched to an ice making mode. The center light is a Water light, it will be ON when the controller has sensed that there is no water available. It will go out when the water supply has been restored. The right light is a Time to Clean indicator light. It is switched ON by the controller after six months of power connect time. It will go out after the machine has been cleaned following the process in the Maintenance section.

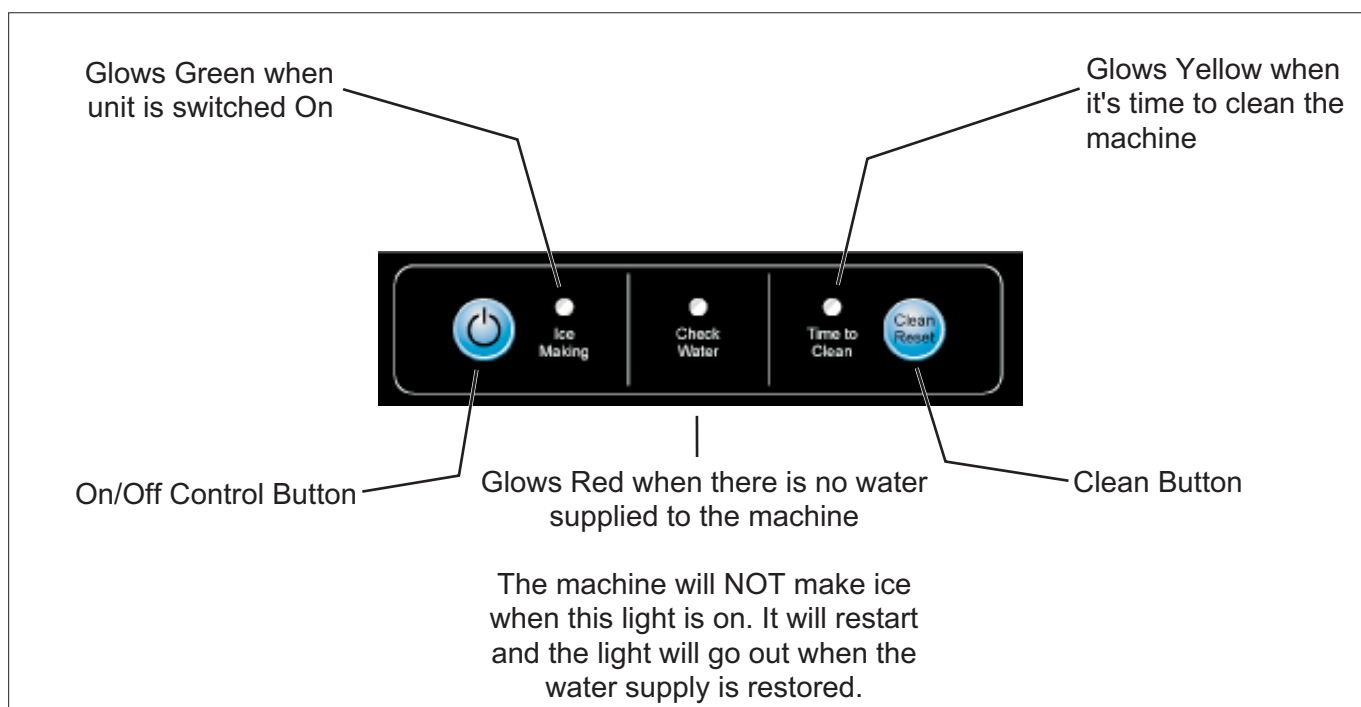

Control Panel

GEMU090

Service

Water System

The auger is driven at about 11 RPM by the gear reducer. The gear reducer is a sealed component and does not require lubrication, as it contains a charge of grease. The auger motor drives a set of gears that all together reduce the motor speed to the 11 RPM output speed and correspondingly increasing the torque. The output shaft of the gear reducer is hollow to accept the square end of the auger.

The auger is one of the key components in this product. It is a precision machined part cut from solid stainless steel bar stock. It fits the inside of the evaporator tube very closely and is aligned by the gear reducer at the bottom and a self lubricating bearing at the top.

As ice is made and forced up the evaporator, the auger is being pushed down. That thrust is supported by the bearings in the gear reducer. Those bearings also provide alignment for the bottom of the auger, keeping it centered in the evaporator tube. The top bearing provides auger alignment at the top.

Water is kept from leaking out the bottom of the evaporator by the water seal. The water seal is the type of seal called a face seal, with the outside diameter of a stationary half pressed against the inside of the evaporator tube and a rotating half attached to the bottom of the auger. The sealing action takes place where the faces of the two halves rub together.

Water is the raw ingredient of ice and it enters this machine through the compression fitting in the back. That leads to the float valve and reservoir. When the float is not supported by water, the float arm is down and the attached float valve is open. As water enters the reservoir, it also flows into the reservoir's outlet tubing which leads to the evaporator water inlet, filling the evaporator. The float rises as the water level is increased until it has lifted high enough to force the water valve to close, stopping the flow of water. When the machine is making ice, the water level will drop

slightly and water will flow into the reservoir through the partially open float valve. It will flow in continually as ice is made.

Water quality. Nearly all water supplies contain some impurities or minerals. When ice is made those minerals can remain behind in the ice machine and coat its surfaces with a hard, stone like substance known as scale. This scale must occasionally be removed by scale remover. Scale remover is a food grade acid that will dissolve the scale so it can be washed away. Note: it is important to ALWAYS dilute the scale remover when using it on this machine. Never use undiluted scale remover.

Some water treatment devices make very clean water, Reverse Osmosis is one of those and this machine may be used with RO water as long as the conductivity is greater than 10 microsiemens/cm. Use of de-ionized water is not recommended and will void the warranty.

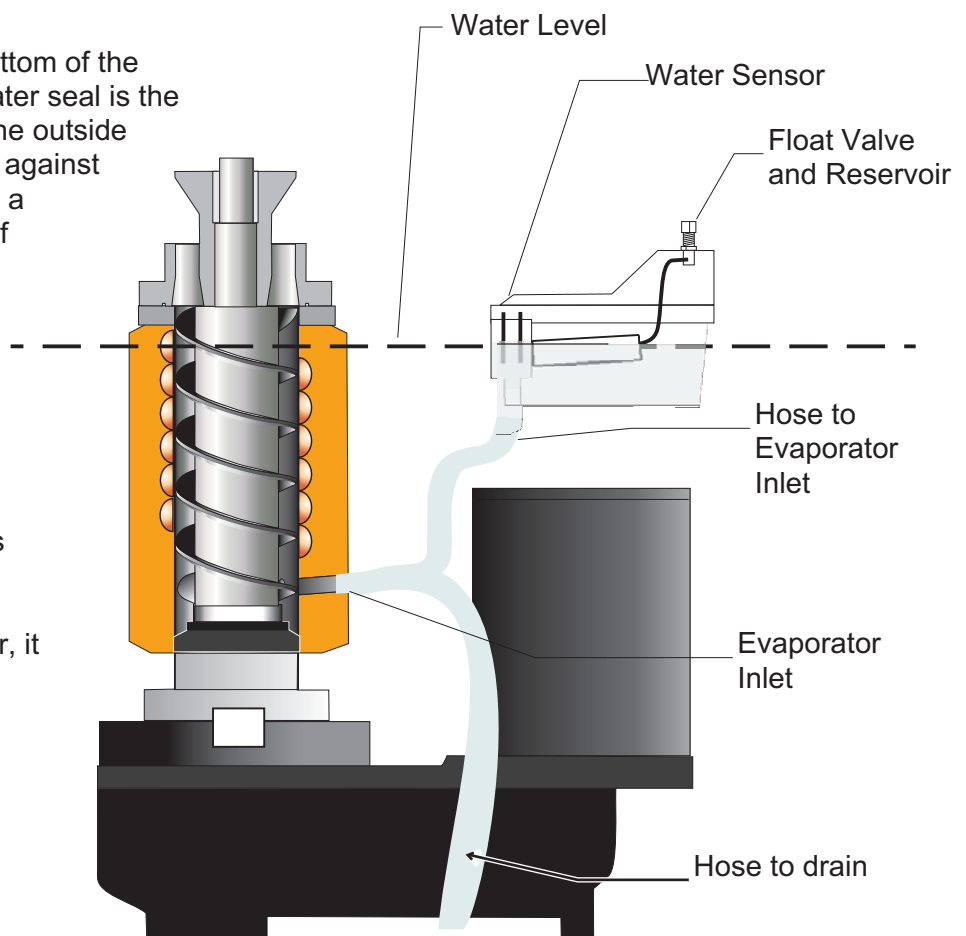

GEMU090

Service

Storage

The ice storage system is made up of a plastic lined ice storage bin, covered by an insulated top panel and an insulated swing open door with gasket. The ice storage bin is foamed in place, so the side panels are not removable.

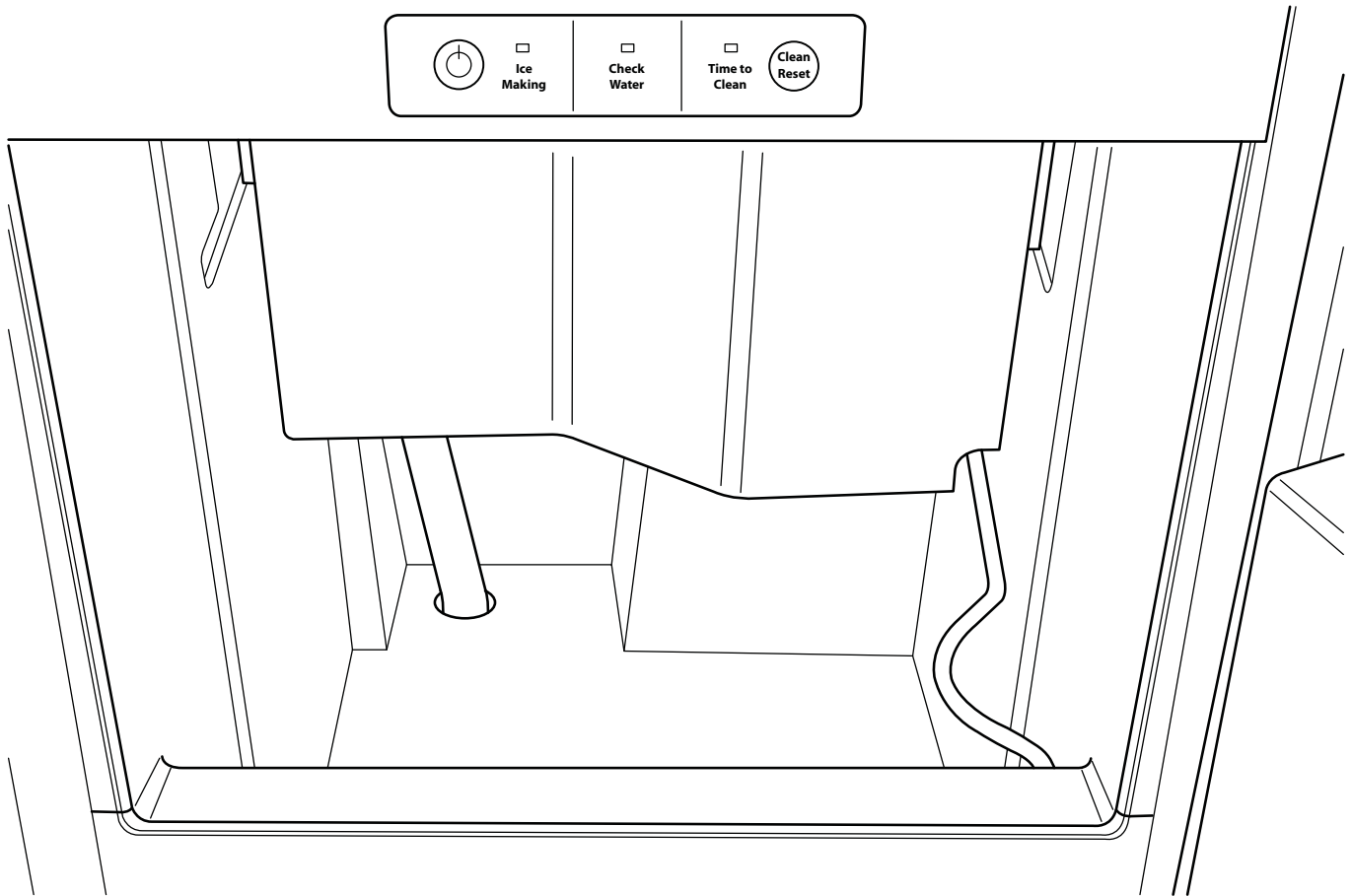

GEMU090

Service

Performance and Technical Specs

Overall:

- Refrigerant: 4.5 oz R-134a
- Compressor: Hermetic, 1390 BTUH
- Condenser: Forced draft
- Fan blade: 3 blade, 6 inch
- Evaporator: Stainless steel tube, copper coil jacketed
- Metering device: Cap tube
- Auger drive: output speed 11 RPM
- Water valve: Float in reservoir
- Drain pump: Magnetic drive, controlled by pressure switch
- Bin control: Ultrasonic

Electrical Components:

- Compressor - 2.8 - 3.1 amps
- Fan motor
- Auger motor, amp draw .4 - .5 amp
- Drain pump motor
- Drain pump switch
- Controller
- Transformer
- Water sensor
- Ice level sensor
- Membrane switch assembly

Control Timers

- Power interruption, time to restart after power restored: 2 minutes
- Auger motor overload, time to restart: 4 minutes
- Auger motor overload, restart window: 60 seconds
- Auger motor low current, time to restart: 20 minutes
- Auger motor low current, restart window: 60 seconds
- Clean cycle time: 40 minutes total.

Note: During the auger motor restart window times, there is no visible indication that the unit is in a restart mode.

Light Blink Information

- All blink once and repeat every 2 seconds: Auger motor overload
- All blink twice and repeat every 2 seconds: Auger motor low current
- All blink once and repeat every 10 seconds, controller failure.
- Water light blinks red: water supply failure

Controller Reset:

- Cycle power off and on

Diagnostic Codes: No diagnostic codes are kept

Time to Clean indicator light standard interval to switch light on is 6 months, it can be changed to once per year or disabled.

To Adjust:

1. From Off, press and hold the On/Off and Clean Reset Buttons for 5 seconds.
2. Press and Hold the Clean Reset Button for 5 seconds, then press On/Off. Then press On/off again to cycle thru the settings:

	Ice Making	Water	Time to Clean
6 months	On	Off	Off
1 year	Off	On	Off
Disabled	Off	Off	On

Light will automatically go out after a few seconds of inactivity. Press Time To Clean to lock in the new setting.

Quick reset of time to clean light: Press and hold the Clean Reset button for 3 seconds.

GEMU090

Service

Electrical Sequence

Upon power being supplied, all the lights will blink once and the control system will immediately check for water in the reservoir. If there is water no further action will occur until the On/Off button is pushed.

Pushing the On/Off button starts the machine. The Ice Making light will switch on. The auger motor, compressor and fan will begin to operate. Those three components will continue to operate until the Ice Level Control detects that ice has built up to the pre-set level. At that point the control system will begin a shut down process by shutting off the compressor and fan motor.

After sixty seconds the auger motor will shut off. The purpose of this is to remove any ice from the evaporator so the auger motor can restart with minimal load.

The machine will restart after the ice level has fallen one inch or more.

Other Control Functions:

To Shut Off: Push and release the On/Off button. If the machine was off because the bin was full, the unit will be switched to Off immediately. If the unit was making ice, the compressor and fan motor will shut off immediately, and the auger motor shut off in sixty seconds. To shut the unit off immediately while making ice, push and HOLD the On/Off button until it shuts off.

To Clean: See Maintenance section for step by step process. Pushing the Clean button while the Ice Making light is On does not start the clean cycle, it is only active from Off. Pushing the Clean button from Unit Off starts the clean cycle:

- Time to Clean light flashes
- Auger motor operates for twenty minutes
- Auger motor and compressor operate for twenty additional minutes
- Unit shuts off, Time to Clean reminder light switches Off.

Safety Shut Downs:

Lack of water. It is critical that the unit not operate without a full charge of water. The water sensor in the reservoir is used to check continuity through

the water it is in contact with. If there is no water present, there will be no electrical continuity and the control system will stop the machine and cause the Check Water light to blink Red, alerting the user of a lack of water. When water has returned to the reservoir, the unit will automatically restart.

Power interruptions: If the power to the machine failed during normal operation, the machine will automatically restart after a two minute delay. If the unit had shut down because of a safety, then the unit remains in the shut down state.

Auger motor overload: If the auger motor current exceeds the preset limit for a certain time, the controller will shut the compressor and auger motor off. The controller will keep the compressor and auger motor off for four minutes, then restart them. The controller records each overload as a strike. It will erase the strike(s) if the current draw in the sixty seconds following the restart is below the preset limit. If within the sixty seconds after the restart the current again exceeds the limit, the controller again shuts the machine down and a second strike is recorded and four minutes later a second restart occurs. If the current is again excessive the third time, the unit will stop restarting and the lights will flash on and off every two seconds.

Auger motor low current: If the controller senses the auger motor is not drawing any or minimal current, it will shut the compressor and auger motor down for twenty minutes before attempting a restart. The twenty minutes are intended as time for the auger motor to cool off if it has shut down on its internal overload. The controller records that as a strike. If in the next sixty seconds the auger motor begins to draw current the strike is erased and normal operation resumes. If the current is still low, a second strike is recorded and the unit will wait another twenty minutes before attempting a third restart. If the third restart is normal, the strikes are erased and normal operation is continued. If the unit fails again, the unit will stop restarting and the lights will flash twice on and off every two seconds.

Controller Failure: If all lights are flashing once every 10 seconds the controller has identified an internal failure and must be replaced.

GEMU090
Service
Service Diagnosis

Problem	Likely Cause	Probable Solution	
No ice	No power	Plug unit into power supply	
	Unit switched off	Push and release on/off button	
	No water, water diagnostic light is on		Restore water supply, check sensor. If RO water is too pure, unit cannot operate.
			Check float valve for restriction
			Check float valve shut off lever position
	Compressor on, fan on, auger motor not operating		Check auger motor for voltage, if none, replace controller. If there is voltage, check auger motor windings, if open, replace auger motor.
	Compressor on, fan on, auger motor cutting off on over amp safety		Check evaporator for ice. Thaw out and retry. Check top bearing and condition of auger. Replace if worn. Operate unit for a short time with auger out of machine, water shut off and water sensor bypassed. If auger motor still overloads, replace gear reducer.
	Compressor on, auger on, fan blade not turning		Check fan blade for ease of rotation, remove any blockage and retry. Check fan motor, replace if not turning freely or motor windings open.
	Auger motor on, fan on, compressor not drawing power		Check compressor start relay, check compressor windings.
	Auger motor on, fan on, compressor cutting off on overload		Check compressor. See component diagnostics.
	Compressor on, fan on, auger motor on, ice sweep not turning		Check ice sweep. If tight to auger, auger is not turning. Gears stripped, replace gear reducer.
	Unit off on auger motor open safety		Check connections to auger motor, if voltage to motor and it does not operate, replace motor.
	Unit plugged in but no power		If pump model check for water back up or open safety switch.
			Check transformer, replace if not supplying 12 volts AC to controller.
Check switch membrane. See component diagnostics.			
If transformer and membrane are good, replace controller.			

GEMU090
Service
Service Diagnosis

Problem	Likely Cause	Probable Solution
No ice, continued	Ice level sensor failure	With power on and Ice Making light on, check connector, if secure jump the two middle pins at J2 (bin stat) on the controller together. Unit should start. If it does, replace the sensor, if not, replace the controller.
	Auger motor on but compressor and fan motor are off.	Restart unit. Check for power to compressor and/or fan motor. If none, replace controller. Ice Making light blinking. Condition is temporary, unit has been switched off.
	Ice making light on, nothing operating.	May be in a restart window. See page 7.
Not keeping up, makes ice but less than normal	Dirty condenser	Vacuum condenser fins
	Air flow blocked	Check for vent blockage
	Gravity drain restricted	Check drain, clear of restriction. Ensure it has a proper air vent.
	Pump drain slow	Check for proper pump switch operation and drainage
	Scale on evaporator and auger	Clean with scale remover. See Maintenance section.
	Torn door gasket, door does not close tightly	Check gasket and door fit.
Makes ice but also an unusual noise	Panels vibrating	Check panels, adjust fit, tighten screws
	Fan blade rubbing	Check fan blade for foreign object. Remove same. Check alignment.
	Scale on evaporator and auger	Clean with scale remover. See Maintenance section.
	Drain pump cuts in and out.	Check valve failure, replace.
	Tubes rubbing	Check for tube contact to panel or another tube.
	Unit in very cold conditions	Do not operate unit below limits
Water Leak	Drain tube off or cracked	Check/repair drain tube
	Water inlet connection loose	Check/tighten connection
Water flows continuously	Float valve not shutting off	Check float, if stuck free it. If leaking by when full, replace the valve.

GEMU090

Service

Component Diagnostics

Membrane Switch

Unplug and check connector pins (left side is pin 1), read about 10 ohms when activating the button, and OL when not pressing the button: Pin 2-3 On/Off Switch; 4-3 Clean Reset Switch



Compressor

Check temperature of compressor, if very hot, add access valves to refrigeration system and check system pressures. If very low, add very small amount of R-134a. If pressure does not improve, capillary tube may be restricted. If pressures improve find and correct refrigerant leak.

If compressor temperature is normal and compressor is drawing high amps, check start relay.

If relay is good and compressor is not overheating but drawing high amps, replace compressor.

Pump Switch - Pump model only

The pump switch activates the pump based on pressure to it from water inside the drain hose to the pump inlet. It is normally open. When pressure increases the switch closes, turning on the pump motor until the pressure falls.

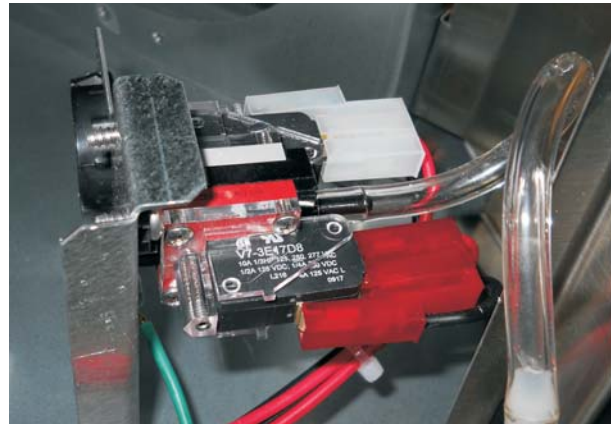

The safety switch (the red one) is normally closed and operates at a higher activation pressure than the pump switch. It stops operation of the machine if it opens.

Ice Level Sensor

To operate, the unit must have:

- Power to the controller
- Water sensed
- Call for ice

With power on and Ice Making light on, check sensor connector, if secure and the unit not operating, remove connector and jump the two middle pins at J9 on the controller together. Unit should start. If it does, replace the sensor, if not, replace the controller.

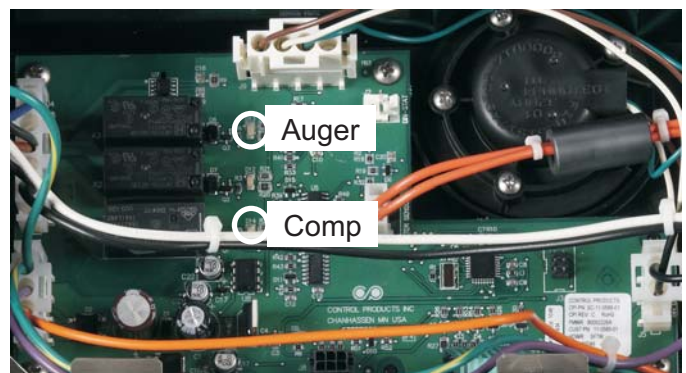

GEMU090

Service

Ice Capacity

The rate of ice making is relatively fixed, it depends upon the heat load and the ambient temperature the machine is operating in. As either increase the amount of ice made will decrease.

The machine will work to keep the ice bin full. A full bin of ice is when the ice level is even with the top of the front of the bin. When the ice level drops an inch or more the machine will restart.

A capacity check will provide some idea of how much ice is being made.

1. Operate the machine for 10 minutes until it is stabilized.
2. Catch the ice as it is made for 15 minutes.
3. Weigh the ice and any melted water.
4. Multiply the weight from step 3 by 96 to get 24 hour capacity.
5. Compare to the chart below:

90°F. Air, 70°F water	59 lb / 24 hours
70°F. Air, 50°F. water	87 lb /24 hours

Note: Mineral scale build up inside the evaporator will reduce the ice making rate, as will any lint or dirt on the air cooled condenser or fan blade. All ice making capacities listed by Ice-O-Matic are for clean, new machines.

The ice storage bin is not refrigerated; it is an insulated ice chest, so there is meltage. A restricted drain or poorly operating drain pump will allow water to puddle in the bin, increasing the ice melt rate. A stopped up drain will cause the bin to fill with water.

Refrigerant charge.

The charge is very small. Any leak will immediately result in a loss of ice making capacity and continued leaking will result in no ice being made. The system is sealed, access must be by clamp on valves, which must be removed after the repair is completed.

Noise

Normal ice making produces very little noise; there will be sound from the compressor, fan and auger drive motor. If there is a drain pump it will cycle occasionally too. If the machine is making an unusual noise that might be a sign that it needs to be cleaned of mineral build up.

GEMU090

Service

Removal and Replacement

Component Access

The machine is designed to be cleaned while built in. See the Maintenance section for more information.

Most components require the machine to be removed from a built-in situation:

- Fan motor – side service panel
- Controller – top panel
- Auger motor – top panel, back panel
- Ice sensor – top panel
- Drain pump – side service panel
- Top bearing – top panel
- Gear reducer – top panel, back panel
- Ice sweep – top panel
- Water seal – top panel, back panel, bin back panel
- Water reservoir or float - top panel

Evaporator / Auger / Water Seal / Gear Reducer Service

The auger, top bearing, water seal and gear reducer can be replaced without disturbing the refrigeration charge. If the evaporator must be replaced, then the refrigeration system must be accessed so the charge can be recovered.

Evaporator construction

The evaporator is made up of a stainless steel tube, wrapped with a coil of copper and then heavily insulated. There is no refrigerant path to the water inside of the evaporator. The inside of the tube is polished and rifled with 12 vertical grooves that help guide the ice straight up the tube.

It is normal for mineral scale from the water to form on the inside of the evaporator tube. That scale must be removed by use of ice machine scale remover using the process described in Maintenance. Heavy scale build up will require the process to be repeated. The inside of the evaporator tube may be sanded vertically to remove tough build up. Do NOT hone or clean with a wire brush on a drill, as horizontal marks on the inside of the evaporator will restrict the flow of ice.

A damaged evaporator must be replaced.

The auger can also have scale build up which must be removed. It works best when it is clean and shiny. Note that a wet auger will appear clean but when dry the scale will be visible. Dry off the auger (use your heat gun) to determine if it's clean. If the machine has been operated with worn bearings, the auger may have rubbed the evaporator wall. If the spiral edges or flights of the auger are damaged, the auger must be replaced.

The ice breaker at the top of the evaporator contains the pressed-in bearing. This bearing must not be greased. If worn, the breaker with bearing can be replaced.

The gear reducer is a sealed unit. The only service part available for it is the drive motor and drive motor capacitor.

Lubricants and Sealants

Food grade lubricant is useful in repair of this model. Ice-O-Matic part number 6051036-01.

Food grade sealant is needed in repair of this model. Ice-O-Matic part number 6051011-01.

GEMU090

Service

GEM090 Gearbox Access & Removal

1. Shut off water supply
2. Remove drain plug inside bin compartment
3. Disconnect power supply or unplug unit

	<p>⚠ WARNING</p> <p>Hazard of Electrical Shock.</p> <p>Disconnect Electrical Power Before Servicing.</p>
---	--

4. Uninstall unit and pull out as needed for top and back access.
5. Remove top panel
6. Remove back panel
7. Remove ice chute/bin wall by unscrewing 2 thumb screws and lifting it out

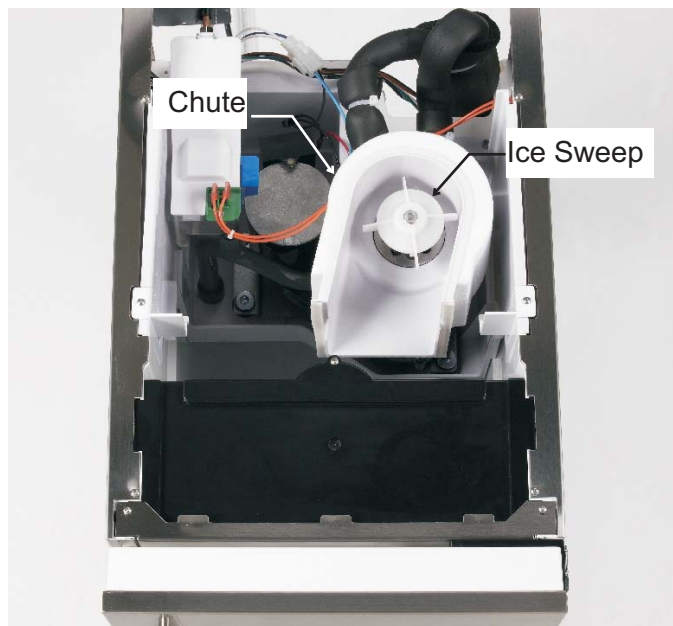

8. Remove 2 orange wires from water level sensor (on top of float tank)
9. Rotate ice sweep counter-clockwise and remove ice sweep

10. Lift and remove ice chute

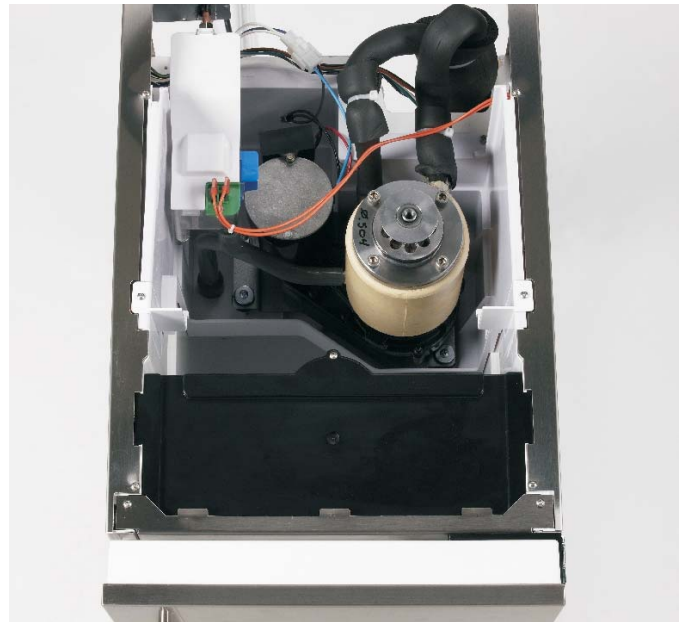

11. Remove 4 screws securing float reservoir & set aside
12. Remove gray water tube from evaporator inlet
13. Disconnect power connection to auger motor
14. Remove 4 bolts securing breaker head to freezer by using 1/4" allen wrench (socket type - best method)

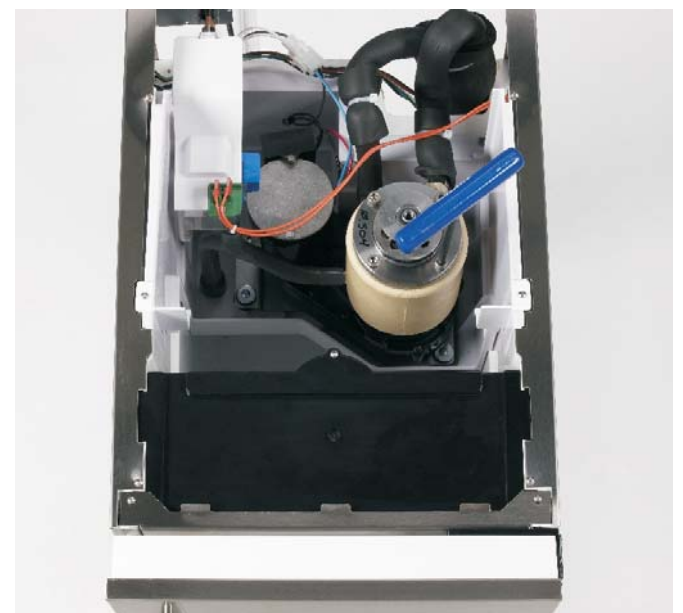

GEMU090

Service

15. Remove breaker & set aside
16. Pull auger from freezer by lifting straight up (be careful as auger has sharp edges!)

Note: If auger does not lift freely, see Auger Removal Procedure.

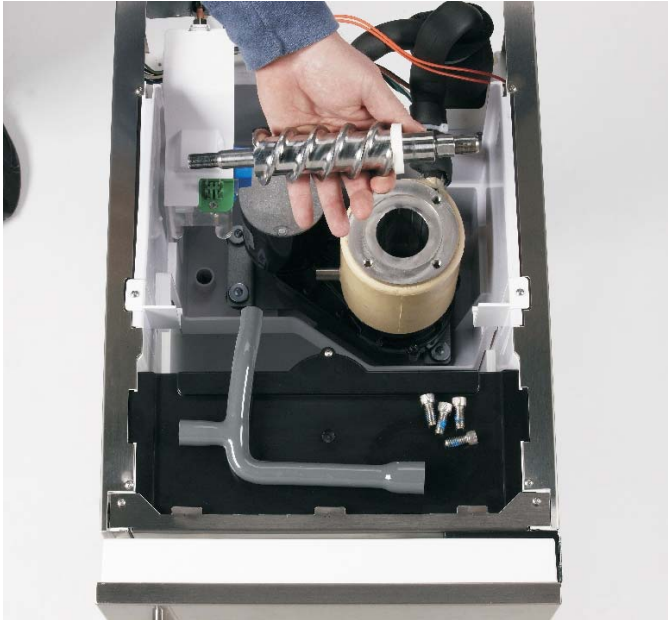

17. Inspect auger flights for signs of wear
18. Inspect evaporator barrel for signs of radial scoring
19. Remove 4 screws securing gearbox bracket to compartment base

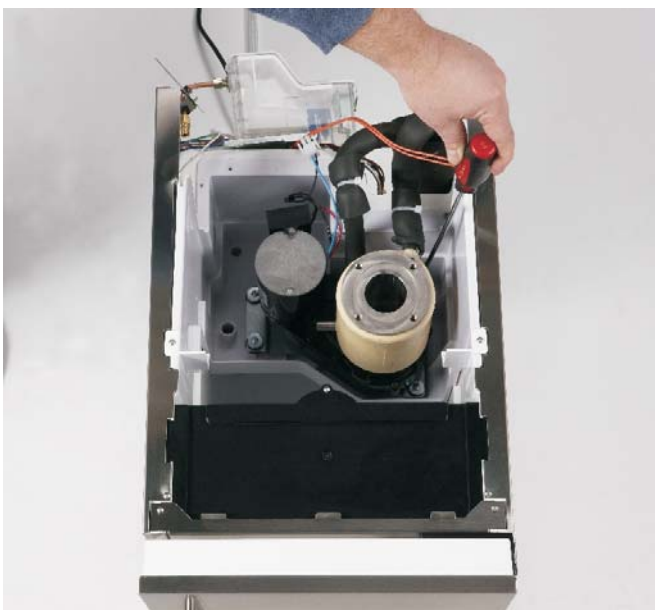

20. Carefully lift and rest gearbox & bracket against back of compartment lip

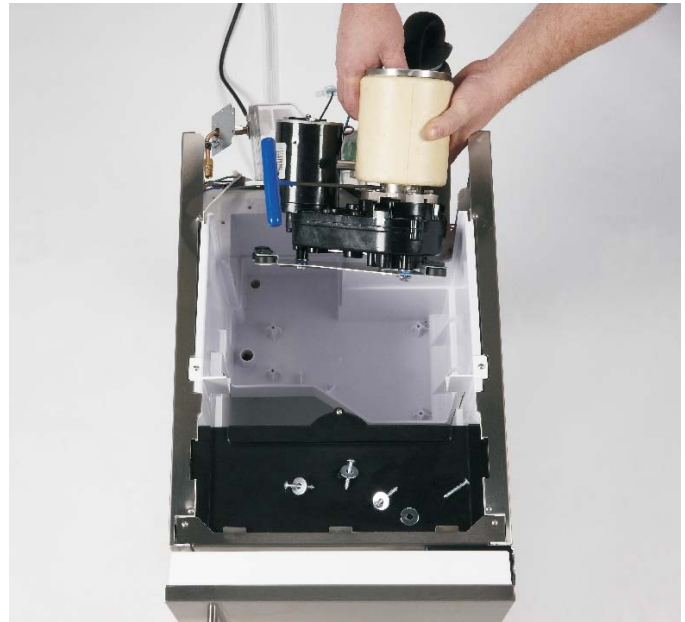

21. Remove four 5/32" allen head screws holding adapter to evaporator



22. Remove evaporator from gearbox

** tools needed-1/4" & 5/32" allen wrench (T handle or socket type suggested), Phillips screwdriver - 12 inch or longer recommended.

Replace gear reducer and install a new water seal.

GEMU090

Service

Water Seal Replacement

- 1 Go through the prior steps to remove the gear reducer.
- 2 Remove rotating half of water seal from bottom of auger.

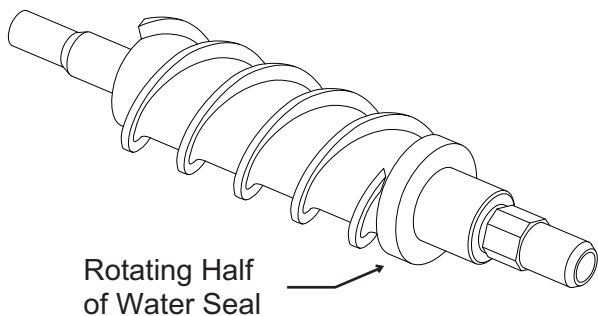

- 3 Clean auger of any sealant at water seal mounting position.

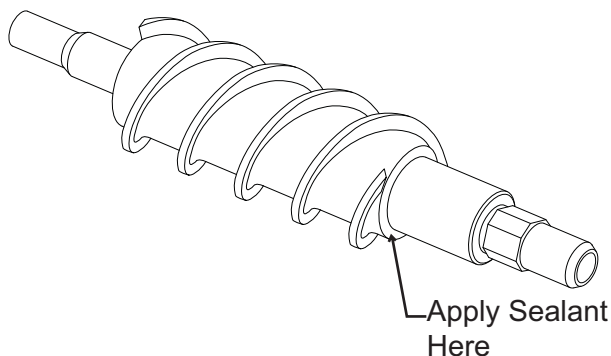

- 4 Add a small bead of food grade silicone sealant to the shoulder of the auger where the water seal will go.

Note: Do NOT touch the mating surfaces of the water seal with fingers or sealant.

- 5 Lubricate / moisten (lightly - use food grade lube) only the rubber part of the new water seal and slide it onto the auger, rubber side against the auger shoulder. Force it onto the sealant as far as it will go.
- 6 Remove the stationary half of the old water seal from the bottom of the evaporator.

- 7 Lubricate or moisten the outer edge of the new seal and push it into the bottom of the evaporator tube until **flush with the bottom of the tube**. Be sure it is in as straight as possible.

Note: Do NOT touch the inner ring of the water seal with fingers or sealant. Wipe off with rubbing alcohol if they were touched.

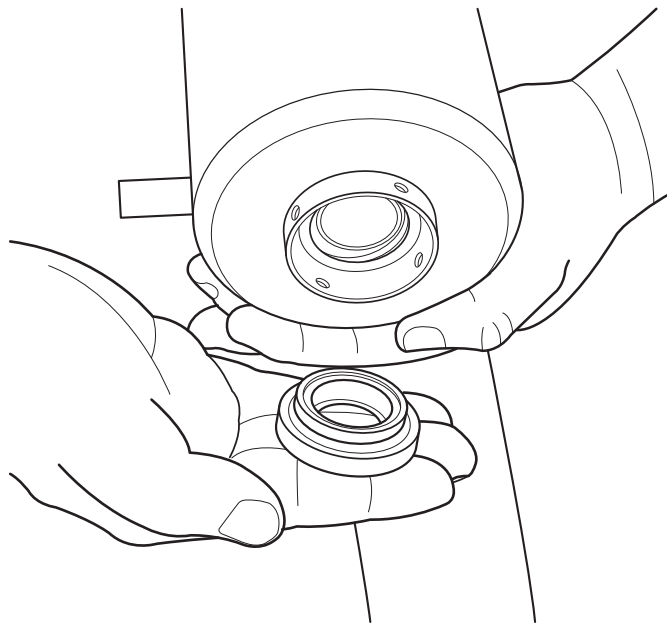

- 8 Position the gear reducer under the evaporator.
- 9 Push the gear reducer and adapter flange up into the bottom of the evaporator until the mounting holes line up. This forces the stationary half of the water seal to the correct location.
- 10 Screw in the four allen head screws into the side of the bottom of evaporator tube.
- 11 Remount the gear reducer and evaporator assembly into the ice machine. Secure the mounting pan with the original screws.
- 12 Carefully lower the auger with the other half of the water seal attached into the evaporator tube. Rotate auger until it slips into place.

GEMU090

Service

- Slide breaker onto auger shaft. Secure with the original four allen head bolts.
- Reverse the balance of the steps to complete putting the machine back together.

Gear Reducer Replacement

- The gear reducer contains no internal serviceable parts. Replace as a unit.
- Follow all steps to remove gear reducer from evaporator.
- Remove bolts holding gear reducer to mounting plate.
- Separate gear reducer from mounting plate and attach a new gear reducer.

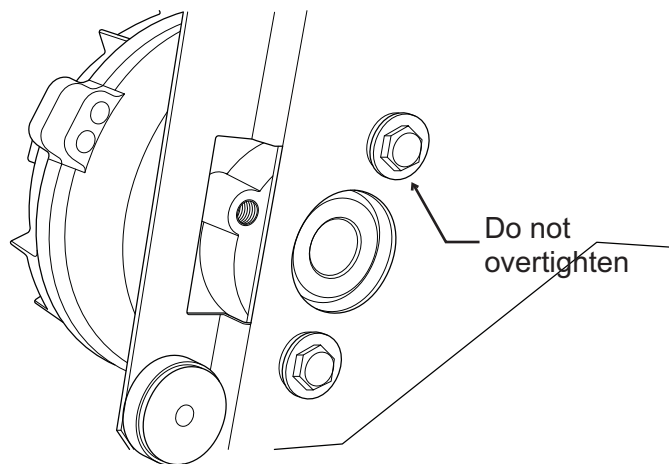

Note: Do NOT overtighten bolts securing gear reducer to mounting plate. Tighten only until the washer contacts the blue grommet.

Ice Breaker Replacement

- Disconnect power supply or unplug unit
- Uninstall unit and pull out as needed for top access.
- Remove top panel
- Rotate ice sweep counter-clockwise and remove ice sweep
- Remove ice chute
-

Remove 4 allen head screws holding breaker to evaporator.

- Lift breaker off and replace with a new part.

Note: Be sure auger shaft is smooth and undamaged. A dark finish at the bearing area is normal. Replace auger if damaged.

Auger Replacement

Auger replacement requires a new water seal. Follow all steps to replace the water seal except substitute a new auger.

Auger Removal Procedure

If the auger does not lift freely, it may be stuck in the gear reducer. To release it:

- Remove ice sweep.
- Remove 4 allen head bolts holding breaker to evaporator.
- Place 4 hex nuts (5/8 size) as spacers between the breaker and the top of the evaporator.

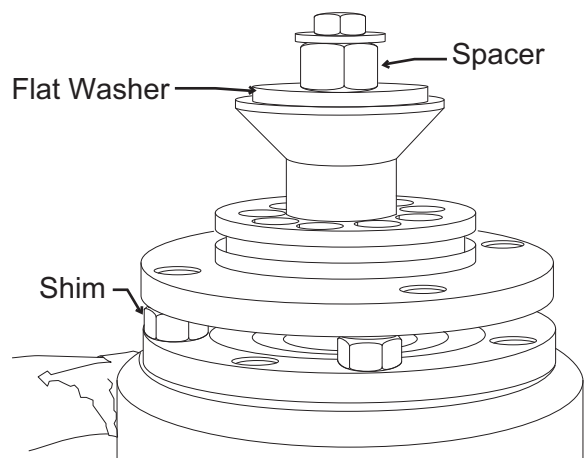

- Place a large flat washer or suitable hex nut (as a spacer) over the top of the breaker.
- Thread a 5/16 - 18 x 1 inch bolt into the top of the auger thru the washer and/or hex nut and screw the bolt into the auger. As it tightens against the nut it should lift and loosen the auger. Once the auger has moved it should lift out easily.

GEMU090

Service

Evaporator Replacement

- 1 Go through all steps to remove the gear reducer.
- 2 Add temporary refrigeration system access valves to the discharge and suction sides of the refrigeration system .
- 3 Recover the refrigerant.
- 4 Un-sweat the suction line and cap tube connections from the evaporator.
- 5 Remove original dryer.
- 6 Attach permanent access valves to system.
- 7 Attach dry nitrogen to system and purge at about 1 lb pressure while brazing all connections, including access valves, dryer and evaporator.
- 8 Remove nitrogen source, evacuate system to 300 microns or less.
- 9 Weigh in the nameplate charge.
- 3 Disconnect electrical power.
- 4 Remove control box cover
- 5 Unplug all wires.
- 6 Remove screws holding controller to box.
- 7 Remove controller.
- 8 Before touching replacement controller, touch a metal surface of the cabinet to discharge any static electricity.
- 9 Place new controller in control box, connect all wires previously removed.
- 10 Reverse remaining steps to reassemble.

Water Reservoir

- 1 Pull unit out to get access to top and back panel.
- 2 Shut water supply off.
- 3 Pull drain plug and drain all water. Return plug to its original position.
- 4 Loosen nut at water valve inlet and separate inlet tube from reservoir valve.
- 5 Pull outlet hose off reservoir tank.
- 6 Remove screws holding reservoir to unit and lift off.
- 7 Reverse steps to reassemble.

Controller

- 1 Pull out to get access to top panel.
- 2 Remove top panel.

Ice level sensor

- 1 Pull out to get access to top panel.
- 2 Remove top panel.
- 3 Disconnect electrical power.
- 4 Remove control box cover
- 5 Unplug wire at J9.

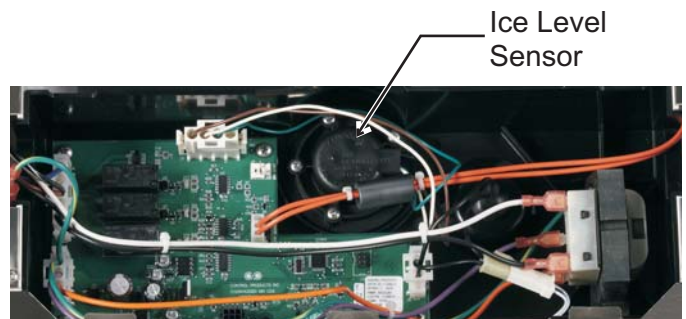

- 6 Remove 5 screws and lift sensor from control box.
- 7 Replace with new part.
- 8 Reverse remaining steps to reassemble.

GEMU090

Service

Drain Pump (if equipped)

- 1 Shut off water supply
- 2 Remove all ice and/or any standing water.
- 3 Disconnect power or unplug unit
- 4 Uninstall and pull unit out to get access to left side service panel.



- 5 Remove five screws and the service panel.
- 6 Disconnect electrical plug to pump motor
- 7 Disconnect drain hose from pump inlet
- 8 Disconnect discharge hose from pump
- 9 Remove two 3/8 inch nuts holding pump to base, lift pump up and out.
- 10 Reverse steps to reassemble.

Fan Blade or Motor

- 1 If equipped with drain pump follow all steps to remove pump.
- 2 Unplug fan motor connection.
- 3 Remove four screws holding fan motor brackets to shroud.
- 4 Pull fan blade and motor from unit.

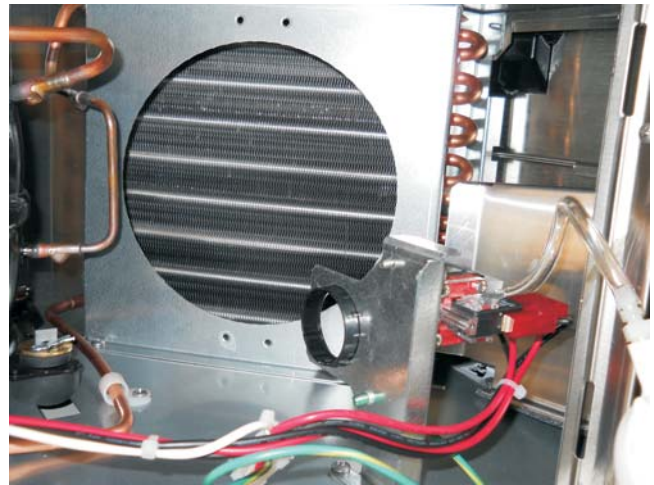

- 5 If not equipped with a drain pump:
- 6 Shut off water supply
- 7 Remove all ice and/or any standing water.
- 8 Disconnect power or unplug unit
- 9 Uninstall and pull unit out to get access to left side service panel.
- 10 Remove five screws and the service panel.
- 11 Unplug fan motor connection.
- 12 Remove four screws holding fan motor brackets to shroud.
- 13 Pull fan blade and motor from unit.
- 11 Service blade or motor and reverse to reassemble.

GEMU090

Service

Compressor replacement.

Note: If built in the unit will need to be pulled out.

Note: Placing it over the leg leveler and next to the strut works the best.

- 1 Shut off water supply
- 2 Disconnect power supply or unplug unit
- 3 Uninstall unit and pull out as needed for side and back access.
- 4 Remove all panels and door:
 - Back panel including drain and power supply panels.
 - Side service panel
 - Kickplate
 - Top panel
- 5 Go through all steps to remove drain pump and/or fan motor.
- 6 Remove drain hose from unit.
- 7 Obtain or make an 11" prop from 3/4" PVC or similar.
- 8 Remove 2 screws (at back) holding base to side panels
- 9 Remove screws holding strut to base
- 10 Remove screw holding left side panel to base
- 11 Loosen BUT DO NOT REMOVE two screws at front holding side panels to base
- 12 Lift back of unit up and support with the 11" prop.
- 13 Add temporary refrigeration system access valves to the discharge and suction sides of the refrigeration system.
- 14 Recover the refrigerant.
- 15 Remove the four hair pins securing compressor to chassis.
- 16 Disconnect wires, overload and relay from compressor.
- 17 Push back suction line insulation.
- 18 Unsweat the discharge and suction connections at the compressor.
- 19 Remove the compressor from the unit.
- 20 Remove dryer from unit.
- 21 Attach permanent schrader access valves to unit.
- 22 Attach dry nitrogen supply to access valves, purge at about 1 lb pressure during brazing.
- 23 Install new dryer.
- 24 Install new compressor. Install at least 3 of the hair pins to secure the compressor. The fourth is optional.
- 25 Make all braze connections needed to seal system.
- 26 Remove nitrogen supply. Evacuate system to at least 300 microns.
- 27 Weigh in nameplate charge.
- 28 Reconnect all wires, components and panels removed to access compressor.
- 29 Reinstall unit. Operate unit and test.

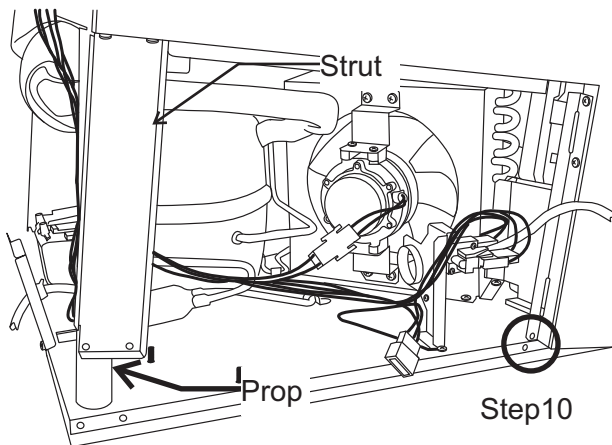
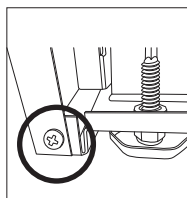

GEMU090

Service

Bin and Cabinet

The bin and cabinet can be separated from the base. Either the ice making evaporator system must be lifted out and securely suspended or the refrigeration system opened and the connections to the evaporator unbrazed.

- 1 Remove the unit from its installed position.
- 2 Disconnect water supply.
- 3 Disconnect / unplug unit from power supply.
- 4 Drain evaporator.
- 5 Empty bin of ice and water.
- 6 Disconnect drain hose from bottom of bin.
- 1 Remove top, back and side service panels.
- 7 Remove door.
- 8 Remove kickplate.
- 9 Remove front service panel
- 10 Remove screw holding service panel bracket.
- 11 Remove two screws holding baffle at right side of condenser.
- 12 Unplug wires from compressor and fan motor. Be sure wires from control box to base are free and disconnected.
- 13 Remove four screws holding each corner of the chassis to the base.
- 14 Remove two screws holding left rear strut to base.
- 15 Remove one screw holding left side panel to base.
- 16 Either go thru the process to remove gear reducer and evaporator from unit **or** recover refrigerant and disconnect at evaporator.

Note: If leaving evaporator & gear reducer in unit, have a helper support them while the cabinet is removed.

- 17 Lift bin and cabinet off chassis.

Auger Motor or Motor Capacitor

- 1 Remove the unit from its installed position.
- 2 Disconnect water supply.
- 3 Disconnect / unplug unit from power supply.
- 4 Empty bin of ice and water.
- 5 Remove top panel.
- 6 Remove both bolts holding motor to gear reducer.
- 7 Lift motor winding and capacitor up and out of machine.
- 8 Cut wires and separate winding from capacitor. Change either and reconnect motor to capacitor.

Note: Be SURE wires are connected per the label on the motor: Black to Black to Capacitor and Red to Capacitor. If connected incorrectly, motor will turn the wrong way. Output shaft or auger MUST turn CCW (counterclockwise) looking from above or the unit will be damaged during ice making.

- 9 Pull rotor from gear reducer (if changing motor)
- 10 Insert new rotor (if changing motor).
- 11 Reinstall winding and capacitor assembly. Secure with the original screws.
- 12 Return all panels to their original positions.
- 13 Reconnect water and power.
- 14 Reinstall unit.

Schematic Diagram

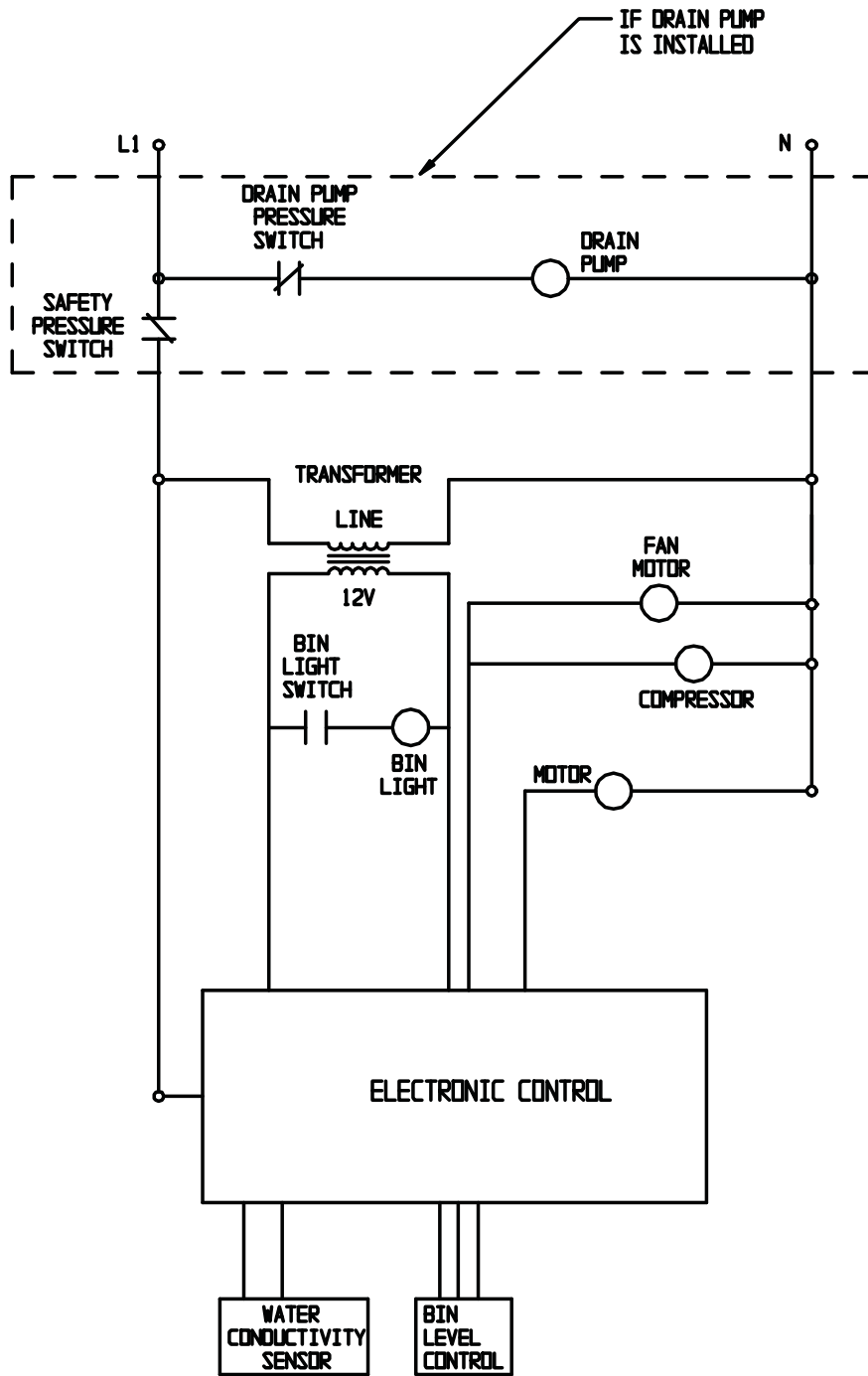

SWITCHES ON THIS UNIT
SHOWN IN FREEZE CYCLE
WITH DRAIN PUMP IN OPERATION
AND BIN DOOR CLOSED