

Ice-O-Matic[®]

Service Parts Manual GEMD520 & GEMD540 GEMD525



GEMD520 & GEMD540 SERVICE PARTS

This parts list contains the service parts and wiring diagrams for this model. Check the model number of the machine requiring the parts to be sure that this is the correct parts list.

TABLE OF CONTENTS

Cabinet Assembly	Page 2
Air Cooled Refrigeration	Page 4
Water Cooled Refrigeration	Page 5
Ice Dispensing	Page 6
Evaporator	Page 7
Gearmotor Assembly	Page 8
Control Box	Page 9
Water System	Page 10

GEMD520 & GEMD540 SERVICE PARTS

Cabinet

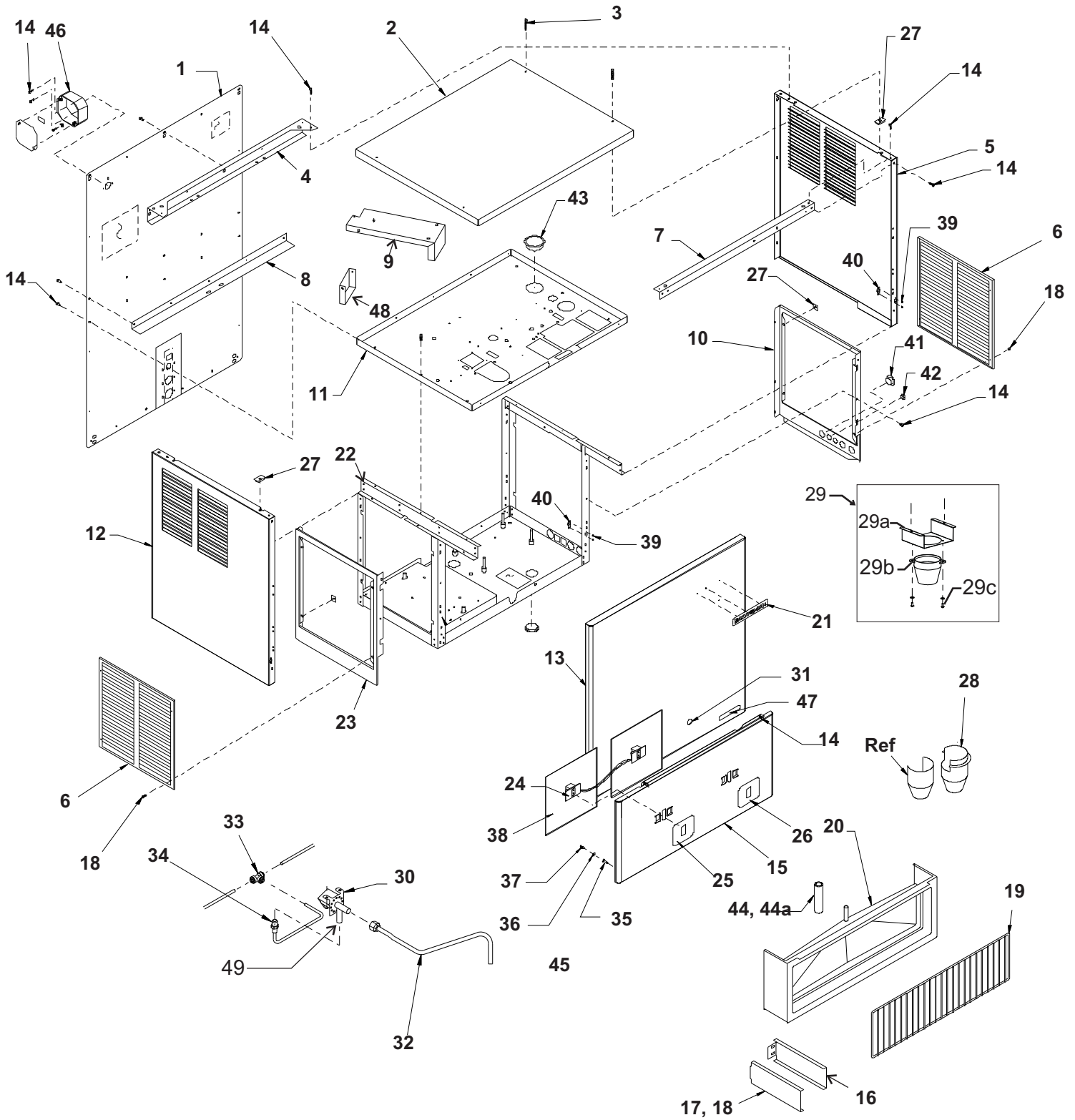

GEMD520 & GEMD540 SERVICE PARTS

Cabinet

GEMD520

GEMD540

ITEM NUMBER	PART NUMBER	DESCRIPTION	ITEM NUMBER	PART NUMBER	DESCRIPTION
1	1011447-119	Back Panel, stainless	1	1011447-125	Back Panel, stainless
2	1011447-172	Top Panel, stainless	2	1011447-172	Top Panel, stainless
3	1011351-35	Panel screw	3	1011351-35	Panel screw
4	1011447-113	Hanger Brace	4	1011447-113	Hanger Brace
5	1011447-171	Rt. side panel, stainless	5	1011447-177	Rt. side panel, stainless
6	1011447-126	Service panel, stainless	6	1011447-126	Service panel, stainless
7	1011447-114	Front Brace	7	1011447-114	Front Brace
8	1011447-115	Support angle	8	1011447-115	Support angle
9	1011447-116	Gearmotor Support	9	1011447-123	Gearmotor Support
10	1011447-118	Rt. side lower, stainless	10	1011447-118	Rt. side lower, stainless
11	1011447-120	Upper plate assembly	11	1011447-120	Upper plate assembly
12	1011447-170	Lt. side panel, ss	12	1011447-176	Lt. side panel, ss
13	1011447-173	Up front panel, stainless	13	1011447-178	Up front panel, stainless
14	9031046-27	Screw	14	9031046-27	Screw
15	1011447-179	Splash panel with labels	15	1011447-179	Splash panel with labels
16	1011447-155	RH sink support	16	1011447-155	RH sink support
17	1011447-155	LH sink support	17	1011447-155	LH sink support
18	1011339-74	Screw	18	1011339-74	Screw
19	1011447-10	Grill	19	1011447-10	Grill
20	1011447-09	Sink, gray	20	1011447-09	Sink, gray
21	9071974-01	Emblem	21	9071974-01	Emblem
22	1011447-121	Lower frame assy	22	1011447-121	Lower frame assy
23	1011447-117	Lt side lower, stainless	23	1011447-117	Lt side lower, stainless
24	1011447-52	Touch free sensors	24	1011447-52	Touch free sensors
25	1011447-78	Ice label, grey	25	1011447-78	Ice label, grey
26	1011447-79	Water label, grey	26	1011447-79	Water label, grey
27	1011447-37	Speed nut	27	1011447-37	Speed nut
28	1011447-20	Water chute	28	1011447-20	Water chute
29			29		
29a	1011447-191	Bracket	29a	1011447-191	Bracket
29b	1011447-26	Chute	29b	1011447-26	Chute
29c	9031046-27	Screw	29c	9031046-27	Screw
30	1011447-45	Solenoid Assembly (115v)	30	1011447-45	Solenoid Assembly (115v)
	1011447-47	Solenoid (230v)		1011447-47	Solenoid (230v)
31			31		
32	1011447-164	Water line	32	1011447-164	Water line
33	1011447-73	Tee union	33	1011447-73	Tee union
34	1011447-74	Connector	34	1011447-74	Connector
35	1011351-41	Insert	35	1011351-41	Insert
36	1011447-35	Lock washer	36	1011447-35	Lock washer
37	1011351-40	Ball stud	37	1011351-40	Ball stud
38	1011447-99	Insulation pad	38	1011447-99	Insulation pad
39	no number	Rivet	39	no number	Rivet
40	1011447-39	Retainer	40	1011447-39	Retainer
41	1011447-02	Hole plug	41	1011447-02	Hole plug
42	1011447-03	Hole plug	42	1011447-03	Hole plug
43	no number	Bushing	43	no number	Bushing
44	1011447-61	Hose, order 1	44	1011447-61	Hose, order 1
44a	1011447-06	Hose clamp	44a	1011447-06	Hose clamp
45			45		
46	1011447-43	Junction box	46	1011447-43	Junction box
47	1011447-68	Touch-Free label	47	1011447-68	Touch-Free label
48	Part of item 9		48	Part of item 9	
49	1011447-69	Inlet adapter (half union)	49	1011447-69	Inlet adapter (half union)

GEMD520 & GEMD540 SERVICE PARTS

Air Cooled Refrigeration

ITEM NUMBER	PART NUMBER	DESCRIPTION
1	1011447-27	Insulation
2	9151161-01	Thermo Expansion Valve
3	1011447-189	Suction Line for 520
	1011447-190	Suction Line for 540
4	1011382-09	Evaporator
5	1011380-35	Screw
6	1011447-92	Compressor, 115/60
	1011447-94	Overload for 115 v comp
	1011447-93	Compressor, 230/50
	1011447-95	Overload for 230 v comp
7	1011447-31	Hex nut
8	9151163-03	Dryer
9	9181002-02	Mounting Sleeve
10	9181002-09	Mounting Grommet
11	1011447-90	Fan Motor, 115v 60 Hz
	1011447-88	Fan motor, 230v, 50 Hz
12	1011447-19	Fan Bracket
13	1011447-42	Hi Press. Cut Out
14	1011447-91	Fan Blade
15	1011447-124	Fan Shroud
16	1011447-89	Condenser
17	1011339-74	Screw
18		
18a1	1011380-94	Access valve seat
18a2	1011380-95	Core
18a3	1011380-96	Cap

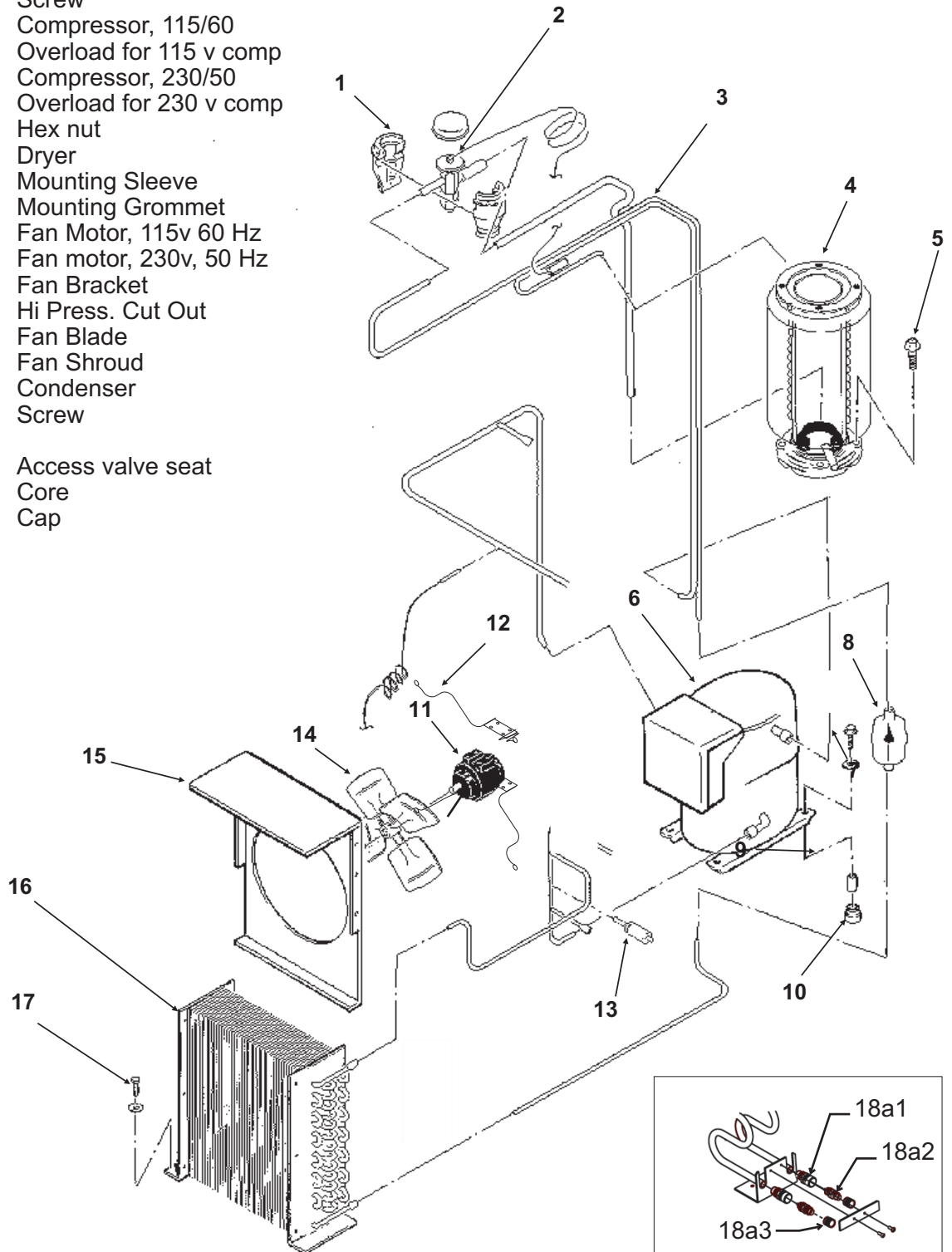

GEMD520 & GEMD540 SERVICE PARTS

Water Cooled Refrigeration

ITEM NUMBER	PART NUMBER	DESCRIPTION
1	1011447-27	Insulation
2	9151161-01	Thermo Exp. Valve
3	1011447-189	Suction Line for 520
	1011447-190	Suction Line for 540
4	1011382-09	Evaporator
5	1011380-35	Screw
6	9151163-01	Drier
7	1011447-31	Hex Nut
8	9181002-02	Mounting Sleeve
9	9181002-09	Mounting Grommet
10	1011447-92	Compressor, 115/60
	1011447-94	Overload for 115 v comp
	1011447-93	Compressor, 230/50
	1011447-95	Overload for 230 v comp
11		
12	1011447-42	High Press. Cut Out
13	1011447-41	Water Reg. Valve
14	1011447-75	Adaptor kit
15	1011447-76	Adaptor kit
16	1011447-29	Screw
17	1011339-62	Lock washer
18	9141141-01	Condenser
16a1	1011380-94	Access valve seat
16a2	1011380-95	Core
16a3	1011380-96	Cap

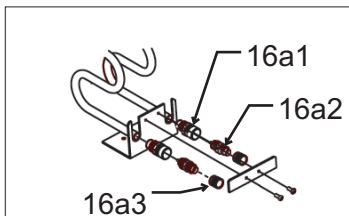
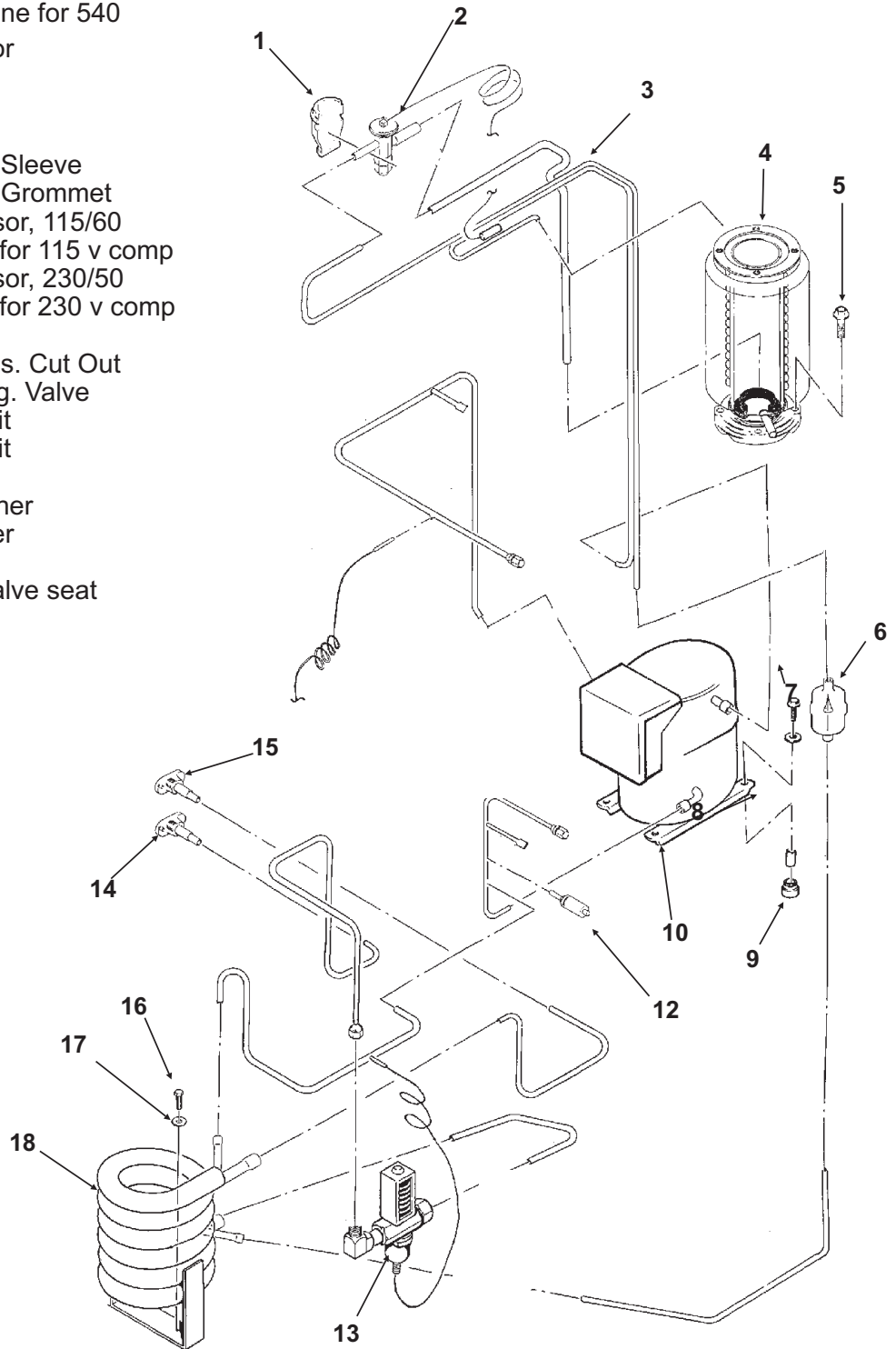

GEMD520 & GEMD540 SERVICE PARTS

Ice Dispensing

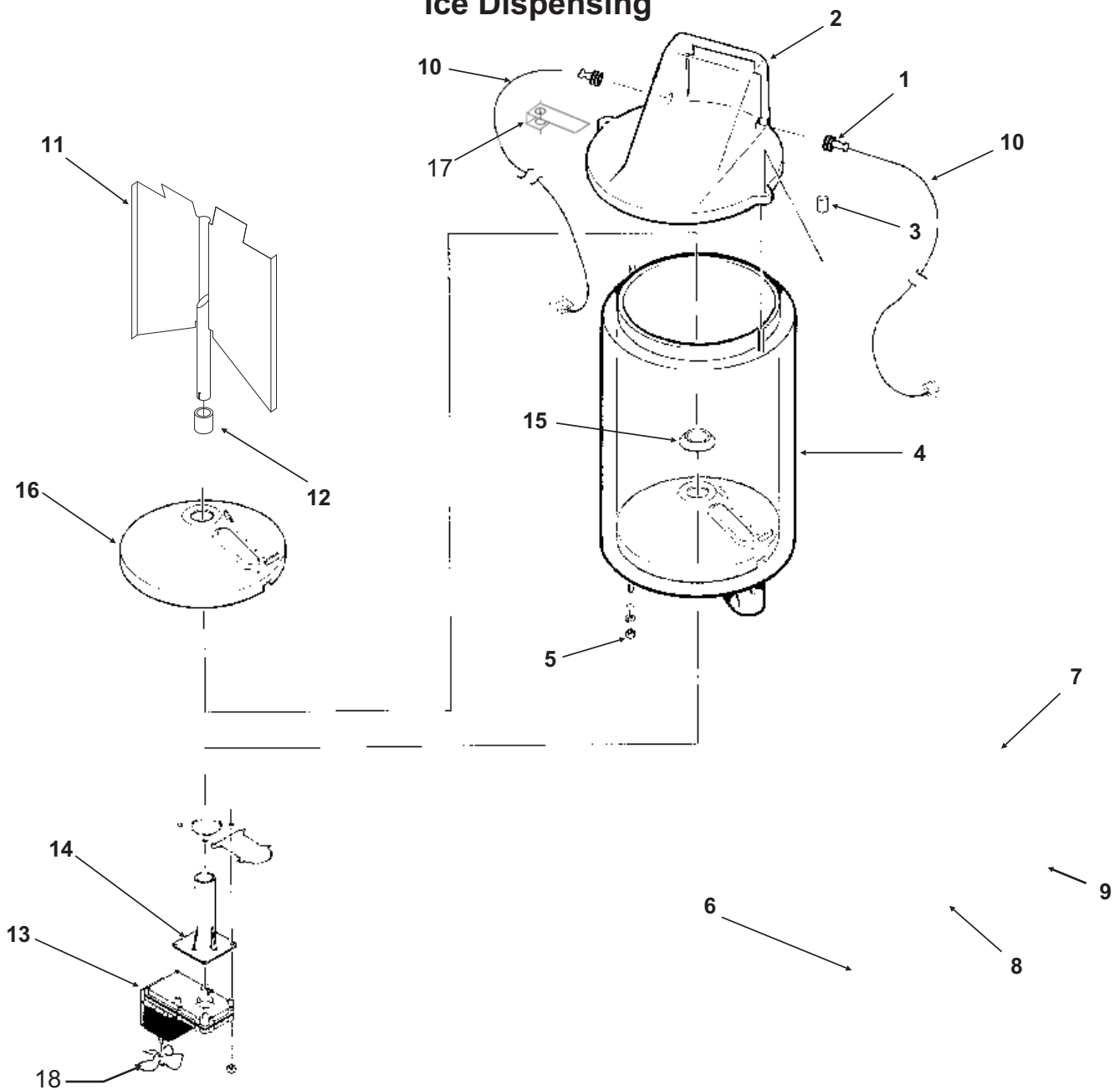

ITEM NUMBER	PART NUMBER	DESCRIPTION
1	1011447-66	Grommet, Bin Control
2	1011447-146	Bin top
3	1011447-185	SS clip
	1011447-28	Wing Nut
4	1011447-147	GEMD520 Storage Bin
	1011447-148	GEMD540 Storage Bin
5	1011447-30	Hex nut
	1011339-62	Lock washer
6	9031046-27	Screw
7	1011447-180	Valve plate
8	1011447-54	Switch (Touch Free off)
9	no number	Wires
10	1011447-168	Ice Level Sensor (set)

ITEM NUMBER	PART NUMBER	DESCRIPTION
11	1011447-167	GEMD520 Bin vane (inc. #12)
	1011447-166	GEMD540 Bin vane (inc. #12)
12	1011447-18	Bearing
13	1011447-55	Bin Drive Motor (115v)
	1011447-56	Bin Drive Motor (230v)
14	1011447-04	Bracket
15	1011447-65	Water Shed
16	1011447-103	Bin Bottom
17	1011447-185	Bin top bracket
18	1011447-44	Fan blade

GEMD520 & GEMD540 SERVICE PARTS

Evaporator

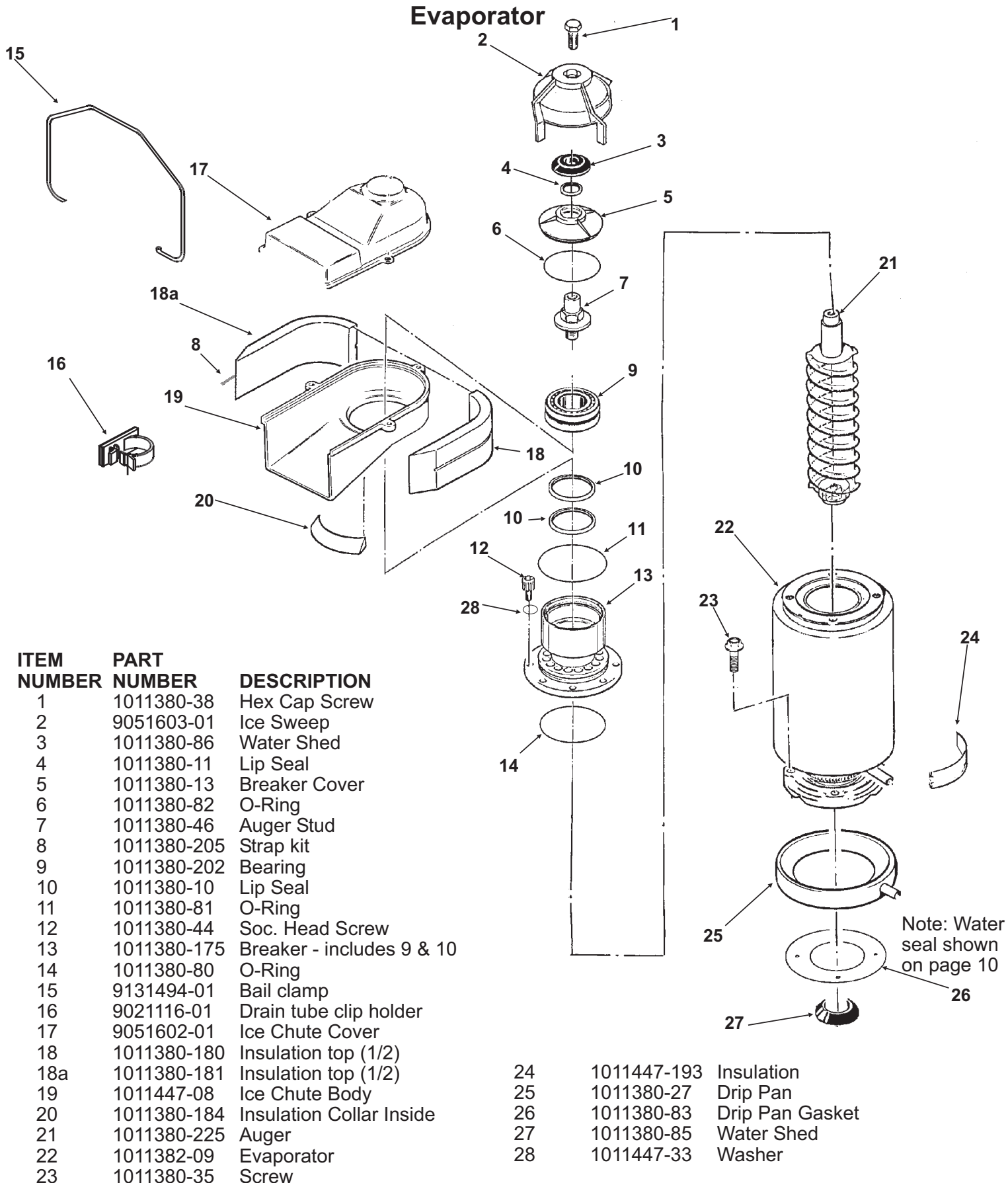

GEMD520 & GEMD540 SERVICE PARTS

Gearmotor Assembly

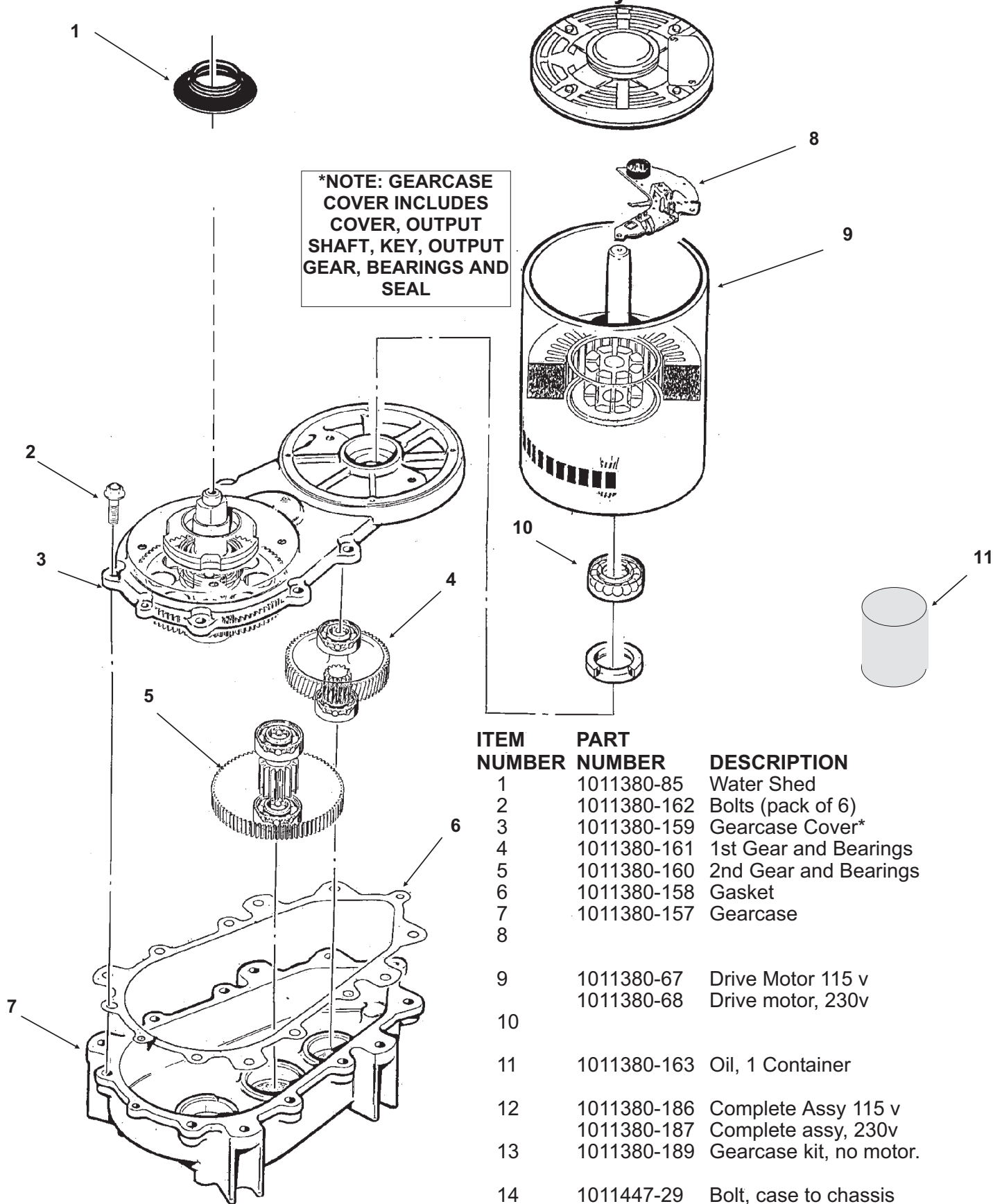

***NOTE: GEARCASE COVER INCLUDES COVER, OUTPUT SHAFT, KEY, OUTPUT GEAR, BEARINGS AND SEAL**

ITEM NUMBER	PART NUMBER	DESCRIPTION
1	1011380-85	Water Shed
2	1011380-162	Bolts (pack of 6)
3	1011380-159	Gearcase Cover*
4	1011380-161	1st Gear and Bearings
5	1011380-160	2nd Gear and Bearings
6	1011380-158	Gasket
7	1011380-157	Gearcase
8		
9	1011380-67	Drive Motor 115 v
	1011380-68	Drive motor, 230v
10		
11	1011380-163	Oil, 1 Container
12	1011380-186	Complete Assy 115 v
	1011380-187	Complete assy, 230v
13	1011380-189	Gearcase kit, no motor.
14	1011447-29	Bolt, case to chassis
15	1011339-63	Washer for item 14

GEMD520 & GEMD540 SERVICE PARTS

Control Box

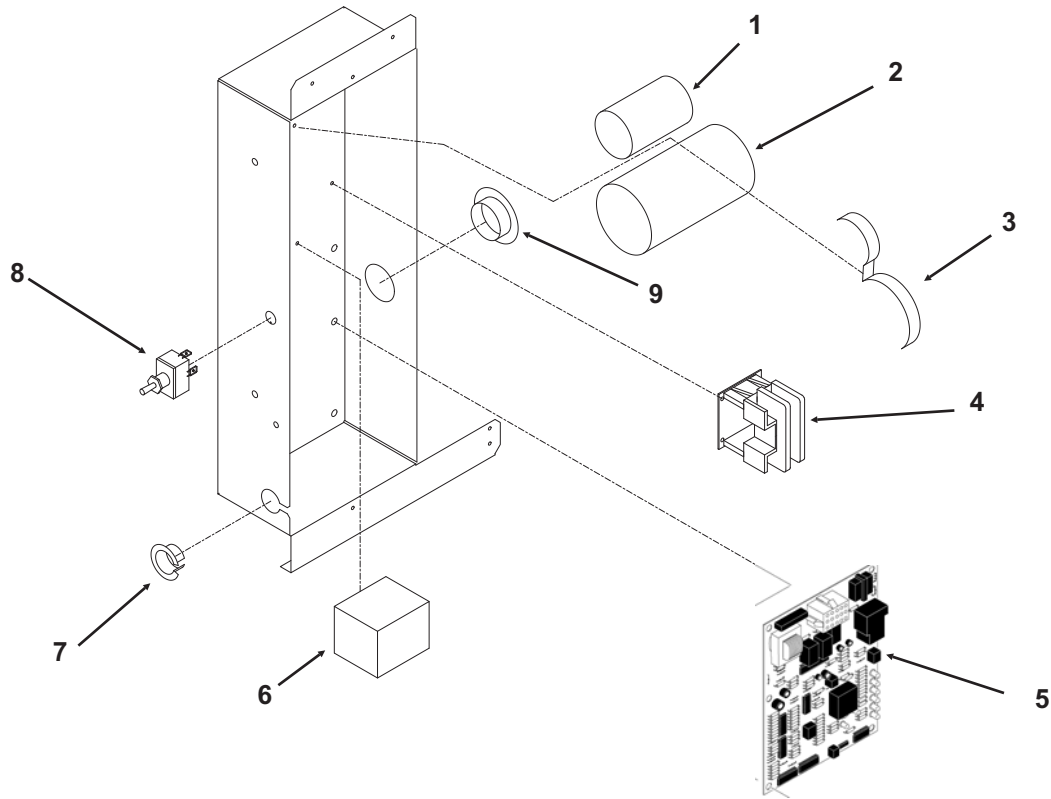

ITEM NUMBER	PART NUMBER	DESCRIPTION
1	1011447-82	Run capacitor, 115/60
	1011447-83	Run capacitor, 230/50
2	1011447-81	Start capacitor, 115/60
	1011447-80	Start capacitor, 230/50
	1011447-85	Cap for start capacitor
3	1011447-162	Capacitor strap
4	9101002-07	Contactor, 115v, 60 Hz
	9101002-06	Contactor, 230v, 50 Hz
5	1011447-59	60 Hz (115v) circuit board
	1011447-60	50 Hz (230v) circuit board
5a	1011447-53	Standoff for circuit board
6	1011447-84	Potential Relay, 115v, 60 Hz
	1011380-113	Potential Relay, 230v, 50 Hz
7	1011339-82	Bushing
8	1011339-78	Switch
9	1011447-105	Bushing

Not shown

10	1011447-163	Control box cover
11	1011447-50	Harness, AC
	1011447-51	Harness, WC

GEMD520 & GEMD540 SERVICE PARTS

Water System

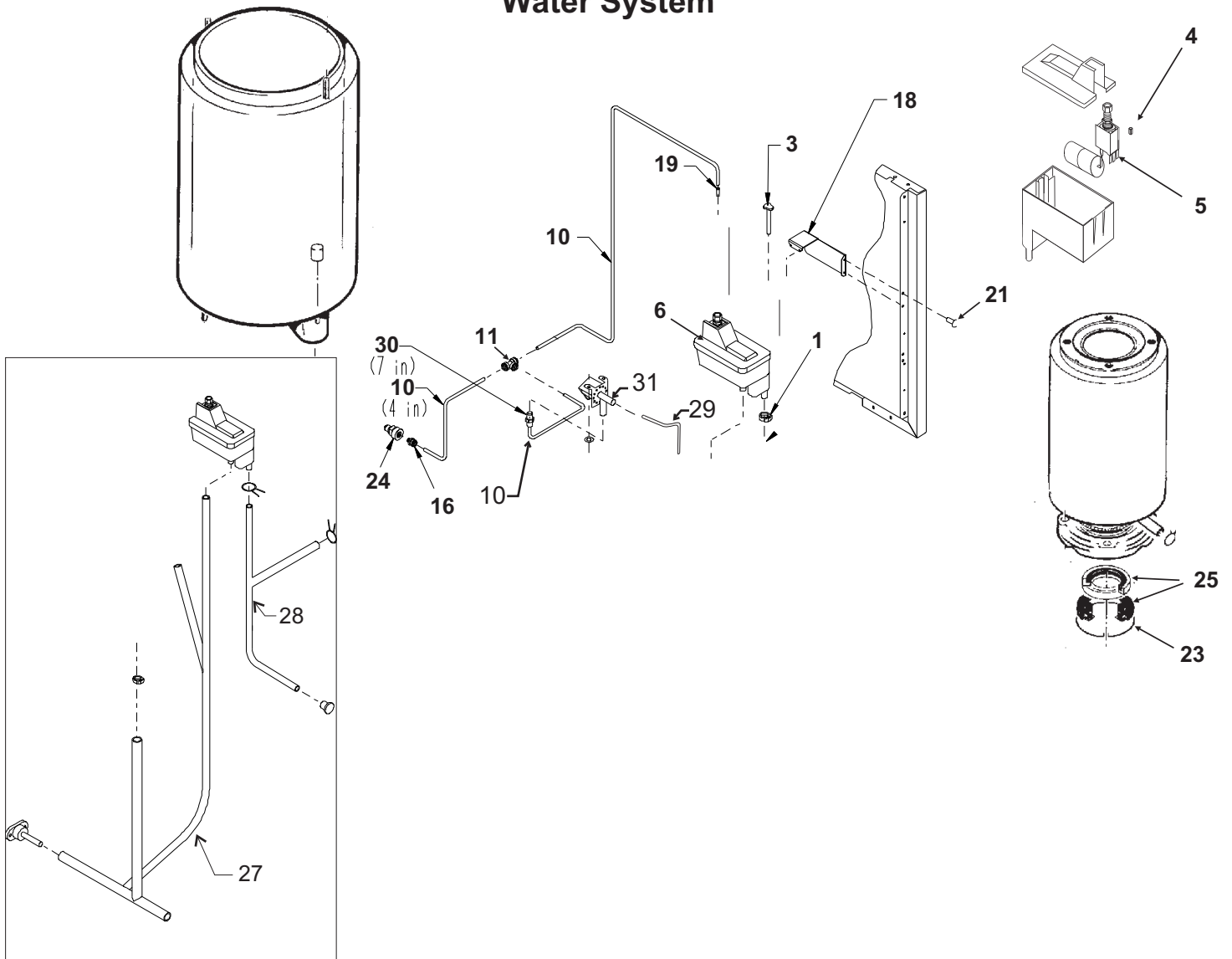

Changed 6/02

NUMBER	NUMBER	ITEM PART DESCRIPTION	NUMBER	NUMBER	DESCRIPTION
1	1011447-08	Clamp	18	1011447-181	Reservoir bracket
2	9051610-01	Plug	19	1011380-99	Brass insert
3	1011447-122	Water Level Sensor	20		
4	NA	Plunger/seat	21	9031046-27	Screw
5	NA	Float valve	22		
6	1011447-17	Reservoir Assy, complete	23	1011380-168	Retaining Ring
7			24	1011351-74	Inlet fitting for plastic
8			25	1011380-02	Water Seal
9			26		
10	3032898-40	Plastic tubing, order by foot	27	1011447-24	GEMD540 drain tube,
11	1011447-73	Tee union		1011447-187	GEMD520 drain tube,
12					
13			28	1011447-188	Reservoir inlet tubing
14	1011447-61	Bin Drain Tube, req. 15"	29	1011447-164	Water tube (SS) w/nut
15	1011447-22	Drain Casting	30	1011447-74	Female connector
16	1011351-75	Male connector	31	1011447-69	Inlet adapter
17					