

Ice-O-Matic[®]

Service Parts Manual GEMD790



GEMD790 SERVICE PARTS

This parts list contains the service parts and wiring diagrams for this model. Check the model number of the machine needing parts to be sure that this is the correct parts list.

Note: The liquid line filter drier listed in this parts list is designed for this refrigeration system. Premature failure may result if the wrong drier is used.

TABLE OF CONTENTS

Cabinet	PAGE 2
Hopper	PAGE 3
Sink	PAGE 4
Ice Chute and Dispensing	PAGE 5
Air Cooled Refrigeration	PAGE 6
Water Cooled Refrigeration	PAGE 7
Water System	PAGE 8
Evaporator	PAGE 9
Gearmotor	PAGE 10
Control Box	PAGE 11

GEMD790 SERVICE PARTS

Cabinet

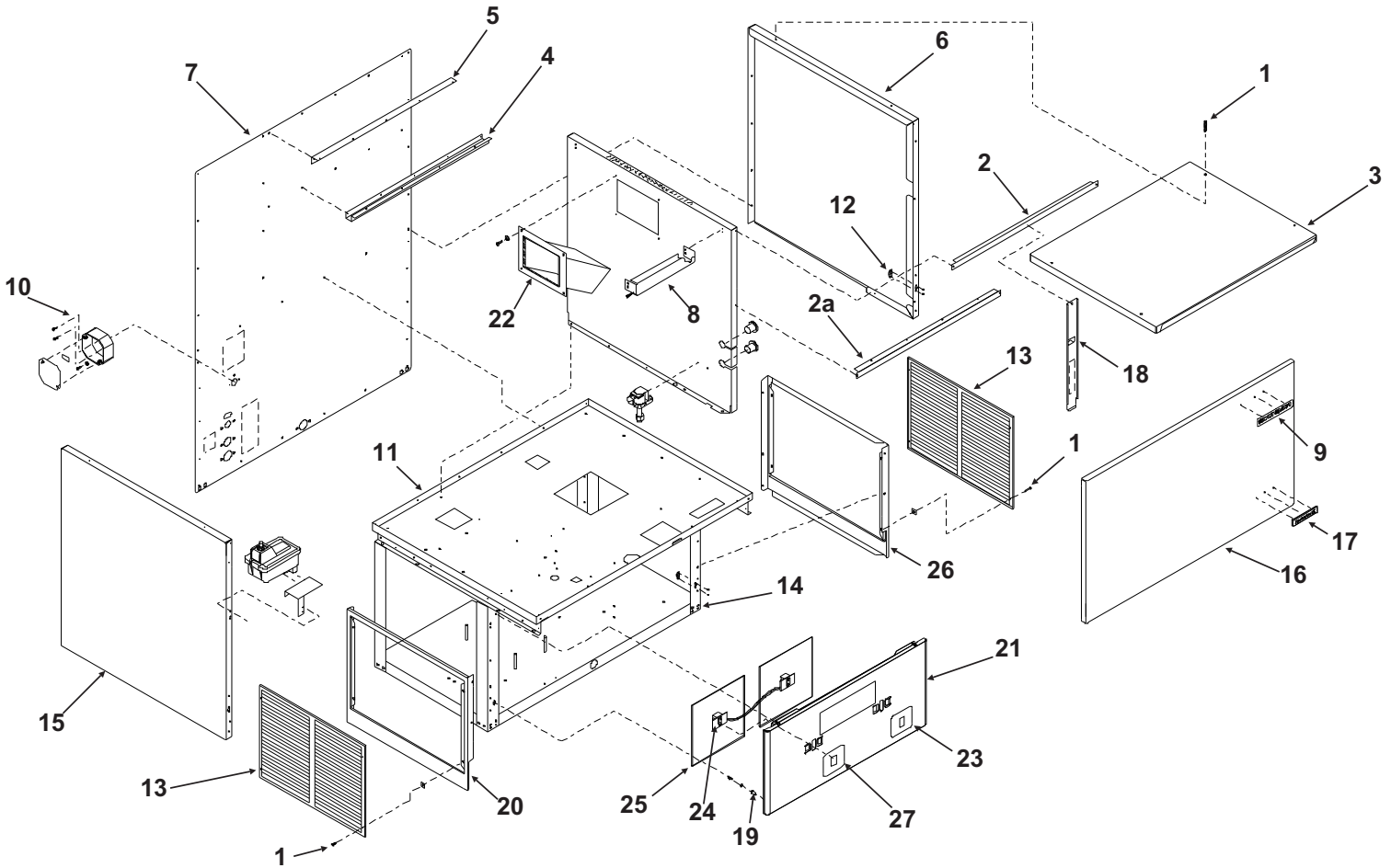

ITEM NUMBER	PART NUMBER	DESCRIPTION
1	9031045-07	S.S. Screw
2	1011447-153	Upper Brace
2a	1011447-152	Upper brace
3	1011447-139	Top panel, stainless
4	1011447-154	Bin support
5	1011447-130	Bin support brace
6	1011447-183	Rt. side upper panel
7	1011447-132	Back panel, stainless
8	1011447-129	Upper brace
9	9071974-01	Emblem
10	9031046-27	Screw
11	1011447-137	Upper Plate
12	1011447-39	Retainer for ball stud
13	1011447-134	Service Panel, stainless
14	1011447-133	Lower frame assy
15	1011447-182	Left side panel, upper
16	1011447-174	Upper front panel, s s
17	1011447-68	Emblem, Touch Free
18	1011447-157	Bracket
19	1011351-40	Ball stud
	1011447-39	Catch for stud (riveted to panel)
20	1011447-135	Lower left side panel
21	1011447-175	Splash panel
22	1011447-13	Ice chute
23	1011447-78	Touch free ice label
24	1011447-52	Sensor set
25	1011447-99	Insulation pad
26	1011447-136	Rt. side lower panel
27	1011447-79	Touch free water label

GEMD790 SERVICE PARTS

Hopper

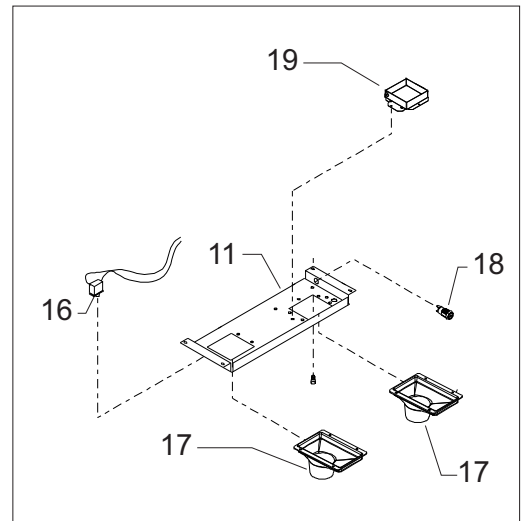
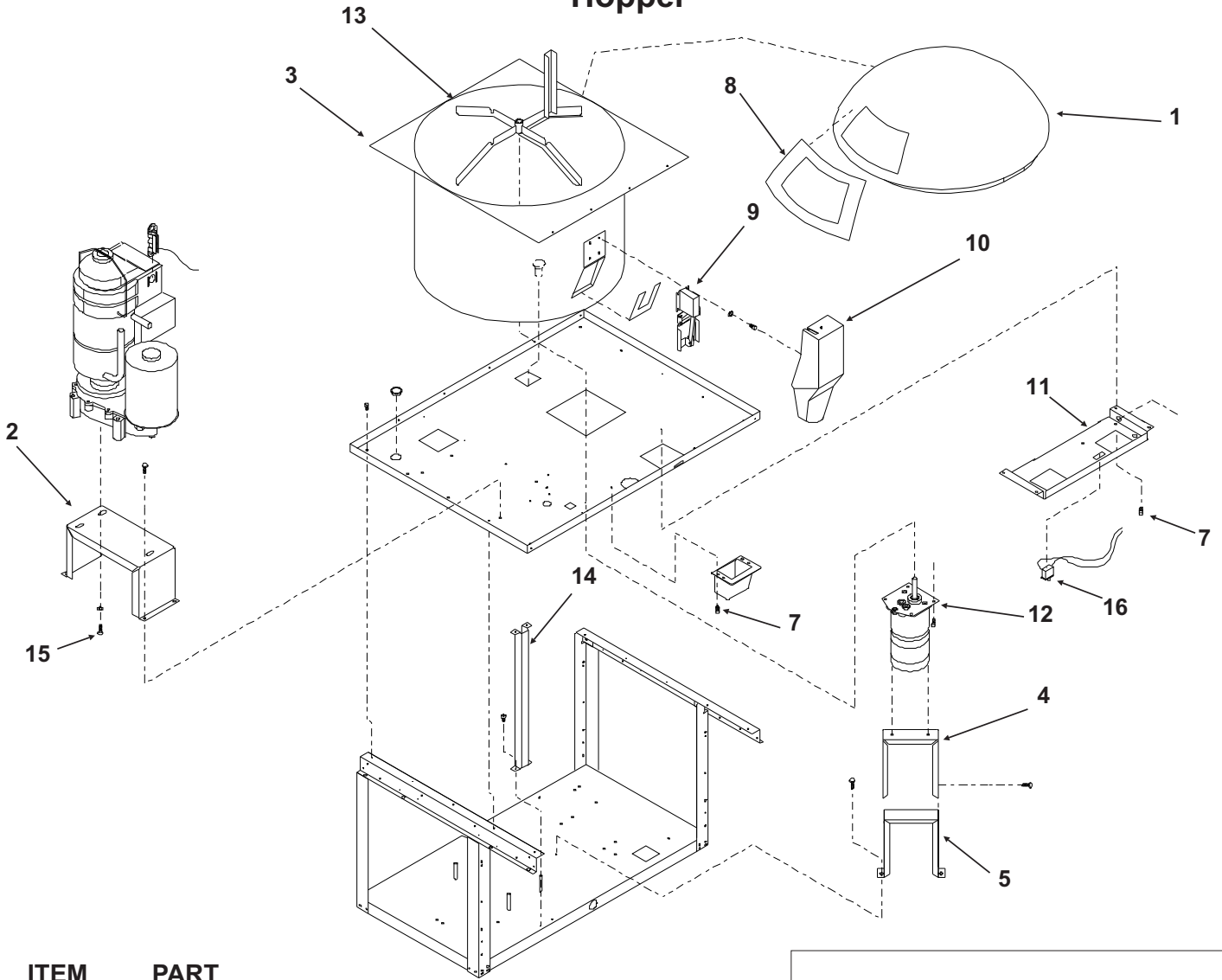

ITEM NUMBER	PART NUMBER	DESCRIPTION
1	1011447-156	Ice bin cover
2	1011447-138	Evap. support bracket
3	1011447-141	Ice Storage Bin
4	1011447-149	Agit mtr support, upper
5	1011447-150	Agit mtr support, lower
6		
7	9031046-27	Screw
8	1011447-67	Grommet
9	1011447-16	Door gasket
10	1011447-158	Ice chute
11	1011447-184	Bracket
12	1011447-48	Dispense motor assembly
	1011447-104	Heater for dispense gear motor
13	1011447-14	Agitator
14	1011447-131	Brace
15	1011447-29	Screw
16	1011447-54	Touch free disable switch
17	1011447-25	Spout
18	1011447-49	Switch
19	1011447-186	Chute extension

GEMD790 SERVICE PARTS

Sink

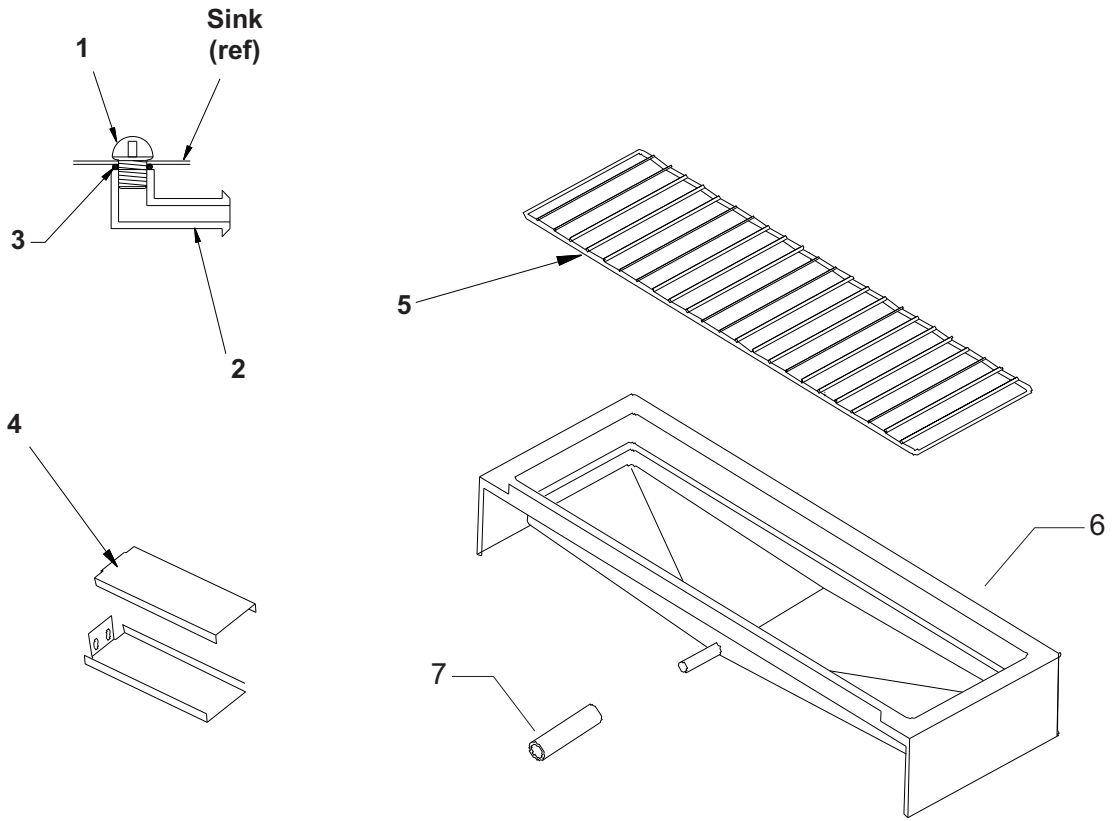

ITEM NUMBER	PART NUMBER	DESCRIPTION
1	1011339-18	Drain top
2	1011447-01	Drain btm
3	1011339-95	O-ring
4	1011447-145	Right sink support
	1011447-144	Sink support left
	1011339-74	Screw $\frac{1}{4}$ 20 x $\frac{1}{2}$ "
5	1011447-05	Grill
6	1011447-100	Sink assembly, includes items 1, 2 and 3.
7	1011447-64	Tube, need 33"

GEMD790 SERVICE PARTS

Ice Chute and Dispensing

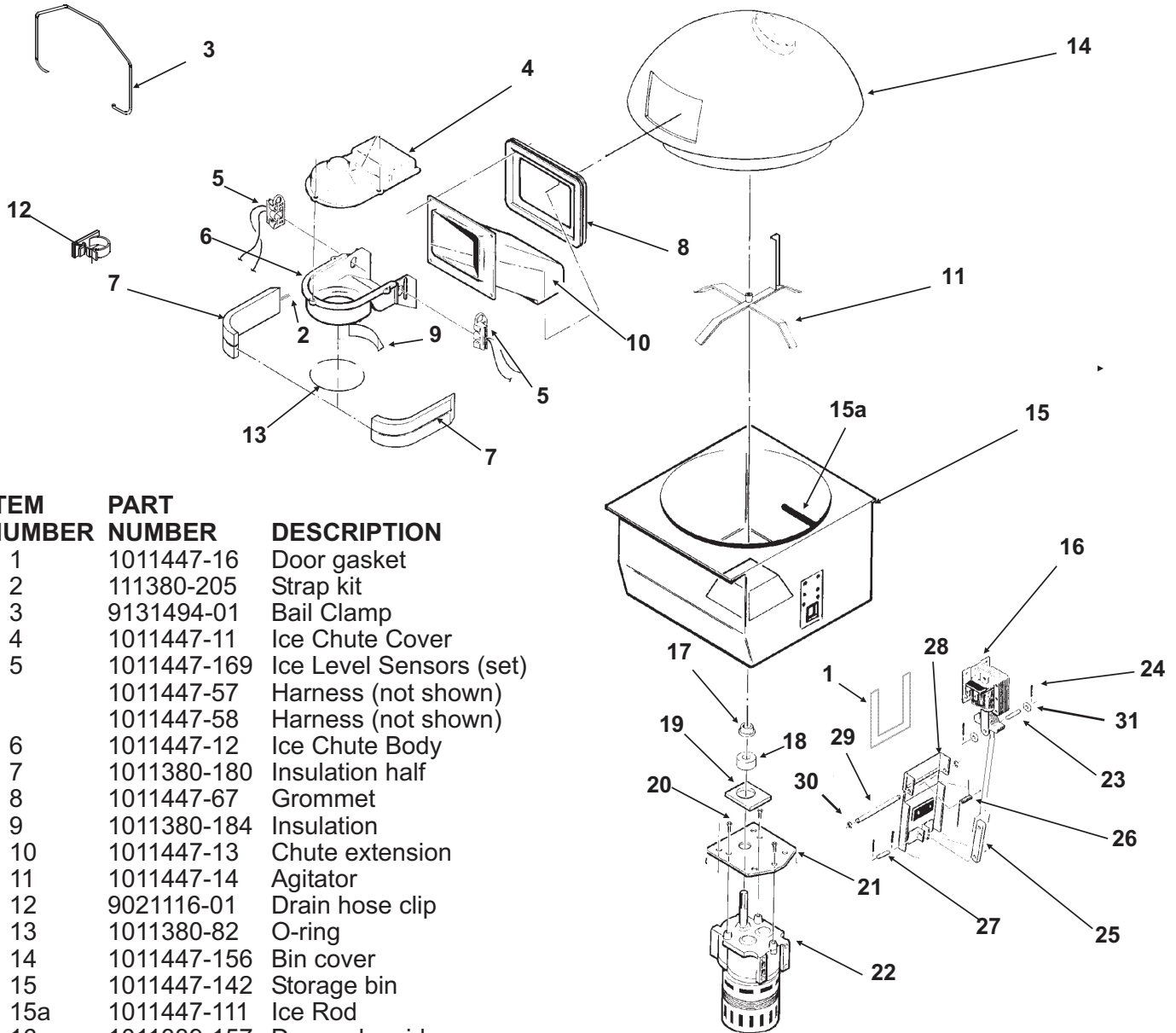

ITEM NUMBER	PART NUMBER	DESCRIPTION
1	1011447-16	Door gasket
2	111380-205	Strap kit
3	9131494-01	Bail Clamp
4	1011447-11	Ice Chute Cover
5	1011447-169	Ice Level Sensors (set)
	1011447-57	Harness (not shown)
	1011447-58	Harness (not shown)
6	1011447-12	Ice Chute Body
7	1011380-180	Insulation half
8	1011447-67	Grommet
9	1011380-184	Insulation
10	1011447-13	Chute extension
11	1011447-14	Agitator
12	9021116-01	Drain hose clip
13	1011380-82	O-ring
14	1011447-156	Bin cover
15	1011447-142	Storage bin
15a	1011447-111	Ice Rod
16	1011339-157	Door solenoid
17	1011447-110	Seal
18	1011447-109	Foam seal (round)
19	1011447-108	Foam seal
20	1011447-36	Screw
21	1011447-143	Plate
22	1011447-48	Gearmotor Assy
	1011447-104	Heater for gearmotor
23	1011339-158	Linkage pins, med.
24	1011339-153	Cotter pin
25	1011447-15	Solenoid linkage
26	1011339-159	Door spring
27	1011447-107	Linkage pins, small
28	1011447-112	Door
29	1011447-106	Long Axle
30	1011369-11	"C" Clip
31	1011339-52	Washer

GEMD790 SERVICE PARTS

Air Cooled Refrigeration

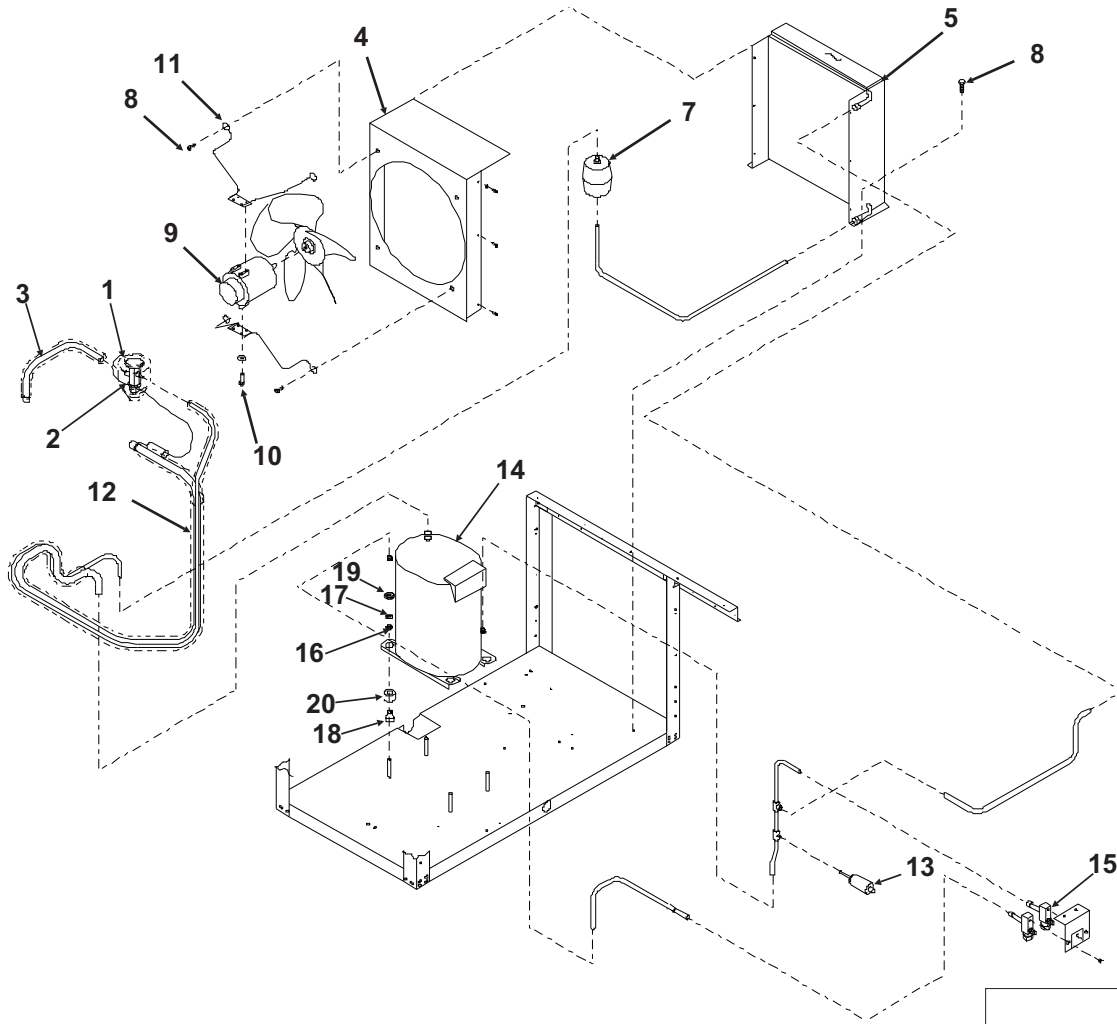

ITEM NUMBER	PART NUMBER	DESCRIPTION
1	1011447-27	Insulation
2	9151161-01	Thermo expansion valve
3	ref only	Evaporator inlet
4	1011447-159	Fan shroud
5	1011447-87	Condenser
6	1011380-120	Fan blade
7	9151163-03	Drier
8	1011339-74	Screw
9	1011447-86	Fan Motor
10	1011339-71	Screw
11	1011380-20	Fan motor bracket
12	1011447-160	Suction line
13	9041091-01	Hi press. cut out
14	1011447-96	Compressor
	1011447-97	Overload for above

ITEM NUMBER	PART NUMBER	DESCRIPTION
15		
16	1011339-53	Washer
17	1011339-63	Lockwasher
18	9181002-09	Grommet
19	1011447-31	Hex nut
20	9181002-02	Metal sleeve

15a1	1011380-94	Access valve seat
15a2	1011380-95	Access valve core
15a3	1011380-96	Cap

GEMD790 SERVICE PARTS

Water Cooled Refrigeration

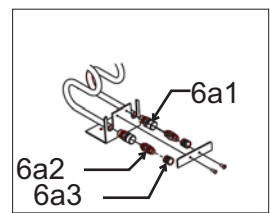
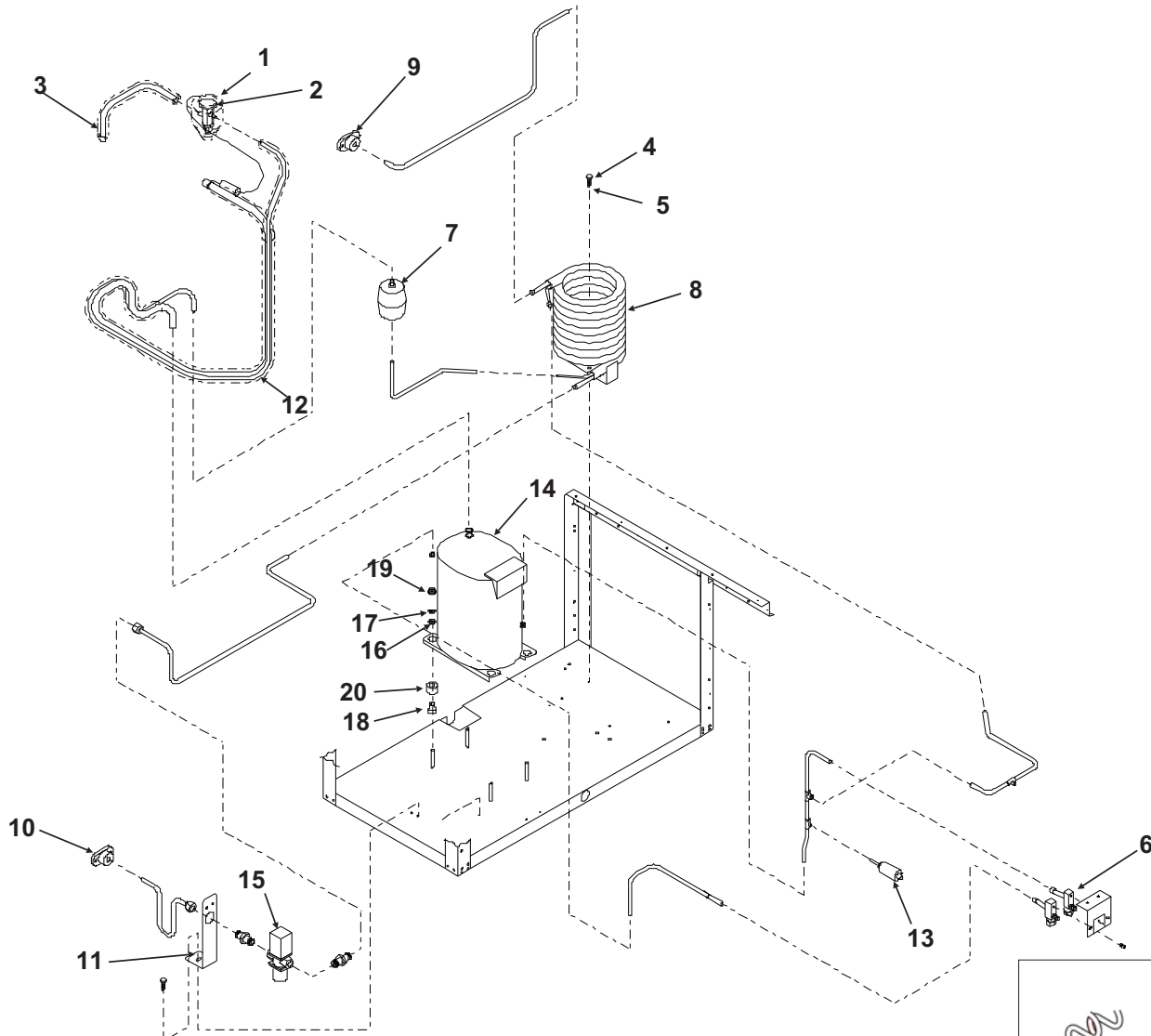

ITEM NUMBER	PART NUMBER	DESCRIPTION
1	1011447-27	Insulation
2	9151161-01	Thermo expansion valve
3	no number	Evap inlet tube
4	1011339-74	Screw
5	1011447-32	Washer
6		
7	9151163-03	Drier
8	9141141-01	WC condenser
9	1011447-75	Adaptor flange
10	1011447-76	Adaptor flange
11	1014447-140	Bracket
12	A35949-001	Suction line
13	9041091-01	Hi press. cut out
14	1011447-96	Compressor
	1011447-97	Overload for above

ITEM NUMBER	PART NUMBER	DESCRIPTION
15	1011447-41	Water reg. valve
16	1011339-53	Washer
17	1011339-63	Lockwasher
18	9181002-09	Grommet
19	1011447-31	Hex nut
20	9181002-02	Metal sleeve

Access valve		
6a1	1011380-94	Access valve seat
6a2	1011380-95	Access valve core
6a3	1011380-96	Cap

GEMD790 SERVICE PARTS

Water System

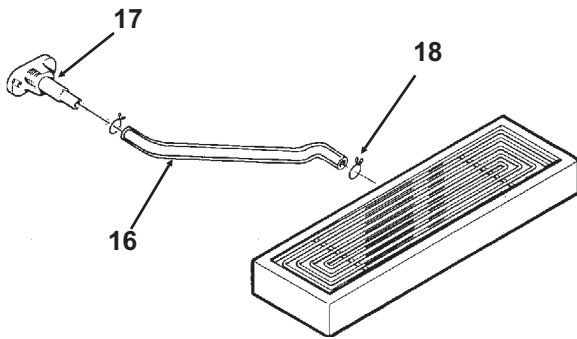
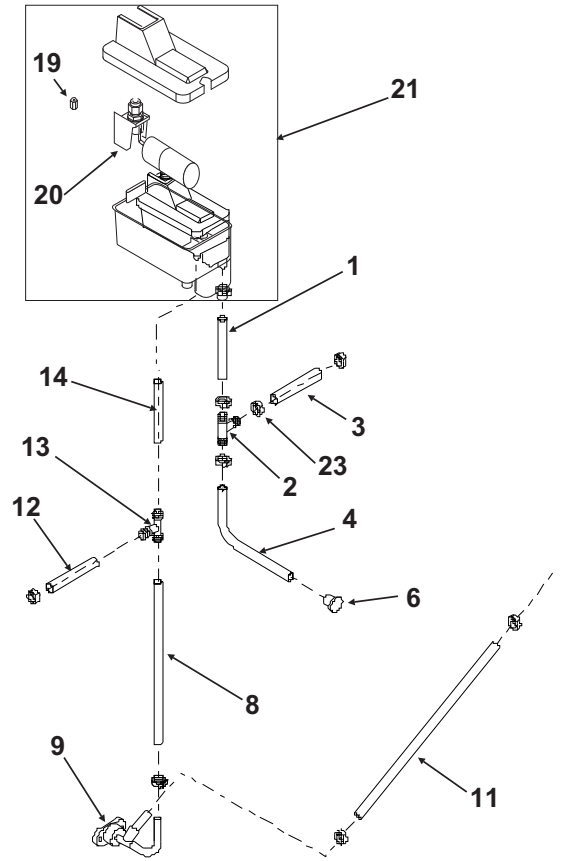
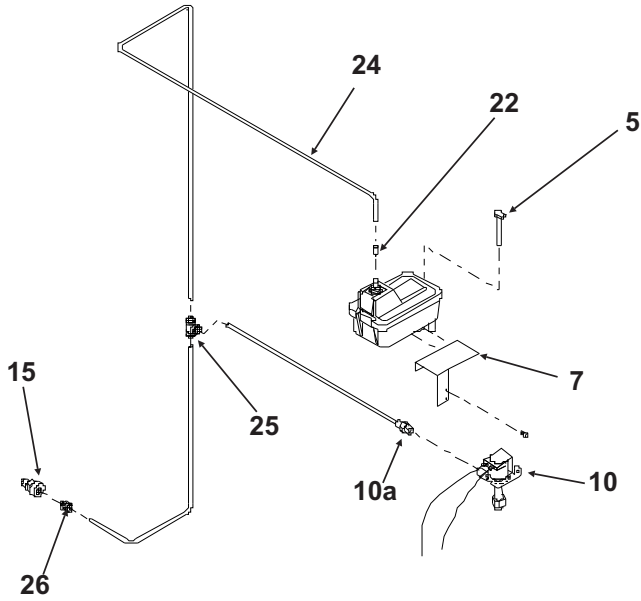

ITEM NUMBER	PART NUMBER	DESCRIPTION
1	1011447-63	Tubing, 11" req.
2	1011447-70	Tee
3	1011447-40	Evap. inlet tubing (preformed)
4	1011447-63	Tubing, 11" req.
5	1011447-122	Water sensor
6	9051610-01	Rubber plug
7	1011447-161	Reservoir bracket
8	1011447-62	Drain tubing, 25" req.
9	1011447-102	Drain assy
10	1011447-46	Inlet water valve
10a	1011447-74	Connector
11	1011447-63	Drain tubing 24" req.
12	1011447-62	Drain tubing 4" req.
13	1011447-71	Tee
14	1011447-62	Drain tubing 24" req.
15	1011351-74	Water inlet fitting
16	1011447-64	Sink drain tube 33" req.
17	1011447-23	Drain casting for sink drain
18	1011339-19	Hose clamp
19	N/A	Plunger/seat
20	N/A	Float valve
21	1011447-21	Reservoir, incl 19, 20
22	1011380-99	Insert
23	1011351-03	Hose clamp
24	3032898-40	Hose
25	1011447-73	Tee
26	1011351-75	Connector

GEMD790 SERVICE PARTS

Evaporator

ITEM NUMBER	PART NUMBER	DESCRIPTION
1	1011380-43	Cap Screw
	1011447-34	Lockwasher
2	1011382-09	Evaporator
3	1011447-108	Insulation half
4	1011380-179	Insulation half
5	1011380-02	Water seal
6	1011380-168	Retaining ring for seal
7	1011380-27	Drip pan

ITEM NUMBER	PART NUMBER	DESCRIPTION
8	1011380-83	Gasket
9	1011380-85	Water shed
10	1011380-10	Lip Seal
11	1011380-82	O-Ring
12	1011380-175	Breaker (incl. 10, 11, 14, 22, 17, 18, 19, 20)
13	1011380-44	Soc. head screw
14	1011380-80	O-ring
15	1011380-38	Hex cap screw
16	9051603-01	Ice sweep
17	1011380-86	Water shed
18	1011380-11	Lip seal
19	1011380-13	Breaker cover
20	1011380-81	O-ring
21	1011380-46	Auger stud
22	1011380-202	Bearing
23	1011380-225	Auger

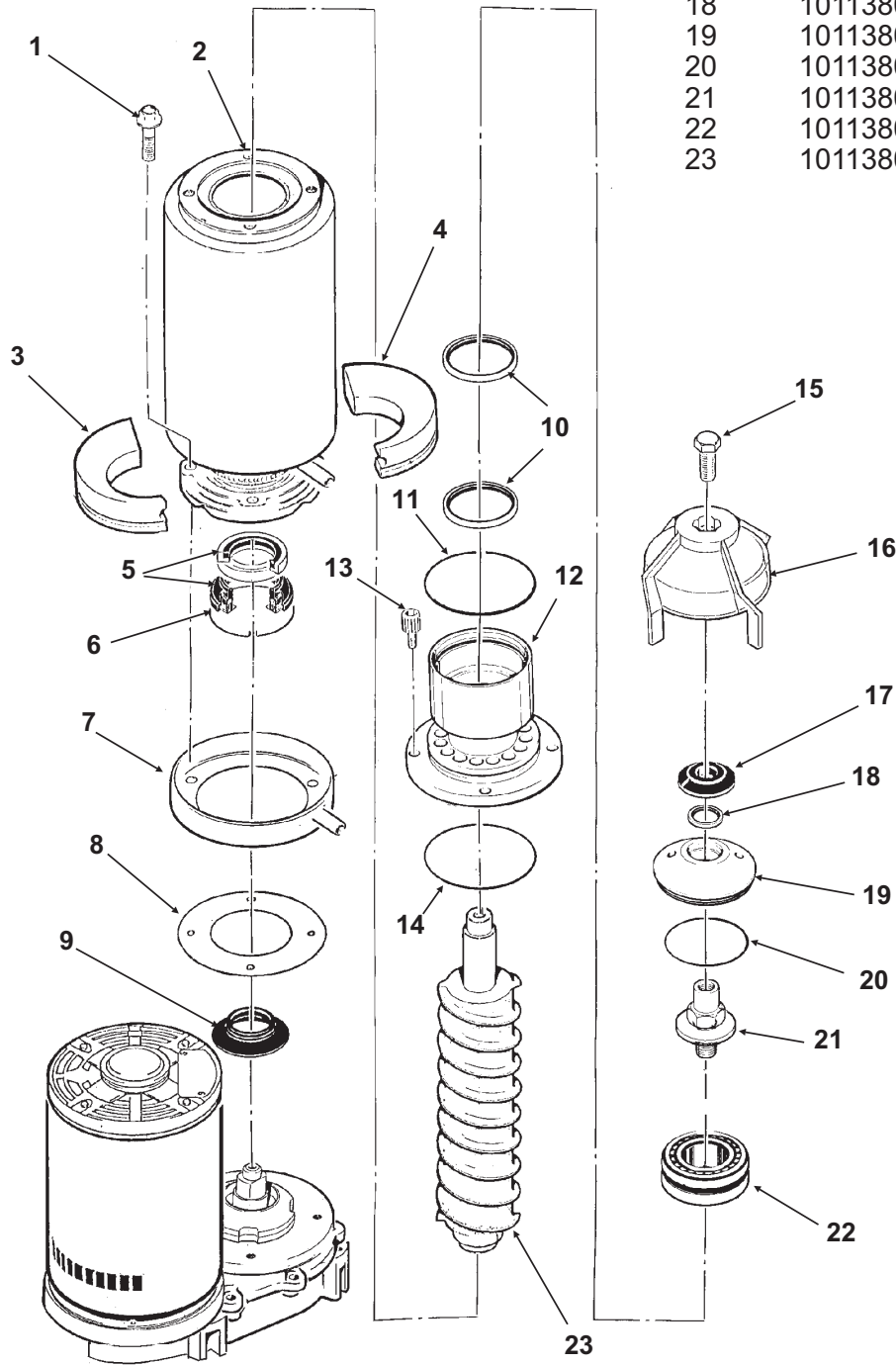

GEMD790 SERVICE PARTS

Gearmotor

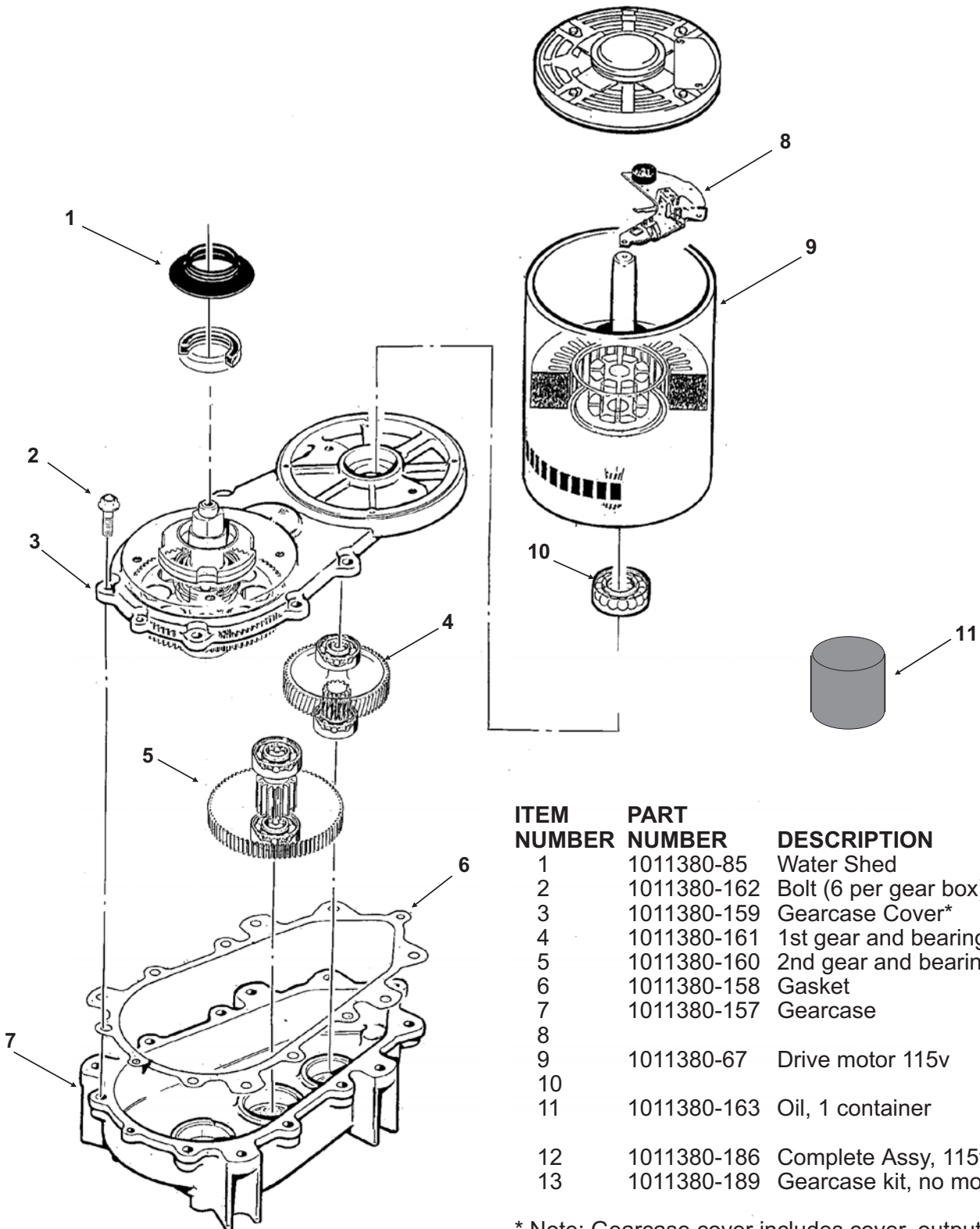

ITEM NUMBER	PART NUMBER	DESCRIPTION
1	1011380-85	Water Shed
2	1011380-162	Bolt (6 per gear box)
3	1011380-159	Gearcase Cover*
4	1011380-161	1st gear and bearings
5	1011380-160	2nd gear and bearings
6	1011380-158	Gasket
7	1011380-157	Gearcase
8		
9	1011380-67	Drive motor 115v
10		
11	1011380-163	Oil, 1 container
12	1011380-186	Complete Assy, 115v
13	1011380-189	Gearcase kit, no motor

* Note: Gearcase cover includes cover, output shaft, key, output gear, bearings and seal.

GEMD790 SERVICE PARTS

Control Box

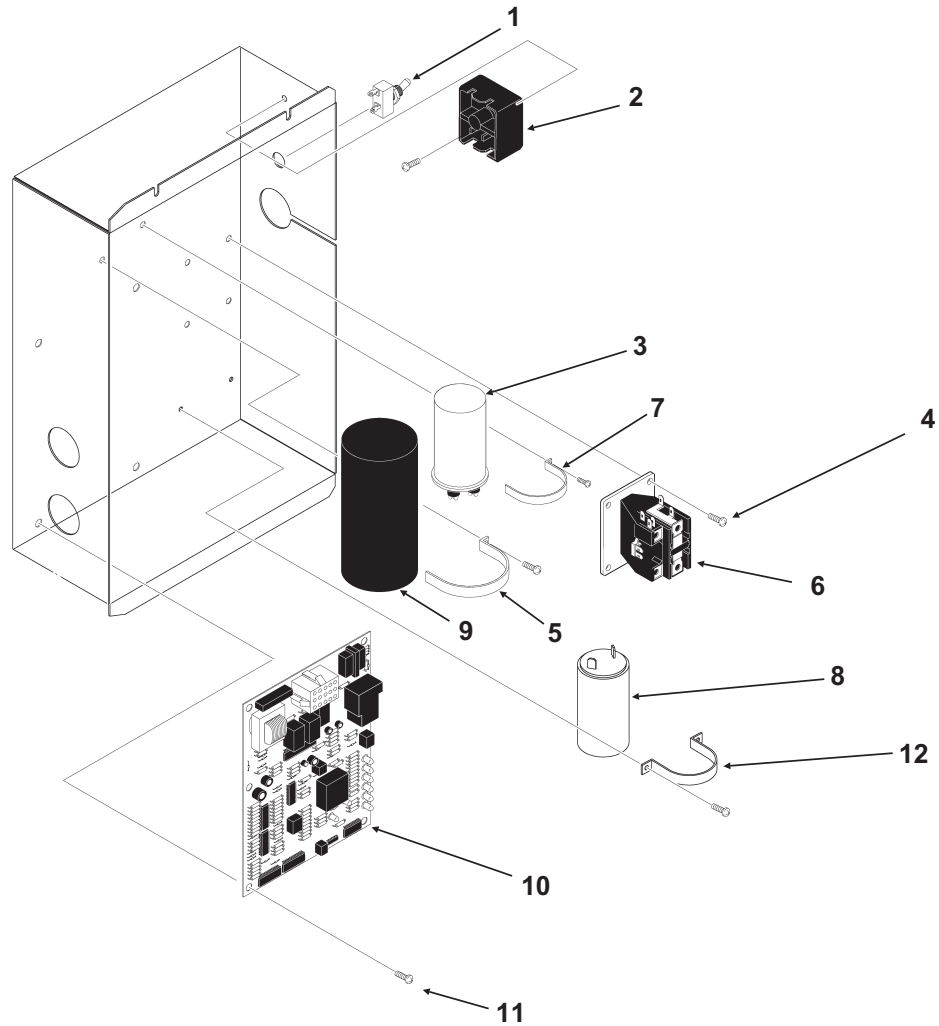

ITEM NUMBER	PART NUMBER	DESCRIPTION
1	1011339-78	Toggle switch
2	1011447-84	Start relay,
3	1011447-82	Run capacitor for compressor,
4	9031046-27	Screw
5	3013381-01	Capacitor bracket
6	9101002-07	Contactors 115v
7	3013381-01	Capacitor bracket
8	1011339-103	Run capacitor-bin drive motor
9	1011447-81	Start capacitor
10	1011447-59	Circuit board
11	1011447-128	Standoff

NOT ILLUSTRATED
 12 1011447-151 Control box cover