



# SPA-160 • SFA-191 Ice Dispensers

Model

SPA-160     SFA-191

**ONLY 22" WIDE**

### SPA Model

Designed for ice bucket filling in hotels, motels, and resorts

Ice only dispense, with coin-op and room card dispensing control options



S-Series 422 Ice Machine  
SPA-160 Ice Dispenser

### SFA Model

Designed for "large" container ice filling. Accepts up to 10.5" (26.67 cm) high container

Built-in water valve



S-Series 422 Ice Machine  
SFA-191 Ice & Water Dispenser



## Standard Features

- 120 lbs. (54.4 kgs.) ice storage capacity. Accepts 22" (55.88 cm) wide Manitowoc ice machine.
- Only 22" (55.88 cm) wide, 31" (78.7 cm) deep, and 75.5" high (191.77 cm).
- Patented rocking chute dispense mechanism reduces in-flight ice and ice spillage with quick on/off activation.
- Efficient built-in agitator assures 100% dispensing. Oversized drain pan collects larger quantity of ice overflow.

## Warranty

- 5-year parts and 5-year labor coverage on ice machine evaporator.
- 5-year parts and 3-year labor coverage on ice machine compressor.
- 3-year parts-and-labor coverage on all other ice machine and dispenser components.

## Ice Shape



**Half Dice**  
3/8" x 1 1/8" x 7/8"  
(.95 x 2.86 x 2.22 cm)



**Dice**  
7/8" x 7/8" x 7/8"  
(2.22 x 2.22 x 2.22 cm)



QUALITY MANAGEMENT SYSTEM  
CERTIFIED BY DNV  
ISO 9001:2008



# SPA-160 • SFA-191 Ice Dispensers

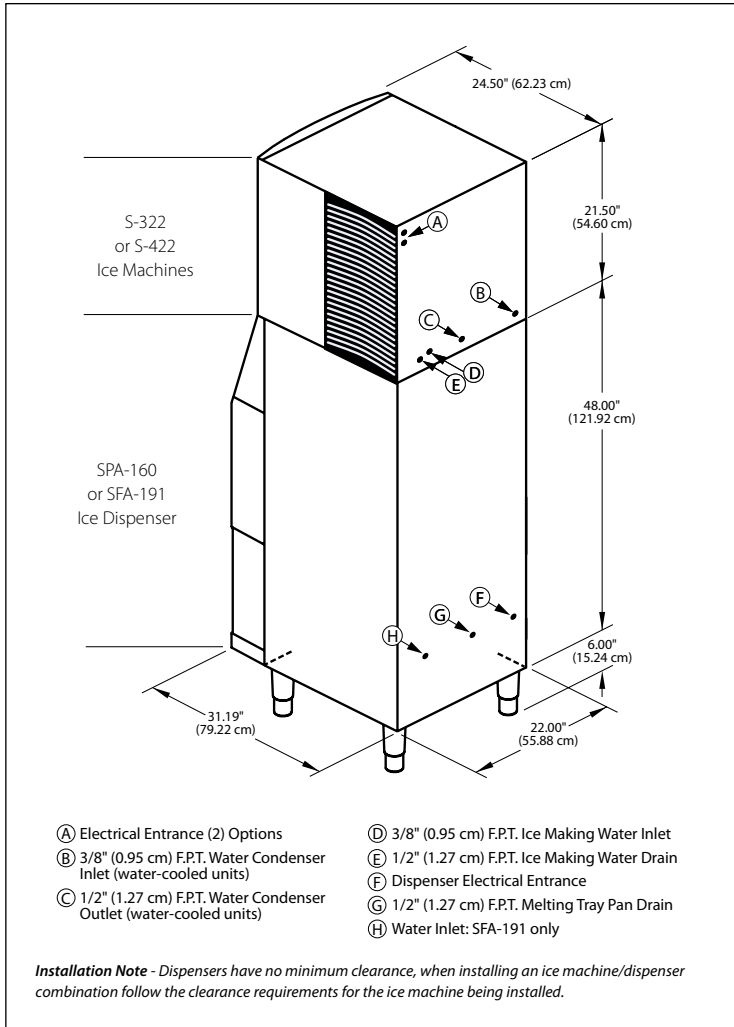

## Ice Machine Electric

**Note:** Dispenser will accept single 22" wide ice machine. Ice machine ordered separately. Choose Dice or Half Dice cube size. Refer to ice machine specification sheet for electrical and complete AHRI standard ratings.

### Dispenser Electric:

115/60/1. (208-230/60/1 and 230/50/1 also available.)

### Maximum Circuit Fuse Size:

15.0 amps. HACR-type circuit breakers can be used in place of fuses.

### Dispenser Electrical Connection:

6' power cord, rated 125 VAC, 16-3 conductors with standard 3-prong, straight-blade, ground-type plug (NEMA configuration 5-15P).

### Motor:

1.6 amps maximum. Permanently lubricated.

### Service Access:

Dispenser door removes easily to access components.

### Model Options:

SPA-160 push-for-ice rocking chute, SCA-163 coin-op and SRA-164 room card control available. To field-convert SPA-160 to SRA-164, call factory for information. SFA-191 has a water valve option.

### Series 322 (115 volt)

Model	Ice Shape	Ice Production 24 Hours			
		70°Air/50°F Water		90°Air/70°F Water	
		lbs.	kgs.	lbs.	kgs.
SD-0322A	dice	340	154	270	113
SD-0323W	dice	330	150	290	132
SY-0324A	half-dice	340	154	270	113
SY-0325W	half-dice	330	150	290	132

### Series 422 (115 volt)

Model	Ice Shape	Ice Production 24 Hours			
		70°Air/50°F Water		90°Air/70°F Water	
		lbs.	kgs.	lbs.	kgs.
SD-0422A	dice	430	195	320	145
SD-0423W	dice	430	195	370	168
SY-0424A	half-dice	460	209	355	161
SY-0425W	half-dice	435	197	370	168

### AuCS®SO Accessory



Automatic Cleaning System purchased as an option and installed in the field.

### Options for SPA-160:

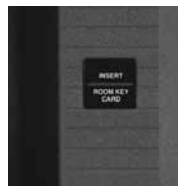

Room Card  
SRA-164



Coin-Op  
SCA-163  
25-cent coin  
standard.