

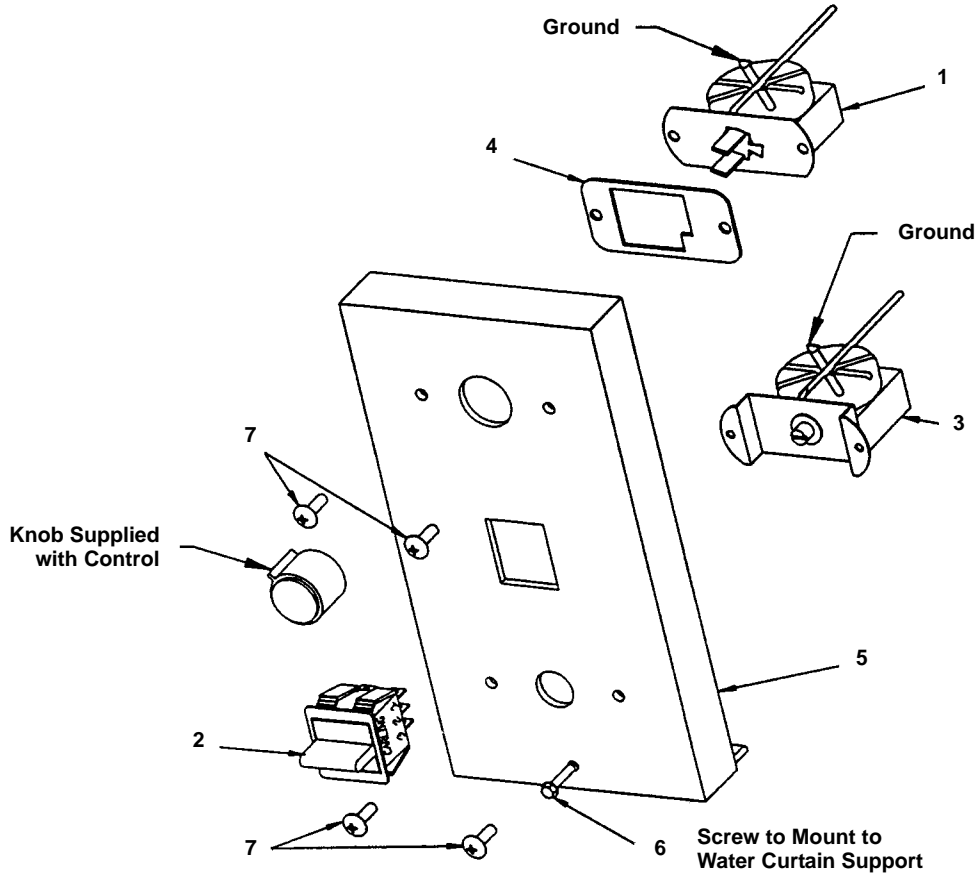

Ice Machine Parts List for Series I-25

I-25 CONTROL BOX



PT1107

		115V/60	230V/50	230V/60
1	Cube size control	† 76-2613-3	same	same
2	Switch - toggle	23-0146-3	same	same
3	Bin thermostat	23-5126-3	same	same
4	Stop - cube size control	600898-1	same	same
5	Control box cover	76-2614-3	same	same
6	Screw, 8-18 x 5/8 hex	† 50-1225-9	same	same
7	Screw, 8-32 x 1/2 phil	† 50-2624-9	same	same
8	Power Cord (Not shown)	No Longer Available	20-3188-3	No Longer Available

† Refer to Cross Reference Guide

I-25 EVAPORATOR COMPARTMENT

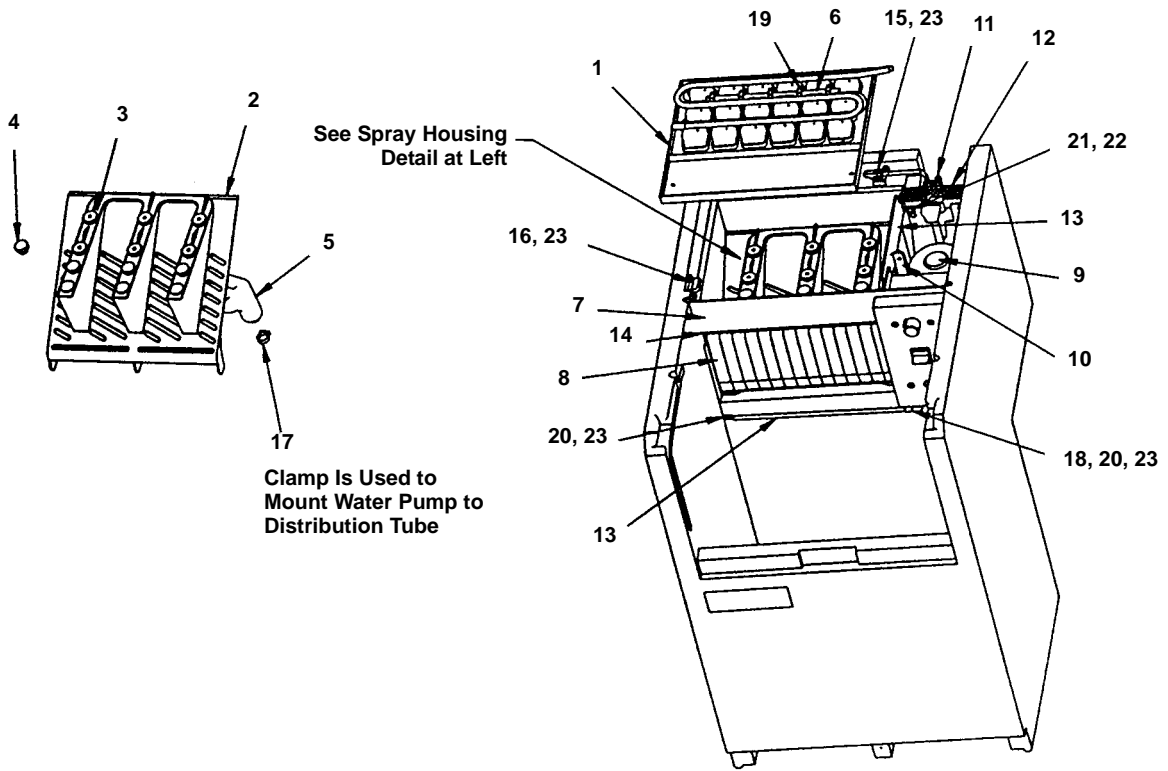

PT1108

	115V/60	230V/50	230V/60
1 Evaporator, 18 cube, assy	No Longer Available	same	same
2 Spray assembly	† 76-2616-3	same	same
3 Spray nozzle (uses 6)	No Longer Available	same	same
4 Water plug	† 43-0062-9	same	same
5 Distribution tube - vinyl molded	44-2092-3	same	same
6 Thermal tube (for cube size ctl)	44-0869-3	same	same
7 Water curtain support	43-0253-3	same	same
8 Water curtain flap (uses 14)	43-0251-3	same	same
9 Water pump	† 76-2552-3	† 14-8027-9	† 14-8027-9
10 Standpipe (near water pump)	† 43-0272-3	same	same
11 Vent, sump (behind water pump)	600887-1	same	same
12 Water pump lead	No Longer Available	same	same
13 Sump divider	600546-1	same	same
14 Rod for water curtain flaps	56-1030-3	same	same
15 Clip - evap/water tube	43-0268-3	same	same
16 Clip - evaporator	No Longer Available	same	same
17 Clamp (on water pump)	† 56-5053-9	same	same
18 Clamp on vinyl tube	† 56-5003-9	same	same
19 Clamp to hold thermal tube	No Longer Available	same	same
20 Spacer	† 43-0274-9	same	same
21 Lockwasher	† 55-4516-9	same	same
22 Screw, 10-32 x 3/8	† 50-2707-9	same	same
23 Screw, 8-18 x 5/9	† 50-1225-9	same	same
24 Water Shield - Mylar	601909-1	same	same

† Refer to Cross Reference Guide

I-25 COMPRESSOR COMPARTMENT

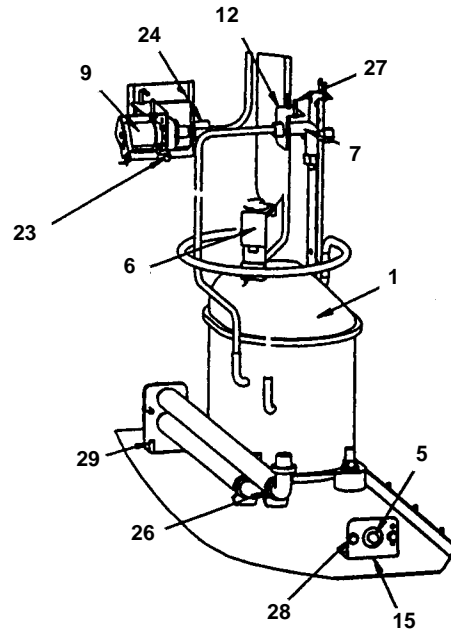
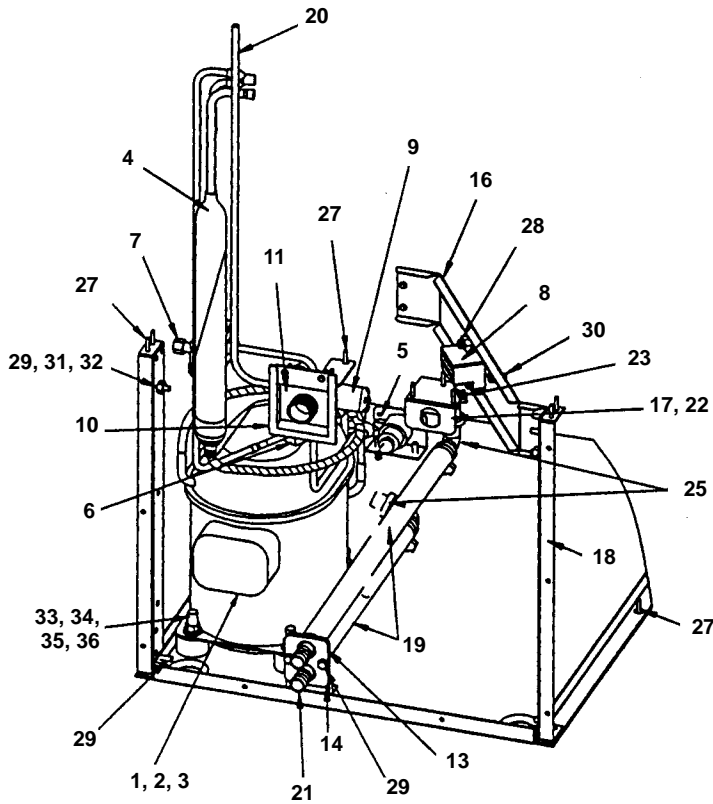

PT1104

	115V/60	230V/50	230V/60
1 Compressor 115V 60 Hz	No Longer Available	† 76-2619-3	† 76-2620-3
2 Overload	85-0471-3	85-0473-3	85-0508-3
3 Relay	85-0472-3	85-0474-3	85-0509-3
4 Cap tube/heat exch assy 1-25	76-2618-3	same	same
5 High pressure cutout control	† 23-5536-9	same	same
6 Hot gas solenoid valve (Danfoss)	† 76-3000-1	† 76-3006-1	† 76-3006-1
7 Service valve	† 83-7310-9	same	same
8 Terminal board	25-1109-3	same	same
9 Water inlet valve	24-0507-3	No Longer Available	No Longer Available
10 Water inlet splash guard	43-0269-3	same	same
11 Bracket, inlet support	601094-1	same	same
12 Bracket, service valve	601277-1	same	same
13 Bracket, drain	600895-1	same	same
14 Bracket, locking drain	600894-1	same	same
15 Bracket, high pressure control	601060-1	same	same
16 Bracket, upper shroud	600767-1	same	same
17 Bracket, strain relief	600976-1	same	same
18 Corner support	† 601804-1	same	same
19 Tubing, vinyl, .625 ID	† 44-2038-3	same	same
20 Tubing, poly, .025 OD	44-2029-1	same	same
21 Drain fittings	83-9015-3	same	same
22 Bushing, strain relief	25-1204-3	25-1206-3	25-1204-3
23 Clip, blade grounding	25-1110-3	same	same
24 Ferrule nut on water inlet valve	† 56-5072-9	same	same
25 Elbow, 90D black poly (uses 2)	No Longer Available	same	same
26 Plastic clamp	† 56-5060-9	same	same
27 Screw, 8-18 x 5/8	† 50-1225-9	same	same
28 Screw, #8 x 3/4	† 51-2166-9	same	same
29 Screw, 10-24 x 1/2	† 52-0206-9	same	same
30 Screw, 10-24 x 1/2	† 52-0216-9	same	same
31 Washer, #10, lock	† 55-4516-9	same	same
32 Hexnut 10-24 x 3/8	† 54-2929-9	same	same
33 Rubber Grommet	† 85-0306-9	same	same
34 Flatwasher 5/16	† 55-7309-9	same	same
35 Hexnut 3/8 x 16	54-3002-9	same	same
36 Sleeve 3/8 x 1	† 85-0394-9	same	same
37 Reducer (sent w/unit)(Not shown)	87-0404-3	same	same

† Refer to Cross Reference Guide

I-25 AIR-COOLED

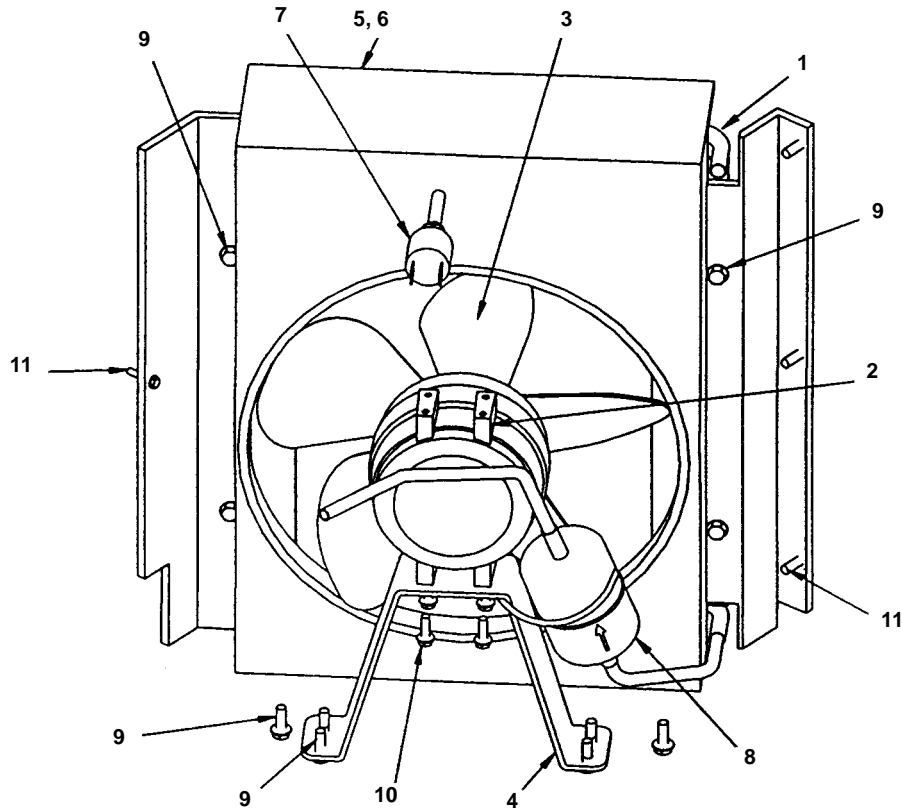

PT1105

	115V/60	230V/50	230V/60
1 Air condenser *	88-5122-3	same	same
2 Fan motor 115V 60 Hz	† 24-1287-3	† 24-1288-3	† 24-1288-3
3 Fan blade	† 24-1602-1	same	same
4 Fan bracket	600803-1	same	same
5 Fan shroud (metal)	600869-1	same	same
6 Fan shroud (fiberboard)	71-1174-3	same	same
7 Fan cycling control	23-5538-3	same	same
8 Drier	† 89-3025-9	same	same
9 Screw, 10-24 x 1/2	† 52-0206-9	same	same
10 Screw, 8-38 x 7/16	† 50-2559-9	same	same
11 Screw, 8-18 x 5/8	† 50-1225-9	same	same

* When ordering air condenser for units prior to SN 961061802, you must order fiberboard shroud # 71-1174-3.

I-25 WATER-COOLED

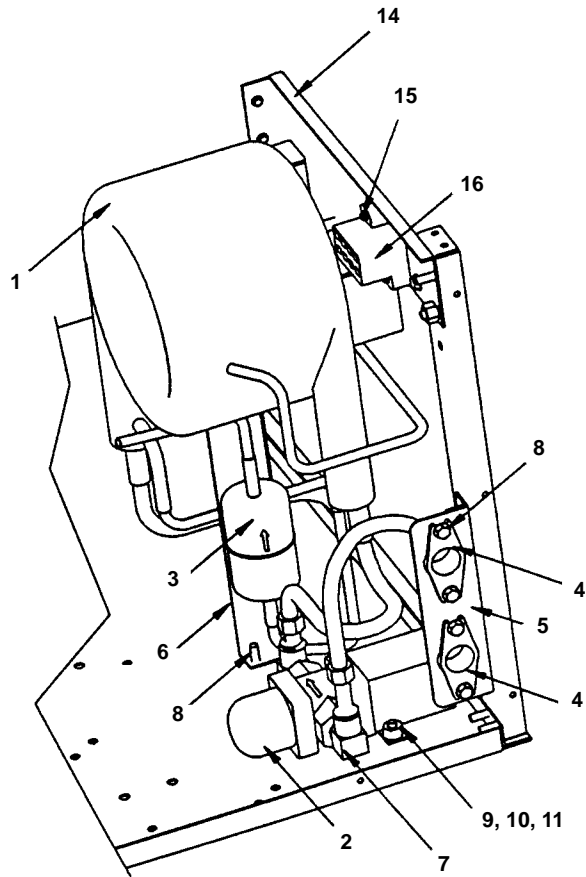
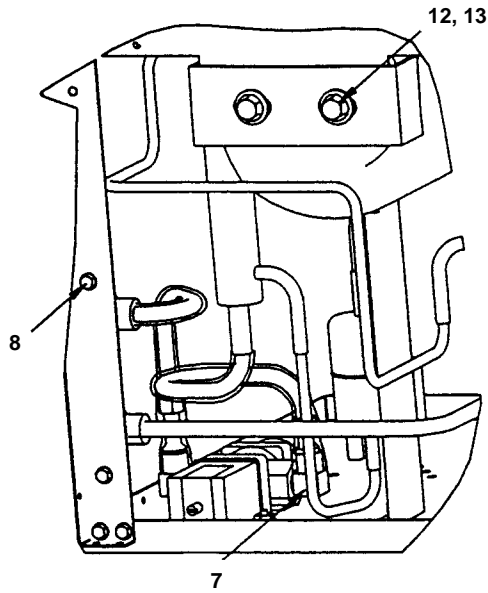

PT1106

	115V/60	230V/50	230V/60
1 Water condenser	88-6522-3	same	same
2 Water regulating valve	83-7213-3	same	same
3 Drier	† 84-3022-9	same	same
4 Adapter, 1/2 x 3/8	87-0610-3	same	same
5 Bracket for adapter	600974-1	same	same
6 Bracket for drier	600975-1	same	same
7 Elbow, half union	No Longer Available	same	same
8 Screw, 10-24 x 1/2	† 52-0206-9	same	same
9 Washer, #10 lock ext teeth	† 55-4516-9	same	same
10 Screw 10-32 x 1/2	† 50-2702-9	same	same
11 Hex nut 10-32	† 54-2943-9	same	same
12 Washer	† 55-7309-9	same	same
13 Screw, 1/4 x 20	50-3568-3	same	same
14 Bracket to mount condenser	601317-1	same	same
15 Screw, #8 x 3/4	† 51-2166-9	same	same
16 Terminal board	25-1109-3	same	same

† Refer to Cross Reference Guide

I-25 CABINET

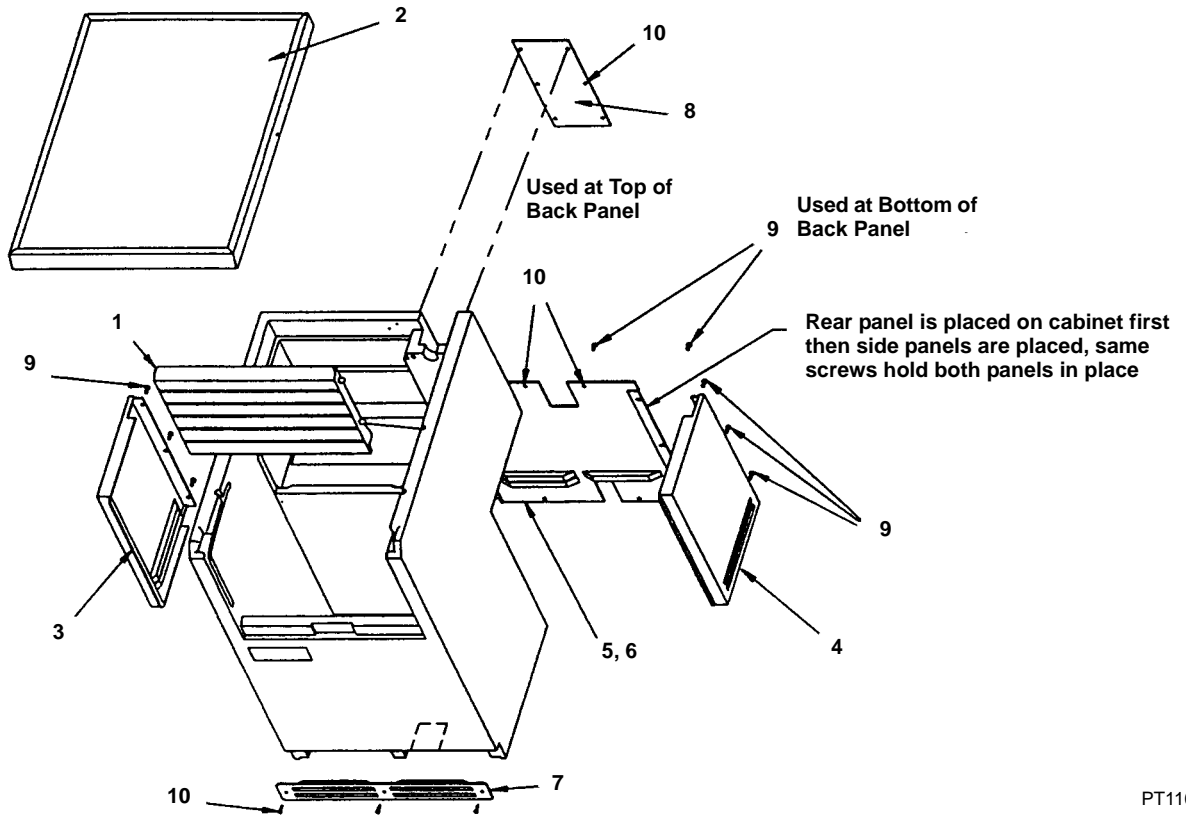

PT1109

1	Door	43-9510-3
2	Top cover	43-9512-3
3	Panel, Side LH	† 601294-1
4	Panel, Side RH	† 601293-1
5	Panel, rear, air cooled	† 601279-1
6	Panel, rear, water cooled	† 601438-1
7	Grill, front, vacuum formed	600804-1
8	Panel, tubing	601019-1
9	Screw, 10-24 x 1/2	† 52-0206-9
10	Screw, 8-18 x 5/8	50-1225-3
11	Ice Scoop (Not shown)	330256-3

INTENTIONALLY LEFT BLANK