

Metro[®] Heated Banquet Cabinets

TOP-MOUNTED MODULE USER MANUAL



InterMetro Industries Corporation
Wilkes-Barre, PA 18705
570-825-2741



TABLE OF CONTENTS

SECTION	PAGE
I. Introduction	
A. Identifying Your Cabinet	2
B. Features	3
II. Operating Instructions	
A. Electric Heating System	3
B. Canned Fuel System	3
C. Count-up/Count-down Timer/Clock	3
III. Cleaning Instructions	
A. Shelf Removal/Installation	4
B. Electric Heating Module Removal/Installation	4
C. Quad-Heat Dual Fuel Removal/Installation	4
D. Specific Cleaning Instructions	5
E. General Cleaning Instructions	5
IV. Maintenance	
A. Cabinet Maintenance	5
B. Electric Heating Module	5
C. Blower Motor Maintenance	5
V. Replacement Parts and Procedures	
A. Cabinet	6
B. Electric Heating Module	8
C. Battery Replacement — Count-up/Count-down Timer/Clock	8
D. Swivel-Lock Operation	8
E. Swivel-Lock Caster System	11
F. Quad-Heat System	12
VI. Wiring Schematic	13
Warranty	14

I. INTRODUCTION

A. IDENTIFYING YOUR CABINET

There are two numbers, which you may want to record for future reference: the cabinet model number, serial number, and the module serial number. Refer to the photo below to locate these numbers. It is recommended that all numbers be recorded in an appropriate place, such as on this page (see below). Also, please record the cabinet model number and module serial number on the Warranty Card found at the back of this manual. Be sure to complete the remainder of the Warranty Card and return it to Metro within fifteen (15) days of delivery of the cabinet. Once you have located and recorded these numbers, refer to the sample numbers given to the right to identify the components of your cabinet.

SAMPLE OF CABINET LABELING

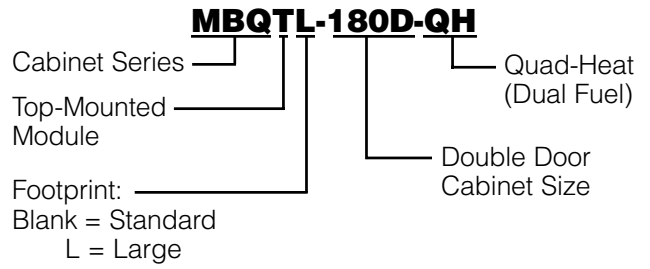

Model Number	_____
Serial Number	_____
Module Serial Number	_____

NOTE: Please read this manual thoroughly before using your cabinet. If you should have questions, please contact Metro customer service department.

B. FEATURES — ALL MODELS

In order to utilize your new cabinet to its full potential; take a minute to identify the following features that have been provided for your convenience.

- The module has been placed at the top of the cabinet for easy accessibility and efficient operation.
- Clearly marked control panel for easy viewing and allowing temperature adjustments without opening the door.
- Handles on each end of the cabinet.
- Optional swing-up handle.
- Thermometer, timer and dual function white board/ clipboard on the door.
- Easy pull magnetic door latch.
- Kick latch on all doors.
- All components — door, module and shelves are removable to permit thorough, obstruction-free cleaning.
- Optional swivel-lock caster system.
- Optional canned fuel system. Includes chimney, baffles and canned fuel drawers. All are removable to permit thorough, obstruction-free cleaning.
- Optional travel latch.

II. OPERATING INSTRUCTIONS

A. ELECTRIC HEATING SYSTEM

Your cabinet is designed to MAINTAIN the temperature of HOT prepared foods. The module is equipped with a thermostatically controlled heater and a blower for air circulation. A POWER switch is provided along with a red light to indicate when the unit is switched ON. Next to the POWER switch is the TEMPERATURE control.

A three-wire grounded lead power cord is supplied fixed to the module. The cord cannot be separated from the module. When the cabinet is not in use, the cord can be either wrapped around the module or looped over the push handles.

1. With the POWER switch OFF, plug the power supply cord into a standard grounded 15 amp, 125VAC receptacle.
2. Snap POWER switch to ON. The red POWER light will now glow and the blower will begin circulating air.
3. Turn the TEMPERATURE thermostat to a setting of 10. The holding unit is now in operation.
4. After allowing the cabinet to PREHEAT FOR APPROXIMATELY 45/60 MINUTES, reduce the thermostat setting to 6/8. In a room of average temperature (72°F) this should provide 150° to 170°F. Adjustments to the temperature may be made as necessary.

THIS IS A HOT FOOD HOLDING CABINET AND IS NOT INTENDED TO RETHERMALIZE COLD FOOD. MAKE SURE FOOD AND CABINETS ARE AT PROPER TEMPERATURES BEFORE PLACING FOOD IN THE CABINET.

NOTE: The POWER (red) light will glow as soon as the POWER switch is switched ON and will continue to glow until switched OFF. The blower will operate as long as the POWER switch is ON.

It is not necessary at the end of the operating day to disrupt the TEMPERATURE setting in order to turn the unit OFF. By switching the POWER switch to OFF, the unit is no longer operating. By switching the POWER switch to ON when resuming operations, the cabinet will attain the preset level (or it can be preheated at a setting of 10 before adjusting to the desired temperature).

B. CANNED FUEL SYSTEM (Optional)

The Canned Fuel system does not require the electric heating module to be turned on for operation. Each bottom-mounted drawer holds 2 cans of fuel. Lift slightly and pull the drawer out until it stops or lift the drawer front and remove it from the cabinet. Place a fuel can into each round cutout and light the fuel. Close the drawer.

NOTE: Filling each canned fuel drawer with 2 cans of fuel will heat the unit to 200°F in approximately 45 minutes. In order to maintain a desired temperature, some of the canned fuel cans may need to be extinguished.

Follow manufacturer's guidelines for canned fuel usage.

C. COUNT-UP/COUNT-DOWN TIMER/CLOCK CLOCK MODE

1. Press the Mode button until the clock icon appears on screen next to the printed "CLOCK" icon.
2. Press and hold (SET) for two seconds.
3. "HOURS" will flash.
4. Press (▲) or (▼) to set.
5. Repeat process to set minutes or seconds.
6. To complete the process press (SET).

NOTE: The two-second delay is to prevent accidental changing of time. There is no delay in Timer mode.

COUNT-DOWN TIMER MODE

Can be used to countdown the minutes until the canned fuel needs to be replenished.

1. Press the Mode button until the timer icon appears on the screen next to the printed "TIMER" icon.
2. Press (SET).
3. "HOURS" will flash.

4. Press (▲) or (▼) to set up or down to desired interval (23:59:59 max.).
5. Repeat process to set minutes or seconds.
6. Press (START) to start. Press (STOP) to stop.

HELPFUL HINTS:

- If you want to set only hours, it is not necessary to press (SET) through minutes and seconds. Simply set desired interval and press (START).
- As a reminder, your timer will “beep” for 3 seconds when it reaches 5 minutes before set interval expires.
- When timer reaches 00:00:00 the alarm will sound and “TIME’S UP!” will appear on the screen. Your timer will now begin to count up. The alarm will stop after 60 seconds and your timer will continue to count up until you press (STOP).
- (CLEAR) button can be used at any time to clear the display. (CLEAR) button also functions for recall of last setting.
- (RECALL) feature: after you press (STOP), pressing the (RECALL) button will automatically display the last timer setting.
- Each time you press (▲) or (▼) the digits will change once. If you hold the button down digits will change rapidly.

COUNT-UP TIMER MODE

Can be used to track how long food has been in the cabinet.

1. Press the Mode button until the stop watch icon appears on screen next to the printed “STOP WATCH” icon.
2. Press (START) to start. Press (STOP) to stop.

III. CLEANING INSTRUCTIONS

CAUTION

AT NO TIME SHOULD THE MODULE OR CABINET BE WASHED OR FLOODED WITH WATER OR LIQUID SOLUTION. NEVER STEAM CLEAN. SEVERE DAMAGE OR ELECTRICAL HAZARD COULD RESULT.

1. Turn off power switch.
2. Unplug the unit from its power source.

WARNING

ALLOW THE UNIT TO COOL BEFORE CLEANING, AS THE INTERIOR OF THE CABINET MAY BE HOT ENOUGH TO BURN.

A. SHELF REMOVAL/INSTALLATION

To remove the shelves, all shelves must first be lowered onto the bottom shelf, lift the uppermost shelf off of the stack so that you are holding onto the long edge of the shelf and the shelf is hanging vertically. Position the shelf so one vertical edge is in one of the rear cabinet corners. Swing the other vertical edge out the

door and remove the shelf. Repeat until all the shelves are removed.

To install the shelves, reverse the above procedure. Before installing shelves, install the Quad-Heat Fuel System baffle(s) and chimney(s) (Section C below).

NOTE: The shelf wires that run from left to right in the cabinet should be on the top side of the installed shelves. Make sure the shelves are seated in the hangers correctly.

B. ELECTRIC HEATING MODULE REMOVAL/INSTALLATION

Due to module location, 2 people are required to remove it from the unit.

Coil power cord and place on module top. No hardware secures the module to the cabinet top. Grasp the front and rear horizontal module handles and lift upward until bottom duct clears cabinet top. Walk the module to one end and lower.

Do not use abrasive cleaners. For every cleaning method, best results are always obtained when the cleaner and technique are matched to the soil conditions involved. Contact your detergent representative to ensure the cleaning product being used is recommended for use on stainless steel. Follow the manufacturer’s directions on cleaners.

Never mix cleaners.

CAUTION

DO NOT ALLOW THE CABINET POWER SUPPLY CORD RECEPTACLE TO COME IN CONTACT WITH WATER OR CLEANSERS. IT MUST BE DRY BEFORE PLUGGING THE MODULE POWER SUPPLY CORD INTO IT.

C. QUAD-HEAT DUAL FUEL SYSTEM REMOVAL/INSTALLATION

1. The heat conductive baffles spread the heat from the canned fuel drawers to the corner chimneys. The heat baffles are next to the standard electric module. First, remove the Electric Heating System module. To remove a baffle, lift up on the recessed handle to disengage the edge of the baffle from the locator pin in the bottom of the cabinet. Then slide the baffle away from the nearest end of the cabinet until it clears the shelf hangers and lift it out of the cabinet.
2. To remove the corner chimneys (after removing the heat conduction baffles) put your thumb and finger into the two holes near the upper end of the chimney and lift the chimney off its hanger and remove it from the cabinet.

To install the Quad-Heat dual fuel system, reverse the above instructions. When installing the chimneys, make sure they are securely seated on the hangers. When sliding the baffles to the end of the cabinet, make sure the slots in the bottom of the

chimney engage the baffle and that the baffle is locked into the locator pins by pushing down on the recessed handle.

D. SPECIFIC CLEANING INSTRUCTIONS

CAUTION

DO NOT IMMERSE THE ELECTRIC HEATING MODULE WHEN CLEANING.

1. Use a damp cloth and dry with a towel. Special attention should be paid to keeping the air-inlet area and the controls area free of dirt build-up.

BE SURE TO THOROUGHLY DRY THE MODULE BEFORE RETURNING IT TO USE.

2. Do not neglect to clean the under-chassis area, especially the area above each caster.
3. The cabinet or component(s) must be thoroughly rinsed to remove any residue that may stain the materials.

E. GENERAL CLEANING INSTRUCTIONS

1. LIGHT SOIL

If routine (daily) cleaning is practiced, a mild soap and warm water should be sufficient to keep the unit clean.

2. HEAVIER SOIL

If cleaning has been postponed, solvent or emulsion type cleaners that can be applied with bare hands will give excellent results. Such cleaners are available under various brand names. Detergent suppliers can recommend materials appropriate for use on stainless steel.

NOTE: For every cleaning method, best results are always obtained when the cleaner and techniques are matched to the soil conditions involved. To ensure using the proper cleaner for stainless steel, contact your detergent representative.

IV. MAINTENANCE

A. CABINET MAINTENANCE

Your cabinet has been designed to require very little maintenance. With normal use, cleaning is the only form of maintenance that needs to be done on a regular basis. Keeping the casters free of dirt build-up will go a long way in prolonging their life.

If your cabinet is rolled over rough surfaces or transported over the road, the various threaded fasteners, i.e., screws and nuts, should be periodically inspected and tightened if necessary, particularly the handles, door hinges and caster fasteners.

B. ELECTRIC HEATING MODULE MAINTENANCE

The module, on the top of your cabinet, has also been designed to require very little maintenance. With normal use, cleaning is the only form of maintenance that needs to be done on a regular basis. When cleaning, do not spray water up into the module and do not immerse the module in water. Wipe with a damp cloth and dry with a towel. Keeping vital areas such as the air-inlet area and the controls area free of dirt build-up will go a long way in prolonging the life of the electrical components. No maintenance is required on the electrical components.

C. BLOWER MOTOR MAINTENANCE

The blower motor requires no maintenance other than keeping the unit clear of dirt, dust and food particles.

V. REPLACEMENT PARTS AND REPLACEMENT LIST

A. CABINET — ALL MODELS

Refer to the Cabinet Replacement Parts List on page 7 to identify the replacement parts.

Cabinet Replacement Parts Diagram

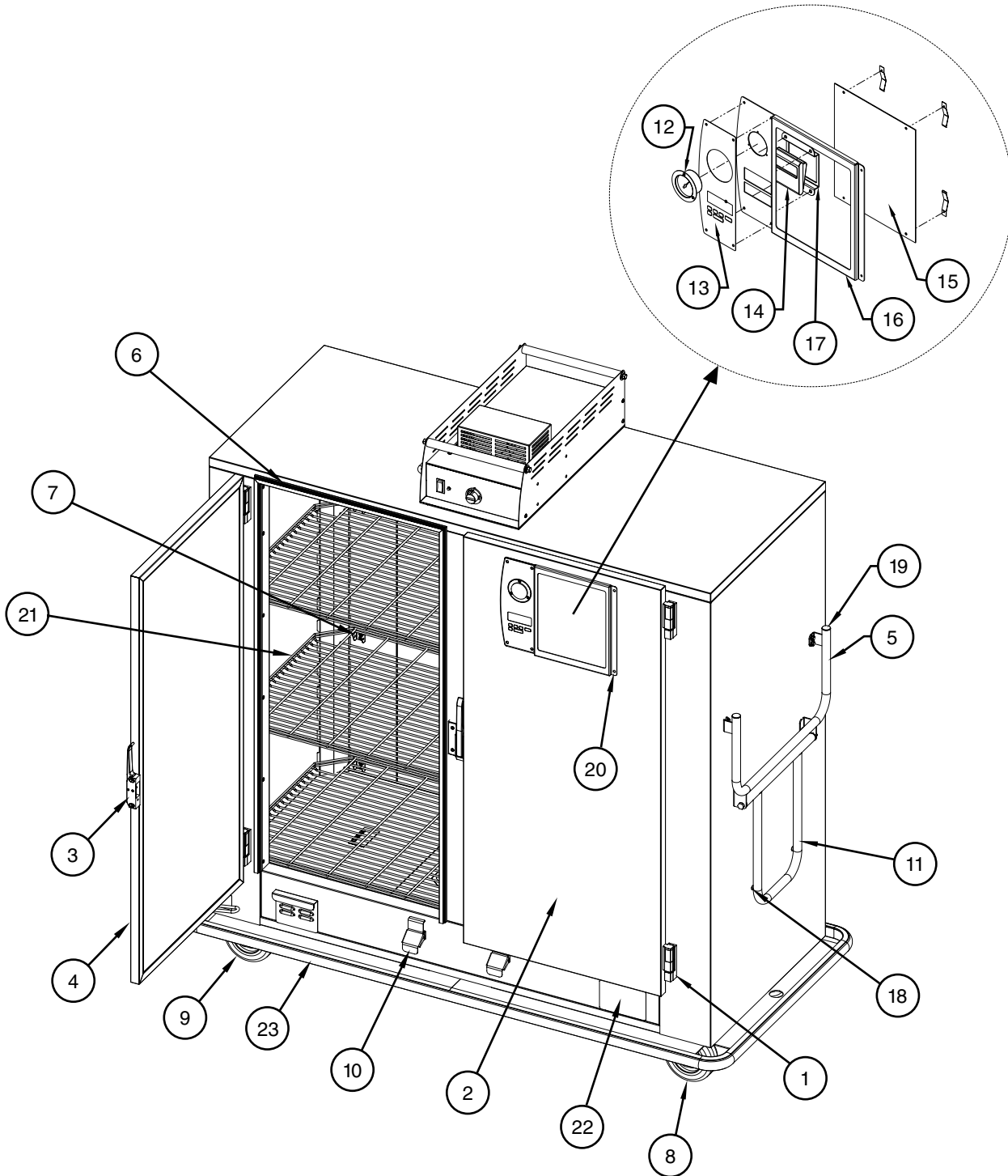

CABINET REPLACEMENT PARTS LIST

Item No.	Part No.	Description
1	RPC14-119	HINGE
2	RPSEFS-200RDOR RPSEFS-180RDOR RPSEFS-150RDOR RPSEFS-120RDOR	RIGHT DOOR, MBQL-200D, MBQLT-200D, MBQT-200D RIGHT DOOR, MBQL-180D, MBQLT-180D, MBQT-180D RIGHT DOOR, MBQL-150D, MBQLT-120D, MBQT-150D RIGHT DOOR, MBQL-120D, MBQLT-120D, MBQT-120D
3	RPC14-118	LATCH
4	RPSEFS-200LDOR RPSEFS-180LDOR RPSEFS-150LDOR RPSEFS-120LDOR	LEFT DOOR, MBQL-200D, MBQLT-200D, MBQT-200D LEFT DOOR, MBQL-180D, MBQLT-180D, MBQT-180D LEFT DOOR, MBQL-150D, MBQLT-150D, MBQT-150D LEFT DOOR, MBQL-120D, MBQLT-120D, MBQT-120D
5	RPC11-446	HANDLE
6	RPC06-856	GASKET
7	RPSHELF-HANG	SHELF SUPPORT KIT (INCLUDES HARDWARE)
8	RP6-SWIVEL RP8-SWIVEL RP8-AIRSWIVEL	6" SWIVEL/BRAKE CASTER KIT 8" SWIVEL/BRAKE CASTER KIT 8" SWIVEL AIR CASTER KIT
9	RP6-RIGID RP8-RIGID RP8-AIRRIGID	6" RIGID CASTER KIT 8" RIGID CASTER KIT 8" RIGID AIR CASTER KIT
10	RPKICK-LATCH	KICK LATCH KIT
11	RPC11-447	SWING UP HANDLE
12	RPC13-189	THERMOMETER KIT
13	RPC05-905	OVERLAY, BEZEL
14	RPC13-194	TIMER
15	RP-WHITEBRD	WHITE BOARD
16	RP-BEZELPNL	BEZEL PANEL
17	RP-TMRBRKT	TIMER BRACKET
18	RPC06-201	BUMPER, SWING HANDLE
19	RPC06-035	CAP, HANDLE
20	RP-BEZELBUMP	BEZEL BUMPER KIT
21	RPDD-SHELF RPLX-SHELF	SHELF, MBQT, UNITS SHELF, MBQLT UNITS
22	RPCF-DDCOV	CANNED FUEL OPENING COVER
23	RPC06-957-204 RPC06-957-216	BUMPER STRIP X 204", MBQT BUMPER STRIP X 216", MBQLT

B. ELECTRIC HEATING MODULE

CAUTION

DO NOT ATTEMPT TO SERVICE THE MODULE UNLESS YOU ARE QUALIFIED AND KNOWLEDGEABLE OF ELECTRICAL REPAIRS AND ELECTRICAL SAFETY.

Your module has been designed to be user-serviceable, assuming a basic knowledge of the operation of electrical devices. This section has been written to guide the user step by step, and in layman's terms, through the dismantling and servicing of the module. Before attempting to service your module, read the appropriate Module Repair Procedures (found elsewhere in this section) thoroughly. If you do not understand the Repair Procedures or prefer not to service your module yourself, or if your warranty is still in effect, please contact our Customer Service Department for the factory authorized service agency nearest you. See back cover for contact information.

DANGER

ELECTRICAL SHOCK HAZARD. DISCONNECT POWER BEFORE SERVICING OR CLEANING.

CAUTION

IT IS IMPORTANT THAT ALL SAFETY PRECAUTIONS PERTAINING TO THE SERVICING OF ELECTRICAL DEVICES BE OBSERVED AT ALL TIMES.

1. Dismantle your Electric Heating System module for servicing per the following instructions.

NOTE: To replace the Thermostat Knob it is not necessary to dismantle the module.

- a. Make sure the power supply cord is not plugged into an outlet. Be certain that the module has cooled to a temperature safe for handling.
- b. Due the module location, 2 people are required to remove it from the unit. Coil power cord and place on module top. No hardware secures the module to the cabinet top. Grasp the front and rear horizontal module handles and lift upward until bottom duct clears cabinet top.

Walk the module to one end and lower.

- c. Place the module on a dry, non-flammable work surface.

CAUTION

IF NECESSARY TO RECONNECT POWER WHILE SERVICING, PRACTICE EXTREME CAUTION SO AS NOT TO RECEIVE AN ELECTRICAL SHOCK FROM EXPOSED COMPONENTS.

- d. To replace the thermostat, switch or indicator light, remove the screws that hold the control panel to the main body of the module to gain access to the part needing replacement. See diagram on page 9.
- e. To replace the blower or heating element, remove the (4) screws securing the blower cover the module cover. Then, remove the (8) screws holding module cover to the module chassis. Lift module cover off unit. Separate insulation, remove screws from the air duct cover and lift off air duct.

NOTE: Retain all hardware for reassembly.

2. **Refer to the Module Replacement Parts Diagram to identify the internal components.** Determine malfunctioning component(s) by electrical diagnostic procedures.
3. After servicing, be sure to verify the routing of each wire with the wiring schematic on page 13 before installing electrical cover and connecting module to power source. **Be sure that the thermostat sensor tube does not contact any electrical connections.**
4. Assemble components using the retained hardware, making sure that no wires are pinched between the cover and the component chassis.
5. Install the module on top of the cabinet. For installation procedure, reverse directions in step 1B above.

C. BATTERY REPLACEMENT Count-up/Count-down Timer/Clock

1. To replace the batteries remove the (6) screws holding the bezel panel in place. See item 16 page 6.
2. Pull the panel away from the door to gain access to the back of the timer. See item 14 page 6.
3. Remove the battery door from the timer back and replace with (1) AA 1.5V battery and install by matching the battery polarity with the polarity noted in the battery compartment.

D. SWIVEL-LOCK CASTER SYSTEM OPERATION

The casters that are controlled by the swivel-lock mechanism are normally locked in the rigid or "travel" position. Stepping on the red loop allows the casters at that end of the cabinet to rotate out of the rigid position when the cabinet is moved in tight spaces or around sharp corners, without dragging.

NOTE: You must Press down on the red loop until the casters are out of the rigid position.

When you remove your foot from the red loop the casters will continue to be free to swivel until the cabinet is pulled for a distance from the opposite side and the casters swivel back into the rigid or "travel" position.

Top-Mounted Heating Module — TBQ1700

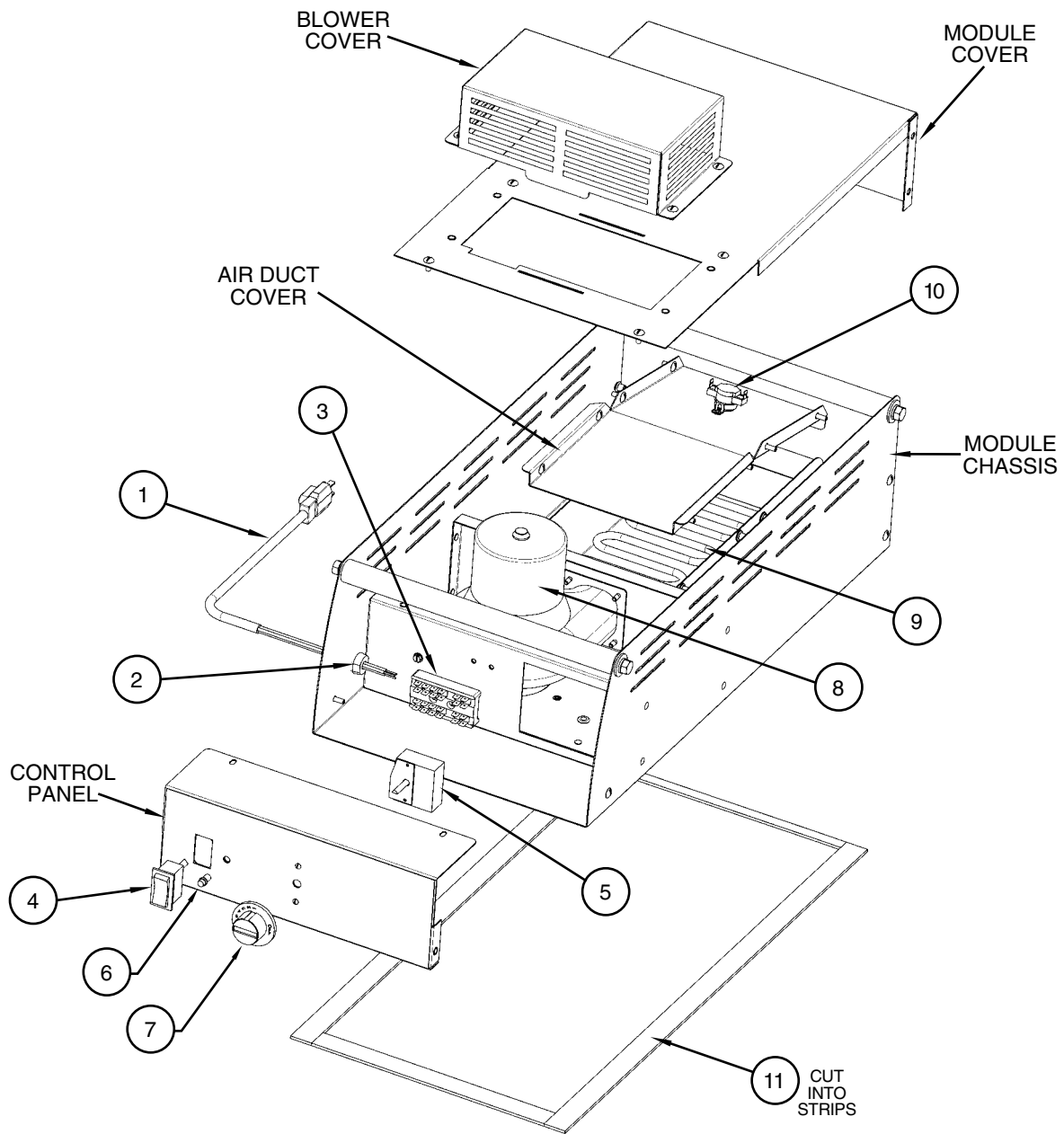

REPLACEMENT PARTS LIST

Item No.	Part No.	Description
1	RPC13-108	POWER CORD
2	RPC13-111	STRAIN RELIEF
3	RPC13-096	TERMINAL BLOCK
4	RPC13-127	POWER SWITCH
5	RPC13-129	THERMOSTAT
6	RPC13-064	RED INDICATOR LIGHT
7	RPC06-313	CONTROL KNOB
8	RPHM20-2103	BLOWER
9	RPC13-166	HEATING ELEMENT
10	RPC13-198	THERMAL CUT OUT
11	RPC06-445-75	GASKET STRIP X 75" LG.

**E. SWIVEL-LOCK CASTER SYSTEM
REPLACEMENT PARTS DIAGRAM**

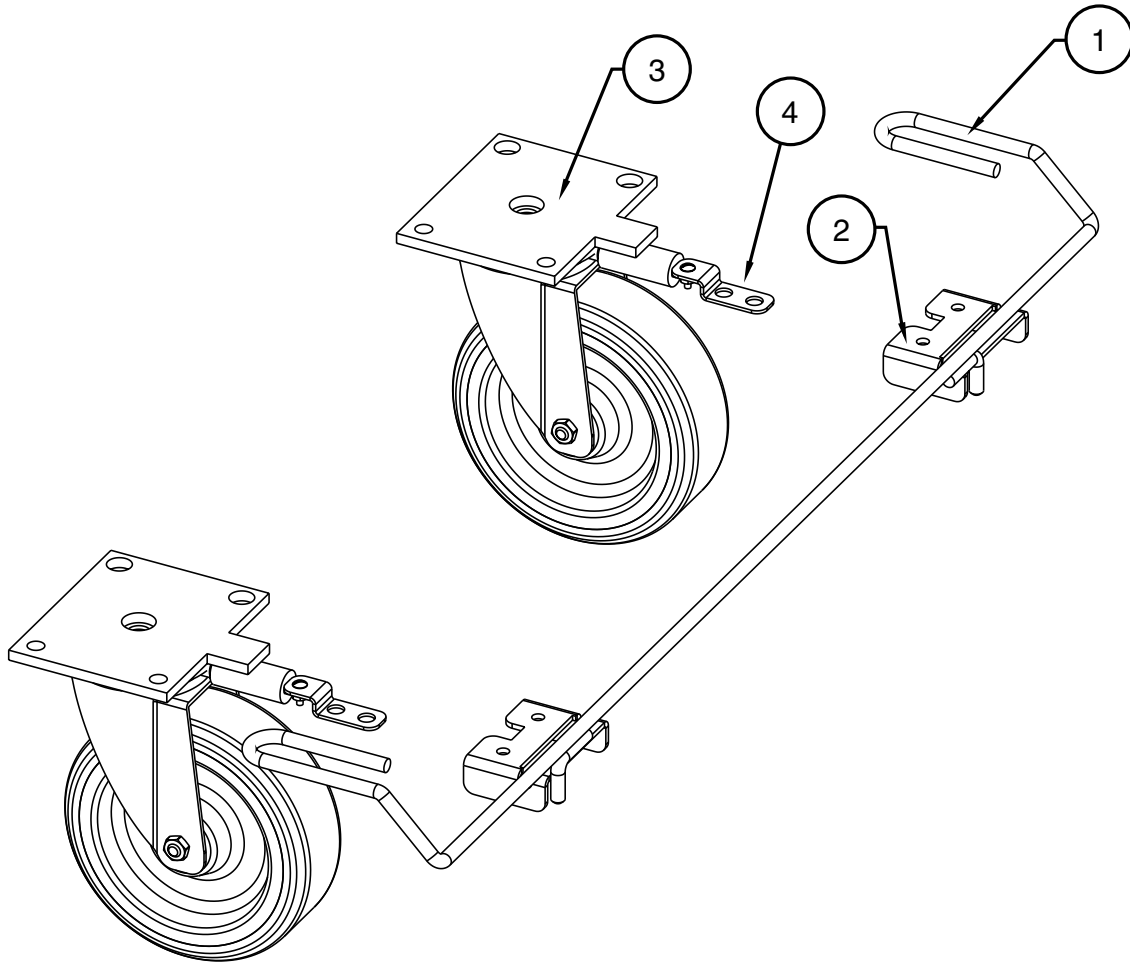

REPLACEMENT PARTS LIST

Item No.	Part No.	Description
1	RPSL-DDWELD RPSL-LXWELD	DOUBLE DOOR CABINET SWIVEL-LOCK RELEASE SINGLE DOOR CABINET SWIVEL-LOCK RELEASE (MBQT, MBQLT)
2	RPSL-RETAIN	RELEASE RETAINER BRACKET
3	RPSL6-CASTER RPSL8-CASTER	6" SWIVEL-LOCK CASTER 8" SWIVEL-LOCK CASTER
4	RPSL-LOCKTAB	(2) SWIVEL-LOCK TABS AND HARDWARE

F. QUAD-HEAT REPLACEMENT PARTS DIAGRAM

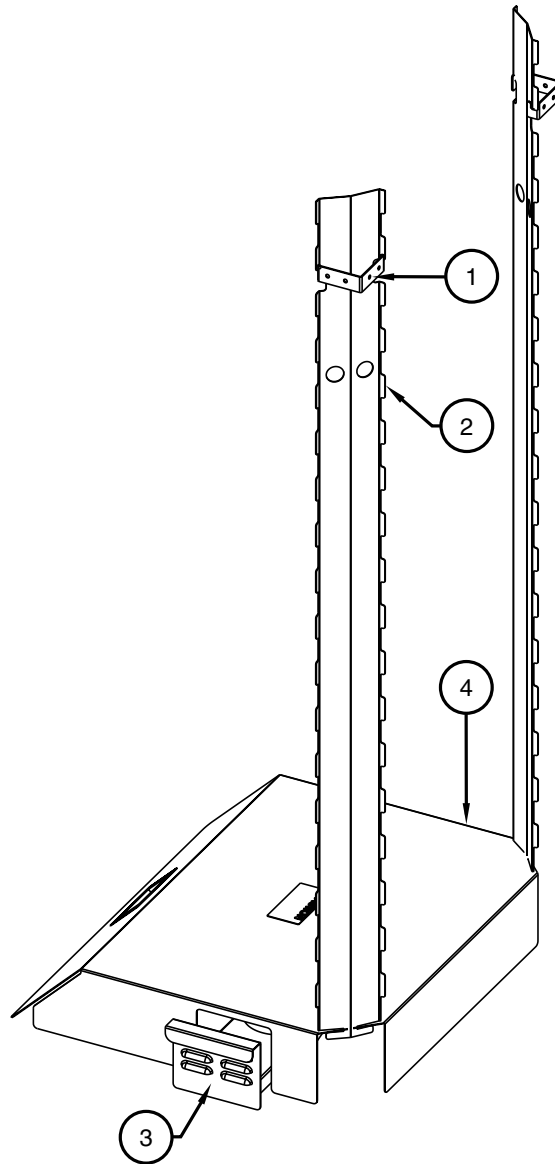

REPLACEMENT PARTS LIST

CABINET MODEL

Item No.	Description	MBQLT-200D-QH	MBQLT-180D-QH	MBQLT-150D-QH	MBQLT-120D-QH
1	CHIMNEY HANGER	RPQH-HANG	RPQH-HANG	RPQH-HANG	RPQH-HANG
2	CHIMNEY	RPQH-200CHIM	RPQH-200CHIM	RPQH-200CHIM	RPQH-200CHIM
3	CANNED FUEL DRAWER	RPQH-DRAWER	RPQH-DRAWER	RPQH-DRAWER	RPQH-DRAWER
4	FLUE	RPQH-XLFLUE	RPQH-XLFLUE	RPQH-XLFLUE	RPQH-XLDFLUE

CABINET MODEL

Item No.	Description	MBQLT-200D-QH	MBQLT-180-QH	MBQLT-150-QH	MBQLT-120-QH
1	CHIMNEY HANGER	RPQH-HANG	RPQH-HANG	RPQH-HANG	RPQH-HANG
2	CHIMNEY	RPQH-200CHIM	RPQH-200CHIM	RPQH-200CHIM	RPQH-200CHIM
3	CANNED FUEL DRAWER	RPQH-DRAWER	RPQH-DRAWER	RPQH-DRAWER	RPQH-DRAWER
4	FLUE	RPQH-DDFLUE	RPQH-DDFLUE	RPQH-DDFLUE	RPQH-DDFLUE

VI. WIRING SCHEMATICS

TBQ1700 MODULE WIRING DIAGRAM

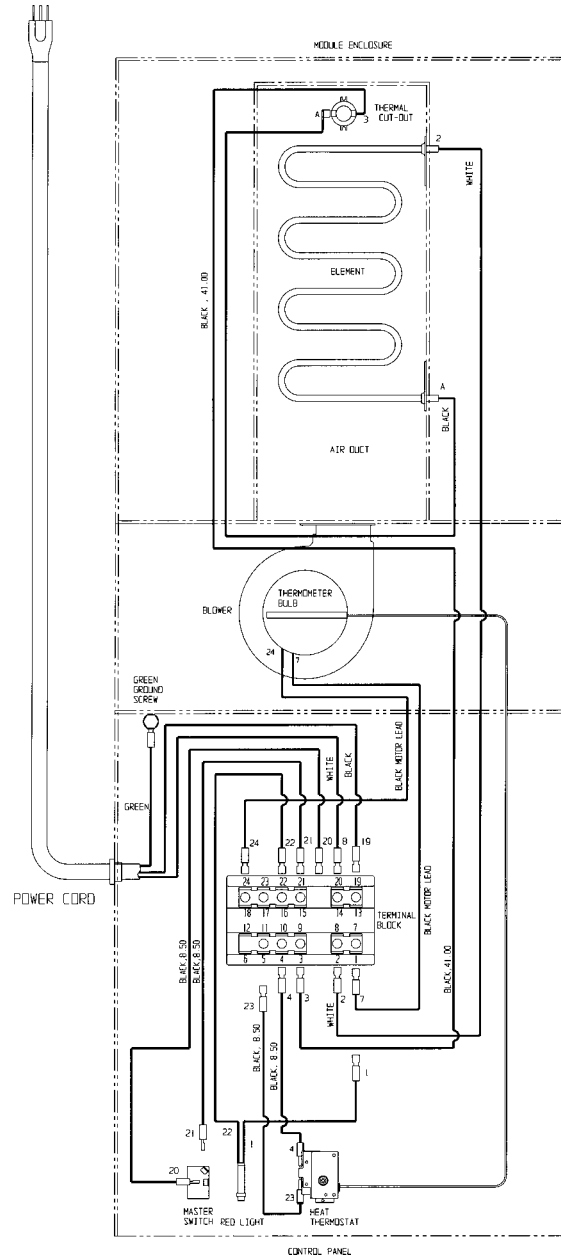

Warranty

WARRANTY, EXCLUSION OF WARRANTIES AND LIMITATION OF LIABILITY.

InterMetro Industries Corporation (hereinafter referred to as "Seller") warrants to the original purchaser that all products in its catalog, or custom products, delivered hereunder will be free from defects in workmanship and material. THE FOREGOING WARRANTY IS EXCLUSIVE AND IN LIEU OF ALL OTHER WARRANTIES, EXPRESS, IMPLIED OR STATUTORY, INCLUDING ANY WARRANTY OF MERCHANTABILITY OR FITNESS FOR A PARTICULAR PURPOSE. This Warranty shall be for a period of one (1) year from the date of shipment from Seller's warehouse or factory. If any product delivered hereunder does not meet the Warranty specified above, providing the product has not been altered in any way by anyone other than Seller's factory-authorized representative, and assuming normal and proper use and maintenance, Seller will, at its option, repair or replace any part or material it determines, upon inspection, to be defective; provided however, that a charge for labor will be made except during a period of one (1) year from the date of original shipment from Seller's warehouse or factory. No product, or part thereof, is to be returned to Seller without prior written approval from Seller's factory. All exchanges and replacement shipments will be F.O.B. Seller's factory. Warranties for equipment or articles not manufactured by the Seller are solely the warranties of the manufacturers thereof and they are hereby assigned to the purchaser without recourse to the Seller.

SELLER'S LIABILITY FOR ANY CLAIM OF ANY KIND, WHETHER BASED ON CONTRACT, NEGLIGENCE OR STRICT LIABILITY IN TORT, AND BY WHOMEVER MADE, FOR ANY DIRECT, INDIRECT, INCIDENTAL OR CONSEQUENTIAL LOSS, DAMAGE OR INJURY, RESULTING TO THE PURCHASER OR ANY THIRD PARTIES, arising out of, connected with or resulting from this Agreement, or from the performance or breach thereof, or from the manufacture, sale, delivery, resale, installation, inspection, repair or use of any product covered by or furnished under this Agreement, WHETHER OR NOT CAUSED BY SELLER'S NEGLIGENCE, SHALL IN ALL EVENTS BE EXCLUSIVELY LIMITED TO THE COST OF CORRECTING DEFECTIVE, DAMAGED OR NON-CONFORMING PARTS OR MATERIAL AS HEREIN PROVIDED, and upon the expiration of one (1) year, all such liability shall terminate.

SELLER DOES NOT AUTHORIZE any person to assume for it any obligations or liabilities greater than or different than those set forth in this Warranty. The terms under which any of Seller's products may be resold must be limited in accordance with this Warranty.

THIS AGREEMENT, and all the rights and obligations arising hereunder, shall be construed in accordance with, and be governed by, the law of the Commonwealth of Pennsylvania, U.S.A.

TO INSURE WARRANTY implementation, return the completed registration card within 15 days of cabinets' receipt to: InterMetro Industries Corp., Wilkes-Barre, PA 18705



InterMetro Industries Corporation
Wilkes-Barre, PA 18705

3/03

Thank you for purchasing a Metro Heated Banquet Cabinet. We are certain you will be more than satisfied with its quality and performance. Please fill in the warranty information space below so we may register your warranty. Also, so that we may learn more about our customers and hopefully be of continued service in the future, please take a moment to fill in the customer information space below.

Thank You

CUT ALONG DOTTED LINE

CUSTOMER INFORMATION

1. Which one of the following best describes your establishment?

- a. Full-Service Restaurant
- b. Banquet Hall
- c. Hotel/Motel
- d. Hospital/Nursing Home
- e. College/University
- f. School
- g. Employee Feeding
- h. Other _____

WARRANTY INFORMATION:

Cabinet Model No. _____
 Module Serial No. _____
 Date Purchased _____
 Customer Name _____
 Address _____

 Phone No. _____

For warranty coverage, this card must be returned to Metro.

FOLD HERE — DO NOT DETACH

CUT ALONG DOTTED LINE

2. Please indicate the two product benefits that were of major interest to you.

- a. 3-point handle control.
 - b. Swivel-lock caster system maneuverability.
 - c. Quad-Heat Canned Fuel System performance.
 - d. Easy-to-clean, removable heating module.
 - e. Hands-free access kick-latch.
 - f. Control panel information (timer/white-board).
 - g. Reliable design and construction.
 - h. Flexibility provided by mini-rack accessory.
 - i. Other _____
- _____
- _____

3. Main factor that led to your decision to purchase this product?

- a. Product operating and functional features
- b. Overall quality
- c. Price
- d. Availability
- e. Other _____

4. Three sources that led to the purchase of his product — in the order of their impact (1 — being most impact; 3 — being least impact).

- a. Trade Journal Ad
- b. Trade Show
- c. Sales Call
- d. Direct Mail
- e. Previous Purchase
- f. Other _____



WILKES-BARRE PA 18705-9968

P O BOX A

ATTN: CUSTOMER SERVICE

INTERMETRO INDUSTRIES CORPORATION

POSTAGE WILL BE PAID BY

BUSINESS REPLY MAIL
FIRST-CLASS PERMIT NO. 121 WILKES-BARRE, PA

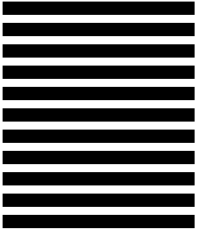

NO POSTAGE
NECESSARY
IF MAILED
IN THE
UNITED STATES

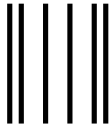

FOLD HERE — DO NOT DETACH

STAPLE HERE

STAPLE HERE

STAPLE HERE



InterMetro Industries Corporation

North Washington Street, Wilkes-Barre, PA 18705

For Product Information Call: 1-800-433-2232

Visit Our Web Site: www.metro.com

L01-417
8/05

Information and specifications are subject to change
without notice. Please confirm at time of order.