

Mealstream 500 Series

Project _____
 Item _____
 Quantity _____
 CSI Section 11400 _____
 Approval _____
 Date _____

Mealstream 500 Series

Models

EC501

EC502

EC503



Standard Features

- 2/3 Gastronorm cavity for large multi-portion dishes.
- Middle shelf provides maximum flexibility.
- Microwave combination mode reduces cooking times by up to 5 times.
- Easy to clean digital touch pad control.
- Fully programmable (up to 10 programs) including multi-stage

Options & Accessories

- Rack
- Vitreous enamel tray x2
- MenuKey™

Specifications

The Mealstream 500 series Oven is the undisputed market leader for electric microwave combination cooking.

Ideal for caterers who need the extra capacity to prime cook several items at the same time or to regenerate large multi-portion dishes.

The Merrychef MenuKey allows the user to download new programmes. A change of menu could be implemented simultaneously in remote sites using this feature.

- Programming (up to 3 stages per program).
- User friendly operation.
- Quick pre-heat time (max 15 min).
- Low loss insulated cavity for energy efficiency.
- In-built diagnostics to avoid unnecessary service calls.
- 4 microwave power levels allow the most delicate products to be cooked (e.g. frozen baguettes).
- Quality assured BS EN ISO 9001 accreditation.



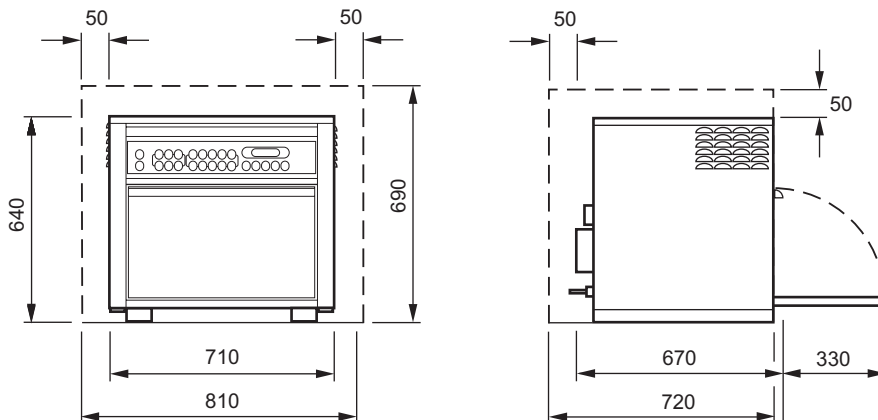

Allow a minimum of 50mm clearance to sides and rear to allow air to circulate freely

DIMENSIONS

| MODEL NO. | OVERALL SIZE mm | | | WEIGHT |
|---------------|-----------------|-------|-------|-------------------------|
| | HEIGHT | WIDTH | DEPTH | |
| 501,502 & 503 | 640mm | 710mm | 670mm | 90kg Nett 95kg Gross |

Capacity 48.86 litres
Internal Dimensions mm (HxWxD) 260 x 490 x 360

POWER REQUIREMENTS

Power input 6.2kW maximum

| ELECTRICAL SUPPLY | | | | |
|-------------------|---------------|--------------|------------------|----------------|
| Country | Voltage | Arrangement | Connections Used | Current /Phase |
| UK | 230-240V 50Hz | Single Phase | 1P N & E | 32 Amp |
| UK | 400-415V 50Hz | Dual Phase | 2P N & E | 16 Amp |
| EU | 380-400V 50Hz | Dual Phase | 2P N & E | 16Amp |

For Oven models suitable for a 60Hz supply, please contact the sales office.

POWER OUTPUT

Microwave Output 1425 Watts (IEC705) @ 100%
Convected heat 3000 Watts
Combination Mode 1425 Watts microwave + 3000Watts
Power Levels 100%, 75%, 50%, 25% & Convection only

CONVECTED HEAT

3000 Watts Heating Element.
Temperature settings from OFF, 150°C to 250°C in 25° C steps.
Safety System Agency approved monitored interlock door system.

CONSTRUCTION

Cavity: 304 Stainless Steel
Casework: 430 Stainless Steel

STANDARD ACCESSORIES

Rack
Vitreous Enamel Tray x2

TECHNICAL SPECIFICATIONS

| | |
|------------------------|--|
| Magnetrons | Two |
| Safety interlocks | Three |
| Distribution system | Rotary Antenna |
| Timer | Up to 29minutes 59seconds Up to 3x 29min 59secs with multi-stage programs |
| Timer controls | Digital touch pad control |
| User interface | Built-in diagnostic messages Digital LED display of cooking time Easy-to-use pre-programmed operation, 10 programs Numerical display of actual cavity temperature |
| Additional Information | High speed convection fan |

INSTALLATION INFORMATION

Away from major heat sources.
Place on a flat surface that is level, strong and stable.
Do not stack the oven directly on top of another.
Use a separate shelf or double tiered stand.
Allow sufficient clearance in front of the oven for the door to open fully (330mm) and the filters to be removed for cleaning (560mm).
If circuit breakers are in use, ensure Type C units are fitted.

For further information on Merrychef products and services or advice on which machine suits you best please contact the Sales Office.

For models for the USA please contact the Sales Office.



Station Road West,
Ash Vale, Aldershot
Hampshire GU12 5XA
United Kingdom

Tel: +44 (0)1252 371000
Fax: +44(0)1252 371007
E-mail: info@merrychef.com

www.merrychef.com
Datasheet Part No.
32Z3378 Issue 4
Printed in the UK ©Merrychef Ltd.

Enodis®