

DHB2PT-32 Dedicated Holding Bin



DHB2PT-32 Dedicated Holding Bin

SANITATION



CLASSIFIED 59GM
AS TO NSF4-1996



Prince Castle Dedicated Holding Bins are ideal for almost any operation, especially those preparing and holding food prior to serving. Using patented Reli-A-Temp heating technology, Prince Castle DHBs keep exterior bin surfaces cool while food is held at proper serving temperatures and moisture levels. Users of Prince Castle DHBs have realized many benefits, including better food quality, longer holding times, reduced food waste and greater equipment reliability.

Each cavity's temperature is digitally-controlled by Prince Castle's time-tested technology, ensuring that food is always being held at desired temperatures, making HACCP and ServSafe programs easier to implement.

The DHB2PT-32 is ideal for holding fried foods and/or pre-packaged menu items separately or together.

Featuring a pass-thru design, allowing access from back and front of the bin, and a small footprint, the DHB2PT-32's model flexibility makes it a great choice for any operation.

STANDARD FEATURES

- Compact design allows bin to fit anywhere.
- Pass-thru design for access from front and back.
- Ideal for holding fried foods and/or pre-packaged menu items separately or together.
- Each cavity easily accommodates two 1/2-size sheet pans.
- Exclusive Reli-A-Temp™ infrared heaters provide consistent temperature for an ideal holding environment.
- Independent upper and lower heating system per cavity.
- Adjustable temperature from 150°F - 275°F.
- Solid state digital controls.
- On/Off main power switch.
- Stainless steel and aluminum construction.
- One-year parts and labor warranty.

CAPACITY

- Six 1/3-size pans
- Four 1/2-size pans

DHB2PT-32
Dedicated Holding Bin

SPECIFICATIONS

DIMENSIONS

MODEL NO.	WIDTH IN. (CM)	DEPTH IN. (CM)	HEIGHT IN. (CM)	SHIP WT LB. (KG.)	NUMBER OF INDEPENDENTLY CONTROLLED HEATERS	CAPACITY - NUMBER OF 1/2-SIZE PANS
DHB2PT-32	32.27" (82)	19.94" (50.7)	13.62" (34.6)	90 (41)	4	4

ELECTRICAL

MODEL NO.	VOLTS	Hz.	WATTS	AMPS	PLUG NUMBER	AGENCY APPROVAL
DHB2PT-32	208	60	2500	12.0	L6-15P	UL SAN., UL, cUL
DHB2PT-32CE	220-240	50	2950	12.3	CEE 7-7	UL SAN., CE, GS
DHB2PT-32GB	240	50	2950	12.3	BS 1363A	UL SAN., CE, GS

CAPACITY

Six 1/3-size pans
Four 1/2-size pans

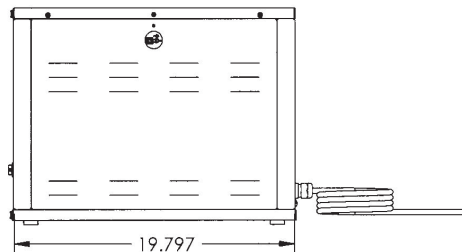
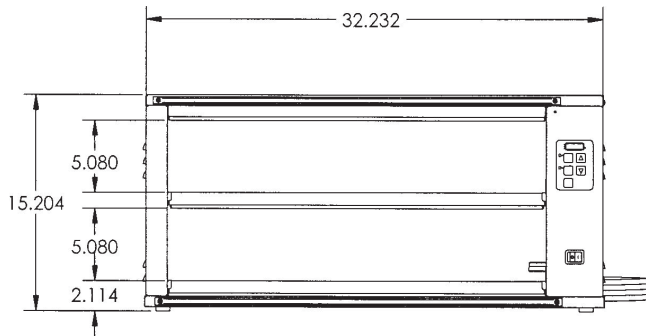
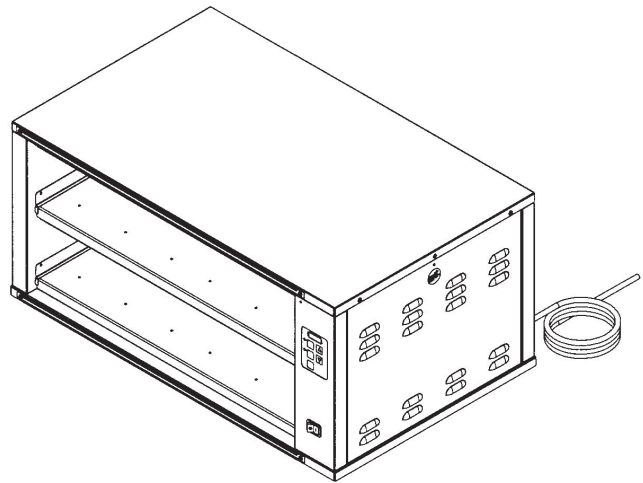

DEDICATED HOLDING BINS

DHB2PT-32

*Designs and specifications are subject to change without notice.