

SINGLE DOOR COOLER SERIES

Perlick Features

- Front vented compressor.
- Self-closing field reversible door.
- Quiet-running high efficiency compressor.
- Two inch foamed-in-place walls provide greater energy efficiency and structural strength.
- Efficient, balanced refrigeration system.
- Heavy-duty high density polyethylene door sill.
- Reinforced base will not bend or sag.
- Interior floor drain exits right or bottom.
- Incandescent front light.
- Vinyl coated shelves.
- Heavy-duty reversible stainless steel hinges.
- Door options:
 - Solid black vinyl coated or stainless.
 - Glass w/ black vinyl coated or stainless frame.

MODEL NOS.

- CS32SB
- CS32SG
- CS32SS
- CS32ST

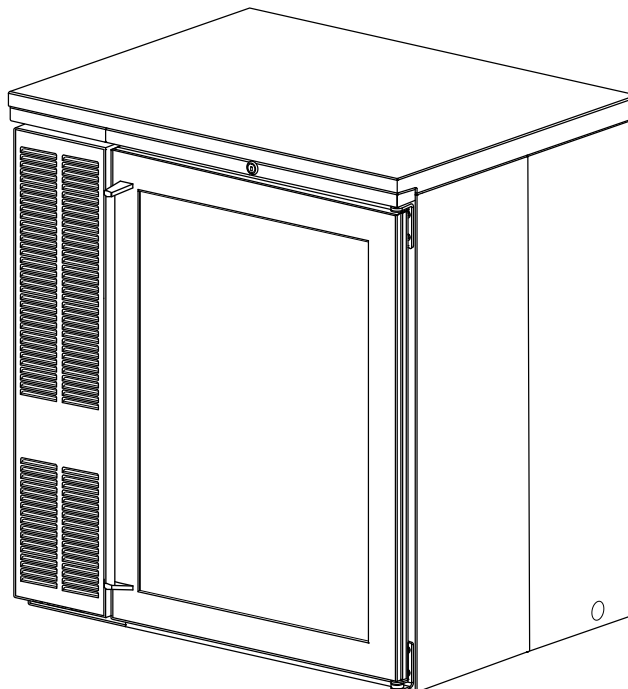

8300 West Good Hope Road • Milwaukee, WI 53223 • Phone 414-353-7060 • Fax 414-353-7069
Toll Free 800-558-5592 • E-Mail: Perlick@Perlick.com • www.Perlick.com

Sizes and Specifications Single Door Cooler Series

Job _____
 Area _____
 Item No. _____
 Model No. _____

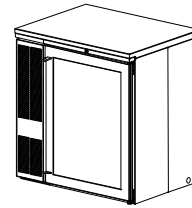

MODEL NOS.		CS32SB	CS32SG	CS32SS	CS32ST
DOOR FINISH		Black Coated Solid	Glass w/ Black Coated Frame	Stainless Steel Solid	Glass w/ Stainless Steel Frame
CABINET DIMENSIONS	Length - Inches (mm)	32" (813)	32" (813)	32" (813)	32" (813)
	Depth - Inches (mm)	24 ³ / ₄ " (629)	24 ³ / ₄ " (629)	24 ³ / ₄ " (629)	24 ³ / ₄ " (629)
	Height - Inches (mm)	34 ³ / ₄ " (876)	34 ³ / ₄ " (876)	34 ³ / ₄ " (876)	34 ³ / ₄ " (876)
NUMBER OF SHELVES		3	3	3	3
CASE CAPACITY (based on 12oz Long Neck bottle)					6
CONDENSING UNIT H.P.					1/6
AMPS					2.7
SHIP WT. Lbs. (kg.)		210 (96)	210 (96)	210 (96)	210 (96)
INTERIOR	Door Pan & Ceiling: High strength polystyrene. Door Sill: High strength polyethylene. Floor Pan: Stainless steel. Walls: Galvanized steel. Includes pilasters, three vinyl coated shelves and light.				
EXTERIOR	Stainless steel top, back, sides and front. Galvanized bottom. Condensing unit grille stainless steel or black vinyl coated to match door finish. Full length stainless steel handle and lock. Right hinged door standard from factory. Door hinging is field reversible.				
DOOR HINGING	Stainless steel hinges with standard locations as illustrated. Field reversible.				
DOOR HARDWARE	Door handles: Full length stainless steel handle. Lock finish: chrome				
REFRIGERATION	R-134a capillary tube-type. Aluminum fin and copper tube evaporator coil. Adjustable temperature control. Self-defrosting.				
VENTILATION	Front ventilated.				
ELECTRICAL	115 Volt, 60 Hz., 1 Phase AC. Furnished with three-prong, six foot NEMA 5-15P cord. Contact Perlick-Milwaukee for other voltage/frequency requirements.				
PLUMBING	Evaporator condensate is removed automatically. Optional floor drain with 3/4" NPT at right end or 1" NPS out bottom come plugged from factory.				
INSULATION	Foamed-in-place polyurethane, 2" walls, 1 1/2" top.				
OPTIONAL ACCESSORIES	<ul style="list-style-type: none"> • Leg set • Caster Sets • Leg & Front Base Plate 				

NOTE: This equipment is intended for the storage and display of non-potentially-hazardous bottled or canned products only.

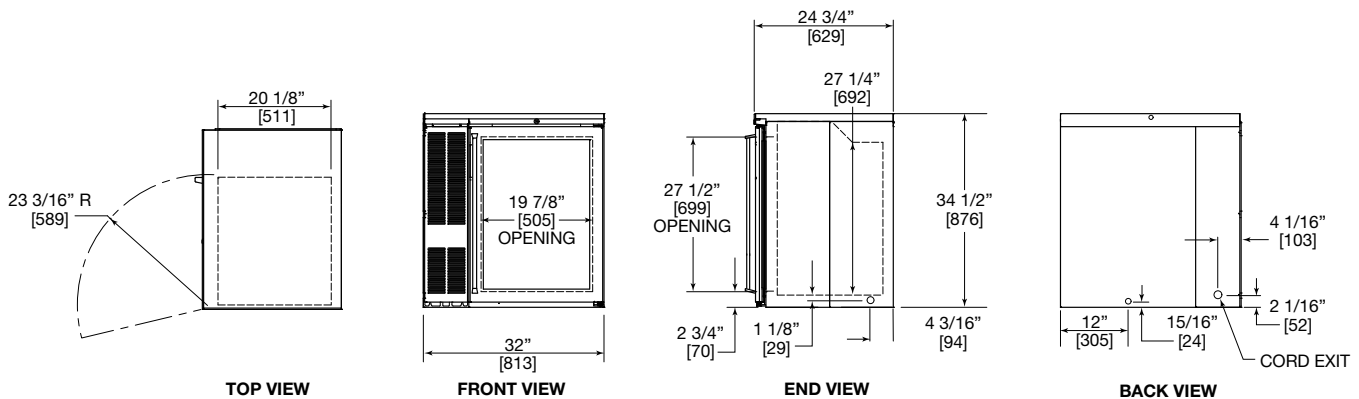

8300 West Good Hope Road • Milwaukee, WI 53223 • Phone 414-353-7060 • Fax 414-353-7069
 Toll Free 800-558-5592 • E-Mail: Perlick@Perlick.com • www.Perlick.com

Perlick is committed to continuous improvement.
 Therefore, we reserve the right to change specifications without prior notice.

Form No. 063005
 Rev. 05.24.10