



MODEL GDF28 Fry Dispenser

EQUIPMENT MANUAL
English (Rev. F)
P/N 291635

Manufactured by
Automated Equipment, LLC
5140 Moundview Drive
Red Wing, MN 55066 U.S.A.
PHONE: 1 (651) 385-2273
FAX: 1 (651) 385-2166
SERVICE FAX: 1 (651) 385-2172
FOR SERVICE in the U.S.A./CANADA, CALL:
1 (800) 248-2724

[http:// www.autoequipllc.com](http://www.autoequipllc.com)

Business Hours: 8:00 AM – 5:00 PM CST
After hours, your call will be handled by a pager service;
a Technical Support Representative will return your call.

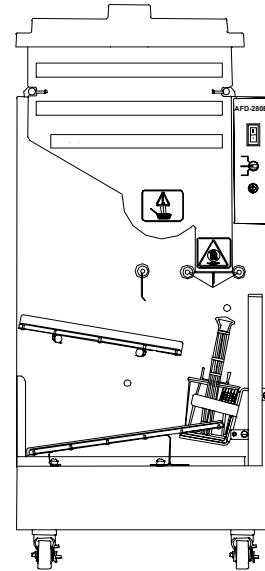

TABLE OF CONTENTS

| | |
|---|----|
| INTRODUCTION | 3 |
| SPECIFICATIONS | 3 |
| FCC STATEMENT | 3 |
| WARRANTY | 4 |
| REQUESTING SERVICE, ASSISTANCE, OR PARTS | 5 |
| SAFETY | 6 |
| ASSEMBLING THE DISPENSER | 7 |
| DAILY SET-UP | 8 |
| DAILY CLOSING | 8 |
| OPERATOR CONTROLS | 9 |
| SEQUENCE OF OPERATION | 11 |
| CONTROLLER FUNCTIONS | 13 |
| ERROR CODES | 16 |
| TROUBLESHOOTING | 25 |
| ADJUSTMENTS AND DIAGNOSTICS | 27 |
| CONTROLLER BOARD LAYOUT | 29 |
| GDF28 SCHEMATIC | 31 |
| PART IDENTIFICATION | 33 |
| BASKET LIFT ASSEMBLY | 36 |
| NEW BASKET LIFT ASSEMBLY | 37 |
| STOPGATE DRIVE ASSEMBLY | 38 |
| ACCUMULATOR ASSEMBLY | 39 |
| DRUM MOTOR ASSEMBLY | 41 |
| LIFT SADDLE ASSEMBLY | 41 |
| NON-CONTACT WEIGHING SYSTEM ASSEMBLY (NCWS) | 42 |

GDF28 Dispenser

The information in this manual is subject to change without notice.

IN NO EVENT WILL AUTOMATED EQUIPMENT LLC BE LIABLE FOR TECHNICAL OR EDITORIAL OMISSIONS MADE HEREIN; NOR FOR DIRECT, SPECIAL, INCIDENTAL, OR CONSEQUENTIAL DAMAGES RESULTING FROM THE FURNISHING, PERFORMANCE, OR USE OF THIS MATERIAL.

This manual is copyrighted with all rights reserved. Under the copyright laws, this manual may not be copied, in whole or part, without the written consent of Automated Equipment LLC

Product names mentioned herein are for identification purposes only, and may be trademarks and/or registered trademarks of their respective companies.

GDF28 Dispenser

INTRODUCTION

The Dispenser is a compact automated system that replaces manual basketing of frozen french fries. The Dispenser automatically weighs 12 ounce (350 gm), 16 ounce (450 gm) or 24 ounce (700 gm) loads of frozen fries and dispenses them into custom fry baskets.

The Dispenser's Hopper holds 42 lbs. (19 kg) of frozen french fries prior to basket loading. A rotating Dispenser Drum inside the Hopper transfers the frozen fries onto the Accumulator Doors where a weight sensor accurately weighs the fries.

Empty baskets are manually placed on the Upper Guide. The baskets slide under the Accumulator Doors where fries are dispensed into them. The Basket Lift then lowers the filled baskets onto the Lower Guide where the baskets wait to be picked up by a crew person.

INTENDED USE

The GDF28 Dispenser is intended to dispense only frozen french fries. All food should be stored and handled according to industry recommendations. The GDF28 Dispenser is not intended to be used for storage of food and should be cleaned regularly as described in the manual in order to avoid spoilage and contamination.

HAZARD COMMUNICATION STANDARD (HCS)
The procedures in this manual may include the use of chemical products. These chemical products will be highlighted with boldface letters followed by the abbreviation (HCS) in the text portion of the procedure. See the HCS Manual for the appropriate Material Safety Data Sheets (MSDS).

NOTE: This equipment is manufactured in the U.S., therefore all hardware measurements are in English, and the metric conversions stated are approximate.

ADAPTIVE WEIGHT TECHNOLOGY

This Dispenser utilizes adaptive weight technology. This allows the optimal parameters used in weighing to be learned for the product being dispensed. It varies the Drum rotation speed to keep the rate of weight gain constant. It takes between 10-20 cycles for the Dispenser to learn the product. The settings will not be changed when the Dispenser is turned OFF, only when the food properties change.

SPECIFICATIONS

Features:

- Bulk storage of 42 lb. / 19kg frozen product
- Manual or automatic Dispense modes
- Electrically driven
- Holds 7 Custom Fryer Baskets
- Disassembles for cleaning

Electrical Requirements:

- U.S./Canada (UL Listed):
110 Volts a.c., 60 Hertz, 1Ø, 0.7 A
- International (CE Marked):
220-240 Volts a.c., 50 Hertz, 1Ø, 2.0A.
- Internal Circuit Breaker: 5 Amps

Additional Equipment Information:

- Noise Emissions: < 70 dB(A)
- Maximum Altitude: 6000 ft. (1525 meters)
- Maximum Humidity: 95% non-condensing
- Ambient Temperature: 4° - 25°C (40° - 77°F)

Date of Manufacture:

The manufacturing date is encoded into the serial number identification label on the side panel of the Dispenser.

Example: S/N GDFR0403C000000 indicates a manufacturing date of 03/04 or March 2004.

Space Requirements:

Clear floor space near fry vat at least 28 inches (72 cm) wide and 24 inches (60 cm) deep. Basket Handles will extend to 32 inches (81 cm). This equipment must be placed on a horizontal surface with a tilt of less than 2 degrees. This equipment is only to be installed in locations where use and maintenance is restricted to trained personnel.

FCC STATEMENT

WARNING: This equipment generates, uses, and can radiate radio frequency energy and, if not installed and used in accordance with the instruction manual, may cause interference to radio communications.

GDF28 Dispenser

WARRANTY

The terms "we", "us", "our" or "factory" hereinafter refer to Automated Equipment LLC. We warrant the purchased product to be free from manufacturing defects in material and workmanship under normal use and conditions for the period and component specified below:

| <u>Components covered</u> | <u>Term</u> |
|--|-------------|
| Electronic Circuit Board Assemblies | 1 year |
| Electrical and Mechanical Moving Parts | 1 year |
| Structural frame work or enclosures | 1 year |
| Crew removable components: | |
| Drip Tray | 90 days |
| Hopper, Hopper Lid, and Diverter | 90 days |
| Drum | 90 days |
| Hopper Extension | 90 days |
| Lift Saddle Assembly | 90 days |
| Guide Assemblies & Slides | 90 days |
| Crumb Tray | 90 days |
| Custom Baskets | 90 days |
| Power Cord | 90 days |

The Warranty period commences on the date of shipment of the Dispenser (hereinafter "Product") from our manufacturing facility.

EXCEPT AS OTHERWISE PROVIDED HEREIN WE MAKE NO OTHER WARRANTIES, EXPRESSED OR IMPLIED AND SPECIFICALLY DISCLAIM ANY WARRANTY OF MERCHANTABILITY OR FITNESS FOR A PARTICULAR PURPOSE.

We shall not be liable for any direct, indirect, consequential damages (including damages for loss of business profits, business interruption, loss of business information and the like) arising out of the use of or inability to use the Product.

THIS WARRANTY IS VOID IF THE PRODUCT IS NOT FUNCTIONING CORRECTLY DUE TO ABUSE OR NEGLIGENCE BY THE PURCHASER, ITS EMPLOYEES, AGENTS, OR OTHER REPRESENTATIVES EITHER BY BREAKING, BENDING, MISUSE, ABUSE, DROPPING, ALTERATION, IMPROPER MAINTENANCE OR ANY OTHER FORM OF NEGLIGENCE OR IMPROPER USAGE. THIS WARRANTY DOES NOT COVER DAMAGE TO THE PRODUCT BY NATURAL CAUSES SUCH AS LIGHTNING, ELECTRICAL CURRENT FLUCTUATIONS, FLOOD, FIRE, TORNADOES, OR OTHER ACTS OF GOD. WE WILL INVOICE PURCHASER FOR REPAIRS MADE NECESSARY BY THE HEREIN LISTED CAUSES.

This warranty is governed by the substantive laws of Minnesota, U.S.A., without giving effect to the conflict of law provisions.

This warranty is non-transferable and applies only to the original purchaser.

GDF28 Dispenser

REQUESTING SERVICE, ASSISTANCE, OR PARTS

WARRANTY SERVICE

Warranty service must be initiated by calling our Technical Support Hot Line at 1-800-248-2724 (U.S./Canada) or 651-385-2273 to establish all warranty requests.

Our Technical Support personnel will determine the cause of failure and provide the appropriate resolution. If replacement parts are required, parts will be provided by the factory or by an authorized Service Support Center/Parts Distributor.

We will make all reasonable efforts to perform such repairs during normal business hours, and will not be responsible for any after-hours or holiday charges.

NON-WARRANTY SERVICE

Service is normally conducted by customer appointed personnel, or by contracting a local service agent. Service fees are in accordance with industry standards.

Replacement parts are available through local Service Support Center/Parts Distributors or direct from the factory by calling 1-800-248-2724 (U.S./Canada) or 651-385-2273 in the event a local distributor is not available.

Our Technical Support Hot Line is available for telephone assistance providing factory product technical support, parts and parts information, and service agent referral. Contact our Technical Support Hot Line at 1-800-248-2724 (U.S./Canada) or 651-385-2273.

Record the following information for your records:

Date of Installation

Service Agency Telephone

Serial Number

When repairing this unit, use only replacement parts supplied by the factory, or supplied by a factory Authorized Parts Distributor. Use of

replacement parts other than those supplied by the factory or by a factory Authorized Parts Distributor will void the warranty.

All charges for parts and shipping are F.O.B. factory, and are subject to change without notice. Prices will be those in effect at the time of shipment.

We reserve the right to make suitable substitutions in materials, depending upon their availability.

WARNING!

Only trained and/or qualified personnel should perform service to this equipment.

Service functions described in this manual could cause irreversible damage to the equipment and/or injury to personnel if performed improperly.

If the power cord is damaged, it must be replaced by the manufacturer or its service agent or a similarly qualified person in order to avoid a hazard.

GDF28 Dispenser

SAFETY

Here are some guidelines for operating and maintaining the GDF28 Dispenser:

- Disconnect the Dispenser Power Cord from the wall outlet before inspecting.
- Inspect the Dispenser on a regular basis to identify problems before they occur.
- Keep the Dispenser clean.
- Keep hands away from the Accumulator Doors and Dispenser Drum while the Dispenser is operating:
- Fryer Baskets may be hot. Pick them up by the handles only.
- Do NOT roll the Dispenser to the back sink for cleaning, this will cause unnecessary wear on the Dispenser.
- If the supply cord is damaged it must be replaced by the manufacturer or its service agent or a similarly qualified person in order to avoid a hazard.
- DO NOT SPRAY DOWN THE DISPENSER WITH WATER. It is not sealed against jetting water and contamination may get into sensitive components. This will void the warranty

WARNING!

**Only trained and/or qualified personnel should perform service to this equipment.
Service functions described in this manual could cause irreversible damage to the equipment and/or injury to personnel if performed improperly.**

INTERNATIONAL SAFETY LABELING

International Safety Labeling is represented with the symbols illustrated below. The labels are affixed to the Hopper to clearly indicate areas that could be harmful to the operator of the Dispenser.

These safety issues are:

1. **BASKETS MAY BE HOT:** Baskets should always be picked up by the provided handle.
2. **NO HANDS BELOW:** Hands should not be placed near or below the Accumulator Doors while the Dispenser is energized.

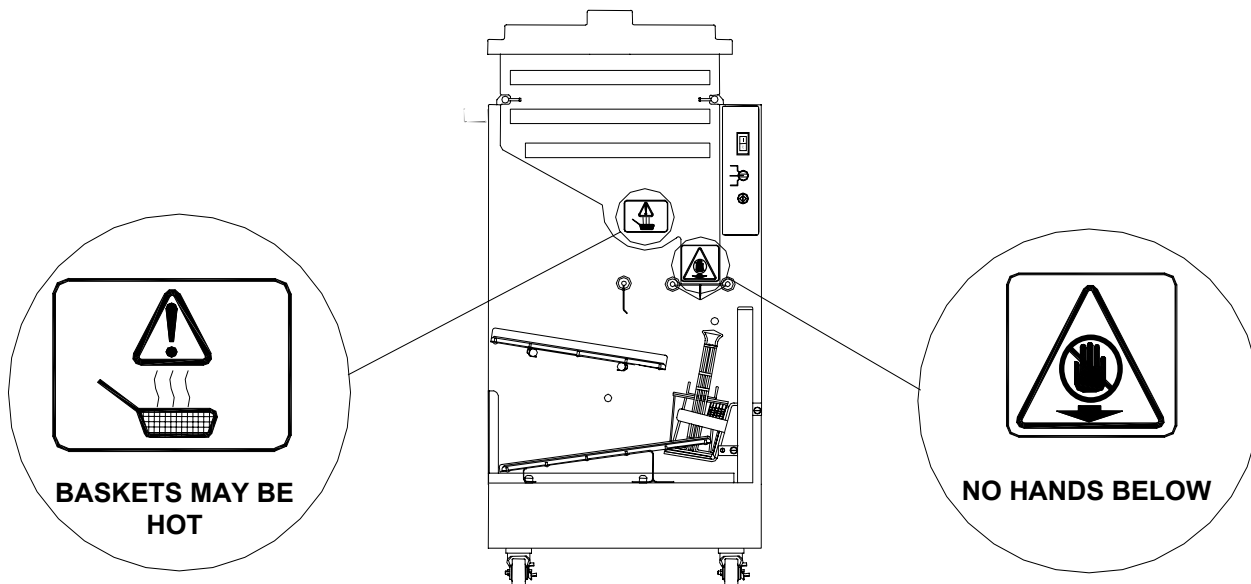

ASSEMBLING THE DISPENSER

INSTALL DRIP TRAY (Fig. 1)

- Position the Drip Tray with the Basket Stop away from the Lift Saddle as shown.
- Slide the end of the Drip Tray under the Lift Saddle.
- Line up the holes in the Drip Tray with the Locator Pins and set the Drip Tray down over the Locator Pins.

INSTALL LOWER GUIDE (Fig. 2)

- Position the Lower Guide with the high end toward the Lift Saddle. The low end should be toward the Basket Stop as shown.
- Line up the holes in the Lower Guide with the Locator Pins and set the Lower Guide down over the Locator Pins.

INSTALL UPPER GUIDE (Fig. 3)

- Locate the Hooked Tab and the Straight Tab on the bottom of the Upper Guide.
- Position the Upper Guide with the Hooked Tab away from the Lift (as shown). Tilt the Upper Guide back so that the end near the Lift is two to three inches (5-10cm) higher than the end with the hooked tab.
- Place the Hooked Tab of the Upper Guide around the LEFT Guide Support. Align the slot in the Hooked Tab with the screw in the middle of the Guide Support, then slide the Upper Guide to the RIGHT, hooking it on the LEFT Guide Support.
- Align the slot in the straight tab of the Upper Guide with the screw on the RIGHT Guide Support. Press the upper guide down, snapping it into place.

INSTALL THE HOPPER AND DRUM (Fig. 4 & 5)

- Find the square opening in one end of the Dispenser Drum.
- Place the Dispenser Drum in the Hopper, aligning the square opening on the Dispenser Drum with the hole in the back of the Hopper.
- Grasp the Hopper so that the hole is toward the Dispenser.
- Align the indentations on the Hopper with the Hopper Support Bars.
- Push the Hopper forward onto the Hopper Support Bars until the Drum Motor shaft touches the Dispenser Drum.

CAUTION: Do NOT force the Hopper back; this could damage the Hopper or Drum.

- Rotate the Dispenser Drum (CLOCKWISE or COUNTER-CLOCKWISE) while applying gentle pressure to the Hopper until you can easily slide the Hopper fully onto the Hopper Support Bars.
- Lock the Hopper onto the Dispenser by pressing the Locking Pins on the ends of the Hopper Support Bars towards each other.

PLACE THE DIVERTER IN THE HOPPER (Fig. 6)

Be sure that it is hooked over the RIGHT edge of the Hopper.

PLACE THE HOPPER LID ON THE HOPPER (Not pictured)

Hook the lid's tab over the back rim of the Hopper, then set the Lid down.

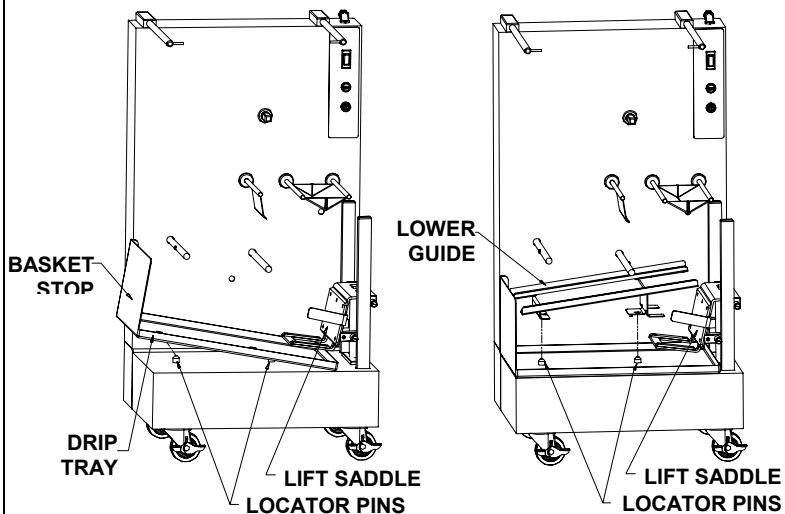

FIGURE 1

FIGURE 2

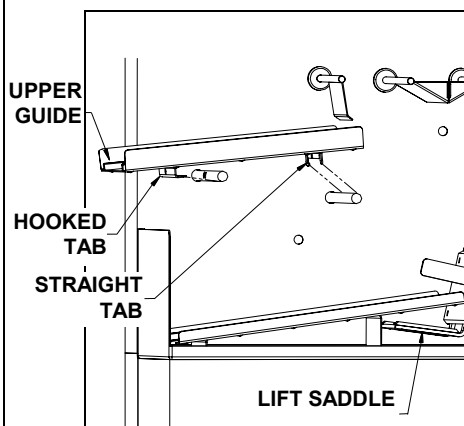

FIGURE 3

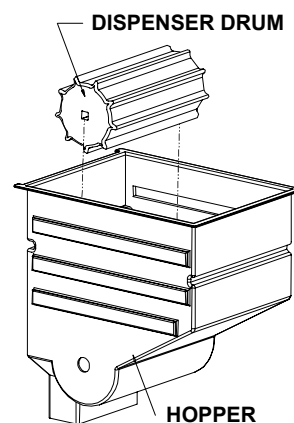

FIGURE 4

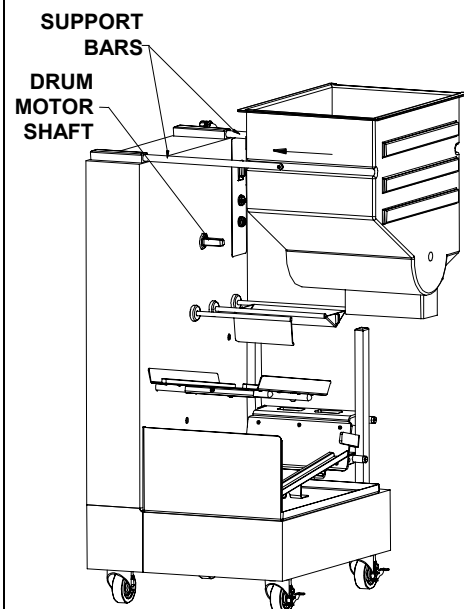

FIGURE 5

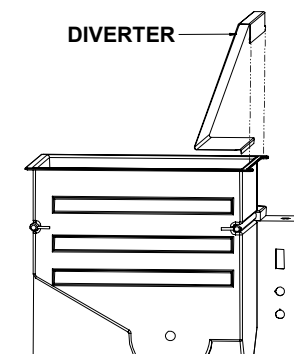

FIGURE 6

GDF28 Dispenser

DAILY SET-UP

1. Verify that the Power Switch is in the OFF position.
2. Plug the Power Cord into a wall outlet.
3. Load the Hopper with frozen french fries. **DO NOT SHAKE OR DROP** the fries into the Hopper (refer to "LOADING THE HOPPER", page 8).
4. Turn the Load Select Switch to the desired load weight.
5. Fill the Upper Guide with empty Custom Baskets.
6. Turn the Power Switch to the ON position (illuminated). Electric motors will orient themselves to starting positions and the dispenser will initiate the filling process.
7. Use filled Baskets from the Lower Guide for Fry production.
8. Return empty Baskets to the Upper Guide for refilling after the cooking cycle is complete.

LOADING THE HOPPER

To achieve optimum fry yield and the most consistent basket loads, it is important to use the following technique for loading frozen fries into the hopper. Depending on your fry supplier, you will receive your french fries packaged in boxes of six pounds each, or bags of six pounds each. These bags or boxes will be packed six to a case. The hopper will accept one full case plus one bag or box of french fries (42 lbs. or 19 kg).

For each bag or box of french fries:

1. Remove the bag or box of french fries from the case. Be careful not to crush the fries.
2. Open the top of the bag or box completely.
NOTE: If your supplier uses bags, be careful that the top is fully open. If it is partially open, the bag may retain fries.
3. Hold the opened end of the box or bag closed with your hand and lay it in the hopper with the opening toward the side opposite of the diverter.
4. Release the opened end of the bag or box.
5. Empty the bag or box into the hopper by pulling it evenly toward the Diverter. When adding multiple bags of fries, alternate the placement of the bag or box in the hopper opposite of the previous bag or box. The second bag of fries should be emptied into the Hopper with the opening toward the Diverter, and pulling it evenly toward the Hopper Wall opposite the Diverter.
NOTE: This criss-cross loading method assures an even distribution of fry lengths in the Hopper and the Baskets.
NOTE: Do NOT shake or drop fries from the bag or box into the Hopper.
NOTE: If the loading is done correctly, you should be able to leave a uniform layer of fries in the hopper by simply pulling the bag or box across the hopper and then out of the hopper.
6. Repeat steps 1 through 5 until the hopper is full.
NOTE: Do NOT fill the hopper past the top.
7. Close the lid on the hopper by engaging the hook at the back of the hopper, and setting the lid down

DAILY CLOSING

1. Turn the Power Switch to the OFF position.
2. Remove all Baskets from the upper and Lower Guides. Discard and record the uncooked fries.
NOTE: During the last few hours of the day, you may want to keep only two or three bags of french fries in the hopper and run the dispenser in SINGLE mode, to minimize waste.
3. Remove the Hopper Lid by lifting it UP and BACK to unhook the tab.
4. Hang the hopper lid on the front of the hopper, by hooking the tab on the lip of the hopper.
5. Discard and record any fries remaining in the Hopper at closing.
6. Check that the Accumulator Doors are empty of fries.
7. Disconnect the Power Cord from the electrical outlet
8. Remove the Diverter by grasping it and pulling it UP.
9. Slide the Locking Pins outward to release the Hopper.
10. Remove the Hopper (and the Dispenser Drum inside) by pulling the Hopper OUT and AWAY from the Hopper Support Bars.
11. Remove the Upper Guide assembly by lifting the RIGHT end and sliding it to the LEFT.
12. Remove the Lower Guide by lifting it straight UP.
13. Remove the Drip Tray by lifting it from the Basket Stop end and sliding it from under the saddle.
14. Take the hardware removed from the Dispenser to the back sink. Wash it in a hot solution of **McD APSC (HCS)**, rinse with clear water, sanitize and allow to air dry.
15. Roll the dispenser out from the wall, so that you can clean behind it and underneath it.
NOTE: Do NOT roll the dispenser to the back sink for cleaning, this will cause unnecessary wear on the dispenser and possible premature failure.
16. Wipe down the dispenser with a hot solution of **McD APSC (HCS)** and water. Repeat wipe-down with clear water, sanitize and allow to air dry.
NOTE: DO NOT SPRAY DOWN THE DISPENSER. It is not sealed against jetting water and contamination may get into sensitive components. SPRAYING MAY VOID THE WARRANTY!
17. Reassemble the dispenser.
18. Roll the dispenser back into place.

WARNING **PINCH HAZARD**

Personnel should take care not to place hands or fingers near the Drum inside the Hopper, while this machine is in operation. Hands or fingers could be pinched between the Drum and the Hopper as the Drum turns.

GDF28 Dispenser

OPERATOR CONTROLS

The following switches and buttons are located on the Operator Panel:

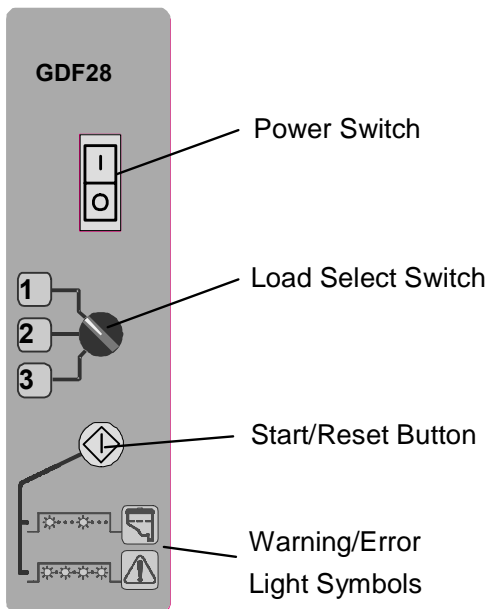

Power Switch (Orange)

The Power Switch supplies electrical power to the Dispenser. It illuminates when the Dispenser has power. The Power Switch also functions as a circuit breaker for the machine.

LOAD SELECT SWITCH

The Load Select Switch has 3 positions that allow the operator to select Basket Load weights and control operation.

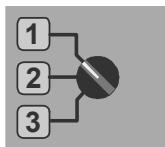

Position #1: Single basket loading. Press the Start/Reset Button to dispense a single basket of Fries. Pre-set to .75 lb./350 gm/Single mode.

NOTE: International units are factory set to automatic mode. US and Canadian units are factory set to single mode. This can be reconfigured by performing function #6 (see page **Error! Bookmark not defined.** & 13).

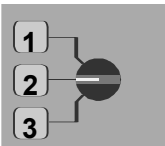

Position #2: Automatic dispensing of 1.0 lb./450 gm Basket Loads.

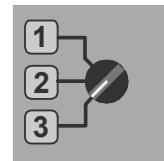

Position #3: For Automatic dispensing of 1.5 lb./700 gm Basket Loads.



Start/Reset Button (Green)

Press to start the loading of a single Basket if the Load Select Switch is set for Position #1 (0.75 lb./350gm). Press to reset a System Error or an empty Hopper warning.

The symbols below the button provide an explanation of warning and error conditions.

A **slow blink** (about 1 per second) of the Start/Reset Button indicates either an empty Hopper or bridged appetizers.

A **fast blink** (about 5 per second) of the Start/Reset Button indicates a system error.

CALIBRATE WEIGHT SENSOR

For optimum performance, the weighing system should be calibrated once per year. US Dispensers will need two 1lb weights (eight ¼ lb hamburger patties will work). International Dispensers should use two 450gm weights. To calibrate, follow these steps:

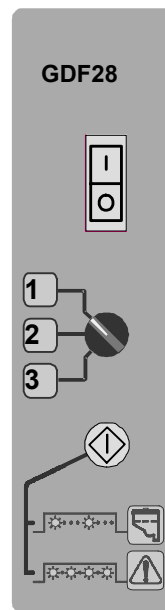

1. Turn the Dispenser OFF (O). **Wait 15 seconds**
2. Remove the Hopper and Drum to gain access to the top of the Accumulator doors.
3. Place Selector Switch in Position 1.
4. While holding the Start / Reset Button in, Power the Dispenser ON (I).

GDF28 Dispenser

5. Continue holding the Start / Reset Button in until the Green Light flashes rapidly, and then release.
6. Place an empty Basket on the Upper Guide. Any product remaining on the Accumulator doors will be dispensed into the Basket before calibration continues. After dispensing, the Green light will stop flashing.
7. Place the Selector Switch in Position 2. The Green Light will begin to flash again.
8. Place 1.0 lb. (450gm) On the Accumulator Doors.
9. When the Dispenser has reached a stable value, the Green Light will stop flashing.
10. Place the Selector Switch in Position 3. The green Light will begin to flash.
11. Place an additional 1.0 lb. (450gm) On the Accumulator Doors, for a total of 2 lbs (900gm).
12. When the Dispenser has reached a stable value, the Green Light will stop flashing.
13. Turn the power OFF (**O**).
14. Remove the weight from the Accumulator Doors.
15. Replace the Hopper and Drum
16. Place the Selector Switch in the desired Basket size position.
17. Power the Dispenser ON (**I**).
18. The Green Light will illuminate indicating the Dispenser is ready for Normal Operation.

FRONT PANEL OPERATIONS CUSTOMIZATION (Bypass Mode)

Bypass Mode will allow the dispenser to remain functional in the event the weighing system or the basket sensors fail.

NOTE: The BYPASS mode has two methods of operation and the Dispenser will automatically select the appropriate method.

Method 1:

The Dispenser detects a functioning Weight Sensor.

The Dispenser will appear to operate normally, filling the accumulator with the correct weight of appetizers. The Start/Reset button must be pushed to dispense the appetizers into a basket. This method allows the Dispenser to operate with faulty basket sensors.

Method 2:

The Dispenser detects a failed Weight Sensor.

Holding in the Start/Reset Button, the Drum will turn to dispense appetizers onto the Accumulator Doors. Releasing the Start/Reset Button stops the Drum motor, opens the Accumulator doors, closes the Stopgate, and then lowers the filled Basket. After lowering the Basket, the Lift Saddle will come back up and the Stopgate will open to allow the next Basket to move into the Lift Saddle for filling.

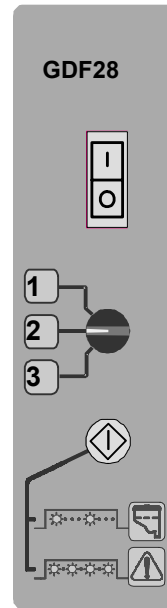

To Engage the BYPASS Mode of operation:

- Turn the Dispenser off. **Wait 15 seconds.**
- Select Position #2.
- Hold in the Start/Reset Button
- While holding in the Start/Reset Button, turn the Dispenser power ON (**I**). Double flashing of the Start/Reset button indicates BYPASS

This modification to the Dispenser operation is temporary:

When the Dispenser power is turned OFF (**O**), the Dispenser resets to normal operations when the power is turned ON (**I**) again.

NOTE: Allow 15 seconds before turning the Dispenser Power Switch ON (**I**) after being turned OFF (**O**).

NOTE: The Bypass mode will significantly slow down the operations of the Dispenser. The Start/Reset button has to be used in either mode of Bypass operation.

GDF28 Dispenser

SEQUENCE OF OPERATION

Initial Power Up

The chart below is an example of the Dispenser's sequence of operations under the following conditions:

- The Hopper is fully loaded with french fries and properly installed on the Dispenser.
- There are 2 empty Baskets on the Upper Guide.
- There are no empty Baskets on the Lower Guide.
- The Dispenser Load Switch is in the 1.0 lb./450 gm position.

NOTE: The time for one basketing cycle is approximately 4 - 6 seconds.

| Event | Response |
|--|--|
| Power Switch Turned ON | Stopgate moves to the home position. The Lift moves to the home position, pauses, then raises to the up position. |
| Dispensing Begins. | The Drum turns and fries are dispensed from the Hopper to the Accumulator Doors. The Accumulator Doors weigh the fries and signal to stop the Drum Motor when the 1.0 lb. (450 gm) weight is attained. |
| Stopgate opens. | When the weight is attained the Stopgate opens to allow a Basket to slide into the Lift Saddle. |
| Accumulator doors open and empty. | A sensor in the chassis of the Dispenser detects the Basket. If a Basket is not present, the Dispenser will wait until it detects the Basket. When the Basket is present, the Accumulator Doors open to dispense the fries into the Basket. |
| Stopgate Closes | The Stopgate closes to allow clearance of the filled Basket in the Lift Saddle. |
| Lift Saddle lowers Basket. | The Lift Saddle lowers the filled Basket to the Lower Guide. As the Basket slides down the Lower Guide, another sensor detects the Basket arriving on the Lower Guide.. |
| Accumulator Doors close. Lift Saddle raises up. | The Accumulator Doors close and the Lift Saddle raises to the up position. |
| Stopgate opens. | Stopgate opens to allow the next empty Basket to slide into the Lift Saddle. |
| Restart of Dispensing. | Cycle starts over again. Dispensing Begins After filling the second Basket, the Dispenser will stop because there will not be a Basket detected in the Lift Saddle. |

GDF28 Dispenser

FUNCTION LIST

The following is a complete list of the available functions.

| Number | Function Name | Description |
|--------|-----------------------|--|
| 1 | restart function | Same as Start/Reset Button on front panel. |
| 2 | display last error | Displays the last error number recorded. |
| 3 | weigh disable | Turns the weighing cycle on and off. |
| 4 | tare function | Not used. |
| 5 | calibrate | Accepts 16oz (450gm) and 32 oz. (900 gm) reference weights; sets the 12 oz. (350 gm) and, 16 oz. (450 gm), and 24 oz. (700 gm) targets. |
| 6 | adjust_Pos1 | Programs selector switch position 1: (<i>Default: 12 Oz./350 gm, Manual, Single Load</i>). Sub-Function 1 - Increases weight setting. Sub-Function 2 - Decreases weight setting. Sub-Function 3 - Sets "SL" (single load) or "AU" (automatic dispense) Sub-Function 4 - Sets "1" (single) or "2" (double) Load Sub-Function 5 - Closes F6 Sub-Functions. |
| 7 | adjust_Pos2 | Programs selector switch position 2 (Default:16 Oz./450 gm, Automatic, Single Load). Sub-Functions same as Function 6. |
| 8 | adjust_Pos3 | Programs selector switch position 3 (Default:24 Oz./700 gm, Automatic, Single Load). Sub-Functions same as Function 6. |
| 9 | not used | |
| 10 | watchdog test | Generates a signal to the program so that the watchdog timer fires. Invokes error #8 (not displayed). |
| 11 | weight sensor readout | Displays the current reading from the weight sensor (live display). |
| 12 | actuate lift | Moves the lift up and down. Displays the Lift position counts (position of the lift). |
| 13 | actuate doors | Opens and closes the accumulator doors. |
| 14 | actuate stopgate | Opens and closes the stopgate. |
| 15 | actuate drum | Turns the drum motor on and off. Displays speed (16 ... 0), varies with each press of the Enter button. |
| 16 | actuate light | Turns the restart light on and off. |
| 17 | restore defaults | Clears the error log, sets default weighing parameters, defaults lift counts to 102. |
| 18 | clear errors | Clears the error log. |
| 19 | error counts | Displays the error log. |
| 20 | parameters | Always displays default values. |
| 21 | not used | |
| 22 | not used | |
| 23 | not used | |
| 24 | bypass mode | Enables the dispenser to run in "Bypass", single mode. Ignores select system errors. |
| 25 | set units | Sets weighing units to ounces "US", or grams "In" International. |
| 26 | exercise mode | Enables exercise mode, all motor functions cycle. |
| 27 | rev | Displays revision level of installed EPROM |
| 28 | segment test | The segments will illuminate in a moving display mode. |
| 29 | lift up counts | Displays Lift Up position counts. Default range is from 77 (bottom) to 179 (top). |
| 30 | adjust lift down | Decreases the Lift Up position, 1 count = 1/12" (2.1 mm). Number of counts is displayed. |
| 31 | adjust lift up | Increases the Lift Up position, 1 count = 1/12" (2.1 mm). 105 counts maximum. Number of counts is displayed. |

GDF28 Dispenser

CONTROLLER FUNCTIONS

In the back of the Dispenser, in the upper right corner of the controller circuit board is the service interface. This is used to adjust the basket load sizes and to test and adjust the operation of the Dispenser.

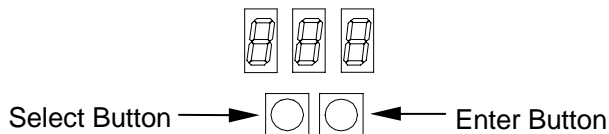

The following sections discuss the modes of this display:

Normal Operation

During Normal Operation, the display will show a series of horizontal bars, as shown below.

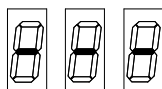

Error Conditions

When an error occurs, the Start/Reset Button will flash rapidly (5 times per second) and the Lift Saddle will go down. Normally, an error condition can be cleared by pressing the Start/Reset Button. If an error persists or occurs too often, you may need to know what error is occurring. For this purpose, when an error occurs, the center line of the display is replaced with an error code. The example below is displaying error code 4.

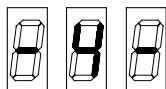

A complete list of the error codes is given in the troubleshooting section (See page 25).

The controller has several functions that may be used to adjust and test the functions of the Dispenser. These are accessed using the following procedure.

1. Press the Select Button the number of times as the function number desired. Each time you press the Select Button the display will show the function code for the function that is ready. The example below shows Function 7: (Adjust Basket Weight, Switch Position #2, DOWN.)

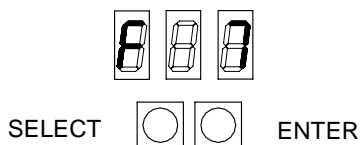

NOTE: If you leave the display in this mode, it will return to Normal Operation after a few seconds. This is a safety feature, to prevent functions from being selected by accident.

2. When the display shows the desired function number, press the Enter Button to activate the function.

What happens next depends on the function selected. Pressing the Select Button will close the function; pressing the Enter Button will advance the function to the next step. The following is a detailed account of each function.

Function 1 – Restart

Returns immediately to the normal display. This function serves the same purpose as the Start/Reset button on the front panel.

Function 2 - Display Last Error

Displays the last error number recorded. This allows the Dispenser to be restarted after an error, and then find out what the error was while the Dispenser is in service.

Function 3 - Disable Weighing

Turns the weighing process on and off. This is used for testing of the mechanical systems. It allows you to work on the dispenser without weighing fries. This is a temporary setting and will automatically reset on power up.

Function 4 – Not Used (NCWS)

Function 5 – Calibrate (NCWS)

Displays the word “CAL” on the display. Verify the doors are empty and press the ENTER button: the display will respond “C1.0.” Place 1.0 lb./ 16 ounces / 450 gm. on the door, wait 10 seconds and press the ENTER button: the display will respond “C2.0.” Place 2.0 lbs. / 32 ounces / 900 gm. on the door, wait 10 seconds and press the ENTER button: the display will return to the normal “- - -.” Remove the weights. The unit is now calibrated. When finished, turn machine off, wait 15 seconds, turn machine back on.

Function 6 - Load Select Button #1

(Default: US 12 Oz, Manual, Single Load
International 0.350kg, Automatic, Single Load)
Press ENTER to enter the first Sub-Function:

Sub-Function 1 - Increases weight setting (1oz/.025kg). Display reads the current weight setting (default is US 12 / IN .35).

Successive activation of the ENTER button **increases** the value (13, 14, 15, etc. / .37, .40, .42, etc.). Pressing the SELECT button again, closes this Sub-Function and advances to the next F6 Sub-Function:

Sub-Function 2 - Decreases weight setting (1oz/.025kg).

Display reads the current weight setting, preceded by a minus sign (default is -12 / -.35).

Successive activation of the ENTER button **decreases** the value (-11, -10, -09, etc. / -.32, -.30, -.27, etc.). Pressing the SELECT button again closes this Sub-Function and advances to the next F6 Sub-Function:

Sub-Function 3 - Sets “SL” (single load) or “AU” (automatic dispense). The default is “SL”.

GDF28 Dispenser

Successive activation of the ENTER button toggles the display between "SL" and AU".

Pressing the SELECT button again closes this Sub-Function and advances to the next F6 Sub-Function.

Note: Two dispense cycles are needed before the change from Automatic to Manual takes effect.

Sub-Function 4 - Sets "1" (single) or "2" (double) load. Display reads "1" or "2".

Successive activation of the ENTER button toggles the value between "1" (single) and "2" (double) load.

Pressing the SELECT button again, closes this Sub-Function and advances to the next F6 Sub-Function:

Sub-Function 5 - Closes F6 Sub-Functions. Display reads "END" (end of available Sub-Functions). Pressing the ENTER button closes the F6 functions.

OR

Pressing the SELECT button, will result in a return to Sub-Function 1.

Function 7 -Program Switch Position 2

*(Default: US 16 Oz, Automatic, Single Load
International 0.450kg, Automatic, Single Load)*

Programs switch position 2. Functions are the same as for Switch Position 1 (*Function 6*).

Function 8 - Adjust Switch Position 3

*(Default: US 24 Oz, Automatic, Single Load
International 0.700kg, Automatic, Single Load)*

Programs switch position 3. Functions are the same as for Switch Position 1 (*Function 6*).

Function 9 -NOT USED

Function 10 - Watchdog Test

Causes an Error 8.

Function 11 – Weight Sensor Readout (NCWS)

Displays the current weight sensor reading and is used to test the weight sensor. This is a live display, changing constantly with the weight sensor input. Use function 11 to check the operation of the weight sensor. Applying 1 lb./450gm of weight to the accumulator doors will cause a deflection of approximately 100 counts to the readout. Press the Select button to close the function. NCWS tare should be 30 (+/-9).

Function 12 - Actuate Lift Saddle

The display shows the live lift position. Each time the Enter Button is pressed, the controller will change the state and direction of motion for the circuitry that drives the Lift Saddle. If the Lift Saddle is down, it will go up. If it is up, it will go down. Press the Select button to close the function.

Function 13 - Actuate Doors

Display remains "F13". Each time the Enter Button is pressed, the controller will activate the Accumulator Doors for one cycle. They will open or close. Press the Select button to close the function.

Function 14 - Actuate Stopgate

Display remains "F14". Each time the Enter Button is pressed, the controller will change the state and direction of motion for the circuitry that drives the Stopgate. If the Stopgate is open, it will close. If the

Stopgate is closed, it will open. Press the Select button to close the function.

Function 15 - Actuate Drum

The display shows the drum speed (16: fastest, 0: slowest). Each time the Enter Button is pressed, the controller will change the speed (16.....0 -16) of the Dispenser Drum. This function is used to test the Drum Motor. Press the Select button to close the function.

Function 16 - Actuate Light

Display remains "F16". Each time the Enter button is pressed, the controller will change the state of the output that drives the Start/Reset Light. If it is off it will turn it on. If it is on it will turn it off. This function is used to test the Start/Reset Light. Press the Select button to close the function.

Function 17 - Restore Defaults

This function clears the error log, and restores the weighing parameters and lift height values to factory defaults. Calibration and lift height must be reprogrammed.

NOTE: Function 17 will reset Int'l units to US units. Function 25 can be performed to return to "Int'l" status.

Function 18 - Clear Errors

This function resets the counts in the error log to zero. We recommend that this be done periodically to prevent records of occasional errors from building up (even a perfectly running dispenser will get occasional errors from improper handling) and confusing a service tech at a time when the error log could be useful.

Function 19 - Error Counts

Displays the word "Err". Each time the Enter Button is pressed, it moves to the next error count. When the last count is passed, the display returns to normal mode. The error counts are displayed in numerical order. Error number 9 is not included (error number 9 indicates a memory failure, and therefore renders any history meaningless). For example, if you saw this sequence of displays:

"Err"
"1. 0"
"2. 0"
"3. 1"
"4. 3"
"5. 2"
"6. 0"
"7. 21"
"8. 0"

This would indicate that, since the last time the errors were cleared, there had been one error 3, 3 error 4's, 2 error 5's, and 21 error 7's.

GDF28 Dispenser

Function 20 - Parameters

Displays the word "Con". Each time the Enter button is pressed, it moves to the next weighing parameter. When all parameters have been displayed, the display returns to the normal mode.

The weighing parameters are (in order of appearance):

1. Switch position #1 target - the number of digitizer steps that represents .75lbs/12 oz./350gm. The default value is 75 US / 70 INTL (NCWS).
2. Switch position #2 target - the number of digitizer steps that represents 1.0lb/16 oz./450gm. The default value is 100 US / 90 INTL (NCWS).
3. Switch position #3 target - the number of digitizer steps that represents 1.5lb/24 oz./700gm. The default value is 150 US / 140 INTL (NCWS).

If the loads have been adjusted, these may be slightly different. The tare value after calibration should be approximately 30 (+/- 9). For details, see the section on operation/ calibration of the weight sensor. (NCWS)

Function 21 – Not Used

Function 22 – Not Used

Function 23 – Not Used

Function 24 - Bypass Mode Enable (volatile setting)

Entering this function the display will read either "nor," (normal) Bypass mode disabled, or "bYP", Bypass mode enabled. BYPASS mode allows the machine to run in single mode when an optical sensor has failed. The "BYPASS" mode has two methods of operation:

Method 1:

The Dispenser detects a functioning Weight

Sensor. When the Start/Reset Button is pressed, the Dispenser utilizes the Weight Sensor to determine the weight of the frozen appetizers. The Dispenser will appear to cycle normally, ignoring other system errors.

NOTE: Bypass Mode is significantly slower than normal operation.

NOTE: All settings function in single basket operation while in Bypass Mode.

Method 2:

The Dispenser detects a failed Weight Sensor.

Holding in the Start/Reset Button, the Drum will turn to dispense frozen appetizers onto the Accumulator Doors. Releasing the Start/Reset Button stops the Drum motor, opens the Accumulator Doors closes the Stopgate, and lowers the filled Basket.

After lowering the Basket, the Lift Saddle will come back up and the Stopgate will open to allow the next Basket to move into the Lift Saddle for filling.

The Bypass Mode is further identified by double flashing of the reset button.

NOTE: The Bypass mode will significantly slow down the operations of the Dispenser. The Start/Reset button has to be used in either mode of Bypass operation.

Function 25 - Select Weight Units "US" or "In"

Entering this function permits selection of ounces or grams as the weighing units. Pressing the enter button will toggle the display between ounces "US" and grams "In" (international) for the weight units. Pressing the Select Button sets the displayed weight units for dispenser operations. The weight sensor should be calibrated after changing this setting.

Function 26 - Exercise Mode (volatile setting).

When the dispenser is in the exercise mode, all systems will continuously cycle. The exercise mode is designed to "break in" a replaced component. The exercise mode is volatile and will reset when the dispenser power is turned off.

Function 27 - Display EPROM Revision Level.

The readout will display the revision level of the installed EPROM.

Function 28 - Segment Test

Verifies that all display segments are functional. The segments will illuminate in a moving display mode.

Function 29 - Lift Position Counts

The readout will display the encoder counts for the lift and will change as the lift travels up or down. Default is 77 at the bottom of travel and 179 at the top of travel.

Function 30 - Adjust Lift Down

The readout will display the current or default value for the Lift height (102). Each time the Enter button is pressed, this value will decrease by 1, or approximately 1/12" (2.1 mm). The Select button must be pushed after lowering the lift height to complete the change. The new height setting will take effect on the next lift cycle.

Function 31 - Adjust Lift Up

The readout will display the current or default value for the Lift height (102). Each time the Enter button is pressed, this value will increase by 1, or approximately 1/12" (2.1 mm). The Select button must be pushed after raising the lift height to complete the change. The lift will raise slightly each time the count is incremented.

NOTE: Do not adjust the lift height to compensate for bent saddle/shoulder screws. Maximum recommended lift height is 105. An adjustment of 106 and higher may result in damage to the controller PCB.

GDF28 Dispenser

ERROR CODES

The status of the Dispenser is displayed on the Start/Reset Button light. When the Hopper is filled and operating automatically, the Start/Reset Button remains steadily illuminated. When a System Error occurs, the Start/Reset button flashes rapidly (about 5 per second). System Errors are a result of incorrectly assembling the Dispenser, or an interruption in the normal operation. System Errors are also displayed inside the Dispenser on the controller PCB. Each error has its own error code; these are summarized below.

| Number | Error Name | Definition |
|----------|---------------------------|--|
| Error #1 | ACCUMULATOR TIME-OUT | Accumulator Home Switch fails to turn off within 0.6 seconds of the motor being turned on, or it fails to turn on within 5.0 seconds of the motor output starting. Error will occur if the motor or home switch is disconnected, obstructed, broken, or the associated input or output on the controller PCB has failed. |
| Error #2 | LIFT MOTION | Error will occur if the motor or encoder inputs are disconnected, or the associated input or output on the controller PCB has failed. Error will occur if there is a physical obstruction of Lift Saddle or damage to Lift Saddle components. Error will occur if there is a Failure of lift drive motor w/ gear box, lift tube, encoder, or encoder disk. |
| Error #3 | STOPGATE MOTION | The stop gate allows 1.0 second to home itself. Error will occur if the motor or home switch is disconnected, obstructed, broken, or the associated input or output on the controller PCB has failed, or if the Hardstop screw is broken off. |
| Error #4 | LIFT SENSOR | The controller PCB has sent the Lift Saddle down and the controller PCB is still receiving the Lift sensor input. Sensor is operating out of sequence. |
| Error #5 | GUIDE SENSOR | The controller PCB has not received a signal from the guide sensor after the Lift is down. The Guide Sensor has failed to detect a Basket leaving the Lift Saddle. |
| Error #6 | Not Used | |
| Error #7 | ENCODER SEQUENCE | This is caused by both of the encoder sensors changing at the same time. If the count rate of the encoder exceeds 100 counts per second (normal speed is 51 counts) or something electrically interferes with the encoder sensors, the error would occur. This error could also be caused by contamination. |
| Error #8 | ABNORMAL RESET (WATCHDOG) | An event other than a normal power up has caused the processor to restart. This could be a watchdog reset, (indicating that the processor has hung or Function 10 was entered), a processor reset (an EMI/RFI problem), or the processor has detected corrupted memory. NOTE: Error code #8 is not displayed. |
| Error #9 | NVRAM CHECKSUM | The processor writes the permanent data (error logs, configuration, and operating parameters) along with extra data that it uses to verify the data is valid. Data may be invalid for several reasons: <ul style="list-style-type: none"> a) The first time the controller PCB has been used. b) Software upgrade. (When new software has a different memory configuration). c) Power down interrupted a Non Volatile RAM write cycle. The write cycle usually happens when the reset button is pressed to reset an error. d) The NVRAM has failed |

GDF28 Dispenser

NOTE:

- All "L" numbers refer to numbered LEDs on the controller board. (see Page 29 & 30)
- All "F" numbers refer to controller functions. (see Page 13)

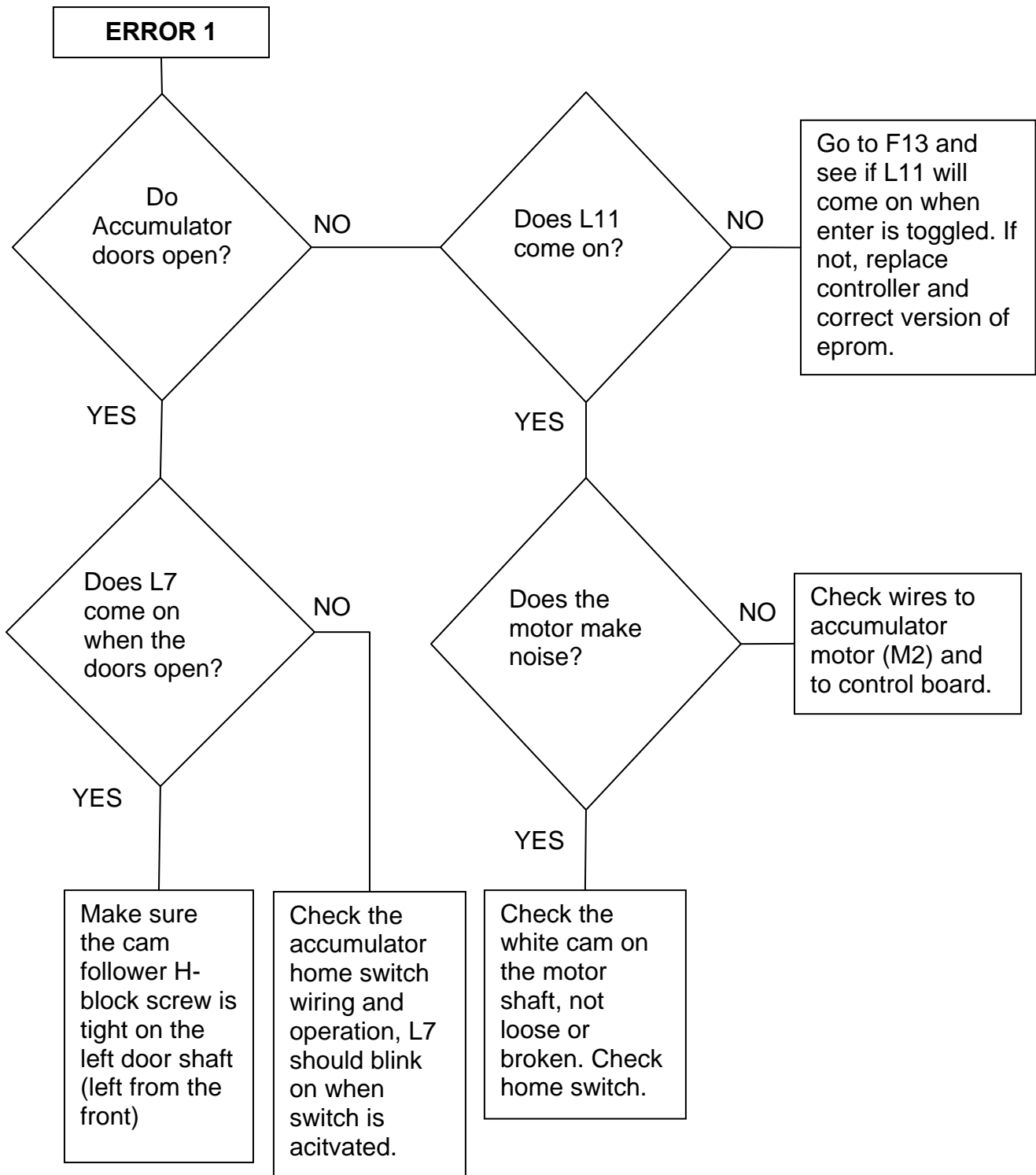

GDF28 Dispenser

ERROR 2

Does the lift move at power up?
Should go down first, unless already there.

NO

YES

Check wiring connections at motor and at output #1, terminals 5 and 6 on controller board. Also check board for corrosion.

Remove lift tube and press reset, does motor run?

YES

Check lift tube, should move smoothly. If not, replace or clean/relube it.

NO

Remove lift motor wires 5,6 on input one, and hot-wire to the 24v input plug by touching the wires on the screws.

Does the motor spin both directions?
(Reverse wiring)

YES

Replace the controller board, 290626. Verify proper software.

NO

Replace the lift drive motor 290147

Does the lift move both directions, or just one way?

BOTH

Check the saddle for binding. Check lift height setting (F30), not to exceed 106. Remove lift tube, check for binding. Check lift motor for water damage.

ONE

Check for water damage to controller board and plugs. Replace controller 290626, and appropriate version of software.

With lift tube out, and while still in a system error, manually verify encoder operation. Using a flat blade screwdriver, place blade inside center of motor next to the center pin. Be careful not to damage encoder disk/vane. Turn the handle either direction. L4/5 should go on/off completely, but never change at the same time. Also check encoder disk/vane for damage. Replace both encoders or disk/vane as needed.

GDF28 Dispenser

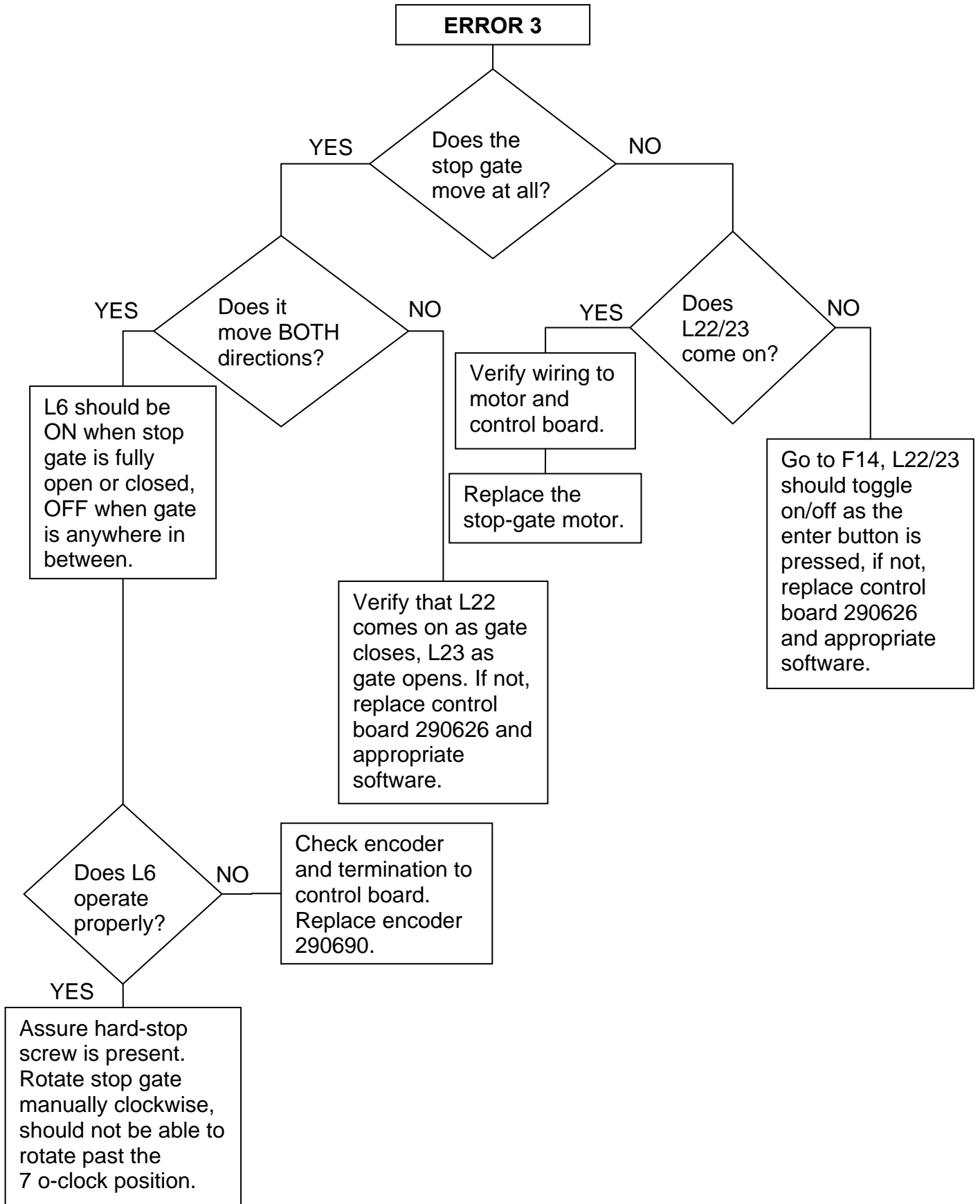

GDF28 Dispenser

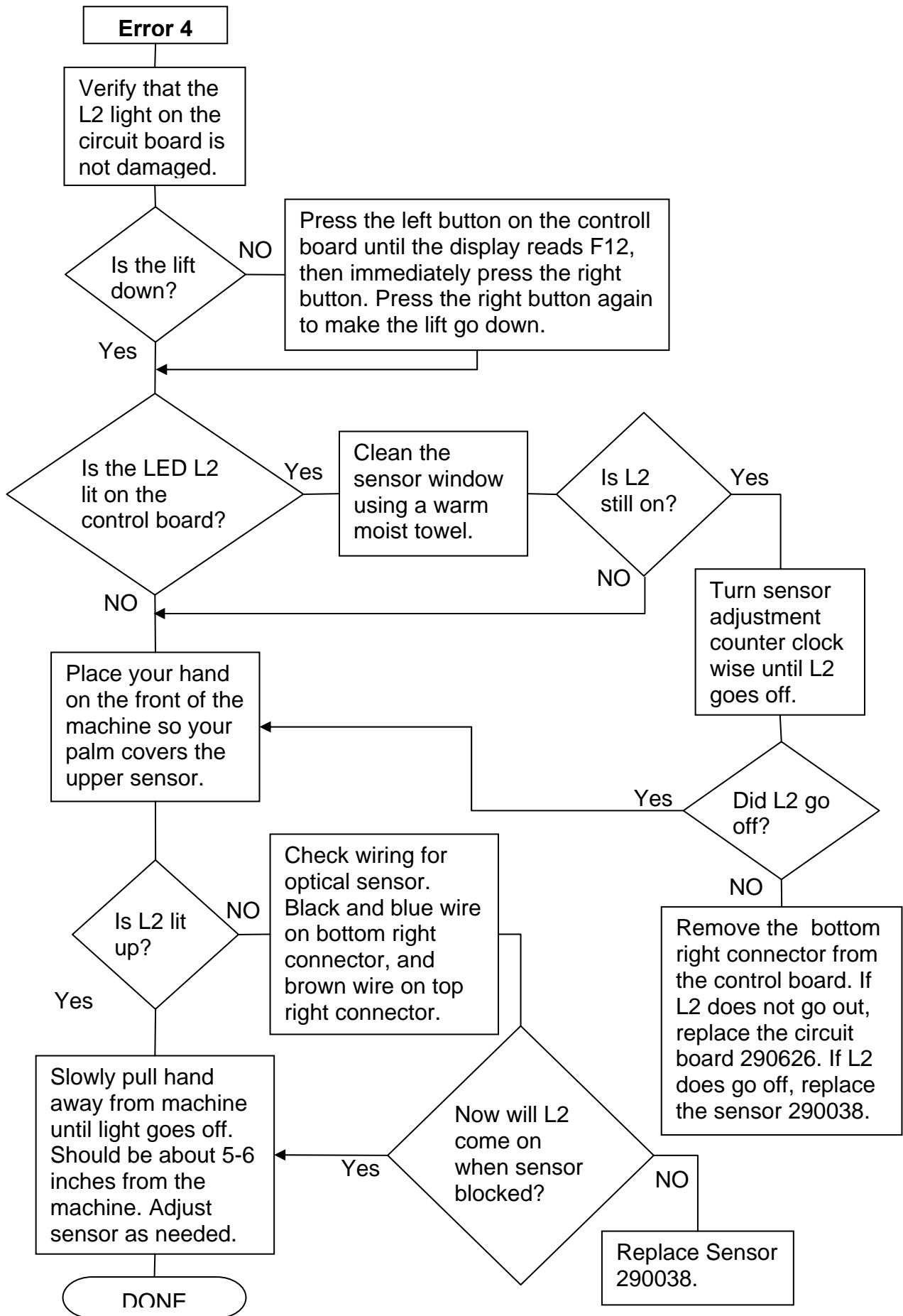

GDF28 Dispenser

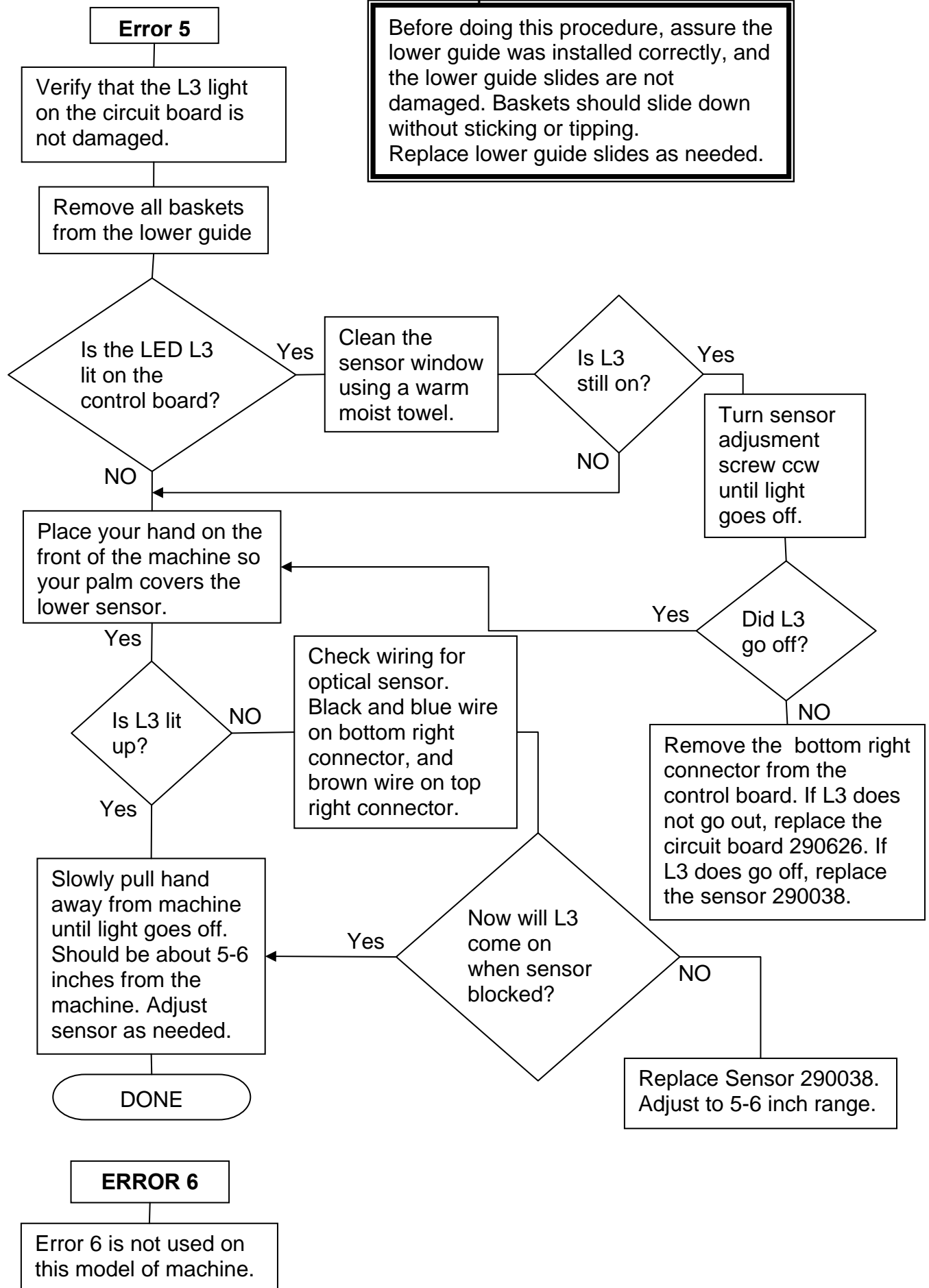

Before doing this procedure, assure the lower guide was installed correctly, and the lower guide slides are not damaged. Baskets should slide down without sticking or tipping. Replace lower guide slides as needed.

GDF28 Dispenser

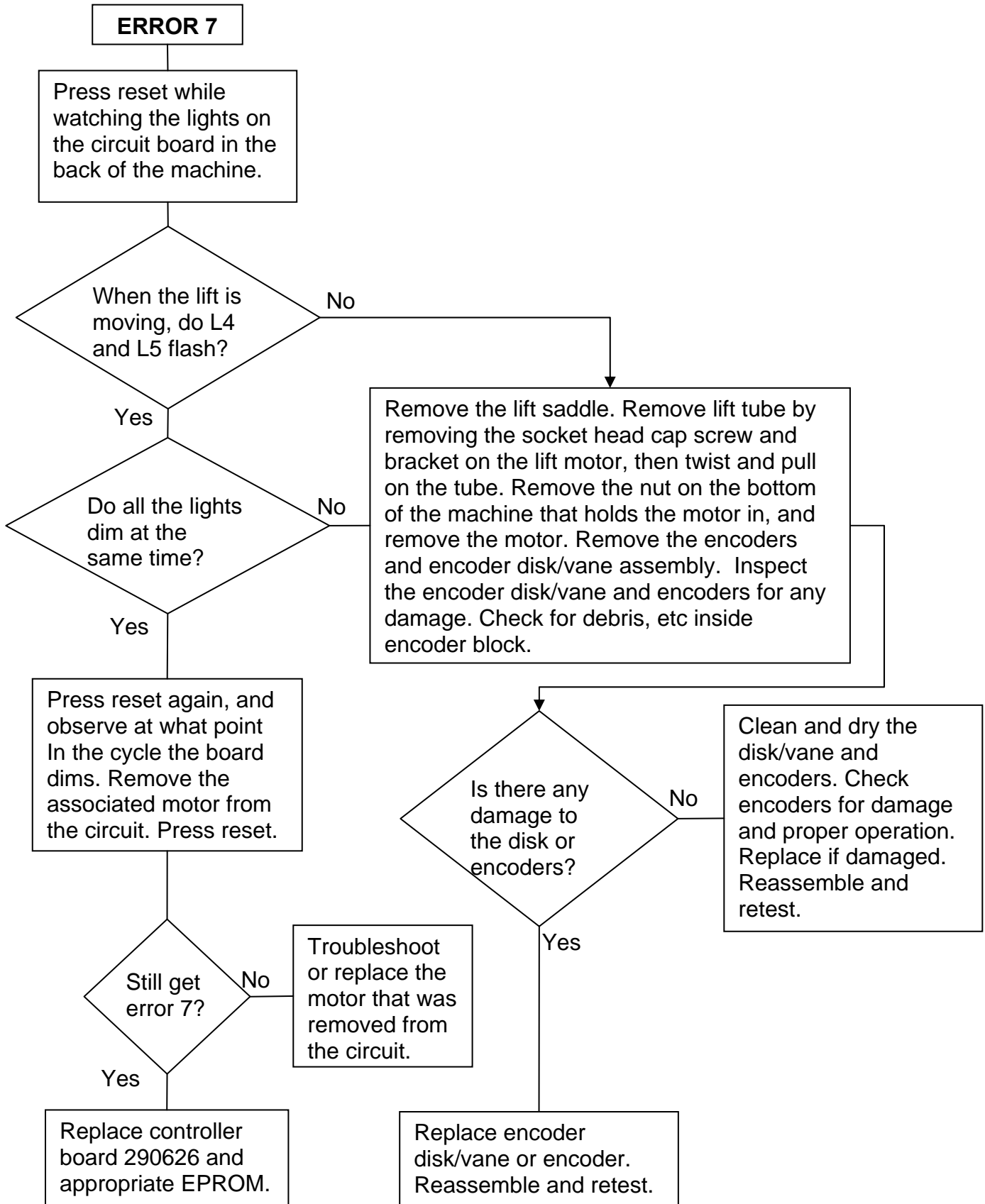

GDF28 Dispenser

ERROR 8

Check power cord, on/off switch, and power supply connections. Replace/repair as needed.

This error means the program is being reset by means other than the reset button. Error 8 automatically resets by itself, so it will not show up on the display. The only way to check for error 8 is to access the error log by going to function 19, and pressing the Enter button 9 times. Some error 8's are to be expected, as it can be caused by turning the machine on/off too quickly. If problem persists, call Automated Equipment LLC for technical support.

ERROR 9

Turn the machine off for 15 seconds and turn it back on.

Error 9 is normal for the first time a machine is turned on after replacing an EPROM.

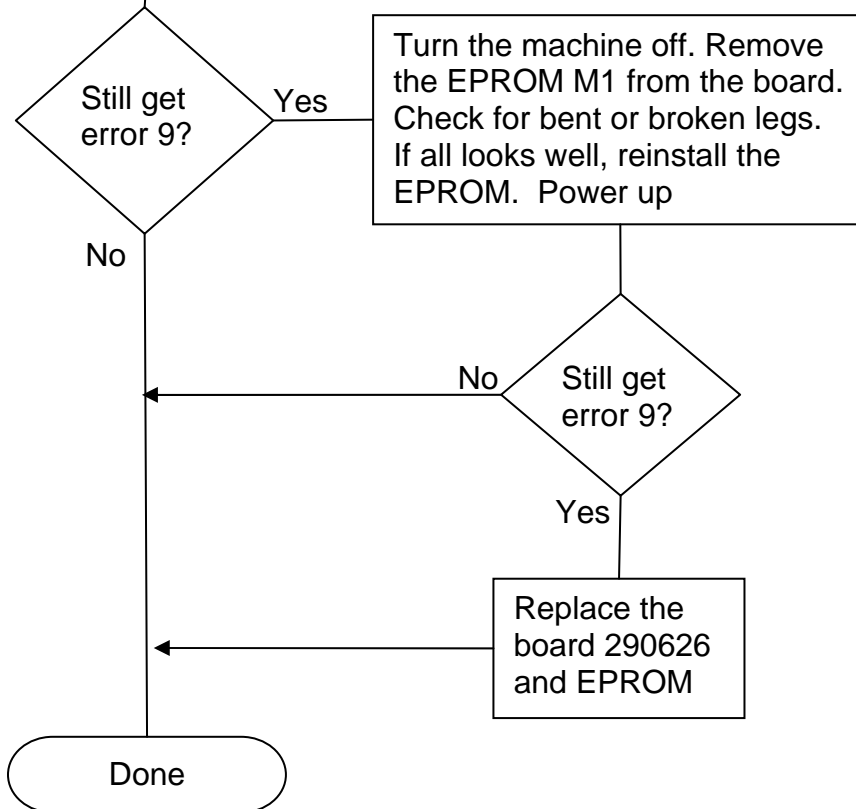

GDF28 Dispenser

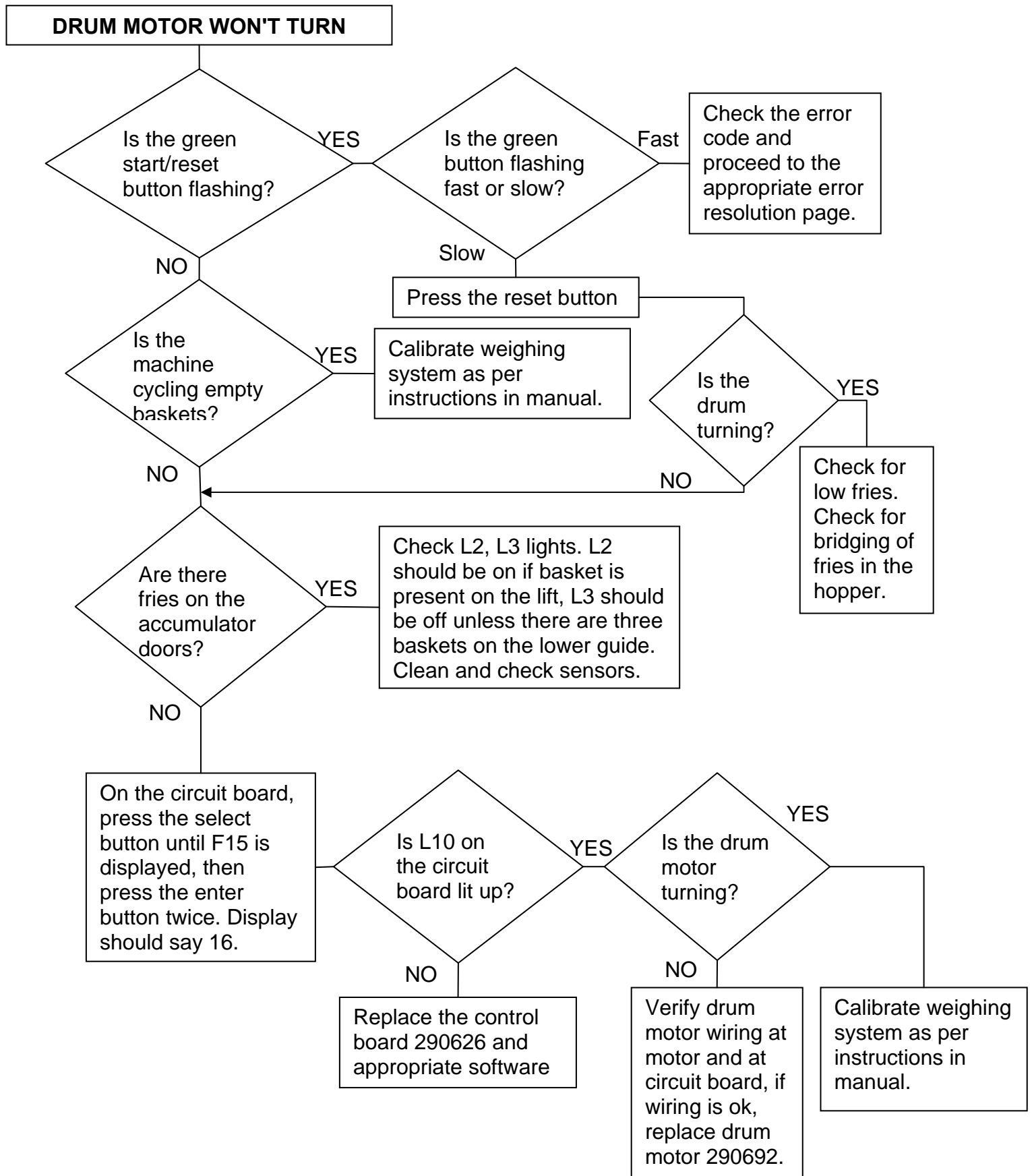

GDF28 Dispenser

TROUBLESHOOTING

In the following charts, the PROBLEM columns contain a list of problems that may occur, the PROBABLE CAUSE column describes why the problem may have appeared; and the CORRECTIVE ACTION column describes the action that must be taken to eliminate the problem. If, after performing the procedure listed under CORRECTIVE ACTION, you have not corrected the problem, call our Service Department for assistance (see page 5).

NOTE: Press the Start/Reset Button after correcting the problem.

| PROBLEM | PROBABLE CAUSE | CORRECTIVE ACTION |
|--|---|--|
| Start/Reset Button is flashing slowly (about once per second) and Lift remains up. | Hopper is empty | Fill the Hopper with french fries. |
| | Frozen fries in the hopper have formed a "bridge" over the Drum. | Remove the Hopper Lid and re-distribute the fries inside. Press the Start/Reset button. The Drum will begin rotating in a few seconds. |
| | Hopper Drum is not locked onto the shaft. | Install the Hopper Assembly correctly. |
| | Drum is damaged. | Replace Drum. |
| Basket Loads are consistently light or heavy. | Diverter not installed. | Verify diverter is installed correctly. |
| | The Hopper is touching the Accumulator Doors. | Re-assemble the Hopper. No objects, other than french fries, may touch the Accumulator Doors. |
| | Basket Load targets were not set properly. | Verify proper target values. Adjust if necessary (refer to Functions 6-9, 21 & 22, beginning on on page 13). |
| | The Weight Sensor has malfunctioned. | Verify Weight Sensor tare and calibration. (See page Error! Bookmark not defined. for calibration procedures.) |
| Dispenser Drum is not rotating. | The Hopper Accumulator is full. | The Dispenser Drum will rotate only when the Hopper Accumulator requires more fries. |
| | Hopper is empty (Start/Reset Button is flashing slowly). | Fill the Hopper with fries and press the Start/Reset button. The Drum will begin rotating in a few seconds. |
| | Fries have formed a "bridge" over the Drum (Start/Reset Button is flashing slowly). | Remove the Hopper Lid and re-distribute the fries inside. Press the Start/Reset button. The Drum will begin rotating in a few seconds. |
| | The Dispenser has detected a SYSTEM FAULT (Start/Reset Button is flashing rapidly). | Continue troubleshooting. If the Accumulator needs more fries, the Dispenser Drum will continue rotating when the Start/Reset Button is pressed. |
| | Hopper Drum is not locked onto the shaft. | Install the Hopper Assembly correctly. |
| | The Hopper is touching the Accumulator Doors. | Re-assemble the Hopper. No objects, other than fries, may touch the Accumulator Doors. |
| | The Diverter fell inside the Hopper preventing the Dispenser Drum from turning. | Remove the Diverter from inside the Hopper and install correctly. |
| | Basket Load targets were not set properly. | Verify proper target values. Adjust if necessary (refer to Functions 6-9, 21 & 22, beginning on on page 13). |
| | The Weight Sensor has malfunctioned. | Perform a Weight Sensor calibration procedure. (See page Error! Bookmark not defined..) |
| | Drum is damaged. | Replace Drum. |
| Baskets are sticking or tipping on Upper or Lower Guide | Fries, crumbs, or shortening have accumulated on the Guide or Lift Saddle. | Turn the Power Switch off, and clean the Guide and Lift Saddle with a hot towel. |
| | A Basket is bent or damaged. | Replace the damaged Basket. |
| | The Lift Saddle is assembled incorrectly or damaged. | Re-assemble, repair or replace the Lift Saddle. Check that shoulder screws are not loose, bent, or missing (See page 28). |
| | The guide is not assembled correctly. | Re-assemble the guide |
| | Incorrect Basket. | Use the Custom Fry Baskets supplied with the Dispenser. |
| | Lift height improperly adjusted. | Adjust the Lift height (Functions 30 and 31, see page Error! Bookmark not defined.). |
| The Guide is bent or the Basket Slides are damaged. | Repair or replace the components. | |

GDF28 Dispenser

NOTE: Press the Start/Reset Button after correcting the fault condition.

| PROBLEM | PROBABLE CAUSE | CORRECTIVE ACTION |
|---|--|---|
| Accumulator Doors do not close | Accumulator Motor failure | Observe L11 on the Controller Board, when it is ON the motor should turn. Check for broken or loose wiring to the motor. |
| | Accumulator Home Switch failure | When the Accumulator cycles, L7 on the Controller Board should blink. If not, check for loose or broken wires for the Accumulator. Verify that the switch functions by manually activating it. |
| | The Accumulator Door linkage is loose or binding, or the linkage spring is disconnected or broken. | Examine the linkages for loose or broken components. Lubricate Accumulator Door pivot points. |
| Basket Stop-gate does not hold Baskets in place | Stopgate Motor failure | Observe L22 and L23 on the Controller Board (L13 on Controller 290322). When either is ON the motor should turn. Check for broken or loose wiring to the motor. |
| | Encoder failure | When the Stopgate cycles, L6 on the Controller Board should blink. If not, check for loose or broken wires for the Stopgate. |
| | Hard Stop broken | If Stopgate can be rotated all the way around, the Hard Stop needs to be replaced. |
| Does not dispense fries into a waiting Basket. | The Lift Saddle is assembled incorrectly or damaged. | Re-assemble, repair or replace the Lift Saddle. |
| | A Basket is positioned incorrectly on the Lift Saddle. | Reposition the Basket in the Lift Saddle. |
| | Lift height improperly adjusted. | Adjust the Lift height (Functions 30 and 31, see page Error! Bookmark not defined.). |
| | Lift Sensor is not working. | Verify by observing L2 on Controller Board. (See pages 29 & 30.) |
| SYSTEM ERROR: (Start/Reset Button flashes rapidly as Lift reaches top or bottom) | Lift Motion fault. | An Error #2 may have occurred. Pressing the Start/Reset Button will clear this error. If problem persists, there may be a problem with the Lift mechanism or electronics. |
| | A tipped Basket stopped the Basket Lift. | Remove the Basket. Check it to be sure that it is not bent or damaged. Clear the Lift Saddle of any fries or shortening. Press the Start/Reset button. If problem re-occurs, remove and re-assemble the guides. |
| | Lift Sensor or Guide Sensor is not functioning properly. | Clean the sensors with a HOT wet towel. Press the Start/Reset button. Verify proper sensor operation. |
| | Lift Mechanism Failure | Verify by manually cycling the Lift with Function #12. (Refer to Function 12, page 14.) |
| | A system Error has occurred. | Check the controller board service interface for an error code. (See page 16 for a description of all the error codes.) |
| | Lift Position Encoder Error | Verify encoder operations, (<i>on the controller board, observe L4 and L5 pulsing as the Lift moves</i>) repair or replace the encoder that does not function. |
| Dispenses fries with no basket present | Shortening on Sensor | Power off, clean sensor with hot wet towel. |
| | Sensor too sensitive | Adjust sensor. (See page 28.) |

GDF28 Dispenser

ADJUSTMENTS AND DIAGNOSTICS

For optimum performance, the weighing system should be calibrated twice per year. To do this, follow these steps:

NON-CONTACT WEIGHING SYSTEM (NCWS) CALIBRATION

1. Remove the BACK PANEL of the Dispenser.
2. Turn the Power Switch to the ON position.
3. Select Function 30. Record the lift height setting.
4. Select Function 17. Press the ENTER button.
5. Select Function 3 on the controller and press the ENTER button to disable the weighing.
6. Run a Basket through the Dispenser to empty the Accumulator Doors.
7. Remove the Hopper from the Dispenser.
8. Verify that the Accumulator Doors are empty.
9. For International units, select Function 25 and press the ENTER button. Press ENTER again to change from "US" to "In". Press Select to exit the function.
10. Select Function 5 (Calibrate) on the controller and press the ENTER button. The word "CAL" will appear on the display.
11. Wait 10 seconds, and press the ENTER button: the display will respond "C1.0".
12. Place 1.0 lb. (450 gm) on the Accumulator Doors (use a 1 lb. reference weight), wait 10 seconds, and press the ENTER button: the display will respond "C2.0".
13. Place 2.0 lbs. (900 gm) (an additional 1.0 lb. (450 gm)) on the Accumulator Doors. Wait 10 seconds and press the ENTER button: the display will respond "---".
14. Select Function 11 and press the ENTER button. With 2 lb. (900 gm) on the Accumulator Doors the readout should be approximately 230 (+/-9). Remove 1 lb. (450 gm) from the Accumulator doors. The readout should be approximately 130 (+/-9). Remove all weight from the Accumulator doors. The readout should be 30 (+/-9).
15. Turn the Dispenser off, wait 15 seconds, turn the Dispenser on. The new calibration will now be active.
16. Reinstall the Hopper on the Dispenser.
17. Reset the Lift height using either Function 30 (lower lift) or 31 (raise lift) to input the setting recorded in step 3. The default is 102.
18. Cycle baskets through the Dispenser. Check basket loads and adjust if necessary.
19. Replace the Back Panel.

SERVICE NOTE:
Calibration must be performed any time a controller pcb, e-prom, or NCWS component is replaced.

GDF28 Dispenser

LIFT DRIVE ASSEMBLY INFORMATION

The bottom of the Lift Cylinder stroke is home by definition. This is found at power up and set to 77. This is an arbitrary number, mathematically chosen for maximum flexibility in the Lift control. The default stroke is 102 counts, and is adjustable. There are 12 counts per inch and full stroke is 8.5 inches ($12 * 8.5 = 102$, $102 + 77 = 179$). There is approximately 1/4 inch between top of stroke and hard stop. The dispenser logic controls the Lift to the specified location. If adjusted to the hard stop (approximately 105), it will still function. Adjusting it past the hard stop will result in an endless chain of Error #2's, and may result in permanent damage to controllers and lift drive motor.

CHECK/ADJUST SENSOR RANGES

1. Remove all baskets on the dispenser.
2. Select Function 12 on the controller board (see pages 12 & 14) and press ENTER to lower the Lift Saddle. This will prevent the Accumulator Doors from accidentally opening.
3. Verify that the indicator lights for the Basket Sensors are OFF (Lights L2 and L3). See the CONTROLLER BOARD illustrations on pages 29 and 30.
4. Place your hand directly in front of the Basket Sensor. Verify that indicator light L2 turns ON. Move your hand away from the sensor until the light turns OFF.
5. Place the palm of your hand in front of the sensor. The indicator light should stay on until your hand is 4-6 inches (10-15 cm) away from the sensor. If this range is incorrect, adjust the GAIN control on the rear of the sensor.
6. Repeat steps 3 through 6 for the Guide Sensor. The guide sensor lights indicator light L3.
7. Select Function 18 and press ENTER to clear the error log.
8. Turn the power switch OFF.
9. Replace the BACK PANEL.
10. Finish reassembling the dispenser.

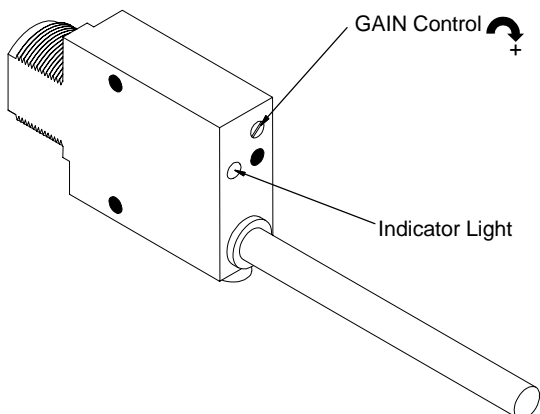

CHECK SADDLE FOR DAMAGE

Inspect the four Shoulder Screws for being bent or loose. Measure the Saddle at each Skid Plate position to determine if the Saddle frame is damaged. Measure as shown by the dashed line in the illustration below. Saddle frame should measure $11 \frac{5}{8}'' \pm 1/16''$ (295.3mm \pm 2mm).

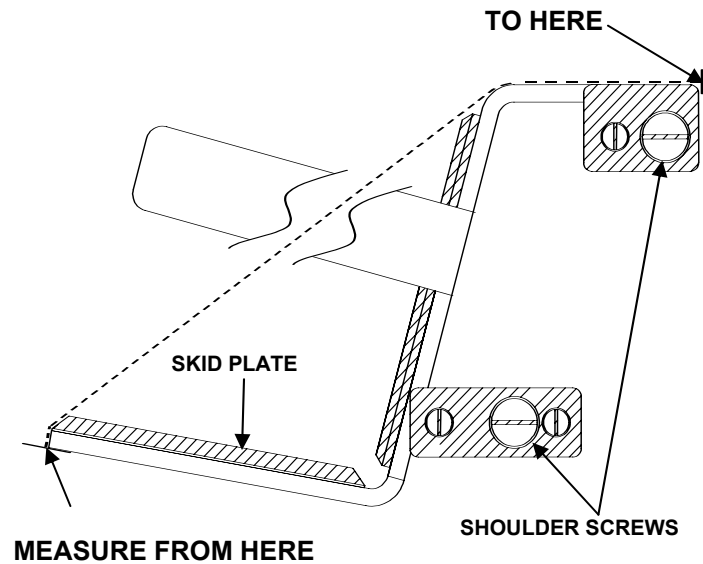

GDF28 Dispenser

CONTROLLER BOARD LAYOUT

Plus Controller PCB (P/N 290626)

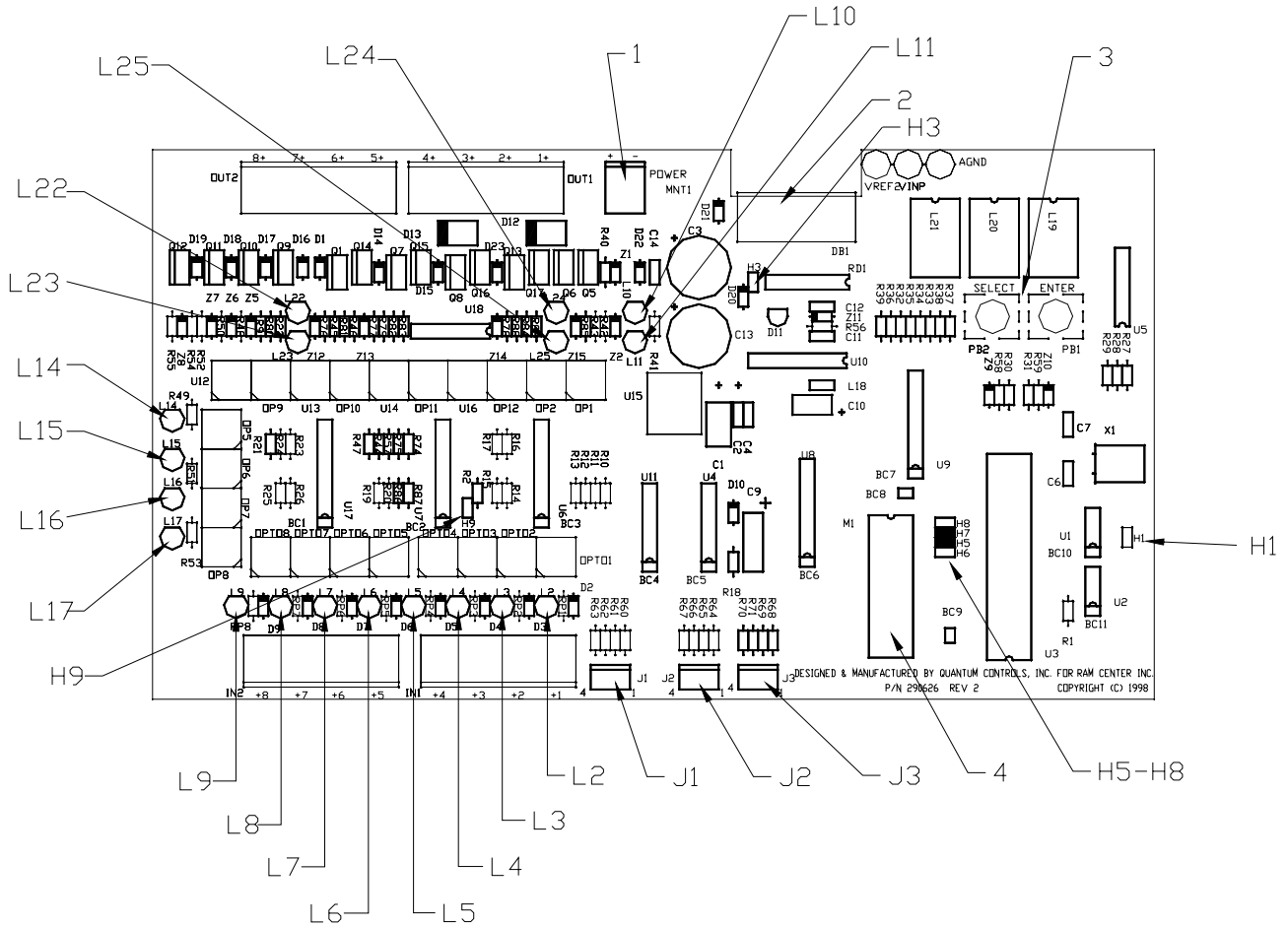

| ITEM | DESCRIPTION | ITEM | DESCRIPTION | ITEM | DESCRIPTION |
|-------|--|------|--|------|--------------------------------|
| 1 | Power Input 24 VDC | L2 | Lift optical sensor | L11 | Accumulator Door Drive |
| 2 | Weight Sensor Connection | L3 | Guide optical sensor | L14 | Reverse |
| 3 | Function Buttons | L4 | Lift encoder 2 (J3) | L15 | Start light |
| H5-H8 | EPROM Configuration | L5 | Lift encoder 1 (J1) | L16 | Load switch multiplexer |
| 4 | Software EPROM 290786 | L6 | Stopgate home switch (J2) | L17 | Start/Reset switch multiplexer |
| J3 | Lift encoder phase 2 connection (L4) Green | L7 | Accumulator home switch | L22 | Close stopgate |
| J2 | Stopgate sensor connection (L6) Yellow | L8 | Selector switch position 3 | L23 | Open stopgate |
| J1 | Lift encoder phase 1 connection (L5) Blue | L9 | Selector switch position 2 Start/Reset Input | L24 | Lift down |
| H9 | Electric mode jumper | L10 | Rotate Drum | L25 | Lift up |

| Jumper Settings for Plus Controller Board | | | | | | |
|---|----|----|----|----|----|----|
| H1 | H3 | H5 | H6 | H7 | H8 | H9 |
| | | X | | X | | X |

GDF28 Dispenser

Controller Board (P/N 290322) Obsolete

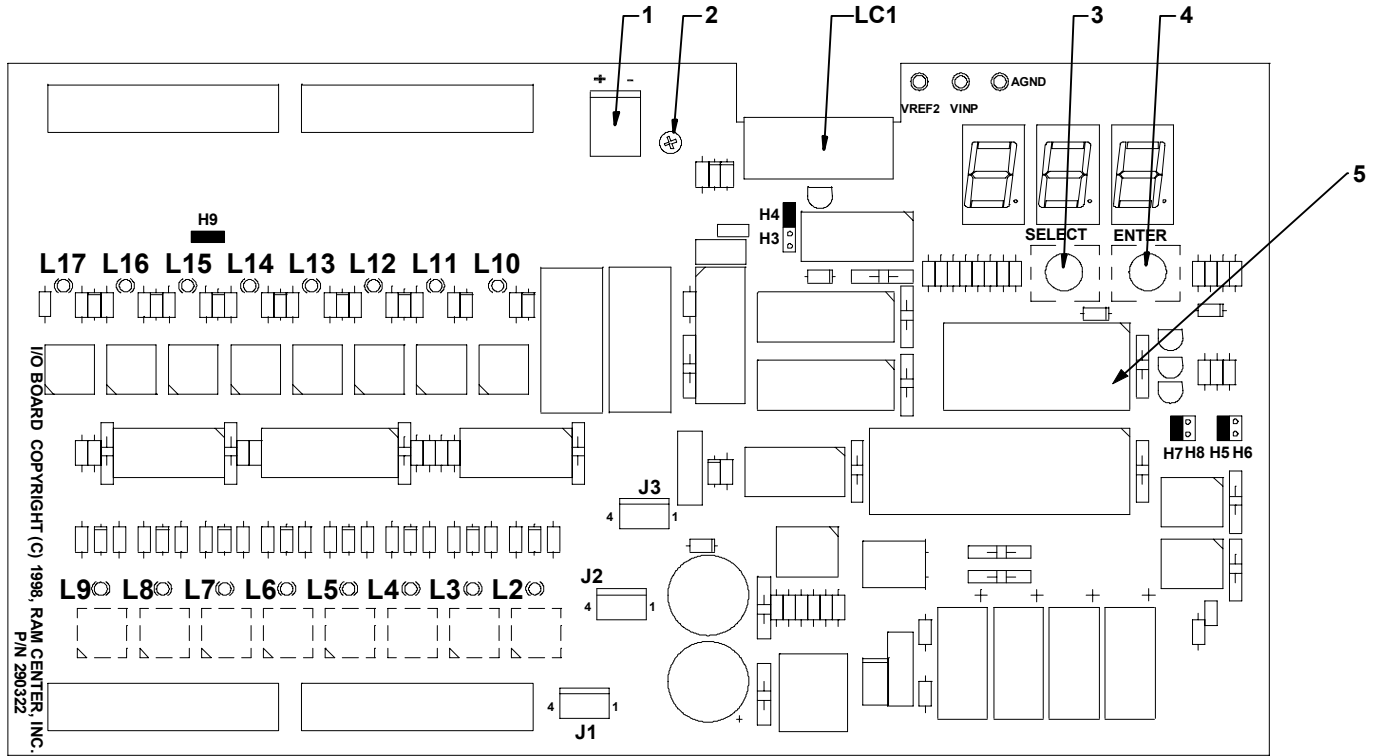

INPUT CONNECTORS AND LED FUNCTIONS

| ITEM | DESCRIPTION | ITEM | DESCRIPTION | ITEM | DESCRIPTION |
|------|-----------------------------------|-------|--|------|----------------------|
| 1 | Power Input 24 VDC | L2 | Lift Optical Sensor | L10 | Rotate Drum |
| 2 | Grounding Screw | L3 | Guide Optical Sensor | L11 | Accumulator Drive |
| 3 | Select Button | L4 | Lift Encoder – 2 (J3) | L12 | Lift Drive |
| 4 | Enter Button | L5 | Lift Encoder – 1 (J1) | L13 | Stopgate Drive |
| 5 | E-PROM N/A | L6 | Stopgate Home Switch | L14 | Reverse |
| LC1 | Weight Sensor Connector | L7 | Accumulator Home Switch | L15 | Start Light |
| J1 | Lift Connector – 1 (L5) Blue | L8 | Select Sw. Pos. 3 | L16 | Load Sw. Mpx. |
| J2 | Stopgate Connector (L6) Yellow | L9 | Select Sw. Pos. 2 Start/Reset Input | L17 | Start/Reset Sw. Mpx. |
| J3 | Lift Connector – 2 (L4) Green | L8&L9 | Both OFF = Sw. Pos. 1 | | |

Jumper Settings for Plus Controller Board

| H1 | H4 | H5 | H6 | H7 | H8 | H9 |
|----|----|----|----|----|----|----|
| | X | X | | X | | X |

GDF28 Dispenser

GDF28 SCHEMATIC Inductive Encoders

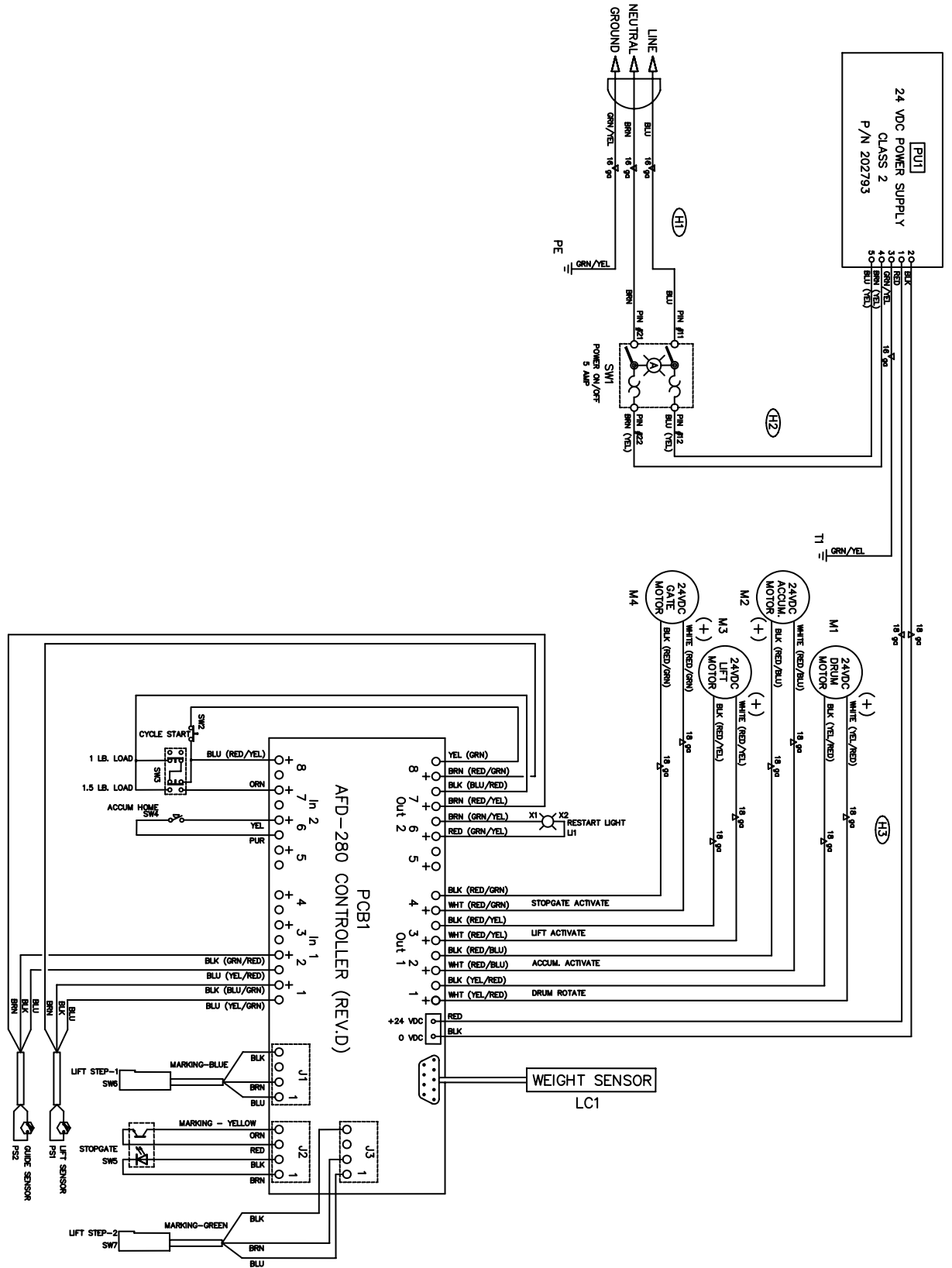

GDF28 Dispenser

GDF28 SCHEMATIC Optical Encoder

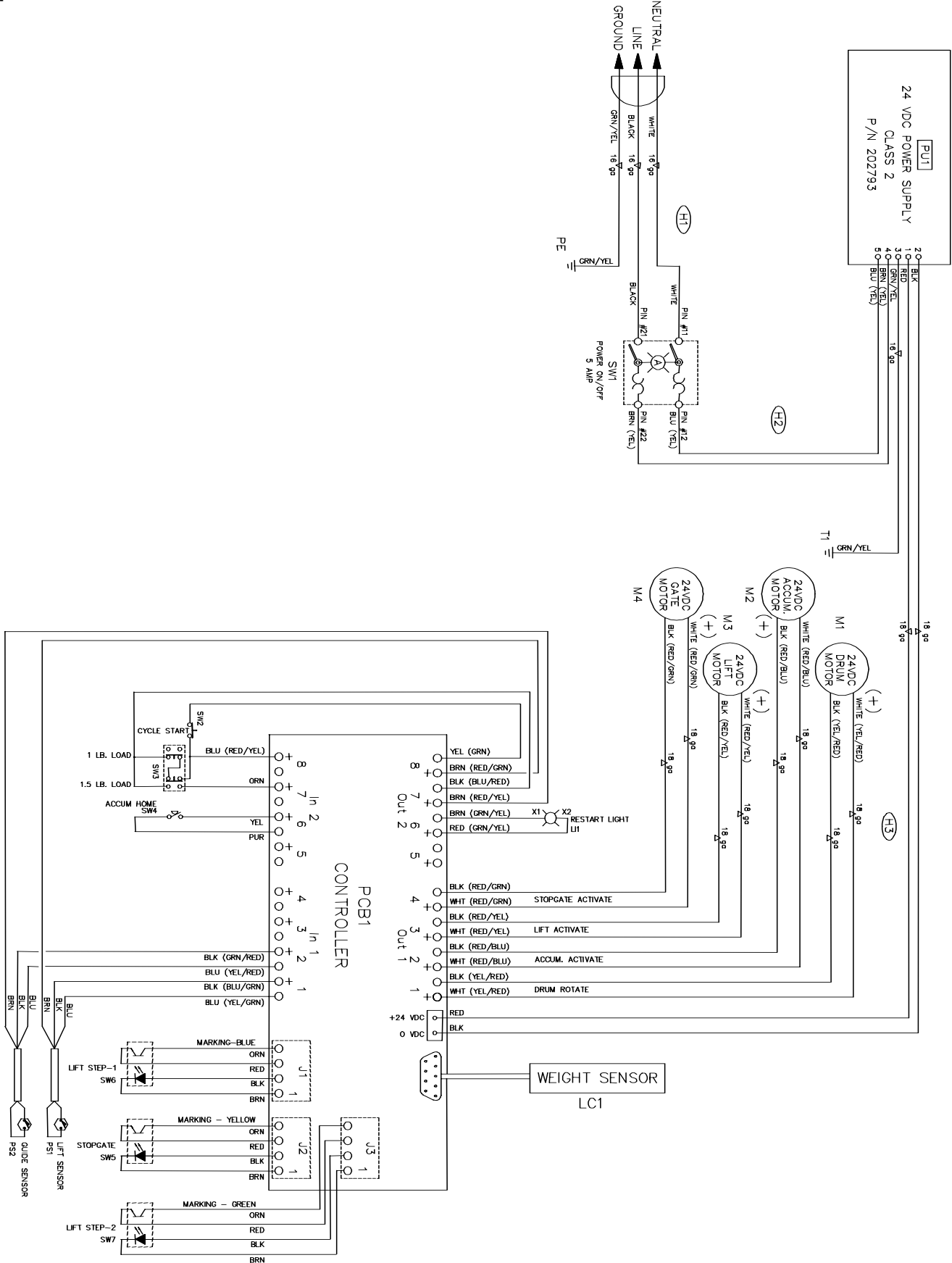

GDF28 Dispenser

PART IDENTIFICATION

FRONT VIEW

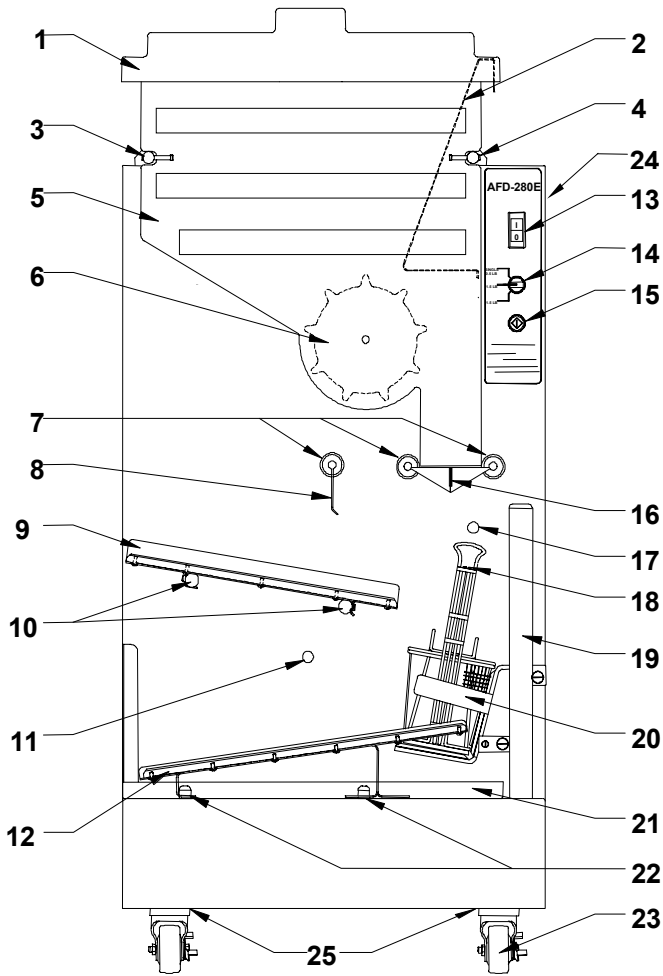

LOWER SIDE VIEW

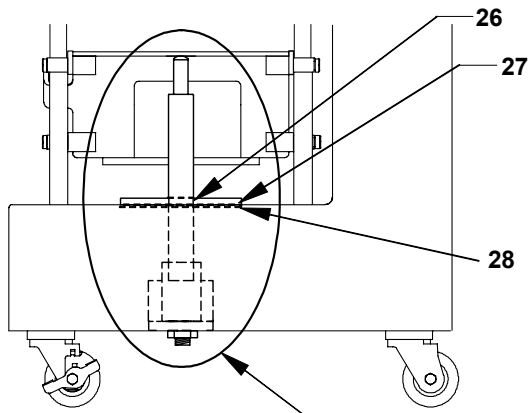

BASKET LIFT ASSEMBLY
See pages 37 & 38

| Item | Description | Part No. | Qty |
|------|---|------------------|--------|
| 1 | Hopper Lid | 202364 | 1 |
| 2 | Diverter | 219129 | 1 |
| 3 | Hopper Support Bar, Left | 202884 | 1 |
| 4 | Hopper Support Bar, Right | 202885 | 1 |
| 5 | Hopper | 202368 | 1 |
| 6 | Dispenser Drum | 202366 | 1 |
| | Shaft Collar | 203240 | 1 |
| 7 | Shaft Collars | 203256 | 3 |
| 8 | Stopgate Shaft | 290384 | 1 |
| 9 | Upper Guide (complete) | 202219 | 1 |
| | Guide Slides | 202359 | 2 |
| | Guide Slide Screws | 290000 | 10 |
| 10 | Support Bars (Upper Guide) | 202218 | 2 |
| | Fillister Screw | 202044 | 2 |
| 11 | Basket Sensor (Lower Guide) | 202038 | 1 |
| | Sensor Window Kit (Includes two windows) | 202619 | 1 |
| 12 | Lower Guide (complete) | 202779 | 1 |
| | Guide Slides | 220494 | 2 |
| | Guide Slide Screws | 290000 | 12 |
| 13 | Power Switch | 202381 | 1 |
| 14 | Selector Switch | 215607 | 1 |
| 15 | Start/Reset Switch | 215606 | 1 |
| | Start/Reset Lamp Lens only | 216489 290771 | 1 1 |
| 16 | Accumulator Doors | | |
| | Left | 203254 | 1 |
| | Right | 203253 | 1 |
| 17 | Basket Sensor (Basket Lift) | 202038 | 1 |
| | Sensor Window Kit (Includes two windows) | 202619 | 1 |
| 18 | Basket | 216258 | 10 |
| 19 | Lift Guide Post | 220456 | 2 |
| | Lift Saddle Assembly | 202782 | 1 |
| | Roller | 217810 | 1 |
| 20 | Shoulder Screw | 202064 | 4 |
| | Saddle Skid | 202762 | 2 |
| | Splash Shield | 220473 | 4 |
| 21 | Drip Pan | 202780 | 1 |
| 22 | Locator Pins (Lower Guide and Drip Pan) | 290687 290394 | 2 |
| 23 | Front Caster with Brake | 216596 | 2 |
| 24 | Safety Label Set (side of cabinet) | 202986 | 1 |
| 25 | Caster Mounting Screw (quantity is per caster) | 202530 | 4 |
| 26* | O-Ring | 290152 | 1 |
| 27 | Lift Cover | 290432 | 1 |
| 28* | Lift Cover Gasket | 292166 | 1 |

*Items 26 & 28 are available as a kit: Part number 292463

GDF28 Dispenser

REAR VIEW

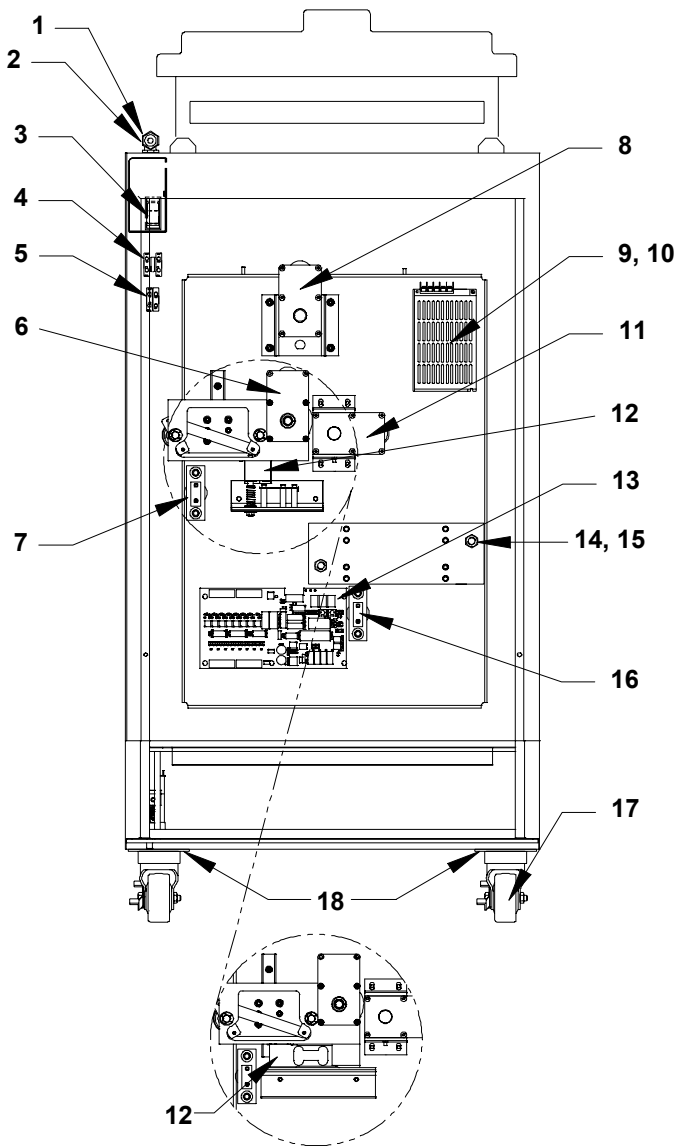



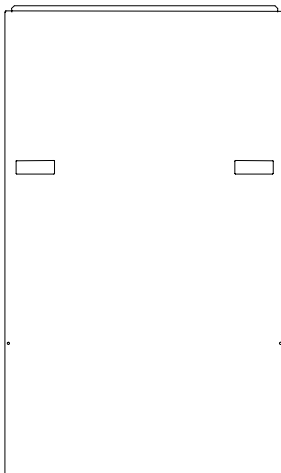

| Item | Description | Part Number | Qty |
|------|--|-------------------------------------|-------------|
| 1 | Power Cord Inlet Domestic Power Cord European Power Cord Australian Power Cord | 202172 202790 202354 | 1 |
| 2 | Cord Relief Elbow Washer Nut | 216692 202586 213942 | 1 1 1 |
| 3 | On/Off Switch | 202381 | 1 |
| 4 | Selector Switch | 215607 | 1 |
| 5 | Start/Reset Switch Start/Reset Lamp Button assembly, including lens | 215606 216489 290771 | 1 1 1 |
| 6 | Accumulator Motor | 290641 | 1 |
| 7 | Basket Sensor (Basket Lift) Sensor Window Kit (Includes two windows) | 202038 202619 | 1 1 |
| 8 | Drum Motor | 292546 | 1 |
| 9 | Power Supply Fuse | 291294 | 1 |
| 10 | Power Supply | 202793 | 1 |
| 11 | Stopgate Motor | 290691 | 1 |
| 12 | Weight Sensor Assembly (NCWS) Refer to page 42 for details | 290724 | 1 1 |
| 13 | Plus Controller Board Software E-PROM (NCWS) [Software E-PROM(Load Cell) [290788] | 290626 290786 [290788] | 1 1 1 |
| 14 | Bolt | 202174 | |
| 15 | Washer | 213264 | |
| 16 | Basket Sensor (Lower Guide) Sensor Window Kit (Includes two windows) | 202038 202619 | 1 1 |
| 17 | Rear Caster | 216595 | 1 |
| 18 | Caster Mounting Screw (quantity is per caster) | 20253 0 | 4 |

Rear Access Door



Rear Access Door hardware

| Item | Description | Part No. | Qty |
|---|---|----------|-----|
|  | U-Clip (mounts on dispenser) | 202892 | 2 |
|  | Retaining Washer (holds 202585 in place) | 202539 | 2 |
|  | Machine screw 10-32 x 1" | 202585 | 2 |
|  | Pocket Pull door handle | 202523 | 2 |
| Pictured at left | Door, stainless steel panel | 202890 | 1 |

GDF28 Dispenser

NEW BACKPANEL CONFIGURATION

| Item | Description | Part Number | Qty |
|------|--|-------------------------|--------|
| 1 | Stopgate Motor (rotated 90°) | 290691 | 1 |
| 2 | Controls Cover | 291507 | 1 |
| 3 | Retainer Clip, Controls Cover | 292559 | 1 |
| 4 | Plus Controller Board Software E-PROM (NCWS) | 290626 290786 | 1 1 |
| 5 | Power Supply Fuse | 291294 | 1 |
| 6 | Power Supply | 202793 | 1 |

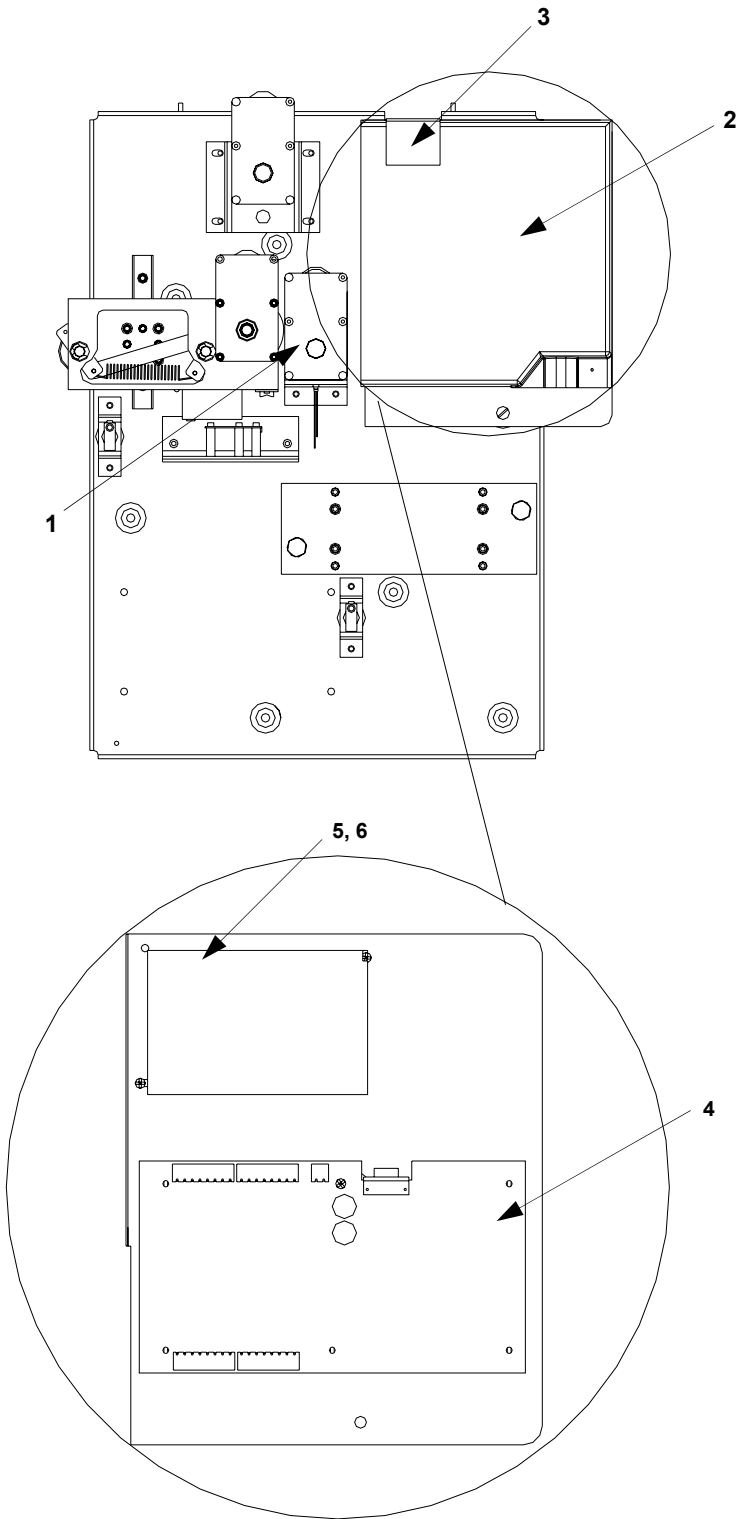

GDF28 Dispenser

BASKET LIFT ASSEMBLY

| Item | Description | Part No. | Qty |
|------|---------------------------------|----------|-----|
| 1 | Lift Motor | 290147 | 1 |
| 2 | Mounting Plate | 290141 | 1 |
| 3 | Encoder Block | 290140 | 1 |
| 4 | Screw, #6-32 UNC | 213507 | 5 |
| 5 | Lock Washer, #6 | 213528 | 1 |
| 6 | Ground Stud (Green Wire) | 290423 | 1 |
| 7 | Nut, #6 | 202874 | 1 |
| 8 | Rubber Washer | 290171 | 1 |
| 9 | Rubber Bushing | 290174 | 1 |
| 10 | Drive Coupler with Encoder Disk | 290292 | 1 |
| | Encoder Disk Only | 290145 | |
| 11 | Lift Motor Wiring Harness | | |
| | White wire on + terminal | 290175 | 1 |
| | Surge suppressor filter, Mov | 290428 | 1 |
| 12 | Encoder Phase 1 | 290690 | 1 |
| | J1 Blue | | |
| 13 | Encoder Phase 2 | 290690 | 1 |
| | J3 Green | | |
| 14 | Screw, #4-40UNC | 290372 | 4 |
| 15 | Lift Lock Bracket | 290146 | 1 |
| 16 | Screw, 1/4-20UNC | 213143 | 1 |
| 17 | Lock Washer, 1/4" | 213142 | 1 |
| 18 | Flange Nut, 3/8-16 UNC | 290394 | 1 |
| 19 | Flat Washer, 3/8" | 202992 | 1 |
| 20 | Lift Tube | 290115 | 1 |
| 21 | Finishing Plug (White) | 290160 | 1 |

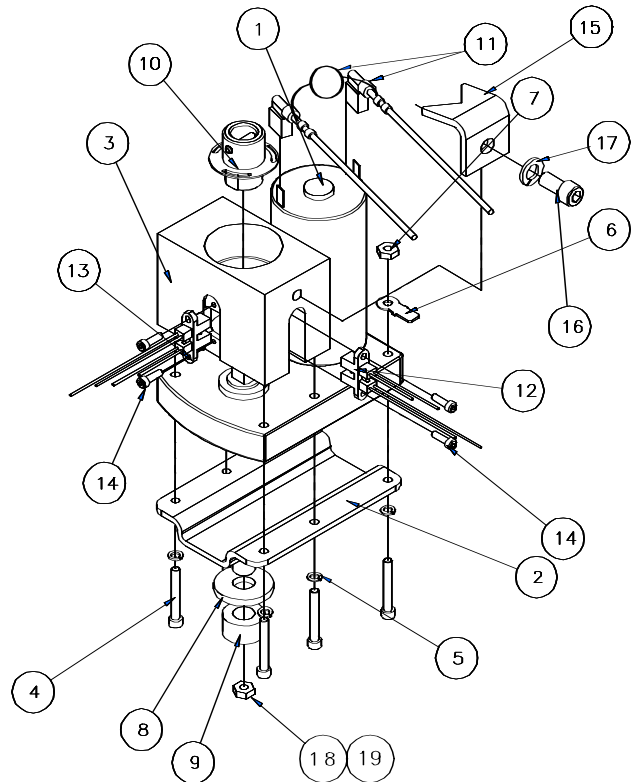
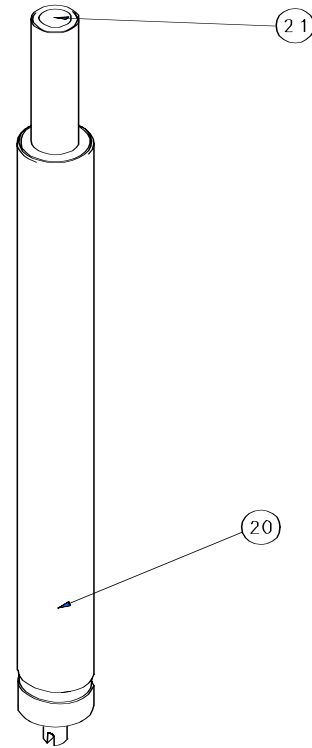

GDF28 Dispenser

NEW BASKET LIFT ASSEMBLY

| Item | Description | Part Number | Qty |
|------|---|-------------|-----|
| 1 | Lift Motor | 290147 | 1 |
| 2 | Mounting Plate | 290141 | 1 |
| 3 | Encoder Block (Black) | 292155 | 1 |
| 4 | Screw #6-32UNC | 290612 | 5 |
| 5 | Lock Washer #6 | 213528 | 5 |
| 6 | Ground Stud (Green Wire) | 290423 | 1 |
| 7 | Nut #6-32UNC | 202874 | 1 |
| 8 | Rubber Washer | 290171 | 1 |
| 9 | Rubber Bushing | 292197 | 1 |
| 10 | Encoder Vane | 292157 | 1 |
| 11 | 4-40 X 1/2 Screw | 292165 | 2 |
| 12 | Lift Lock Bracket | 290146 | 1 |
| 13 | Screw 1/4-20UNC | 213143 | 1 |
| 14 | Lock Washer 1/4" | 213142 | 1 |
| 15 | .38 ID X .063 THK Nylon Washer | 292158 | 1 |
| 16 | Drive Coupler | 292156 | 1 |
| 17 | Inductive Encoders (J1 Blue) (J3 Green) | 292560 | 2 |
| 18 | Flange Nut 3/8-16UNC | 290394 | 1 |
| 19 | Lift Tube (upgrade version) | 292349 | 1 |
| 20 | Finishing Plug (upgrade version) | 292159 | 1 |
| 21 | Lift Cover Gasket Kit (includes o-ring) | 292463 | 1 |
| 22 | Lift Cover (includes o-ring) | 290432 | 1 |
| 23 | O-Ring | 290152 | 1 |
| 24 | Washer 1/4-20UNC | 213141 | 2 |
| 25 | Nut 1/4-20UNC | 213260 | 2 |

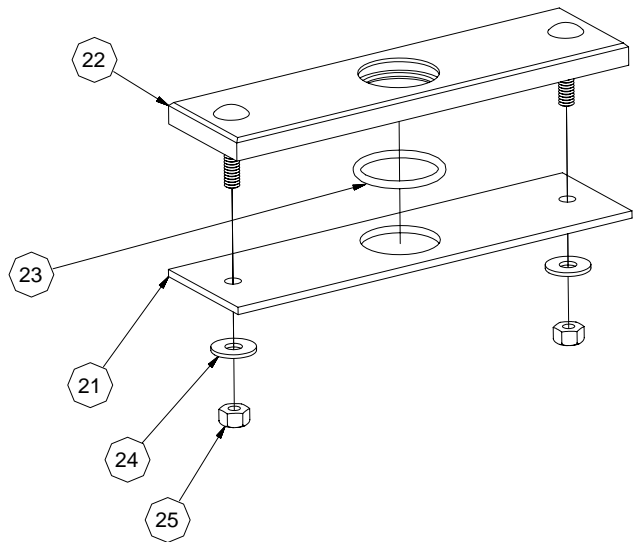
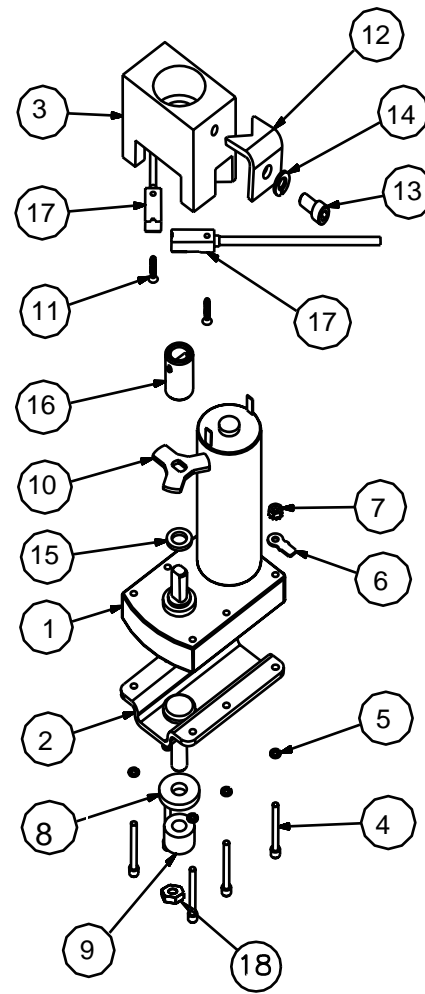
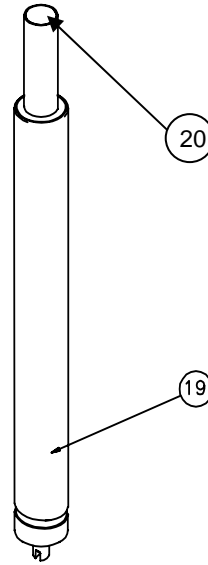

GDF28 Dispenser

STOPGATE DRIVE ASSEMBLY

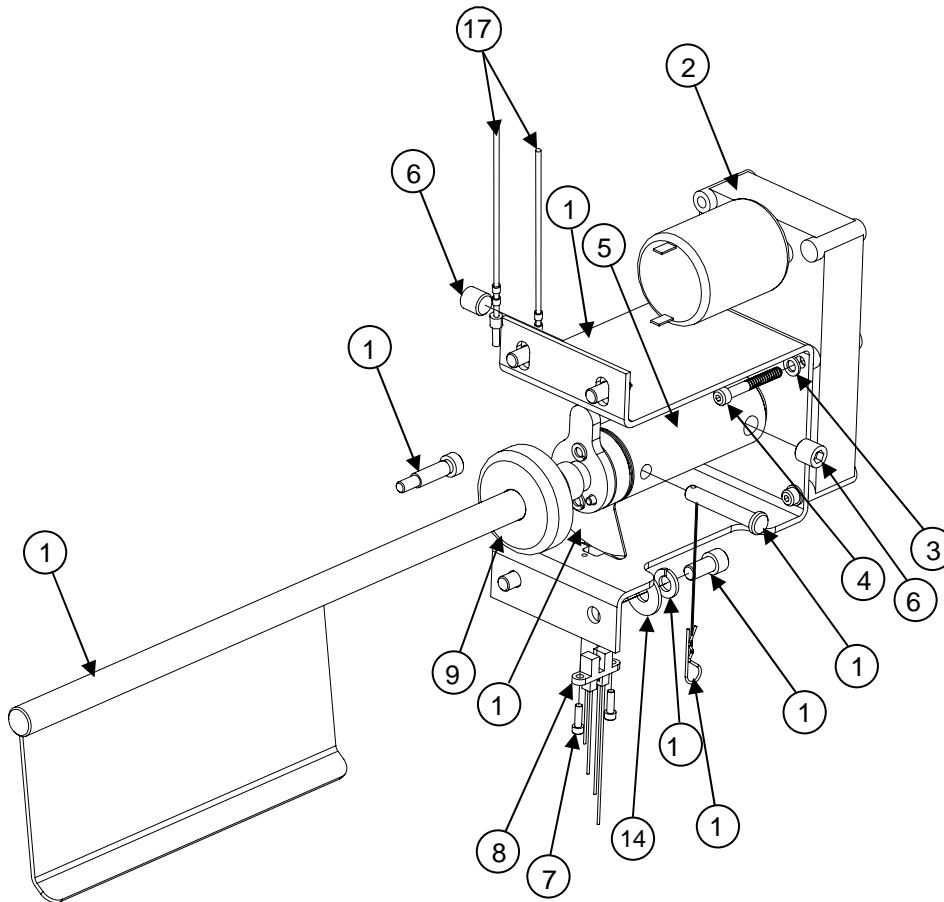

| ITEM | QTY | PART NO. | DESCRIPTION |
|------|-----|----------|---|
| 1 | 1 | 290126 | Housing, Stopgate |
| 2 | 1 | 290691 | 24VDC Gearmotor, Stopgate |
| 3 | 4 | 213140 | Washer, Lock #10 |
| 4 | 4 | 213136 | Screw, Socket head, #10-32 X 1-1/4" |
| 5 | 1 | 290379 | Stopgate Tube Assembly |
| | 1 | 290137 | Encoder Vane only |
| 6 | 2 | 290653 | Set Screw, 3/8"-24 UNC |
| 7 | 2 | 290372 | Nylon Socket Head Cap Screw, #4-40 UNC X 1/4" |
| 8 | 1 | 290690 | Encoder (includes item #7) |
| 9 | 1 | 203256 | Stopgate Shaft Collar |
| 10 | 1 | 290384 | Stopgate Shaft |
| 11 | 1 | 290127 | Clevis Pin |
| 12 | 1 | 202081 | Hairpin Clip |
| 13 | 1 | 203258 | Hardstop, for units prior to serial #AFER0012C 01768, 1/4" Dia X 3/4" (attaches to backplane) |
| | | 291276 | Hardstop, for units after and including serial #AFER0012C 01768, 5/16" Dia X 3/4" (attaches to backplane) |
| 14 | 4 | 213141 | Washer, Flat, 1/4" |
| 15 | 4 | 213142 | Washer, Lock, 1/4" |
| 16 | 4 | 213143 | Screw, Socket head, 1/4-20 x 1/2 |
| 17 | 1 | 290124 | Harness, Distribution, 24VDC, 30" |
| 18 | 1 | 290137 | Vane, Stopgate |

GDF28 Dispenser

ACCUMULATOR ASSEMBLY

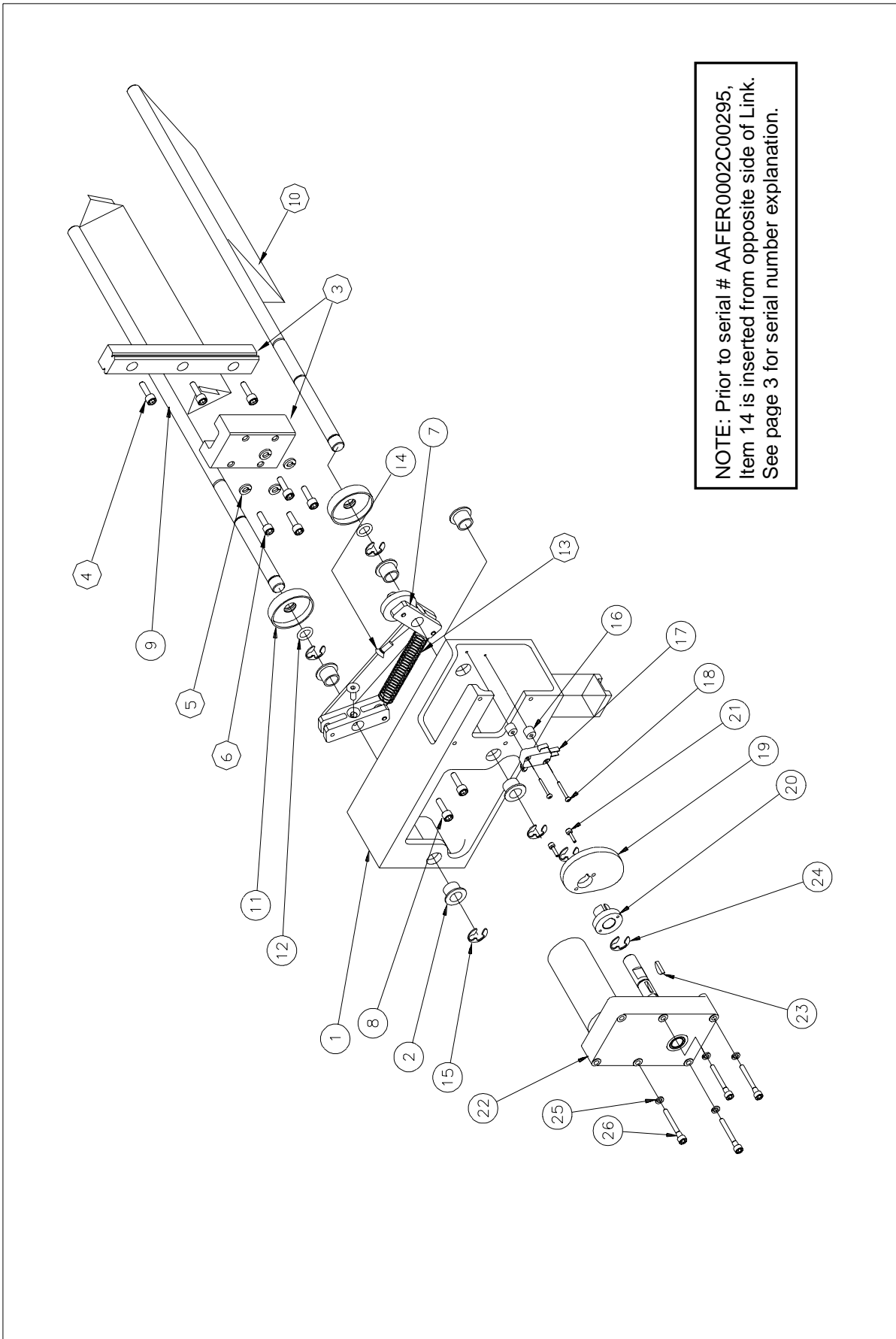

NOTE: Prior to serial # AAFER0002C00295,
Item 14 is inserted from opposite side of Link.
See page 3 for serial number explanation.

GDF28 Dispenser

| ITEM | QTY | PART NUMBER | DESCRIPTION |
|-----------|-----|-------------|--|
| 1 | 1 | 203245 | Extrusion, Accumulator Housing |
| 2 | 5 | 202974 | Bearing, Flange, 1/2 In. I.D. x 5/8 In. O.D. |
| 3 | 1 | 202068 | Assembly, Linear Bearing |
| 4 | 3 | 202073 | Screw, Socket Head Cap, 1/4-20 x 3/4: |
| 5 | 4 | 213142 | Washer, Lock, 1/4" |
| 6 | 4 | 203097 | Screw, Socket Head Cap, M6 x 16mm |
| 7 | 1 | 203374 | Assembly, Linkage, Accumulator |
| | 2 | 203219 | Link, Accumulator Doors |
| | 1 | 203220 | Rod, Connecting |
| | 1 | 203221 | Wheel, Cam Follower |
| | 4 | 203258 | Screw, Shoulder, Socket Head Cap 1/4"x3/4" |
| | 4 | 203259 | Bearing, Plastic, 1/4" I.D. x 5/16" O.D. x 1/4" |
| | 1 | 203260 | Spring, Ext., .650" x 3.271 |
| 8 | 1 | 202073 | Screw, Socket Head Cap, 1/4-20 UNC x 3/4 In., Zinc Plated |
| 9 | 1 | 203253 | Accumulator Door, Right |
| 10 | 1 | 203254 | Accumulator Door, Left |
| 11 | 2 | 203256 | Shaft Collar, 1/2 In. I.D. |
| 12 | 2 | 203257 | Gasket, O-Ring, 11/16 In. O.D. x 1/2 In. I.D. x 3/32 In. Thick |
| 13 | 1 | 203260 | Spring |
| 14 | 2 | 213549 | Screw, Flat head Cap, 1/4-20 UNC x 5/8 In., Zinc Plated |
| 15 | 4 | 213356 | Retaining Ring, E-Clip, 1/2 In. |
| 16 | 2 | 203250 | Stand-off, 3/8 O.D. x 0.140 I.D. x 5/16 long, Nylon |
| 17 | 1 | 203249 | Switch, Microswitch with roller |
| 18 | 2 | 213500 | Screw, Pan Head Machine, 4-40 UNC x 7/8 In., Phillips, Zinc Plated |
| 19 | 1 | 203222 | Cam, Accumulator |
| 20 | 1 | 203248 | Hub, Cam, Accumulator |
| 21 | 2 | 213144 | Screw, Socket Head Cap, 6-32 UNC x 1/2 In., Zinc Plated |
| 22 | 1 | 290641 | Motor, DC Drive, Accumulator Doors |
| 23 | 1 | 203251 | Key, Woodruff, #405 |
| 24 | 2 | 213356 | Retaining Ring, E-Clip, 1/2 In. |
| 25 | 4 | 213140 | Washer, Lock, #10 |
| 26 | 4 | 213518 | Screw, Socket Head Cap, 10-32 UNF x 1 1/2 In., Zinc Plated |
| Not Shown | 1 | 290354 | Wiring Harness, Accumulator Motor |

GDF28 Dispenser

DRUM MOTOR ASSEMBLY

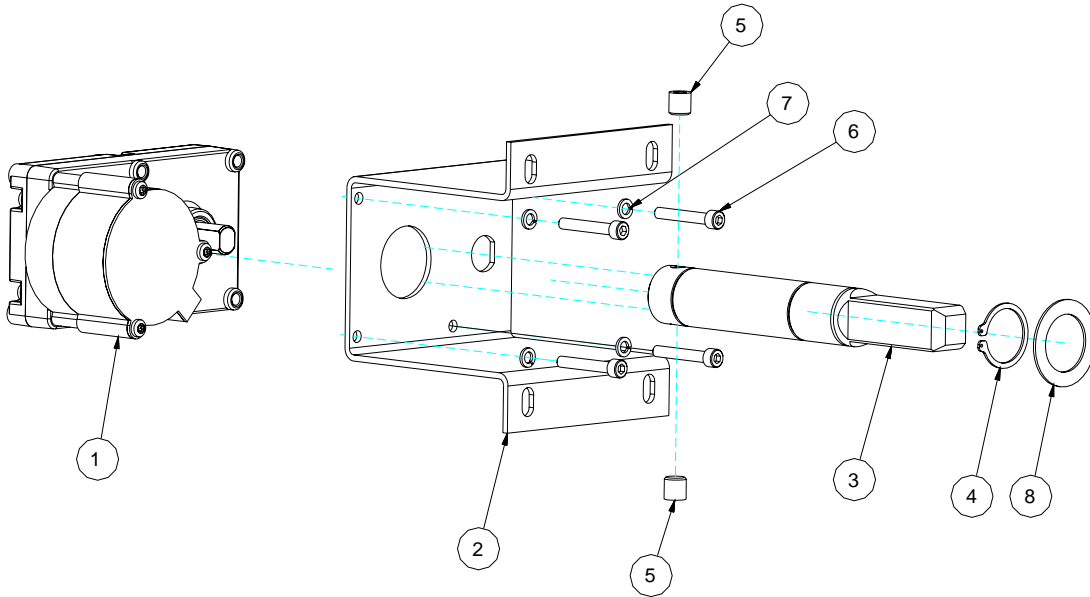

Not Shown, Item 9- Wiring Harness

| ITEM | QTY | PART NUMBER | DESCRIPTION |
|------|-----|-------------|---|
| 1 | 1 | 292546 | Kit, Gear Motor, 24VDC, Drum |
| 2 | 1 | 202797 | Mounting Bracket, Motor |
| 3 | 1 | 203380 | Drum Shaft |
| 4 | 1 | 213911 | Retaining Ring, External, Zinc Plated, 1" |
| 5 | 2 | 290653 | Set Screw, Socket Head, Cup Point, 3/8-24x3/8" |
| 6 | 4 | 213136 | Cap Screw, Socket Head, Zinc Plated, 10-32 x 1 1/4" |
| 7 | 4 | 213140 | Lock Washer, Zinc Plated, #10 |
| 8 | 1 | 202896 | Flat Washer, Zinc Plated 1"x1 1/2" x .047" |
| 9 | 1 | 290124 | Harness, Distribution, 24VDC, 30" |

LIFT SADDLE ASSEMBLY

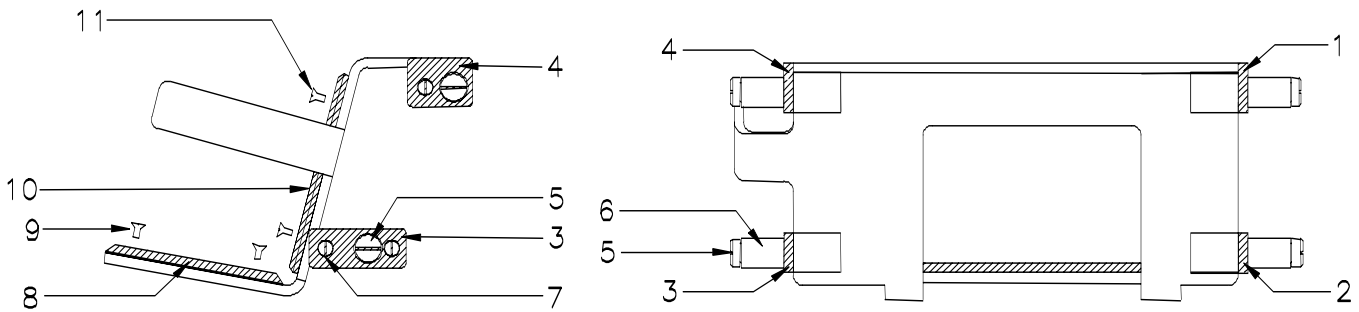

SIDE VIEW

BACK VIEW

| ITEM | QTY | PART NUMBER | DESCRIPTION |
|------|-----|-------------|-------------------------|
| 1 | 1 | 220468 | Wear Strip, Upper Right |
| 2 | 1 | 220469 | Wear Strip, Lower Right |
| 3 | 1 | 220469 | Wear Strip, Lower Left |
| 4 | 1 | 220467 | Wear Strip, Upper Left |
| 5 | 4 | 202064 | Shoulder Screw |
| 6 | 4 | 217810 | Guide Roller |
| 7 | 6 | 202046 | Wear Strip Screws |
| 8 | 2 | 202762 | Saddle Skid |
| 9 | 4 | 202047 | Saddle Skid Screw |
| 10 | 1 | 220473 | Splash Shield |
| 11 | 5 | 202047 | Splash Shield Screw |

GDF28 Dispenser

NON-CONTACT WEIGHING SYSTEM ASSEMBLY (NCWS)

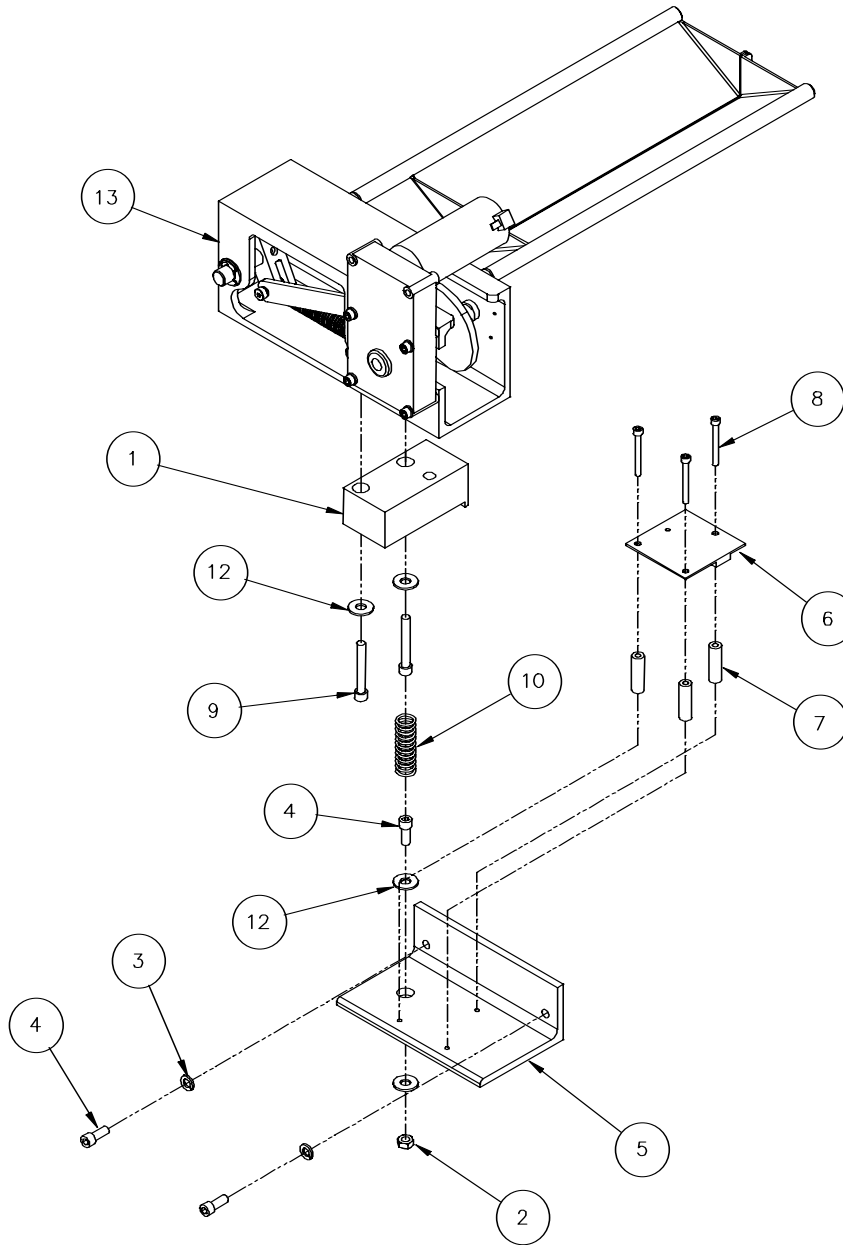

Not Shown, Item 11- NCWS Wiring Harness

| ITEM | QTY | PART NUMBER | DESCRIPTION |
|------|---|-------------|---|
| 1 | 1 | 290725 | Magnet Mount Assembly |
| 2 | 1 | 290086 | Hex Nut, Nylon Insert, 1/4-20 |
| 3 | 2 | 213142 | Lock Washer, Zinc Plated, 1/4" |
| 4 | 3 | 213145 | Cap Screw, Socket Head, Zinc Plated, 1/4-20 x 5/8 |
| 5 | 1 | 290650 | Bracket, NCWS, Board Mount |
| 6 | 1 | 290519 | Circuit Board, NCWS |
| 7 | 3 | 290657 | Spacer, Round, Unthreaded, Nylon, 3/8 x #8 x 1.25" |
| 8 | 3 | 290658 | Cap Screw, Socket Head, Zinc Plated, 8-32 x 1 1/2 |
| 9 | 2 | 290659 | Cap Screw, Socket Head, Zinc Plated, 1/4-20 x 1 3/4 |
| 10 | 1 | 290656 | Spring, NCWS |
| 11 | 1 | 290655 | Harness, NCWS |
| 12 | 4 | 213141 | Flat Washer, Zinc Plated, 1/4" |
| 13 | Accumulator Assembly, see page 39 for details | | |