



**280-F**

**Frozen Fry Dispenser**

Equipment Manual  
English (Rev H)  
P/N 293511



**Manufactured By  
Automated Equipment LLC**

5140 Moundview Drive  
Red Wing, MN 55066 U.S.A.

**For Warranty Service & Technical Support:**

**US & Canada call: 1 (800) 248-2724**

**International call: 1 (651) 385-2273**

**Sales Fax: 1 (651) 385-2166**

**Service Fax: 1 (651) 385-2172**

<http://www.autoequiplc.com>

**Business Hours:**

**Monday – Friday: 8:00 AM to 5:00 PM CST**

**(excluding. holidays)**

After hours, your call will be handled by a voice mail paging service. The on-call technician will be paged and will return your call.

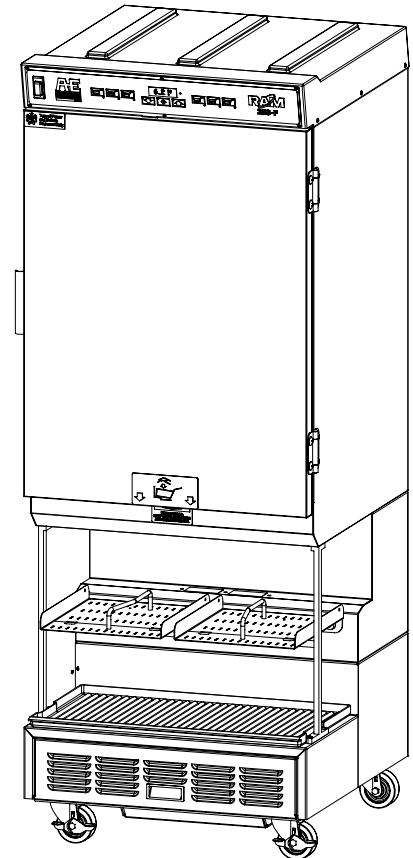

**Table of Contents**

**Introduction ..... 1**

**Unpacking & Installation ..... 1**

**Intended Use ..... 1**

**Specifications..... 1**

**Warranty ..... 2**

**Service Information ..... 3**

**Equipment Safety..... 4**

**Dispenser Assembly (Models prior to s/n 28FR0802B0249)..... 6**

**Dispenser Assembly (Models after and including s/n 28FR0802B0249) ..... 9**

**Disassembly, Defrost & Cleaning..... 12**

**Dispenser Startup ..... 13**

**Operation ..... 14**

**Daily Opening and Closing ..... 15**

**User Function Menu Structure ..... 18**

**Manager Function Menu Structure..... 19**

**Diagnostic Function Menu Structure ..... 20**

**Error Detection..... 23**

**Troubleshooting..... 24**

**Calibrations and Adjustments ..... 27**

**Part Identification..... 30**

**Refrigeration System..... 40**

**Electrical Diagram – Two Temperature Probe Configuration..... 44**

**Electrical Diagram – Single Temperature Probe Configuration ..... 45**

The information in this manual is subject to change without notice.

IN NO EVENT WILL AUTOMATED EQUIPMENT LLC BE LIABLE FOR TECHNICAL OR EDITORIAL OMISSIONS MADE HEREIN, NOR FOR DIRECT, SPECIAL, INCIDENTAL, OR CONSEQUENTIAL DAMAGES RESULTING FROM THE FURNISHING, PERFORMANCE, OR USE OF THIS MATERIAL.

This manual is copyrighted with all rights reserved. Under the copyright laws, this manual may not be copied, in whole or part, without the written consent of Automated Equipment LLC.

Product names mentioned herein are for identification purposes only, and may be trademarks and/or registered trademarks of their respective companies.

## Introduction

This manual contains important information on the proper installation, operation, and care of the RAM 280-F Frozen Fry Dispenser. Following the instructions and procedures in this document will ensure that your dispenser provides years of reliable service. If any problems with the dispenser arise, this manual will also provide troubleshooting tips and service information.

## Unpacking & Installation

Remove all packing material from Dispenser. Open Cabinet Door. Disassemble, clean, sanitize and dry the Hopper and Accumulator assemblies. Clean, sanitize and dry Fry Baskets. (see [pages 6-12](#) for assembly, disassembly & cleaning). Reassemble all components (see [pages 13-17](#) for startup and operation).

## Intended Use

The Frozen Fry Dispenser is intended to maintain and dispense frozen fries from two independent hoppers. Each is capable of dispensing different volumes of fries.

All product should be removed daily for cleaning and maintenance of the dispenser. The performance of the system requires that recommended procedures for storage and use of the dispensed product be followed closely.

### HAZARD COMMUNICATION STANDARD:

Hazard Communication Standard (HCS) Procedures in this manual may include the use of chemical products. These chemical products will be highlighted with boldface letters followed by the abbreviation (HCS) in the text of the procedure. See the HCS Manual for the appropriate Material Safety Data Sheets (MSDS).

**SERIAL NUMBER:** The information on the serial number identification label is as follows:

|                        |                |                |
|------------------------|----------------|----------------|
| Examples:              | 28FR0711A00183 | LONR0803C00294 |
| Model                  | 28F            | LON            |
| Manufacturing Facility | R              | R              |
| Year                   | 07             | 08             |
| Month                  | 11             | 03             |
| Revision Level         | A              | C              |
| Sequence Number        | 00183          | 00294          |

## Specifications

### Electrical Requirements:

Domestic:

- 120 Volts a.c., 60 Hertz, 8 Amps, 1Φ

International:

- 220 - 240 Volts a.c., 50 Hertz, 3.3 Amps, 1Φ (Revisions A, B, C)
- 220 - 240 Volts a.c., 50 Hertz, 3.7 Amps, 1Φ (Revision D)

**Internal Circuit Breaker:** 15 Amps

### Dimensions:

- 28" wide, 29" deep, 75" high  
(712 mm x 737mm x 1905mm)

### Recommended Operating Dimensions:

- 30" wide, 31" deep, 79" high  
(762 mm x 788mm x1930mm)

**Weight:** 440 lbs (200 kg)

### Hopper Capacity:

- 60 lbs(27.3 kg) fries, 30Lbs(13.6 kg) per Hopper, weight may vary with product.

### Operating Temperature:

- -2°F to 10°F (-19°C to -12°C)  
(Recommended Ambient Operating Temperature of 75°F (24°C))
- ST (Sub Tropical)

### Refrigeration:

Domestic:

- R-404A: 14.75 oz,

International:

- R-404A: 420 g -1250-2640 kPa

### Maximum Operating Altitude & Safe Tilt:

- Maximum Altitude: 7000 ft (2,134 meters), Maximum Tilt = 10 degrees

**Noise Emissions:** < 70 dB (A)

## FCC STATEMENT

**WARNING: This equipment generates, uses, and can radiate radio frequency energy and, if not installed and used in accordance with the instruction manual, may cause interference to radio communications.**

## Warranty

The terms "we", "us", "our" or "factory" hereinafter refer to Automated Equipment LLC. We warrant the purchased product to be free from manufacturing defects in material and workmanship under normal use and conditions for the period and component specified below. Warranty is part only unless otherwise specified.

| <u>Components Covered</u>                               | <u>Term is located on dispenser</u> |
|---|-------------------------------------|
| Electronic Circuit Board Assemblies                     | See Serial # / Warranty Label       |
| Electrical and Mechanical Moving Parts                  | See Serial # / Warranty Label       |
| Structural frame work or enclosures                     | See Serial # / Warranty Label       |
| Refrigeration Compressor                                | See Serial # / Warranty Label       |
| Crew removable components:                              | (no labor, part only)               |
| <input type="checkbox"/> Baskets                        | 90 days                             |
| <input type="checkbox"/> Basket Rack and Guides         | 90 days                             |
| <input type="checkbox"/> Drip Tray                      | 90 days                             |
| <input type="checkbox"/> Power Cord                     | 90 days                             |
| <input type="checkbox"/> Hoppers, Fry Diverters & Drums | 90 days                             |
| <input type="checkbox"/> Flap Doors                     | 90 days                             |
| <input type="checkbox"/> Accumulator Doors & Housings   | 90 days                             |

**The Warranty period commences on the date of shipment of the RAM 280-F Frozen Fry Dispenser (hereinafter "Product") from our manufacturing facility.**

EXCEPT AS OTHERWISE PROVIDED HEREIN WE MAKE NO OTHER WARRANTIES, EXPRESSED OR IMPLIED AND SPECIFICALLY DISCLAIM ANY WARRANTY OF MERCHANTABILITY OR FITNESS FOR A PARTICULAR PURPOSE.

We shall not be liable for any direct, indirect, consequential damages (including damages for loss of business profits, business interruption, loss of business information and the like) arising out of the use of or inability to use the Product.

THIS WARRANTY IS VOID IF THE PRODUCT IS NOT FUNCTIONING CORRECTLY DUE TO ABUSE OR NEGLIGENCE BY THE PURCHASER, ITS EMPLOYEES, AGENTS, OR OTHER REPRESENTATIVES EITHER BY BREAKING, BENDING, MISUSE, ABUSE, DROPPING, ALTERATION, IMPROPER MAINTENANCE OR ANY OTHER FORM OF NEGLIGENCE OR IMPROPER USAGE. THIS WARRANTY DOES NOT COVER DAMAGE TO THE PRODUCT CAUSED BY NATURAL CAUSES SUCH AS LIGHTNING, ELECTRICAL CURRENT FLUCTUATIONS, FLOOD, FIRE, TORNADOES, OR OTHER ACTS OF GOD. WE WILL INVOICE PURCHASER FOR REPAIRS MADE NECESSARY BY THE HEREIN LISTED CAUSES.

This warranty is governed by the substantive laws of Minnesota, U.S.A., without giving effect to the conflict of law provisions.

This warranty is non-transferable and applies only to the original Purchaser.

## Service Information

### Warranty Service

Warranty service must be initiated by calling our Technical Support Hotline at 1-800-248-2724 (U.S./Canada) or 651-385-2273 to establish all warranty requests.

Our Technical Support personnel will determine the cause of failure and provide appropriate resolution. Any required replacement parts will be provided by us or by an authorized Service Support Center/Parts Distributor.

Our Technical Support personnel will make all reasonable efforts to perform such repairs during normal business hours, and will not be responsible for any after-hours or holiday charges.

### Non-Warranty Service

Service is normally conducted by customer appointed personnel, or by contracting a local service agent. The service person must be licensed in refrigeration to troubleshoot, open, or repair refrigeration and related systems.

Service fees are in accordance with industry standards.

Replacement parts are available through local Service Support Center/Parts Distributors or direct from us by calling 1-800-248-2724 (U.S./Canada) or 651-385-2273 in the event a local distributor is not available.

Our Technical Support Hot Line is available for telephone assistance providing product technical support, parts and parts information, and service agent referral.

**Contact our Technical Support Hotline at 1-800-248-2724 (U.S./Canada) or 651-385-2273.**

Record the following information for your records:

---

Date of Installation

---

Service Agency Telephone

---

Serial Number

When repairing this unit, use only replacement parts supplied by us, or supplied by our Factory Authorized Parts Distributor. Use of replacement parts other than those supplied by us or by our Factory Authorized Parts Distributor will void the warranty.

All shipping charges are F.O.B. factory, and are subject to change without notice. Prices will be those in effect at the time of shipment.

Automated Equipment LLC. reserves the right to make suitable substitutions in materials, depending upon their availability.

## Equipment Safety

- Turn the Power Switch off and disconnect the Dispenser Power Cord from the wall outlet before cleaning, moving or servicing the Dispenser.
- Inspect the Dispenser on a regular basis to identify potential problems before they occur.
- Keep the Dispenser clean.
- Keep hands away from the Accumulator Doors and Dispenser Drums while the Dispenser is operating.
- Fry Baskets may be hot. Pick them up by the handles only.
- Do NOT roll the Dispenser to the back sink for cleaning, this will cause unnecessary wear on the Dispenser.
- If the Power Cord is damaged it must be replaced by the manufacturer or its service agent or a similarly qualified person in order to avoid a hazard.
- Use only the Power Cord that came with the Dispenser. Do NOT use an extension cord.
- Do NOT modify the Power Cord
- In a safety emergency, immediately disconnect the Dispenser Power Cord from the wall outlet.
- Do NOT obstruct access to the wall outlet or place pressure on the Power Cord.
- Only trained and/or qualified personnel should service the electrical system.
- **DO NOT SPRAY THE DISPENSER WITH LIQUID OR SOLVENTS.**  
It is not sealed against jetting fluids and contamination may get into sensitive components. Spraying the dispenser may void the warranty.
- Use caution when handling heavy parts such as back and top panels.
- Always reinstall service panels when maintenance is complete.
- Do NOT drill or otherwise puncture cabinet walls or top.
- Keep unit upright at all times.

### **CAUTION!**

**Only trained and/or qualified personnel should perform service on this equipment.**

**Only trained and/or qualified personnel, licensed in refrigeration, should perform service on the refrigeration systems of this equipment.**

**Service functions described in this manual could cause irreversible damage to the equipment and/or injury to personnel if performed improperly.**

**If the power cord is damaged, it must be replaced by the manufacturer, or its service agent, or a similarly qualified person in order to avoid a hazard.**

Equipment Safety Cont.

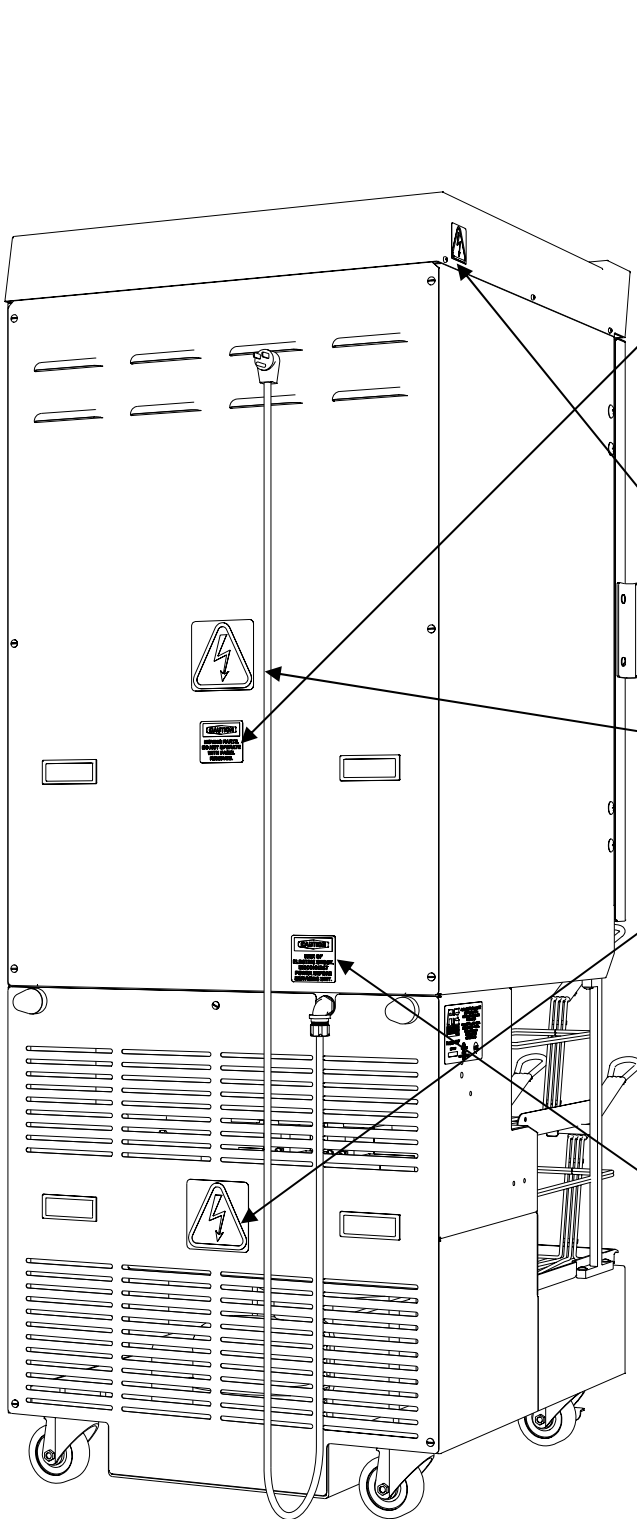

**CAUTION**  
**MOVING PARTS.**  
**DO NOT OPERATE**  
**WITH PANEL**  
**REMOVED.**

Label is located on the rear access panel and applies to each of the drum motor and accumulator assemblies within the enclosure.

CAUTION, MOVING PARTS.  
DO NOT OPERATE WITH PANEL REMOVED

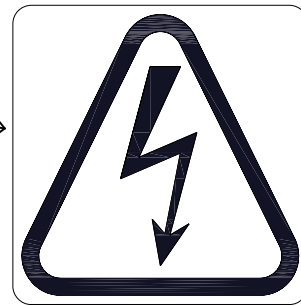

Label is located on Top Cover and Rear Access Panels.

INDICATES HAZARDOUS VOLTAGE WITHIN

**CAUTION**  
**RISK OF**  
**ELECTRIC SHOCK.**  
**DISCONNECT**  
**POWER BEFORE**  
**SERVICING UNIT.**

Label is located near Power Cord inlet.

CAUTION, RISK OF ELECTRIC SHOCK.  
DISCONNECT POWER BEFORE  
SERVICING UNIT.

## Dispenser Assembly (Models prior to s/n 28FR0802B0249)

**Note:** Before assembling the Dispenser it is recommended that all parts be cleaned, sanitized, dry, and handled in a sanitary manner. Refer to the Cleaning Procedures ([Page 12](#)) for more information.

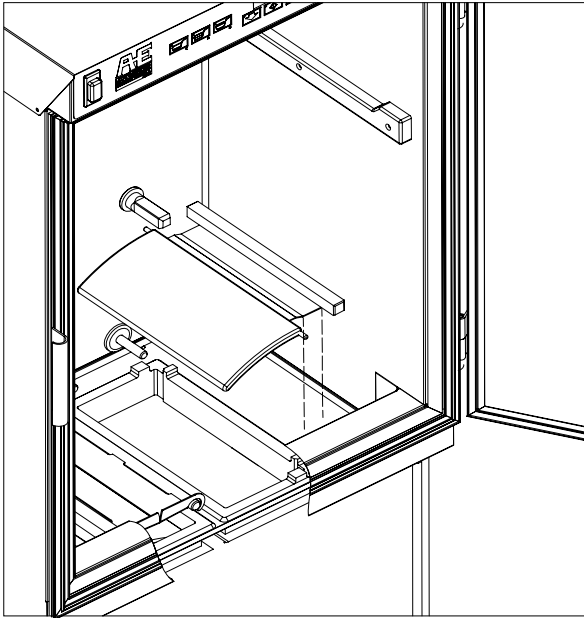

**Flap Door Assembly**

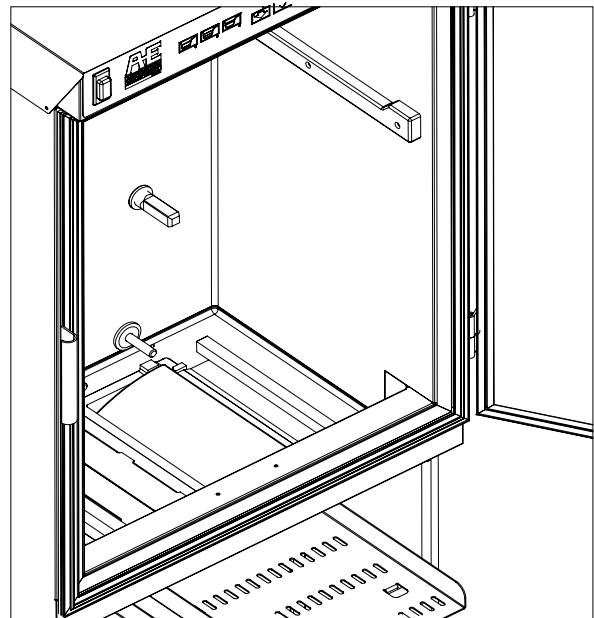

**Flap Door Installed**

Open the cabinet door. Install the left and right flap door assemblies as shown above.

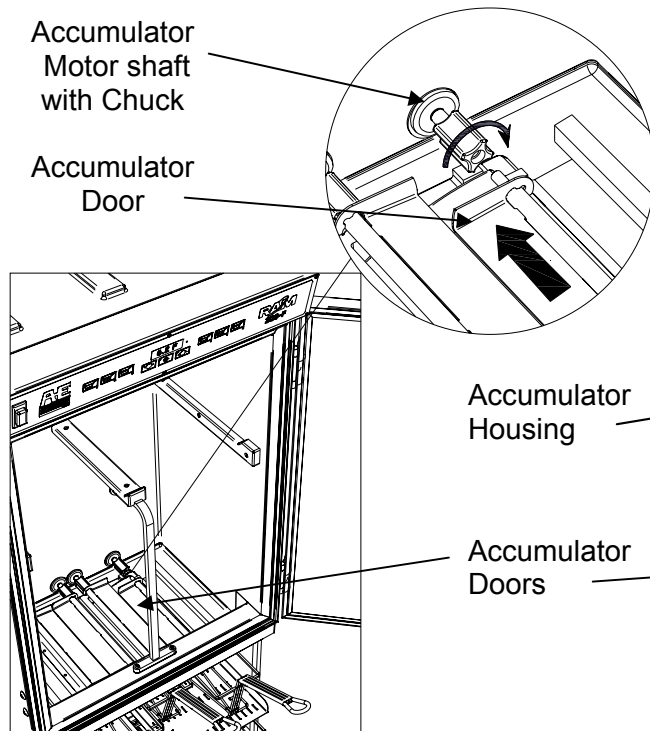

**Accumulator Door Assembly**

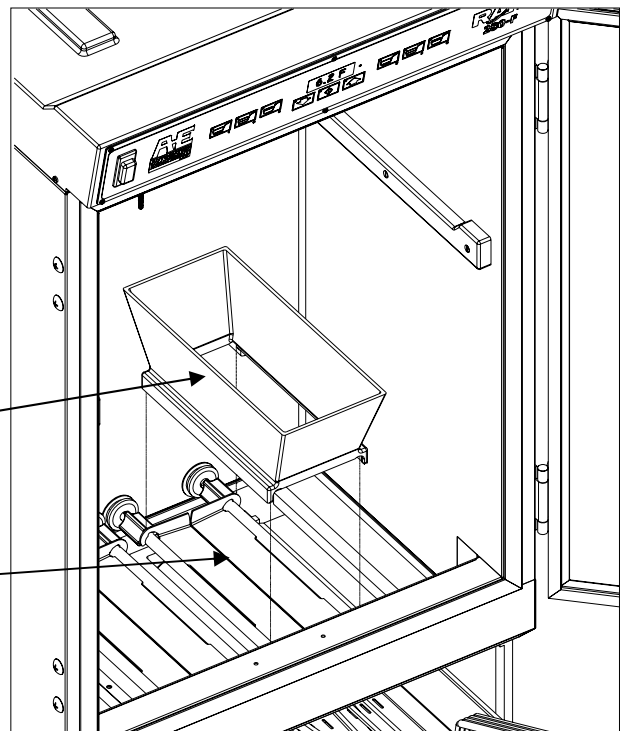

**Accumulator Housing Assembly**

Install the left and right Accumulator Doors by first inserting the rear of the doors onto the Accumulator Motor Shafts, then slide the Chucks forward and rotate the chucks clockwise until finger-tight. Install the left and right Accumulator Housings over the Accumulator Doors.



**Dispenser Assembly Cont.**

**Note: Accumulator Housings, Drums, and Fry Diverters are universal to left, and right, positions within the cabinet. The Hoppers are NOT universal to the left, and right, positions within the cabinet.**

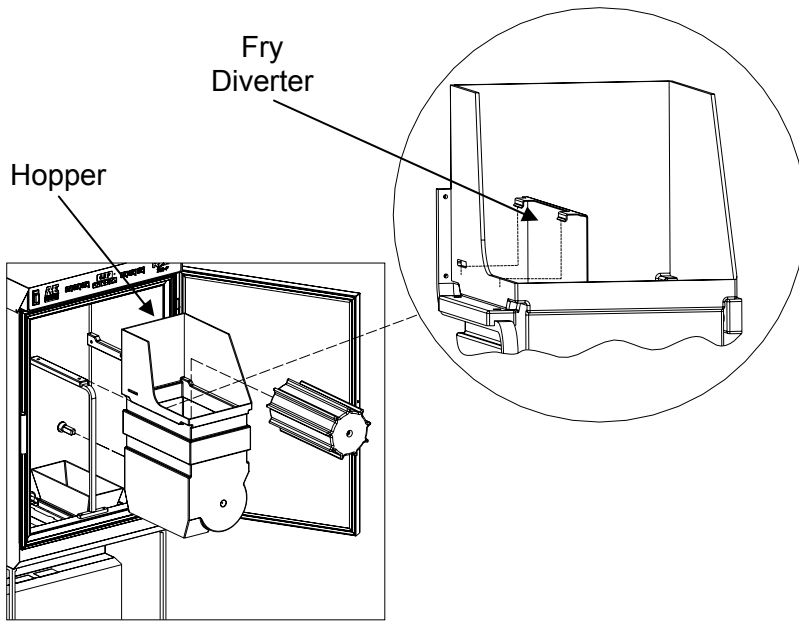

**Fry Diverter Assembly**

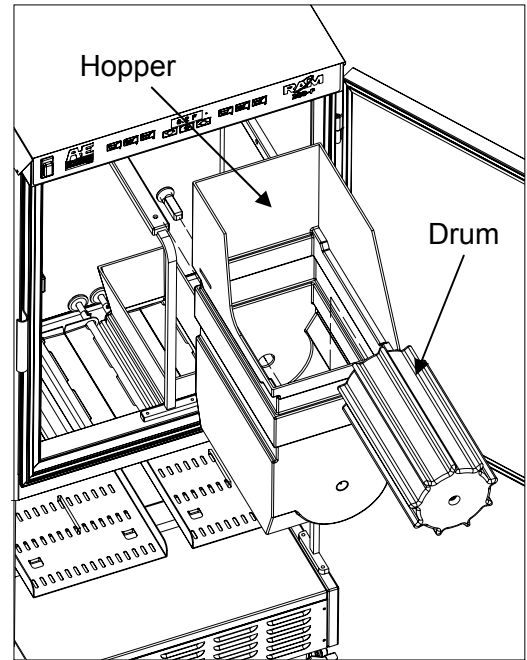

**Drum and Hopper Assembly**

Install the Fry Diverters in the Hoppers by sliding the Fry Diverters into the slot located on the inside Hopper walls. Install Drums into the Hoppers making sure the square opening in the drum is pointed to the rear of the Hopper. Repeat assembly for left and right hopper. Install the hopper assemblies into the cabinet by sliding them onto the hopper supports. **DO NOT** force the drum on to the shaft. Rotate the drum in the hopper until the square opening meshes with the drum motor shaft, then slide the hopper assembly back until it drops into place.

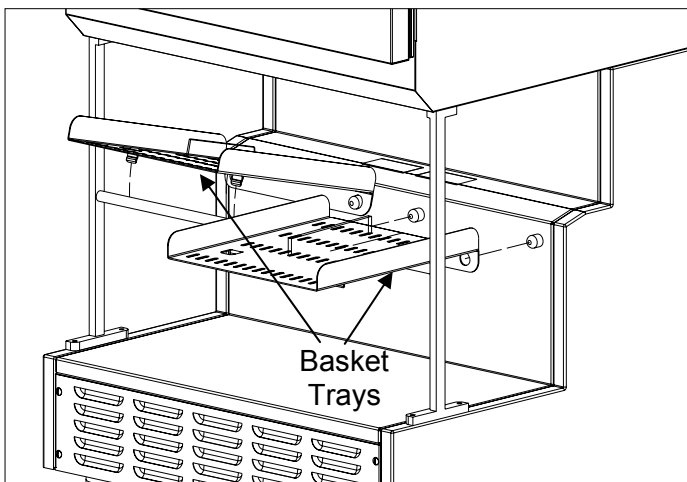

**Basket Tray Assembly**

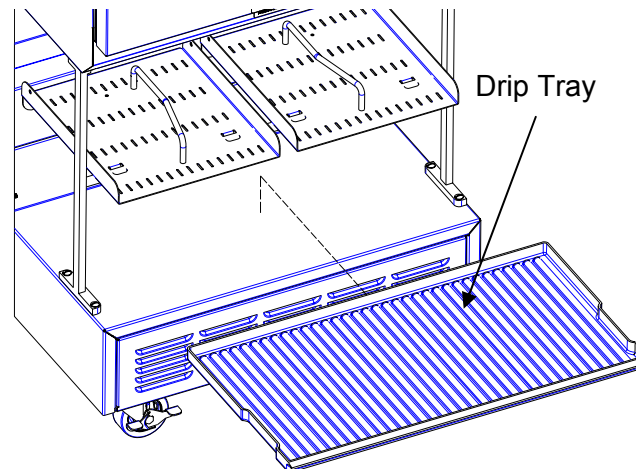

**Drip Tray assembly**

Once the Accumulator Housings and Hopper Assemblies are in place, close the Cabinet Door. Assemble Basket Tray and Drip Tray to lower dispensing area. Basket Trays are not universal to the left and right positions.

### **Using the Hash-brown Rack**

The RAM 280-F cabinet can be used to store frozen hash-browns while serving breakfast. To use the cabinet for hash-brown storage, properly assemble the dispenser ([pages 6-11](#)), then install the hash-brown rack accessory as shown in the diagram below. The rack will serve as a shelf inside the refrigerated cabinet for hash-brown storage.

Note: The hash-brown racks should be removed during normal operation.

**Caution:** Do not store hash-browns on the drum below the rack, this can damage the dispenser.

Insert the four rods of the hash-brown rack into the holes in the side of the hopper then lower the rack onto the fry diverter.

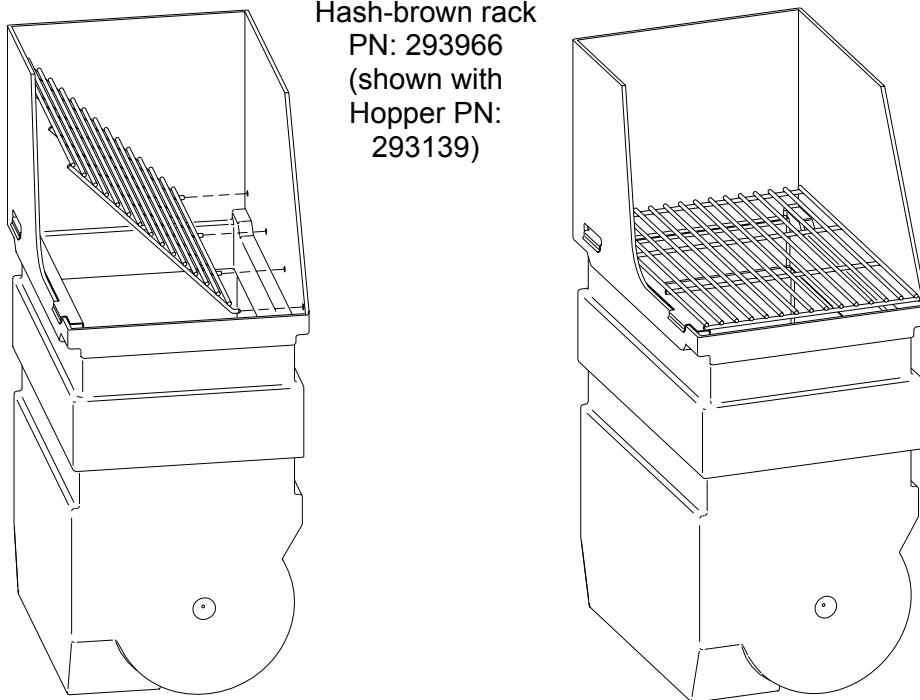

Hash-brown rack  
PN: 293966  
(shown with  
Hopper PN:  
293139)

**Hash-brown rack installation**

## Dispenser Assembly (Models after and including s/n 28FR0802B0249)

**Note:** Before assembling the Dispenser it is recommended that all parts be cleaned, sanitized, dry, and handled in a sanitary manner. Refer to the Cleaning Procedures ([page 12](#)) for more information.

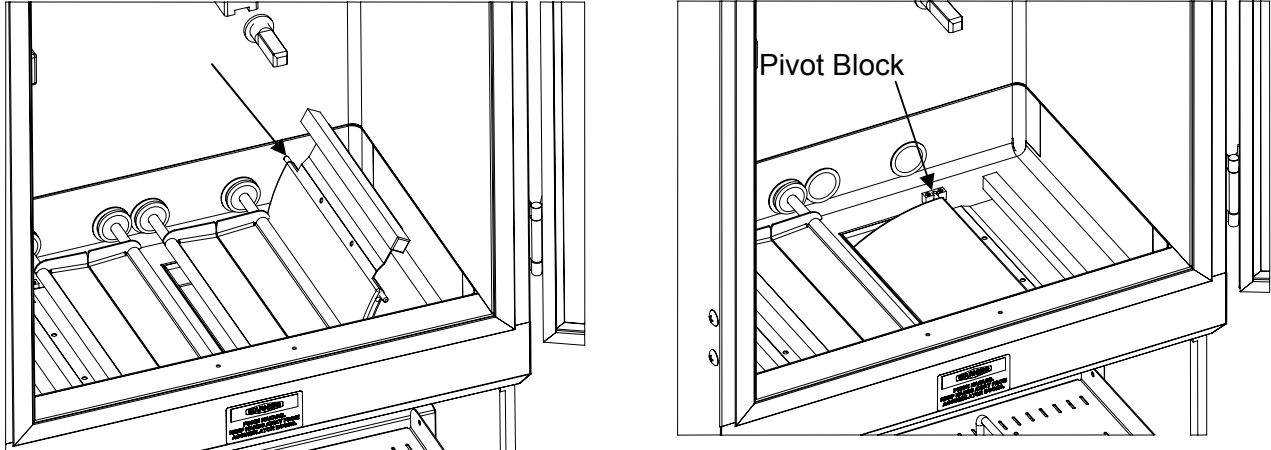

Open the cabinet door. Accumulator doors are pre-installed. Install the left and right flap doors by slipping them under the accumulator doors and seating the pivot pin into the plastic pivot blocks, as shown above. (Accumulator Doors are hidden for clarity in Right Hand view).

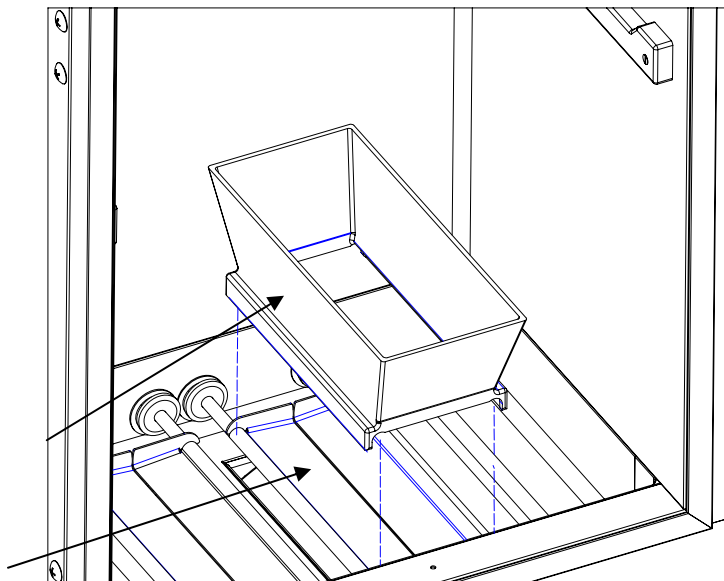

### Accumulator Housing Assembly

Install the left and right Accumulator Housings over the Accumulator Doors.

**Dispenser Assembly Cont.**

**Note: Accumulator Housings, Drums, and Fry Diverters are universal to left, and right, positions within the cabinet. The Hoppers and Basket trays are NOT universal to the left, and right, positions of the cabinet.**

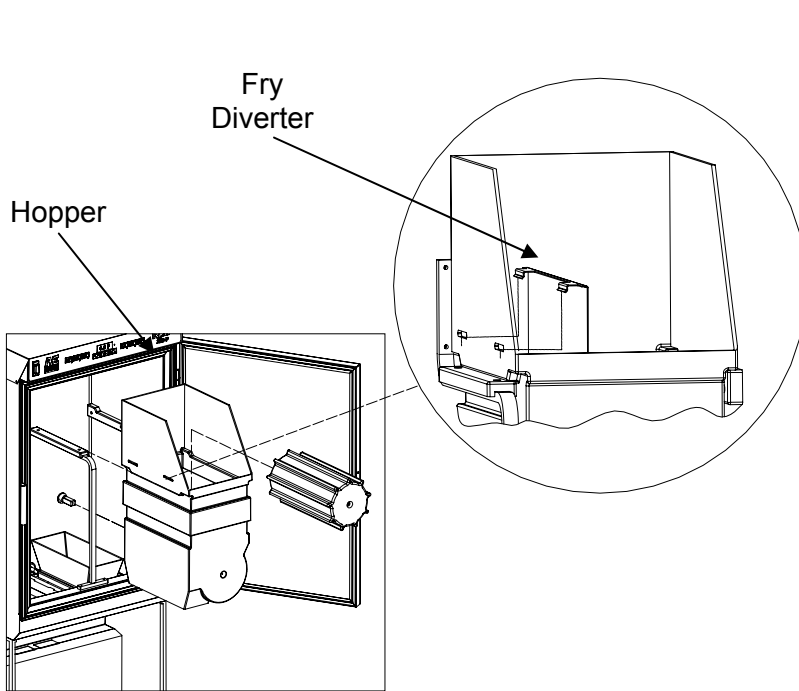

**Fry Diverter Assembly**

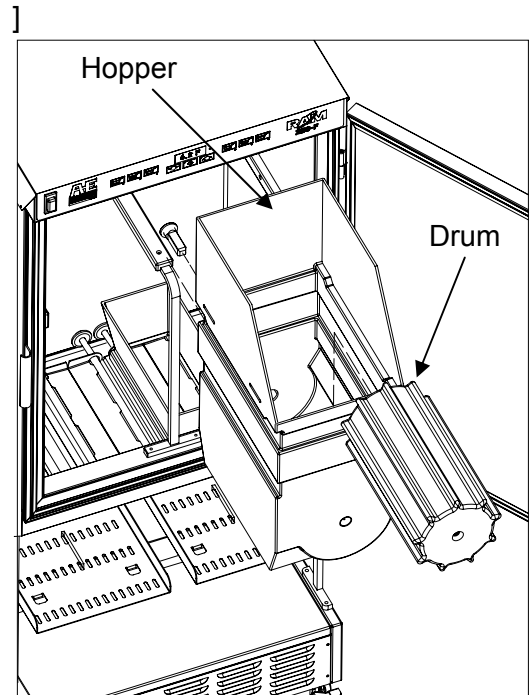

**Drum and Hopper Assembly**

Install the Fry Diverters in the Hoppers by sliding the Fry Diverter tabs into the slots located on the inside Hopper walls. Install Drums into the Hoppers making sure the square opening in the drum is pointed toward the rear of the Hopper. Repeat assembly for left and right hoppers. Install the hopper assemblies into the cabinet by sliding them onto the hopper supports. **DO NOT** force the drum on to the shaft. Rotate the drum in the hopper until the square opening meshes with the drum motor shaft, then slide the hopper assembly backward until it drops into place.

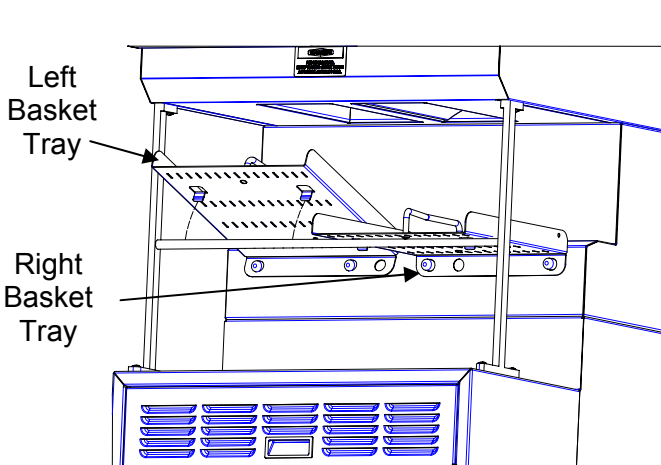

**Basket Tray Assembly**

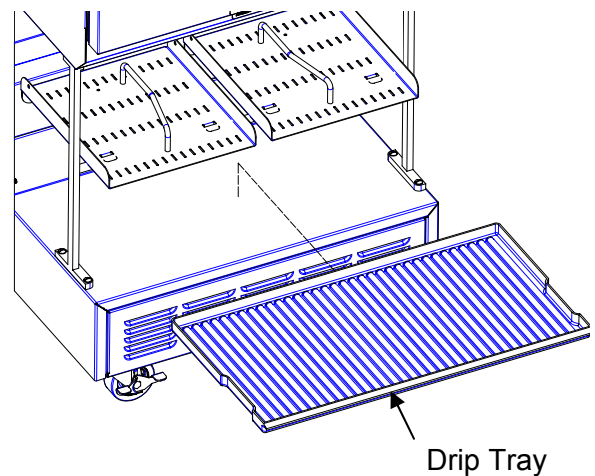

**Drip Tray assembly**

Once the Accumulator Housings and Hopper Assemblies are in place, close the Cabinet Door. Assemble Basket Tray and Drip Tray to lower dispensing area. Basket Trays are not universal to the left and right positions.

### **Using the Hash-brown Rack**

The RAM 280-F cabinet can be used to store frozen hash-browns while serving breakfast. To use the cabinet for hash-brown storage, properly assemble the dispenser ([pages 9-11](#)), then install the hash-brown rack accessory as shown in the diagram below. The rack will serve as a shelf inside the refrigerated cabinet for hash-brown storage.

Note: The hash-brown racks should be removed during fry dispensing.

**Caution:** Do not store hash-browns on the drum below the rack, this can damage the dispenser.

Insert the four rods of the hash-brown rack into the holes in the side of the hopper then lower the rack onto the fry diverter.

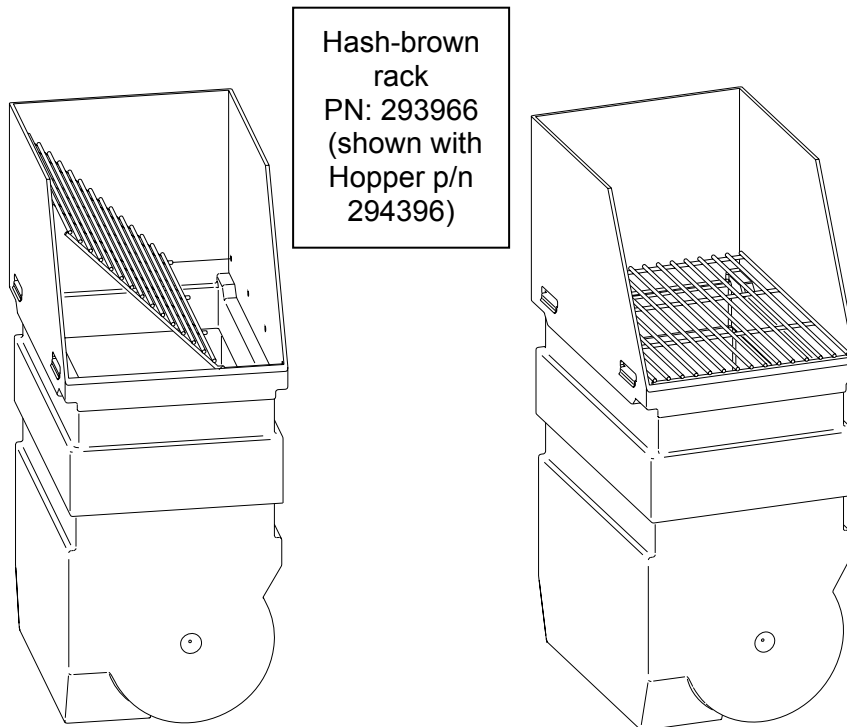

**Hash-brown rack installation**

## Disassembly, Defrost & Cleaning

**IMPORTANT!** These cleaning instructions are intended as a guide. Refer to your local, state, and federal regulations for any additional instructions and for cleaning frequency requirements.

Remove all Baskets from the dispense area. Open the Cabinet Door and remove the left and right Hopper Assemblies by lifting the front of the Hopper up slightly and pulling forward on assembly.

Remove any unused product from the Hoppers and Accumulator Housings by emptying the product into an approved storage container. Place the storage container immediately into a freezer to maintain frozen product.

### **Defrost**

Because the dispenser employs a cold wall design, it will be necessary to manually defrost the cabinet daily. After removing the product, using the On/Off Switch turn the power OFF and unplug the dispenser power cord. Open the Cabinet Door and allow 1 hour to defrost.

Note: Failure to turn the dispenser power off prior to defrosting the cabinet may result in a cabinet over-temperature error. (Error -5-).

**Caution: Never use a sharp object to remove frost build-up. Never drill or otherwise puncture cabinet walls or top.**

Lift and remove the Accumulator Housings.

For dispensers with removable accumulator doors: remove the Accumulator Doors by rotating the chucks Counter-Clockwise until unlocked, then pull the accumulator doors forward.

Lift and remove left and right Flap door assemblies.

Remove left and right Basket Guide assemblies from the Dispenser by lifting up on the front of the guide until it unlatches, then pull outward and upward. Remove Drip Tray by lifting, tilting and sliding forward.

Take the removable components from the Dispenser to the washing area. Wash them with a hot solution of detergent and water. Rinse each component with clear water and sanitize (wash/rinse/sanitize) (**HCS**). Allow components to air dry,.

**NOTE:** The removable components are NOT dishwasher safe.

Move the Dispenser out from the wall to clean behind and underneath it.

Do NOT roll the dispenser to the back sink for cleaning, this will cause unnecessary wear on the dispenser.

Once the cabinet is free of frost, wipe down the internal and external cabinet with a hot solution of detergent and water. Rinse with clear water and repeat wipe down with sanitizing solution (**HCS**) and allow to air dry.

**Warning: Do not spray the Dispenser with Liquid or Solvents. The Dispenser does not provide a water tight seal. Contaminants and moisture may get into sensitive components.**

Dry all components and reassemble the Dispenser ([page 6-11](#)). Move Dispenser back into place.

**Notice: The dispenser must be accessible from all sides for routine cleaning and maintenance. A minimum of 0.5" (13 mm) clearance on both sides and 2" (50 mm) behind the dispenser is recommended.**

## Dispenser Startup

Make sure Power Switch, located on the left portion of the operator panel, is turned off. Assemble the Dispenser ([Pages 6-11](#)). Plug the Power Cord into an approved outlet and turn the Dispenser on.

**Note: Turn Dispenser on a minimum of 90 minutes (depending on ambient temperature conditions) before loading frozen product into the Dispenser. Once the temperature display has dropped to 10°F (-12°C) load frozen product into Dispenser and use the Dispenser.**

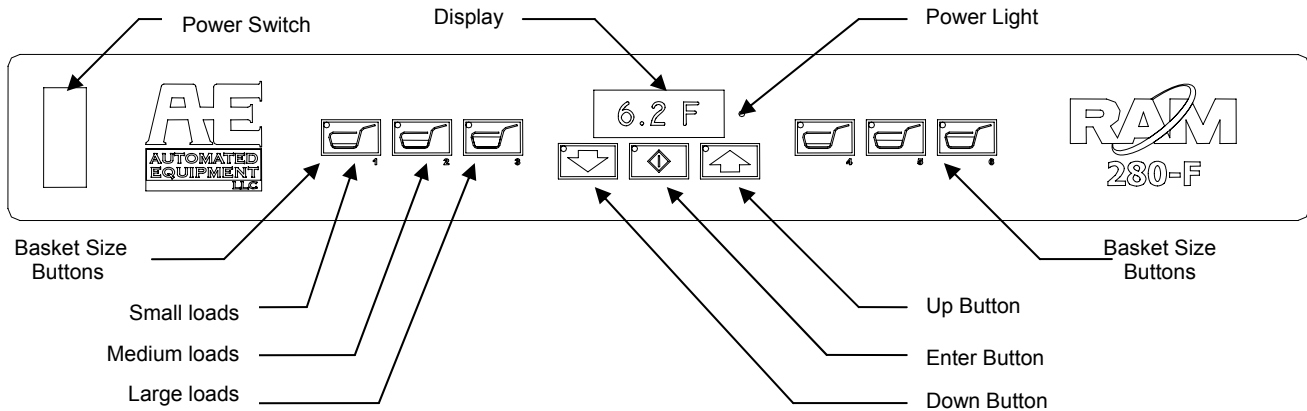





The Operator Panel consists of a Power Switch and three groups of controls: the Left Hopper controls, center System controls with Data Display, and the Right Hopper controls. Each Hopper is controlled as if it were an independent dispenser.

On power up, the display will very briefly show the Software Name, Software Version, Copyright Notice, and then the Main Screen (typically the dispenser temperature). The Dispenser will NOT respond to keypad selections before the Main Screen is displayed.

The Main Screen will appear as shown above. The number displayed in the center represents the interior cabinet temperature.

The operator panel is used to make basket load size selections and to access controller functions.

**Note: The Managers Menu and Diagnostic Menu may require a manager's password to access the Functions. By Default these Passwords are disabled.**

- Use the Up  and Down  Arrow Buttons to access a desired function. (See [pages 18-22](#) for a complete list of functions and their descriptions.)
  - Press the Enter  Button to select the desired function.
  - Basket Size Buttons also function as numbers: 
- (e.g. Left Small=1, Left Medium=2, Left Large=3, Right Small=4, Right Medium=5, Right Large=6)



## Operation

**Note: This machine is to be used only for dispensing frozen fries or other approved product. Any other use may cause injury to personnel or damage to the machine.**

The Frozen Fry Dispenser is intended to maintain and dispense frozen fries on demand from two independent hoppers eliminating the need for staging full baskets of fries. Dispensing and cooking fries direct from the freezer results in improved fry quality, consistency and yield.

**Do not stage full baskets of fries on the bottom tray. The lower tray area should be used for empty fry basket storage only.**

### Loading the Hoppers

**Note: To achieve optimum fry yield and the most consistent basket loads, it is important to use the following technique for loading frozen fries into the Hopper.**

The dispenser will accept 60 lbs (27.3kg) of French fries, 30 lbs (13.6kg) per hopper (approximately 5 bags per hopper) Hopper capacity may vary depending on the product.

**Warning: Pinch Hazard. Personnel should take care not to place hands or fingers near the Drum inside the Hoppers while this machine is in operation. Hands or fingers could be pinched between the Drum and the Hopper as the Drum turns.**

**Note: Do NOT shake or drop fries from the bag or box into the Hopper, this will result in unnecessary fry breakage.**

For each bag or box of fries:

1. Remove the bag of fries from the case. Be careful not to crush the fries.
2. Open the top of the bag or box completely. (A partially open bag may retain fries.)
3. Hold the opened end of the bag closed with your hand and lay it in the Hopper with the opening toward the side opposite of the Diverter.
4. Release the opened end of the bag or box.
5. Empty the bag into the Hopper by pulling it evenly toward the diverter. When adding multiple bags of fries, alternate the placement of the bag in the Hopper opposite of the previous bag. The second bag of fries should be emptied into the Hopper with the opening toward the Diverter, and pulling it evenly toward the Hopper wall opposite the Diverter.
6. This crisscross loading method assures an even distribution of fry lengths in the Hopper and the Baskets.
7. Repeat until each hopper is full.



## Daily Opening and Closing

### Setup and Operation

1. Fill one or both hoppers with product.

**Note: DO NOT SHAKE OR DROP the fries into the Hopper(s) (refer to “Loading the Hoppers”, [page 14](#)).**

2. Select a Basket Size Button for left and/or right Hopper to dispense desired load.

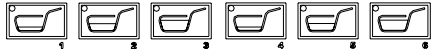



3. Default settings are:

- Small load = 0.50 LBS(225 gr)
- Medium load = 1.0 LBS(450 gr)
- Large load = 1.5 LBS(700 gr)

A LED light will illuminate next to the basket load size that is currently selected.

4. The drum motor for one/both sides will turn until the selected target weights are achieved. If there is insufficient product in the hopper a low fry warning will flash for the effected side. (blinking 'o').
5. Place a basket under the Accumulator Outlet for the selected side(s). Lift the front of the basket slightly and slide the basket forward over the basket sensor. The Accumulator Doors will open and close, discharging product into the waiting basket.
6. Remove the basket.
7. The dispenser will repeat step 4, preparing the next basket. The dispenser will automatically dispense as soon as the next basket is present.
8. **Automatic Load Size “Downshift”**  
**Note: For dispensers with serial numbers after LONR1001D01242 or dispensers with upgraded software.** When in the large load size setting, the machine will automatically shift the weight selection down to the medium setting if a basket has not been dispensed within 4 minutes. The weight selection will remain in the medium setting until the operator elects to change it.

### Daily Closing

Select '**Last Basket/Cancel Selections**' from the operator panel to cancel all currently selected basket loads: Using the Operator Panel, press the Up Arrow  Button until “U1” is displayed then press the Enter  Button.

Both sides will stop automatically refilling the accumulator housing. Dispense any fries present in the accumulator housing into a basket. The dispenser will NOT refill the housing.

Empty the dispenser. Dispose of any unused product or place into an approved storage container. Place container immediately into freezer to maintain frozen product.

Take the removable components from the Dispenser to the washing area. Wash them with a hot solution of detergent and water. Rinse with clear water and sanitize (**HCS**). Allow to air dry. (See 'Disassembly & Cleaning' instructions, [page 12](#).)

### **Defrost Cabinet Daily:**

**Turn the power switch off then open the Cabinet Door to allow the Dispenser to defrost for one hour or until free of frost.**

**Caution: Never use a sharp object to remove frost build-up.**



Once the cabinet is free of frost, wipe down the internal and external cabinet with a hot solution of detergent and water. Rinse with clear water and repeat wipe down with sanitizing solution (**HCS**) and allow to air dry.

Reassemble the Dispenser ([pages 6-11](#)). Move Dispenser back into place.

Note: Failure to turn the dispenser power off prior to defrosting the cabinet may result in a cabinet over-temperature error (Err 5).

### Last Basket/Cancel Selections

Before cleaning the dispenser or if it becomes necessary to stop automatic dispensing, the operator is able to cancel all selected basket loads. Both Drums will stop turning and any currently selected basket load lights will turn off for both sides of the dispenser. Any fries present in the accumulator housing will dispense automatically if a basket is presented. The dispenser will NOT refill the housing.

To cancel currently selected basket loads, using the Operator Panel, press the Up Arrow  Button until "U1" is displayed then press the Enter  Button. Both sides will stop automatically refilling the accumulator housing.

To return to normal operation for one or both sides select a Basket Size  Button for the effected side(s)

### Error Conditions

The dispenser's controller can detect an error or abnormal condition. When an error condition is detected the display will flash and state the error that has occurred. (i.e. "Err 4")

**Resetting Errors:** When an error does occur, it is normally reset by pushing the Enter  Button.

In the event the error is only effecting one side of the dispenser, the unselected basket size lights will also flash for the effected side and this side will be disabled until the error is reset. The unaffected side will continue to function normally.

**Note: Errors 5, 6 & 7 relating to the refrigeration systems, while requiring corrective action, will not disable the fry dispensing portion of the equipment.**

If the error condition persists, turn the Power Switch off and unplug the Power Cord from the wall outlet. Check the Power Cord for any obvious defect. Open the Cabinet Door to make sure the dispenser is properly assembled ([page 6-11](#)) and the product is loaded properly.

See [pages 23-26](#) for a complete list of errors and for a troubleshooting guide to aid in resolving the error conditions.

### Empty Hopper Warnings

If one or both of the hoppers runs empty, or the Dispenser is otherwise unable to dispense, the Empty Hopper Light for the effected side will flash, ('□' flashing in the display) and the unselected Basket Size Button LED lights for the effected side will flash. The dispense cycle will stop.

The blinking '□' for the effected side indicates the dispenser was unable to achieve the target weight on the accumulator doors. It may also indicate a scale obstruction, calibration problem, or bridged fries in the hopper.

If the Empty Hopper lights are flashing, check and/or fill the Hopper and press the currently selected Basket Load Button to restart the cycle.

**Note: The Dispenser will also retry the weigh cycle every 90 seconds.**

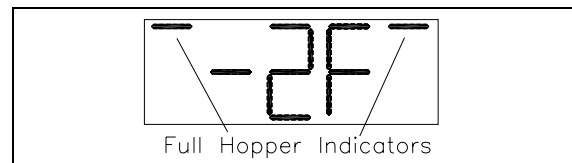

**Normal Operation**

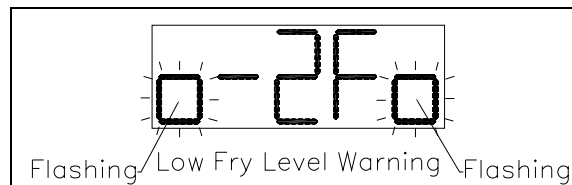

**Empty Hopper Warning**

### Door Ajar Warning



In Revision C and D dispensers equipped with a door switch, the controller is capable of detecting an open cabinet door. The temperature on the main display will flash alerting the operator that the door is ajar. The warning will automatically clear once the door is no longer open. If the door ajar condition persists for more than 15 minutes the refrigeration compressor will shut off until the door is closed again. Neither condition will effect the operation of the dispensing portion of the machine but is intended to alert the operator of an open door condition and avoiding unnecessary wear on the refrigeration systems of the RAM 280-F Frozen Fry Dispenser.

## **Bypass Mode of Operation**

Bypass mode will allow the one or both sides of the dispenser to remain operational in the event that a basket sensor fails. Bypass Mode is intended to be a temporary condition until a replacement basket sensor can be installed.



**Note: Bypass Mode is a volatile condition and will return to normal operation if the power is turned off and back on again.**

While in Bypass Mode the effected sides basket sensor is disabled and will not dispense fries automatically into a basket when presented.

To dispense the fries into a basket, press the selected Basket Size  Button after placing an empty basket under the accumulator door opening. The accumulator doors will cycle each time the Basket Size  Button is depressed.

While in Bypass Mode the dispenser will otherwise appear to operate normally, refilling the accumulator housings automatically after each dispense cycle with the selected load of fries.



**Note: Engaging Bypass Mode (D11) is performed from the Diagnostic Functions Menu ([pages 20-22](#)) using the Operator Panel on the front of the Dispenser and may require a manager's password to access the menu.**

To access the Diagnostics Menu, on the Operator Panel, press the Up Arrow  button until "U4" is displayed then press the Enter  button. The display will change to "-----" Enter the managers password (if set) using the basket size buttons. Then press the Enter  button.

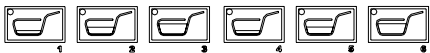
**Note: The Basket Size Buttons also function as number buttons:**









(e.g. the left medium basket button is number 2, and the right large basket button is number 6.)

The display will change to "d01". Press the Up Arrow  button until "d11" is displayed then press the Enter  button to access the Bypass Basket Sensor Function.

The display will read "[bYP]" with alternating flashing brackets. Use the Left or Right Basket Size  Buttons to select the side to be bypassed.

The display will default to the current sensor condition.

Use the Up Arrow  Button to select bypass mode for the effected side. The display will read "[YES" if the left side is selected, (" YES]" if the right side is selected.) Press the Enter  Button to execute bypass mode and exit to "d01". Press Enter  again to exit the diagnostics menu and enter bypass mode of operation.

To deselect bypass mode for the effected side: Press the Down Arrow  Button. The display will read "[ no" if the left side is selected (" no]" if the right side is selected). Press the Enter  Button to exit the function and return to "d01". Press the Enter  Button again to return to the main screen, or to return to normal operation turn the power off for 15 seconds then turn the power back on.

## User Function Menu Structure

| User Functions | Function Name   | Description   |
|----------------|---|---|
| Main Screen    | Main Screen   | Default condition of the display. Live temperature, error display, and hopper status (full/empty)   |
| U1             | Last Basket/ Cancel Selections  | Halts weighing in process.<br>Turns off all size button lights.<br>Immediate return to Main screen.   |
| U2             | Calibrate Scales<br><br><b>Note:</b> See procedure on <a href="#">page 27</a> | <ol style="list-style-type: none"> <li>1. Request side to calibrate. Display reads: “[CAL]” with alternating flashing brackets. Use Basket size button to select side.</li> <li>2. Waits for a basket to be placed for the side to be calibrated then empties the accumulator doors into the basket. The Display will read “[ -- “ (“ -- ]”) until a basket is presented.</li> <li>3. Remove hopper for side to be calibrated. NOTE: Leave the housing in place on the accumulator doors.</li> <li>4. Tares automatically. Display reads “[ 0.0 “ (“ 0.0 ]”)</li> <li>5. Waits for 1.0 lb reference. Display reads “[ 1.0 “ (“ 1.0 ]”) Place 1.0 lb (450 gr) weight on the accumulator doors.</li> <li>6. Waits for 2.0 lb reference. Display reads “[ 2.0 “ (“ 2.0 ]”) Place 2.0 lb (900 gr) weight on the accumulator doors.</li> <li>7. Waits for weight removal. Display will read “ --- “ Remove weight(s) from the accumulator doors.</li> <li>8. Reinstall hopper.</li> <li>9. The dispenser will return to normal operation with no basket size selected on effected side.</li> </ol> |
| U3             | Enter Manager Functions*  | Request password (if set) to enter manager functions.*<br>Display shows dashes only if a password is set.<br>Goes straight to “F1” if no password is set. ( <a href="#">page 19</a> )<br>Use basket size buttons to enter five-digit password†.<br>Press the Enter Button to execute and close function.<br>If the password was successfully entered, “F1” will be displayed. You are now in the Manager Menu. ( <a href="#">page 19</a> )  |
| U4             | Enter Diagnostic Functions*   | Request password, set or not, to enter diagnostic menu.<br>Display shows dashes only.<br>Use basket size buttons to enter five-digit password.<br><b>Note:</b> Password can be bypassed if not set. (press enter)<br>Enter button executes and closes function.<br>If the password was successfully entered, “d01” will be displayed. You are now in the Diagnostics Menu. ( <a href="#">page 20</a> )  |
| U5             | Software version  | Display shows current software version number. (i.e. “ 1.0 “<br>Enter button closes function.   |

- Use the Up  and Down  Arrow Buttons to find the desired function.

- Press the Enter  Button to select the desired function.

- Basket Size Buttons also function as numbers: 



(Left Small=1, Left Medium=2, Left Large=3, Right Small=4, Right Medium=5, Right Large=6)

\*Service Password to access both the Manager Menu and Diagnostic Menu: 22463†

†**Note: Using the Service Password to access the Manager Function menu will erase the manager’s password (if set) and restore it to default (no password).**

## Manager Function Menu Structure

| Manager Functions | Function Name                  | Description  |
|-------------------|--------------------------------|--|
| F1                | Exit Manager Functions         | Immediate return to the Main Screen.   |
| F2                | Set Basket Load Target weights | Allows the basket load targets to be customized for each basket load size. 0.25 lb to 2.0 lb (100gr-1000gr)<br>Display reads currently selected target load.<br>Size buttons select basket load size to change.<br>Up button increases target in 0.05 lb steps (25gr).<br>Down button decreases target in 0.05 lb steps (25gr).<br>Enter button stores new settings and closes function. |
| F3                | Set Target Temperature         | Allows the cabinet target temperature to be changed. The default is 0°F (-18°C). Display reads the current target temperature.<br>Up button will increase the target temperature in 1° increments.<br>Down button will decrease the target temperature in 1° increments.<br>Enter button stores the new setting, closes the function, and exits to F1.                                   |
| F4                | Set Differential               | Sets the temperature difference that activates the refrigeration compressor. For example: if the target temperature is 5°F with a 6° differential, the compressor will cycle on at 11°F and off at 5°F. Default is 5°F (3°C) for one probe and 6°F (3°C) for two probe controlled dispensers. Setting is adjustable from 4°F to 15°F (2°C to 8°C).<br>Display reads “dF. 5F”             |
| F5                | Set Metric or English          | Changes from English to Metric units. Display will default to currently selected unit.<br>Up button sets metric units. Display reads “gr”.<br>Down button sets English units. Display reads “Lb”<br>Enter button saves setting and closes function.<br><b>Note:</b> Must Recalibrate Scales. See procedure on <a href="#">page 27</a> .  |
| F6                | Set Password                   | Allows a password to be set to access both manager and diagnostic functions. (default is no password)<br>Display shows dashes<br>Use Size buttons to enter a 5 digit password then press the enter button to save the password and exit.<br><b>Note:</b> Password must be entered twice. (double entry)<br>Entering “11111” twice will clear any passwords.                              |

- Use the Up  and Down  Arrow Buttons to find the desired function.
- Press the Enter  Button to select the desired function.

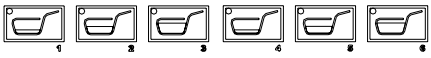
- Basket Size Buttons also function as numbers:   
(Left Small=1, Left Medium=2, Left Large=3, Right Small=4, Right Medium=5, Right Large=6)

Service Password to access both the Manager Menu and Diagnostic Menu: 22463

**Note: Using the Service Password to access the Manager Function menu will erase the manager’s password (if set) and restore it to default (no password).**





## Diagnostic Function Menu Structure

| Diagnostic Functions | Function Name   | Description  |
|----------------------|---|--|
| <b>D01</b>           | Exit Diagnostics  | Immediate Return to Main screen.   |
| <b>D02</b>           | Display Last Error  | Displays the last 10 recorded errors in reverse order starting with the last error recorded.<br>Up button shows next error.<br>Down button shows previous error.<br>Enter button closes function.  |
| <b>D03</b>           | Error Log   | Displays the number of occurrences of each error. Display shows Error number and Number of Occurrences. (i.e.: “ <b>05 02</b> ” means Error 5 has occurred 2 times since the error log was last cleared.)<br>Up button shows next error.<br>Down button shows previous error.<br>Enter button closes function and returns to D01.  |
| <b>D04</b>           | Clear Errors  | Clears the error log. Display will read “ <b>Cl Err</b> ”. Press enter to continue. Display will Read “ <b>Cl. No</b> ”.<br>Up arrow will select ‘clear errors’.<br>Display will read “ <b>Cl.YES</b> ”<br>Press enter to clear error log and exit the function and return to D1 or:<br>Down arrow will deselect ‘clear errors’.<br>Display will read “ <b>Cl. No</b> ”<br>Press the Enter button to execute selected option, exit the function and return to D01.   |
| <b>D05</b>           | Calibrate Temperature Probe.<br><b>Note:</b> See procedure on <a href="#">page 29</a> . | <b>Caution: Read procedure on <a href="#">page 29</a> before continuing.</b><br>Displays the cabinet temperature probe reading in tenths of a degree i.e.”-1.5°F”<br>Allows the cabinet temperature probe to be corrected.<br>Up arrow will increase temperature in 0.1° increments.<br>Down arrow will decrease the temperature in 0.1° increments.<br>Enter button will save the new setting and exit to D01.  |
| <b>D06</b>           | Read Control Probe*<br>*Used only with two probe systems.                               | Displays the refrigeration temperature controller probe reading in tenths of a degree i.e.”-8.5°F” . Displays “---“ on single probe dispensers.<br><b>Note:</b> When two temperature probes are present, one is mounted to an insulated block near the top wall of the cabinet compartment in the upper right. This probe measures cabinet temperature and is the temperature displayed on the front of the operator panel. The other probe is below the block and mounted against the back wall near the refrigeration accumulator. This probe controls the refrigeration system.<br>Enter button will exit to D01. |
| <b>D07</b>           | Control Probe Offset  | Allows the temperature control probe to be offset to adjust for any deviation from actual temperature and to allow for fine tuning of the refrigeration cycle. Default is 0°F (0°C) for single probe dispensers. Display will read “ <b>oF. 0F</b> ”. [Default is 3°F (2°C) for two probe dispensers.] Adjustable from -5°F to 15°F(-3°C to 8°C).<br>Up arrow will increase in 1° increments.<br>Down arrow will decrease in 1° increments.<br>Enter button will save the new setting and exit to D01  |

|     |   |   |
|-----|---|---|
| D08 | Reset Refrigeration Errors # 5, #6 & #7   | <p>Clears and resets any active refrigeration errors (errors 5, 6 &amp; 7)</p> <p>Display defaults to “Er. no”</p> <p>Press up arrow, display will read “Er. YES”</p> <p>Down button will return to “Er. no”</p> <p>Press enter button to execute and return to D01.</p>  |
| D09 | <p>Actuate Outputs</p> <p><b>Note:</b> Basket Size Buttons also function as numbers</p> <p><b>Note:</b> The refrigeration circuit contains anti-short-cycle protection.</p> | <p>Allows outputs to be turned on and off to aid in diagnosing problems.</p> <p>Display shows selected motor and command. (i.e. “d2 on” indicates the right drum motor’s output is on.)</p> <p>Use Basket Size Buttons to select an output:</p> <ol style="list-style-type: none"> <li>1. Left Drum motor (<b>d1</b>)--Left Small Basket</li> <li>2. Left Accumulator motor (<b>A1</b>)--Left Medium Basket</li> <li>4. Right Drum motor (<b>d2</b>)--Right Small Basket</li> <li>5. Right Accumulator motor (<b>A2</b>)--Right Medium Basket</li> <li>6. Refrigeration compressor (<b>rF</b>)--Right Large Basket</li> </ol> <p>Up arrow turns output on,<br/>Down arrow turns output off.<br/>Enter button closes function.</p> <p>The display flashing “rF OFF” indicates the refrigeration compressor cannot be restarted until the 2 minute short cycle delay is met.</p> <p>All outputs will turn off and return to normal operation when exiting the function.</p> |
| D10 | <p>Diagnostics Display</p> <p><b>Note:</b> See <a href="#">page 26</a></p>  | <p>Shows status of all controller Inputs and Outputs while the dispenser continues normal operation.</p> <p>Display shows all activated Inputs and Outputs.(see <a href="#">page 26</a>)</p> <p>Size and Enter buttons function just as in main screen during normal operation.</p> <p>Up Arrow Button does nothing.</p> <p>Down Arrow button will exit the function.</p>   |
| D11 | <p>Bypass Basket Sensors</p> <p><b>Note:</b> Volatile setting. (will reset each time power is cycled)</p>   | <p>Allows the dispenser to be used when a basket sensor has failed.</p> <p>Display will read “[bYP]” with alternating flashing brackets.</p> <p>Use Basket Size buttons to select the side to be bypassed.</p> <p>Display will default to the current sensor condition.</p> <p>Up arrow sets bypass mode. “[ YES” ( “YES”)]</p> <p>Down arrow clears it. “[ no” ( “ no”)]</p> <p>Enter button executes selection, exits function and returns to D01</p>   |
| D12 | <p>Bypass Weighing</p> <p><b>Note:</b> Volatile Setting</p>   | <p>Disable the scale to allow other diagnostics to be performed without wasting product.</p> <p>Display will read “[SCL]” with alternating flashing brackets.</p> <p>Use Size Keys to select the side to be bypassed.</p> <p>Display will default to current scale status.</p> <p>Up arrow turns the scale on for selected side.<br/> “[ on” ( “ on”)]</p> <p>Down arrow turns off the scale for selected side.<br/> “[ OFF” ( “ OFF”)]</p> <p>Enter button executes selection, exits function and returns to D01</p>   |

|                   |  |  |
|-------------------|--|--|
| <p><b>D13</b></p> | <p>Bypass Refrigeration</p> <p><b>Note:</b> Volatile Setting</p>   | <p>Allows the refrigeration system to be disabled.<br/>Display will read the current status of the refrigeration system (<b>rF on</b> or <b>rF OFF</b>).<br/>Up arrow enables the refrigeration system.<br/>Down arrow disables the refrigeration system.<br/>Enter button saves the setting, exits the function and return to D1.</p> <p><b>Note:</b> The refrigeration circuit contains anti-short-cycle protection. The refrigeration compressor cannot be restarted until the 2 minute short cycle delay is met.</p> |
| <p><b>D14</b></p> | <p>Display Scale Weight</p>  | <p>Displays the current calibrated weight on the scale.<br/>Display will read “[SCL]” with alternating flashing brackets.<br/>Use Size Buttons to select the side to be displayed.<br/>Enter Button exits function and returns to D01</p>  |
| <p><b>D15</b></p> | <p>Display Scale Volts</p>   | <p>Displays the current uncalibrated input from the scale.<br/>Display will read “[SCL]” with alternating flashing brackets.<br/>Use Size Buttons to select the side to be displayed.<br/>Enter Button exits function and returns to D01</p>   |
| <p><b>D16</b></p> | <p>Exercise Mode</p> <p><b>Note:</b> Volatile Setting</p> <p><b>Caution:</b> Ensure the hopper is empty before using Exercise Mode</p> | <p>Exercise mode is designed to “break in” a replaced component. When the dispenser is in exercise mode, the selected side(s) will continuously cycle.</p> <p>Display will read “[E-]” with alternating flashing brackets.<br/>Use Size Buttons to select the side to be exercised.<br/>Up arrow selects exercise mode:<br/>Display reads “[ on]” (“ on”)<br/>Down arrow clears exercise mode.<br/>Display reads “[ OFF]” (“ OFF”)<br/>Enter button executes selection and exits to D01</p>                              |
| <p><b>D17</b></p> | <p>Restore Defaults</p>  | <p>Restores all settings to factory defaults<br/>Display defaults to “rd. no”<br/>Up arrow will select restore defaults:<br/>Display reads “rd.YES”<br/>Down arrow will deselect restore defaults.<br/>Display will read “rd. no”<br/>Enter button will execute selection and exits to D01</p> <p><b>Caution: This function will erase scale calibrations, temperature probe calibrations, changes to target weights, temperature setpoint, alarm setpoint, and will reset passwords to defaults.</b></p>                |
| <p><b>D18</b></p> | <p>Power Volts</p>   | <p>Displays the current power supply voltage.<br/>Enter Button exits the function and returns to D01</p>   |

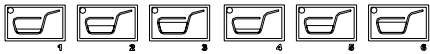
- Use the Up  and Down  Arrow Buttons to find the desired function.
- Press the Enter  Button to select the desired function.
- Basket Size Buttons also function as numbers: 

(Left Small=1, Left Medium=2, Left Large=3, Right Small=4, Right Medium=5, Right Large=6)

Service Password to access both the Manager Menu and Diagnostic Menu: 22463

**Note: Using the Service Password to access the Manager Function menu will erase the manager’s password (if set) and restore it to default (no password).**



## Error Detection

The main display and Basket Size Button LED lights will flash with the detection of an error condition for the effected side. The display will state the error that has occurred. (i.e. “**Err 4**”)

If an error does occur, it is normally reset by pushing the Enter  Button. If the failure continues, turn the Power Switch off and unplug the Power Cord from the wall outlet. Check the Power Cord for any obvious defect. Open the Cabinet Door to make sure the dispenser is properly assembled ([pages 6-11](#)) and the product is loaded properly.

See [pages 24-26](#) for troubleshooting an error condition.

| Error Codes |  |
|-------------|--|
| Error       | Description  |
| 01          | Timeout error on left accumulator.                   |
| 02          | Timeout error on right accumulator.                  |
| 03          | Left Tare weight has shifted excessively.            |
| 04          | Right Tare weight has shifted excessively.           |
| 05          | Refrigeration progress too slow. (>25°F for 1.75 Hr) |
| 06          | Refrigeration High Pressure Switch has tripped.      |
| 07          | Error on refrigeration relay drive.                  |
| 08          | Temperature Probe input out of range.                |
| 09          | Invalid data in Configuration (normal first time)    |
| 10          | Internal System Error                                |

**Note: Errors 5, 6 & 7 are refrigeration errors.** These errors, while requiring corrective action, will not disable the fry dispensing portions of the equipment. In order to safeguard the refrigeration system these are hard errors and may not reset by pushing the Enter  Button. These errors are reset from the Diagnostic Menu using Diagnostic Function **D08**.

Call our Technical Support Hot Line for assistance with these errors.

## Troubleshooting

The following is a list of errors that may occur, probable causes, and corrective action that may eliminate the problem. If, after performing the corrective action, the problem persists, call our Technical Support Hotline for assistance.

Our Technical Support Hotline is available for telephone assistance providing product technical support, parts and parts information, and service agent referral.

**Technical Support Hot Line: 1-800-248-2724 (U.S./Canada) or 651-385-2273.**

**Error 1** The controller has detected a TIMEOUT ERROR FOR THE LEFT ACCUMULATOR MOTOR HOME SENSOR. The accumulator home encoder sensor sends an input to the controller each time the accumulator doors cycle. It lets the controller know that the doors opened and closed in an acceptable time. A timeout error will occur if the following conditions are not detected. Accumulator home switch timeouts:

- If it starts in the home area, it must leave it within 0.5 seconds.
- Once it is clear, it will make a half turn, then pause.
- When it has resumed from the pause, it must find the home area within 2.0 seconds.

A Timeout Error could be caused by an accumulator motor fault, broken accumulator linkage, a disconnected or faulty accumulator encoder or a damaged encoder vane. Verify the accumulator encoder wiring at both the board and at the encoder is secure and the vane is in place and undamaged. Check accumulator linkage to ensure it is undamaged.

**Error 2** The controller has detected a TIMEOUT ERROR FOR THE RIGHT ACCUMULATOR MOTOR HOME SENSOR. The accumulator home encoder sensor sends an input to the controller each time the accumulator doors cycle. It lets the controller know that the doors opened and closed in an acceptable time. A timeout error will occur if the following conditions are not detected. Accumulator home switch timeouts:

- If it starts in the home area, it must leave it within 0.5 seconds.
- Once it is clear, it will make a half turn, then pause.
- When it has resumed from the pause, it must find the home area within 2.0 seconds.

A Timeout Error could be caused by an accumulator motor fault, broken accumulator linkage, a disconnected or faulty accumulator encoder or a damaged encoder vane. Verify the accumulator encoder wiring at both the board and at the encoder is secure and the vane is in place and undamaged. Check accumulator linkage to ensure it is undamaged.

**Error 3** The controller has detected a LARGE SHIFT IN THE TARE (EMPTY) READING FOR THE LEFT SIDE'S SCALE INPUT. Could be caused by an obstruction of the scale or lose of calibration. Verify the accumulator housings and flap doors are properly assembled. Check accumulator doors to ensure there are no obstructions (i.e. fries jammed underneath). Verify the shaft collars are not rubbing the back wall of the cabinet. If no obstruction is found calibrate the scale. ([Page 27](#))

**Error 4** The controller has detected a LARGE SHIFT IN THE TARE (EMPTY) READING FOR THE RIGHT SIDE'S SCALE INPUT. Could be caused by an obstruction of the scale or lose of calibration. Verify the accumulator housings and flap doors are properly assembled. Check accumulator doors to ensure there are no obstructions (i.e. fries jammed underneath). Verify the shaft collars are not rubbing the back wall of the cabinet. If no obstruction is found calibrate the scale. ([Page 27](#))

**Troubleshooting cont.**

- Error 5** The controller has detected that the CABINET TEMPERATURE IS NOT COOLING AS EXPECTED. Likely causes are leaving the cabinet door open for extended periods of time during operation or the power was left on while defrosting the cabinet. Other possible causes are a restriction to the air flow across the condensing unit such as might occur with a dirty or plugged condenser filter and/or coil, an improperly positioned temperature probe or a malfunction of the refrigeration compressor. Check for obstructions near the condensing unit inlet grill and inspect and clean the condenser filter and/or coil if needed. ([page 40](#)) Verify the temperature probes are in place and properly secured to their mounting brackets. CALL OUR TECHNICAL SUPPORT HOTLINE FOR ASSISTANCE. † (see note below to reset error)
- Errors 6** The HIGH PRESSURE SWITCH FOR THE REFRIGERATION SYSTEM HAS TRIPPED. Possible causes include a restriction to the air flow across the condensing unit such as might occur with a dirty or plugged condenser filter and/or coil. Check for obstructions near the condensing unit inlet grill. Inspect and clean the condenser filter and/or coil if needed ([page 40](#)). A failed refrigeration over pressure switch, or a loose wire to the over pressure switch could cause this error. A failed feedback relay or a loose wire to the feedback relay can cause this error. Finally a very short duration power outage can cause this error. CALL OUR TECHNICAL SUPPORT HOTLINE FOR ASSISTANCE. (**WARNING: HIGH VOLTAGE. Unplug the dispenser before attempting to repair the wiring for the high pressure switch.**) † (see note below to reset error)
- Errors 7** The controller has detected an ERROR ON THE REFRIGERATION RELAY DRIVE indicating the compressor feedback relay did not turn off when the controller turned off refrigeration. This could be caused by a stuck refrigeration relay, the feedback relay stuck shut, a short circuit, or controller output failure. Verify there is no foreign material or loose connections around the relay output. † (see note below to reset error)
- Error 8** The controller has determined an INPUT FROM THE CABINET OR REFRIGERATION CONTROL TEMPERATURE PROBE IS OUT OF RANGE HIGH OR LOW. The most likely cause is a failed or disconnected temperature probe. Verify the temperature probes wires are properly secured at the controller board.
- Error 9** NVRAM CHECKSUM ERROR. The controller has detected invalid or corrupt data. **It is normal to get this error the first time a dispenser is powered on after a new processor has been installed or replaced.** The data may be invalid for several reasons. The processor writes the permanent data (error logs, configuration, and operating parameters) along with extra data that it uses to verify the data is valid. If the error persists it likely indicates a failure of the NVRAM. CALL OUR TECHNICAL SUPPORT HOTLINE FOR ASSISTANCE.
- Error 10** An INTERNAL SYSTEM ERROR HAS OCCURRED. This error could occur for various reasons including electrical interference, an error in the dispensers software or a fault in the processor. CALL OUR TECHNICAL SUPPORT HOTLINE FOR ASSISTANCE.

†**Note: Errors 5, 6 & 7 are refrigeration errors.** These errors, while requiring corrective action, will not disable the fry dispensing portions of the equipment. In order to safeguard the refrigeration system these are hard errors and may not reset by pushing the Enter  Button. Call our Technical Support Hot Line for assistance with Errors 5, 6 & 7. These errors are reset from the Diagnostic Menu using Diagnostic Function **D08**.

**For Warranty Service & Technical Support call:**

**US & Canada: 1 (800) 248-2724**

**International: 1 (651) 385-2273**

After hours, your call will be handled by a voice mail paging service. The on call technician will be paged and will return your call.

**Troubleshooting cont.**

**Using the Diagnostic Display (D10):**

Function D10 allows the user to see the status of all controller inputs and outputs on the main screen while continuing to use the dispenser. As inputs and outputs turn on and off their corresponding segment will also turn on and off. The diagram below identifies which segment on the display will light for each input and output.

The user can continue to use both sides of the dispenser while in this function. If an error condition occurs while in the function it can still be reset by pressing the Enter  Button on the operator panel.

This function is especially useful for checking basket sensor and accumulator home switch status. It will also allow a technician to determine when the dispenser is calling for each side's drum and accumulator motors to run and when the refrigeration compressor should be running.

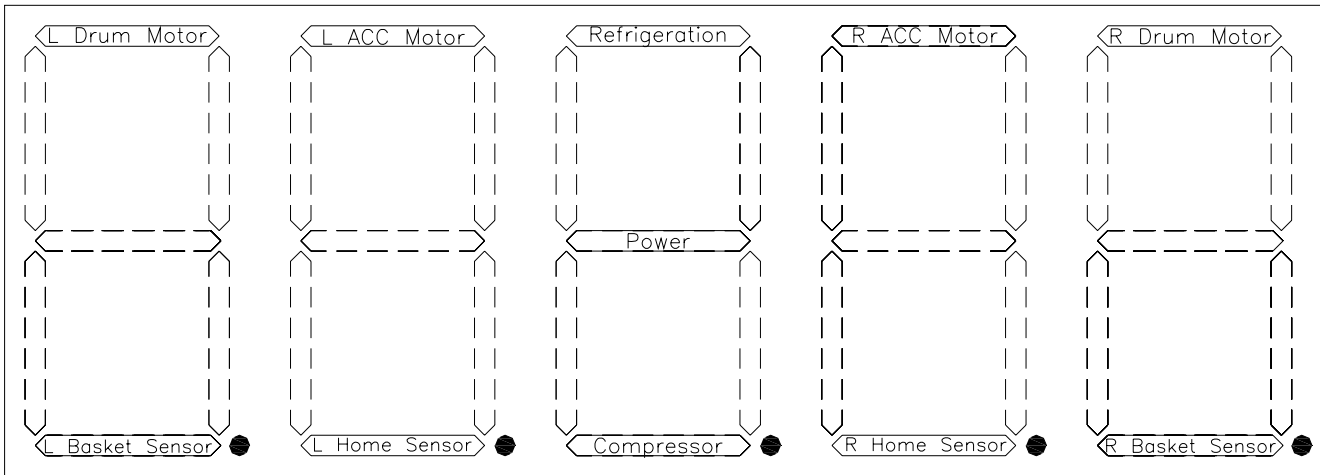

- L Drum Motor lit: The controller is calling for the left drum motor to run.
- L Basket Sensor lit: The left basket sensor has detected a basket.
- L Acc Motor lit: The controller is calling for the left accumulator motor to run.
- L Home Sensor lit: The left accumulator encoder sensor has detected the home position.
- Refrigeration lit: The controller is calling for the refrigeration compressor to run.
- Power lit: The controller is turned on. Mainly used as a reference light.
- Compressor lit: The refrigeration compressor is running.
- R Acc Motor lit: The controller is calling for the right accumulator motor to run.
- R Home Sensor lit: The right accumulator encoder sensor has detected the home position.
- R Drum Motor lit: The controller is calling for the right drum motor to run.
- R Basket Sensor lit: The right basket sensor has detected a basket.

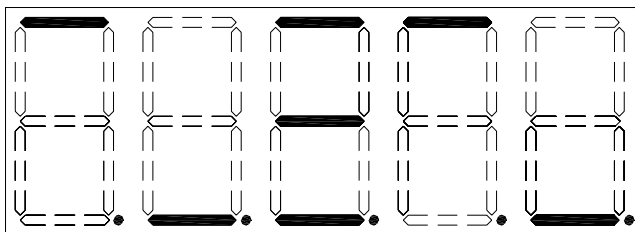

Example

The example displayed left indicates the following inputs/outputs are on:

- Left Drum Motor
- Left Home Sensor
- Refrigeration
- Power
- Compressor
- Right Acc Motor
- Right Basket Sensor

## Calibrations and Adjustments



### Scale Calibration

The RAM 280-F Frozen Fry Dispenser will maintain and dispense fries from two hoppers. Each side has a scale which weighs and dispenses frozen fries independent of one another. These scales may require calibration periodically.

1) Open the cabinet door and remove the hopper from the dispenser for the side to be calibrated.

**Note: The accumulator housing(s) should remain in place on the accumulator doors.**

Calibration of the scales is performed using the operator panel on the front of the Dispenser.

2) Press the Up Arrow  Button until "U2" is displayed then press the Enter  Button. The display will change to "[CAL]" ("[--]" metric) with flashing brackets alternating from left to right.

3) Select the side to be calibrated by pressing a Basket Size  Button on the side to be calibrated. The display will change to "[ --]" if the left side's scale is selected or "-- ]" if the right side's scale is selected.

4) Place an empty fry basket under the accumulator doors for the side to be calibrated. Lift the front of the basket slightly and slide the basket forward over the window for the basket sensor. The accumulator doors will open and close to dispense any contents into the basket to ensure the Accumulator Housing is empty before zeroing the scale.

5) The display will change to "0.0". The scale now tares (zeros) itself automatically.

6) After it achieves a stable tare the display will change to "1.0" or "450" in metric. Place a 1 lb (450 g) reference weight on the accumulator doors for the side to be calibrated. (Note: Four frozen ¼ lb patties can be used in place of a 1 lb reference weight.)

7) Once the scale stabilizes the display will change to "2.0" or "900" in metric. Place a 2 lb (900 g) reference weight (an additional 1 lb (450 g)) on the accumulator doors for the side to be calibrated.

8) After the scale stabilizes the display will change to "---". Remove the reference weight(s) from the accumulator doors and reinstall the hopper for the side that was calibrated.

9) Close the cabinet door.



The dispenser will return to normal operation with no basket size selected for the side that was calibrated.

10) Repeat for the opposite side's scale if required

### Set Manager Password

A password can be set to restrict unauthorized access to both the Manager and Diagnostic Function Menus. Once set, the password will need to be entered to gain access to restricted menus. Take care to remember your password or write it down and keep it in a safe location.

A manager password is set and/or changed from the Manager Function Menu ([page 19](#)) using the operator panel on the front of the dispenser and requires the current manager's password (if set) to access the menu.



To access the Manager Function Menu and set or change the manager password, press the Up Arrow  Button until "U3" is displayed then press the Enter  Button.

If a password is required the display will change to "----" Enter the managers password (if set) using the basket size buttons. Then press the Enter  button.

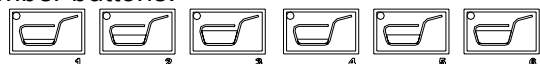
**Note:** The Basket Size Buttons also function as number buttons:



(e.g. the left medium basket button is number 2, and the right large basket button is number 6.)

The display will change to "F1". Press the Up Arrow  Button until "F6" is displayed then press the Enter  Button. The display will change to "----" Enter a manager password using the basket size buttons. As the password is entered the dashes in the display will move from the bottom segments to the middle segments, i.e. "---\_" Press the Enter  button to save the password.

**Note: The password must be entered twice (double entry).**

If successful the display will change to "F1". Press the Enter  Button to exit to the Main Screen and return to normal operation.

## **Target Weight Adjustment**

Each Basket Size Button's Target Weight can be individually customized.

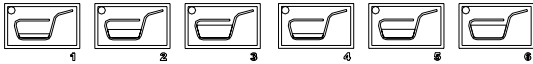

Default settings are:

- Small load = 0.50 LBS(225 gr)
- Medium load = 1.0 LBS(450 gr)
- Large load = 1.5 LBS(700 gr)

**Note:** Adjustments to the target weight for basket size buttons are performed from the Manager Function Menu ([page 19](#)) using the operator panel on the front of the dispenser and may require a manager's password to access the menu.

To access the Manager Function Menu and customize the Target Weights for the Basket Size Buttons press the Up Arrow Button until "U3" is displayed then press the Enter Button.

If a password is required the display will change to "-----" Enter the managers password (if set) using the basket size buttons. Then press the Enter button.

**Note:** The Basket Size Buttons also function as number buttons:

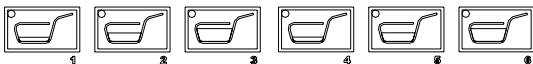

(e.g. the left medium basket button is number 2, and the right large basket button is number 6.)

The display will change to "F1". Press the Up Arrow Button until "F2" is displayed then press the Enter Button.

The display will default to the Left Small Basket Button's current Target Weight. (i.e. "0.50Lb").

Select and press the Basket Size Button to be customized.

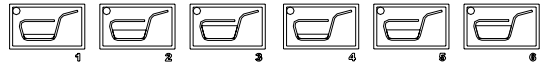

An LED light will illuminate next to the currently selected Basket Size Button and the display will read the current target weight assigned for the button.

To change the target weight for the currently selected Basket Size Button, press the Up Arrow Button to increase the target weight in 0.05 LB increments (25gr), or the Down Arrow Button to decrease the target weight.

Repeat until all adjustments have been made. Press the Enter Button to store the new settings and close the function.

The display will read "d01". To exit to the Main Screen and return to normal operation press the Enter Button.

## Temperature Probe Calibration

The RAM 280-F Frozen Fry Dispenser has used two different temperature control configurations, one using a single probe and the other a two probe configuration. The single probe configuration, serial number LONR0903C00692 and going forward, uses a single temperature probe mounted to an insulated block on the top wall of the cabinet compartment in the upper right. It is the temperature displayed on the control panel and also used to control the refrigeration system.

The two probe configuration, serial numbers LONR0903C00691 and earlier, has one probe mounted to an insulated block on the top wall of the cabinet compartment in the upper right. This probe measures cabinet temperature and is the temperature displayed on the front of the operator panel. The other probe is below the block and mounted against the back wall near the refrigeration accumulator. This probe controls the refrigeration system.

The temperature control is factory set. Unless the controller or the temperature probe(s) are replaced, it will not be necessary to change these values. In addition, raising or lowering the set point temperature can compensate for small discrepancies between the probe temperature and actual temperature. However, differences of greater than 2° should be corrected. The method for adjusting the temperature probe is simple, but requires an accurate thermometer (preferably certified) to measure the probes deviation from the actual temperature:



Place the thermometer into the freezer compartment as close to the cabinet temperature probe as practical. The machine should be operating at or near normal operating temperature, -2°F to 10°F (-19°C to -12°C). If the thermometer has a sensing probe, make certain that it is not touching any metal in the compartment, otherwise it may give a false reading.

Wait 5 minutes with the dispenser operating normally and the door closed.

Check the thermometer reading and compare it with the temperature displayed on the operator panel. The best time to check is just after the compressor shuts off.

If the difference between the display and the thermometer is greater than 2°, an adjustment should be made.

**Note:** Calibration of the temperature probe is performed from the Diagnostic Functions Menu using the Operator Panel on the front of the Dispenser and may require a manager's password to access the menu.



To access the Diagnostics Menu, on the Operator Panel, press the Up Arrow  Button until "U4" is displayed then press the Enter  button.

The display will change to "...." Enter the managers password (if set) using the basket size buttons. Then press the Enter  button.

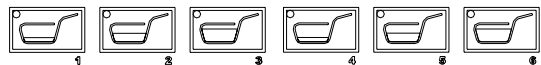

**Note:** The Basket Size Buttons also function as number buttons:





(e.g. the left medium basket button is number 2, and the right large basket button is number 6.)

The display will change to "d01". Press the Up Arrow  button until "d05" is displayed then press the Enter  button to access the Probe Calibration Function.

The display will read the current cabinet temperature the probe is detecting.

Adjust the probe temperature to match the correct temperature using the Up Arrow  button to raise the displayed temperature or the Down Arrow  button to lower the displayed temperature. (Note: each time an arrow button is pressed will change the temperature 0.1°).

Once the displayed temperature matches the thermometer temperature press the Enter  button to save the calibration and exit the function.

The display will read "d01". To return to the main screen press the enter  button.



## Part Identification

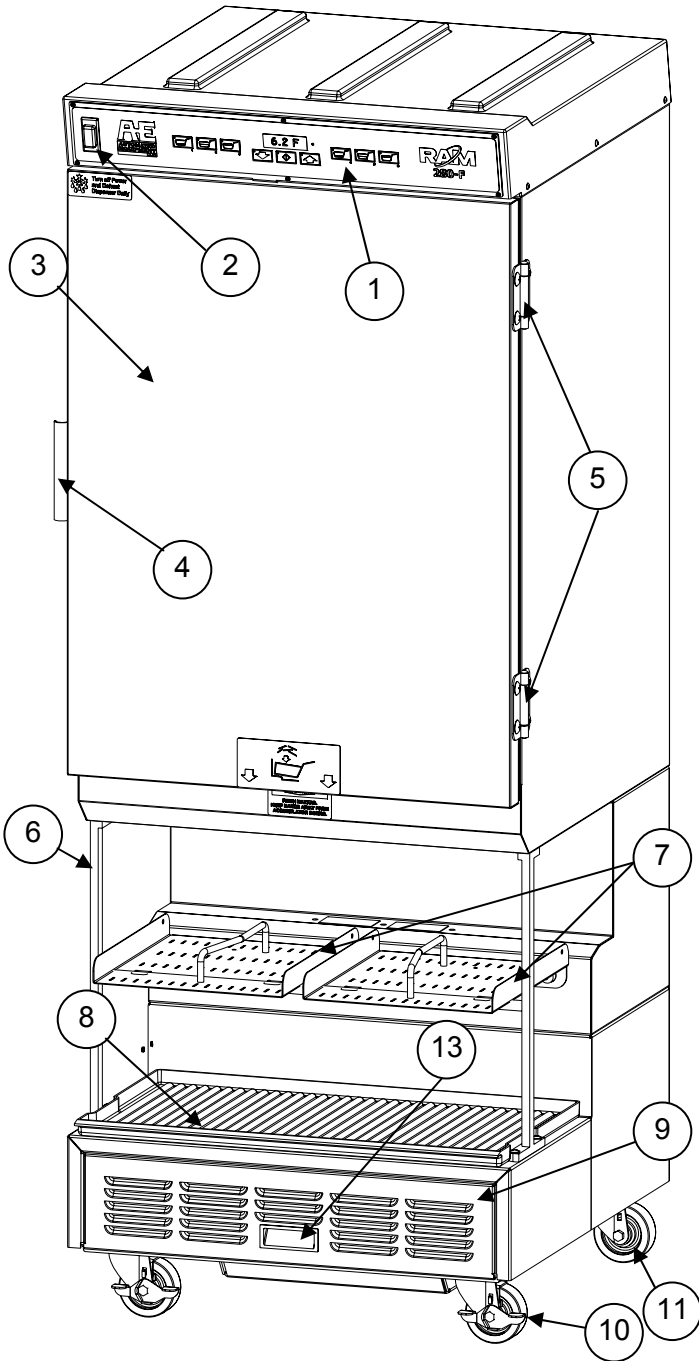

| Item | Qty    | Part #            | Description  |
|------|--------|-------------------|--|
| 1    | 1      | 294401            | Kit: Operator Panel  |
|      |        | 294007            | Kit, Operator Panel (w/metal door switch tab)                  |
|      | 1      | 293789            | Gasket (Faceplate)   |
|      | 6      | 294051            | Screw, pan-head, Phillips, #6-32x1/2"                          |
|      | 2      | 292246            | On/Off Switch 15A  |
|      | 3      | 1                 | 293195   |
| 1    |        | 293189            | Door Gasket  |
| 4    | 1      | 293197            | Handle, Door   |
|      | 2      | 202077            | Screw, Truss Head, slotted, 1/4-20x1/2"                        |
| 5    | 2      | 293706            | Hinge, Door  |
|      | 4      | 293855            | Screw, Truss Head, Phillips, 3/8-16x1/2"                       |
| 6    | 2      | 293253            | Support Bar, Cabinet   |
|      | 6      | 213571            | Screw, Truss Head, slotted, 1/4-20x 3/4"                       |
| 7    | 1      | 294022            | Right Basket Tray  |
|      | 1      | 294147            | Left Basket Tray   |
|      | 4      | 290687            | Locator Pin  |
|      | 2      | 294021            | Guide Bar  |
|      | 4      | 290000            | Screw, Truss Head Slotted, 10-32x1/2"                          |
| 8    | 1      | 294821            | Drip Tray (with extended front)                                |
|      |        | 293590            | Drip Tray  |
| 9    | 1      | 294750            | Panel, Filter Access, Louvered ( <a href="#">see page 40</a> ) |
|      | 2      | 291158            | Screw, Thumb   |
|      | 2      | 294803            | Retainer, Thumb Screw  |
|      | 1      | 294751            | Frame, Filter Access Panel                                     |
|      | 1      | 293716            | Drawer Assm., Louvered ( <a href="#">see page 40</a> )         |
|      | 4      | 293710            | Washer, shoulder, Nylon  |
|      | 4      | 290012            | Hex Nut 5/16-18  |
| 1    | 293512 | Filter, Condenser |  |
| 10   | 2      | 216596            | Caster, Front Locking  |
|      | 4      | 200766            | Screw, Hex-Head 5/16-18x 1"                                    |
|      | 4      | 200774            | Screw, Hex-Head 5/16-18x3/4"                                   |
| 11   | 2      | 216595            | Caster, Rear   |
|      | 8      | 200774            | Screw, Hex-Head 5/16-18x3/4"                                   |
| 12   |        | 291050            | Basket, Fry, Black Handle                                      |
|      |        | 294008            | Case of 8 Fry Baskets  |
| 13   | 1      | 202523            | Handle, Filter Drawer  |
|      | 1      | 294410            | Label Kit  |

**Dispenser Cabinet Assembly  
(Front View)**

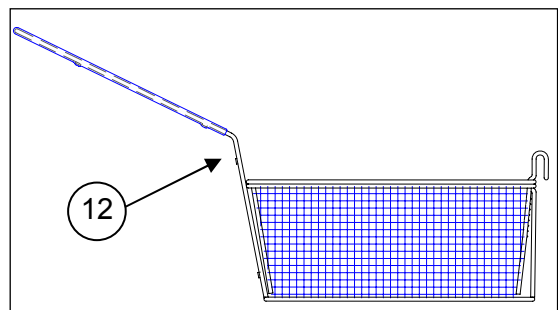



**Parts Identification Cont.**

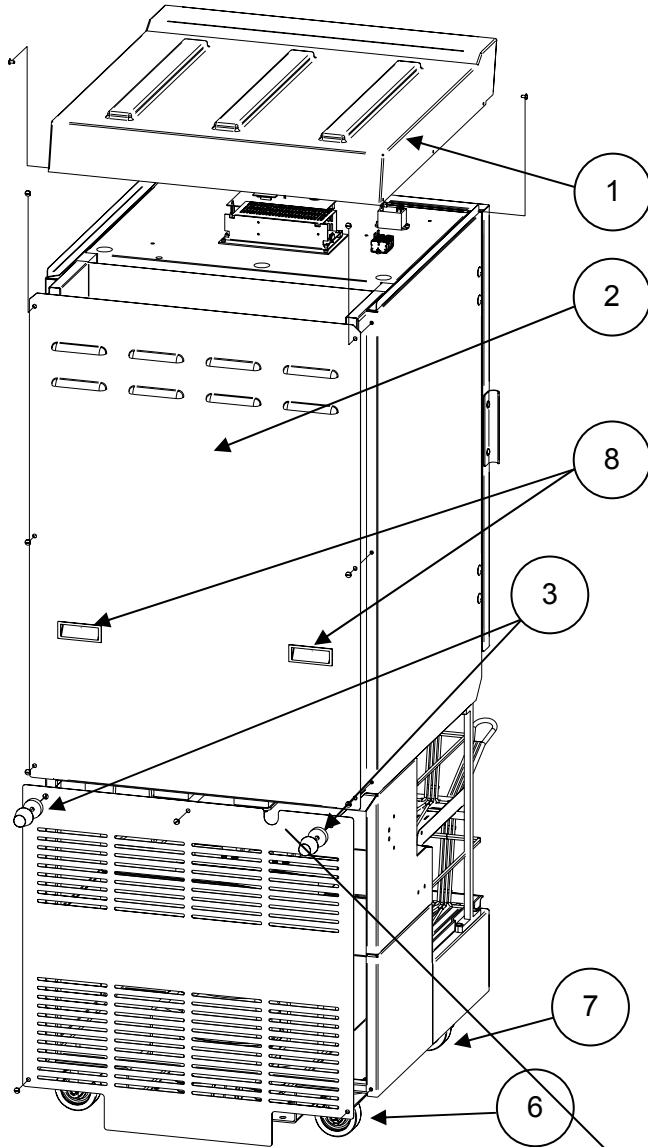

| Item | Qty | Part # | Description  |
|------|-----|--------|--|
| 1    | 1   | 293899 | Top Cover  |
|      | 6   | 294092 | Screw, pan head, Phillips 8-18x3/8"                        |
|      | 2   | 293795 | Rail, cover mounting                                       |
|      | 4   | 213262 | Screw, socket head 10-32x3/8"                              |
| 2    | 1   | 293928 | Upper Back Panel with handles                              |
|      | 6   | 294824 | Screw, Truss Head, Slotted, Pelleted, 18-8 SS, 10/32x 3/8" |
| 3    | 2   | 290070 | Bumper, Wall   |
|      | 2   | 290085 | Spacer, Wall Bumper  |
| 4    | 1   | 293929 | Lower Back Panel with handles                              |
|      | 3   | 294824 | Screw, Truss Head, Slotted, Pelleted, 18-8 SS, 10/32x 3/8" |
| 5    | 1   | 293399 | Domestic U.S. Power Cord                                   |
|      | 1   | 294129 | International (Euro) Power Cord                            |
|      | 1   | 216692 | Strain Relief w/ Elbow                                     |
|      | 1   | 213942 | Nut, lock, 1/2" conduit                                    |
| 6    | 1   | 202586 | Washer, Flat, Nylon 7/8"x1 1/8"x1/16"                      |
|      | 2   | 216595 | Caster, Non-Lock (rear)                                    |
|      | 8   | 200774 | Screw, Hex-Hd Cap 5/16-18x3/4"                             |
|      | 2   | 216596 | Caster, Locking, (front)                                   |
| 7    | 4   | 200776 | Screw, Hex-Hd Cap 5/16-18x1"                               |
|      | 4   | 200774 | Screw, Hex-Hd Cap 5/16-18x3/4"                             |
|      | 4   | 202523 | Handle, Snap In  |
| 8    | 1   | 294410 | Label Kit  |

**Dispenser Cabinet (rear view)**  
For models prior to s/n 28FR0710A00153

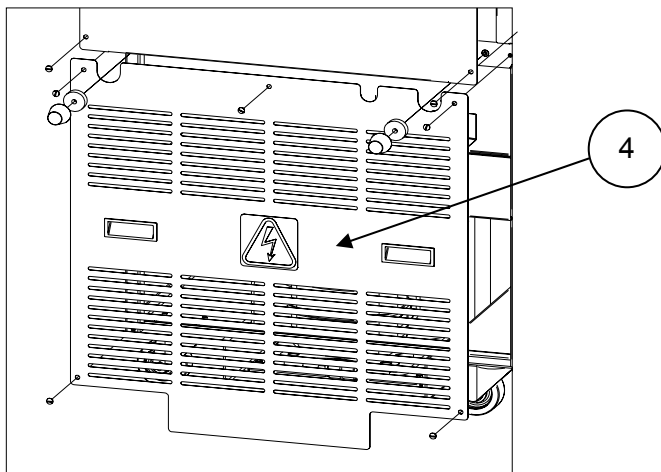

**Lower Back Panel**  
For models after and including s/n 28FR0710A00153

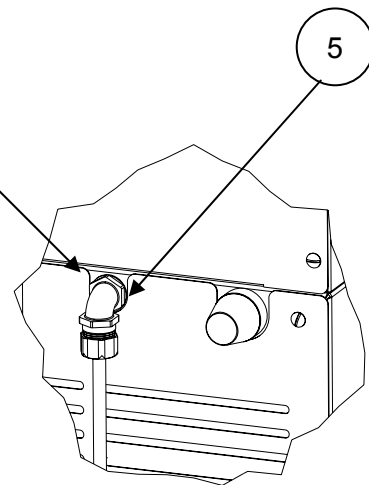

Parts Identification Cont.

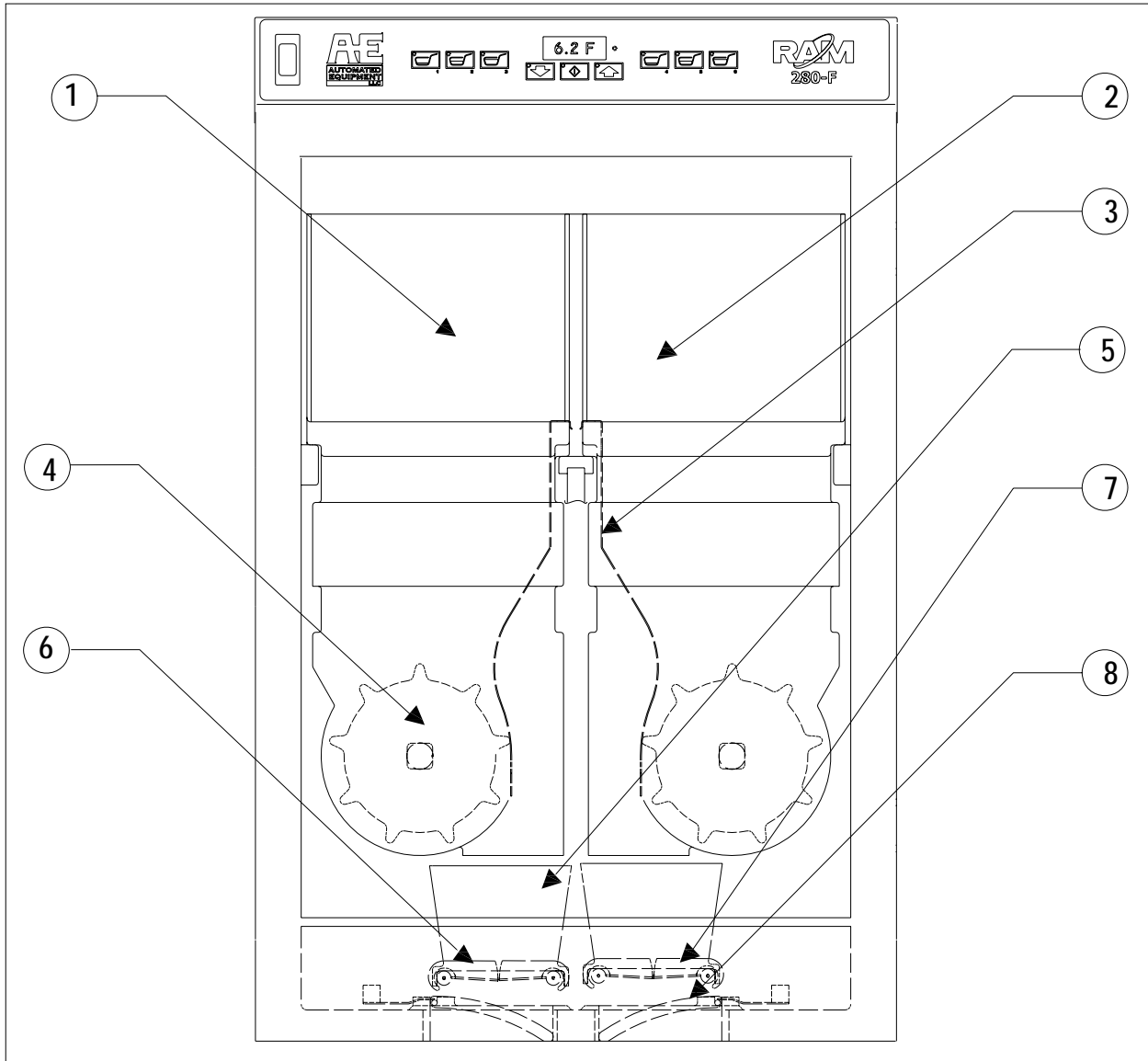

**Hopper Components**

| Item | Qty | Part#            | Description   |
|------|-----|------------------|---|
| 1    | 1   | 294397           | Hopper, 30lb, Left (replaces pn 293140)   |
| 2    | 1   | 294396           | Hopper, 30lb, Right (replaces pn 293139)  |
| 3    | 2   | 293329           | Diverter, Fry   |
| 4    | 2   | 202366           | Drum, High Tolerance  |
| 5    | 2   | 293141<br>294416 | Housing, Accumulator (Units prior to sn 28FR0802B0249)<br>Housing, Accumulator (Units after and including sn 28FR0802B00249)  |
| 6    | 2   | 293738<br>294409 | Door, Accumulator, LH (Units prior to sn 28FR0802B0249)<br>Door Accumulator LH (Units after and including sn 28FR0802B00249)  |
| 7    | 2   | 293737<br>294391 | Door, Accumulator, RH ( Units prior to sn 28FR0802B0249)<br>Door Accumulator RH (Units after and including sn 28FR0802B00249) |
| 8    | 2   | 293376           | Door, Flap  |

Part Identification Cont.

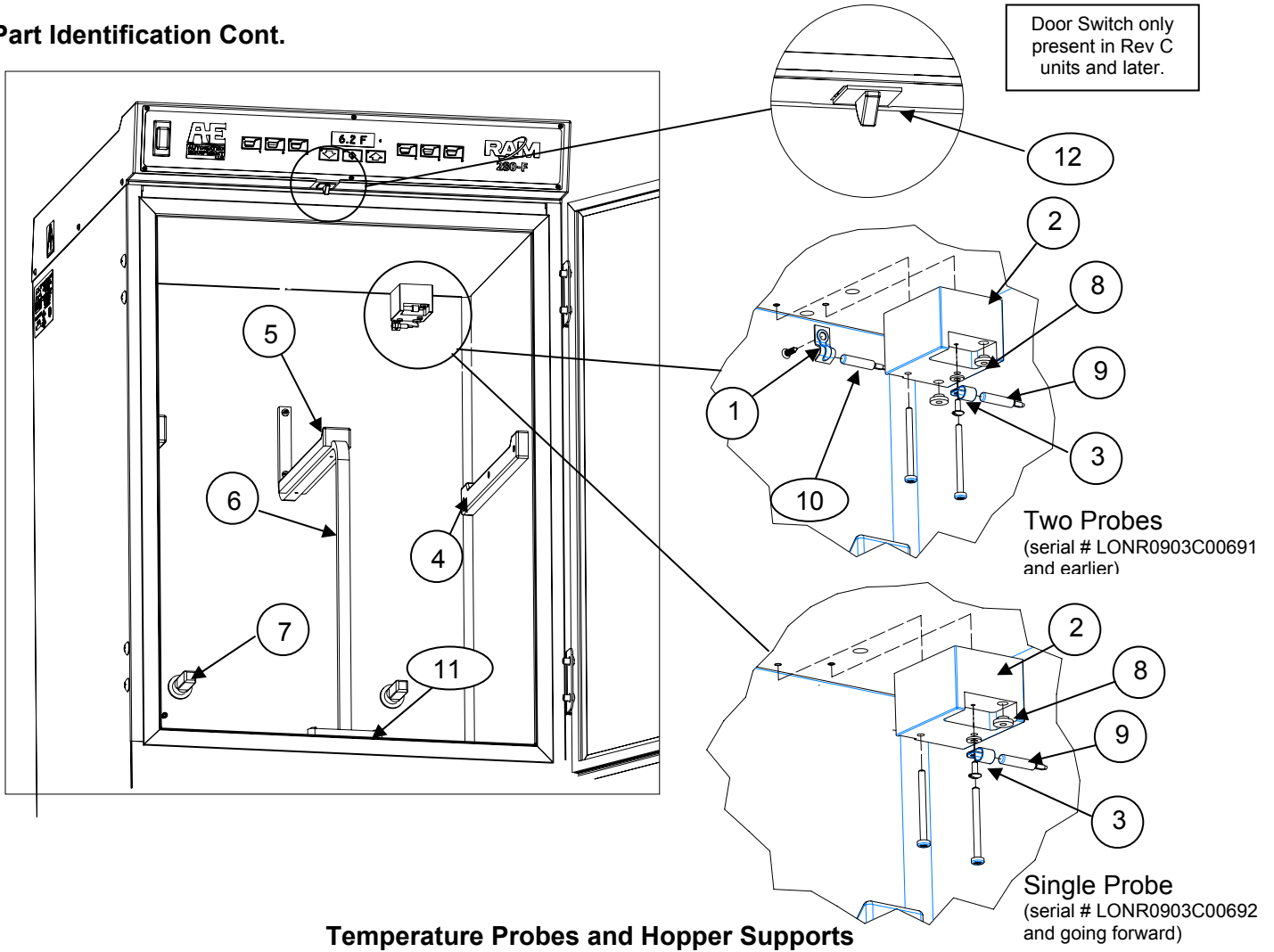

Temperature Probes and Hopper Supports

| Item | Qty | Part#  | Description                                | Item | Qty | Part#  | Description                        |
|------|-----|--------|--|------|-----|--------|------------------------------------|
| 1    | 1   | 293719 | Clamp, Refrigeration Control Probe         | 6    | 1   | 293259 | Hopper Support Bar, Center         |
|      | 1   | 293940 | Screw #6x1/2" sheet metal screw            |      | 2   | 213561 | Screw, Truss-head, SS, #10-32x3/4" |
| 2    | 1   | 293688 | Probe Mounting Block                       | 7    | 2   | 202895 | Bearing, Drum Shaft                |
|      | 2   | 294714 | Screw, Pan-head, Phillips, SST, #8-32X2"   |      |     |        |                                    |
| 3    | 1   | 291284 | P-clip, Cabinet Temperature Probe          | 8    | 2   | 292058 | Bushing, Rubber, Cable Protector   |
|      | 1   | 293566 | Spacer                                     | 9    | 1   | 293410 | Probe, Cabinet Temperature         |
|      | 1   | 293677 | Screw, Truss-head, slotted, SS #6-32x 3/8" | 10   | 1   | 293785 | Probe, Refrigeration Control       |
| 4    | 2   | 293257 | Hopper Support, Sidewall (Left or Right)   | 11   | 1   | 293650 | Gasket, Hopper Support Bar         |
|      | 6   | 293720 | Screw, Flat-head, slotted, SS #10-32x 1"   |      |     |        |                                    |
| 5    | 1   | 293260 | Hopper Support Pad, Center                 | 12   | 1   | 294407 | Door Switch                        |
|      | 4   | 293720 | Screw, Flat-head, slotted, SS #10-32x 1"   |      | 1   | 294408 | Door Switch Harness                |

**Part Identification Cont.**

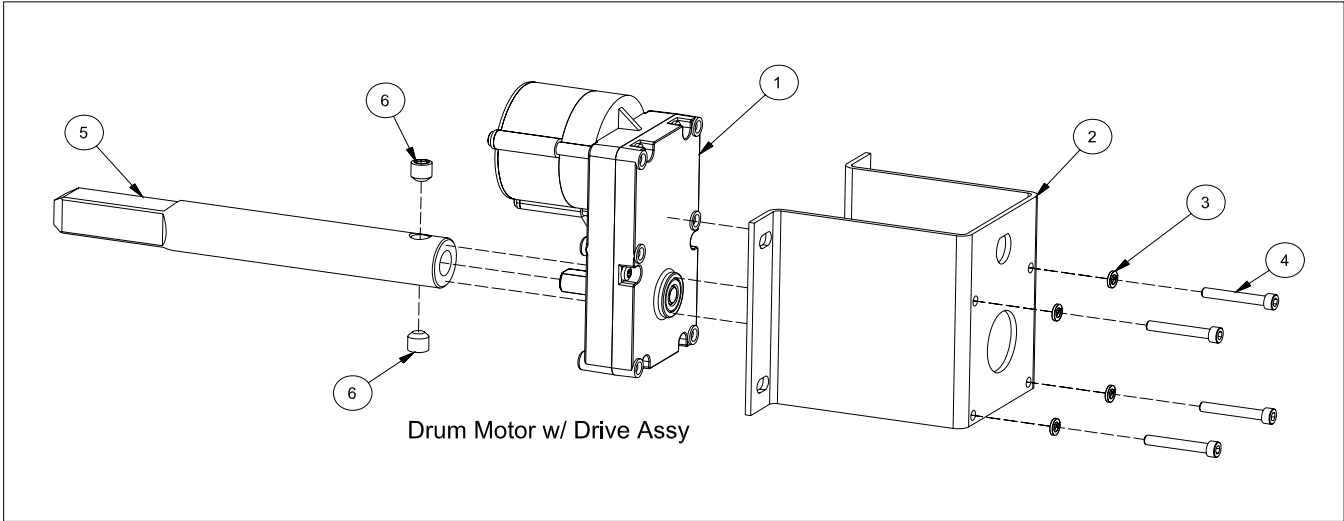

**Drum Motor Assembly**

| Item | Qty | Part#  | Description                    | Item | Qty | Part#  | Description                      |
|------|-----|--------|--------------------------------|------|-----|--------|----------------------------------|
| 1    | 1   | 292546 | Motor, Gear, Brushless, 24 VDC | 4    | 4   | 213136 | Cap Screw, Socket HD, #10-32x1¼" |
| 2    | 1   | 202797 | Bracket, Mount, Drum motor.    | 5    | 1   | 293318 | Drum Shaft, 280F                 |
| 3    | 4   | 213140 | Washer, Lock, #10              | 6    | 2   | 290653 | Set Screw, 3/8"-24 x 3/8"        |

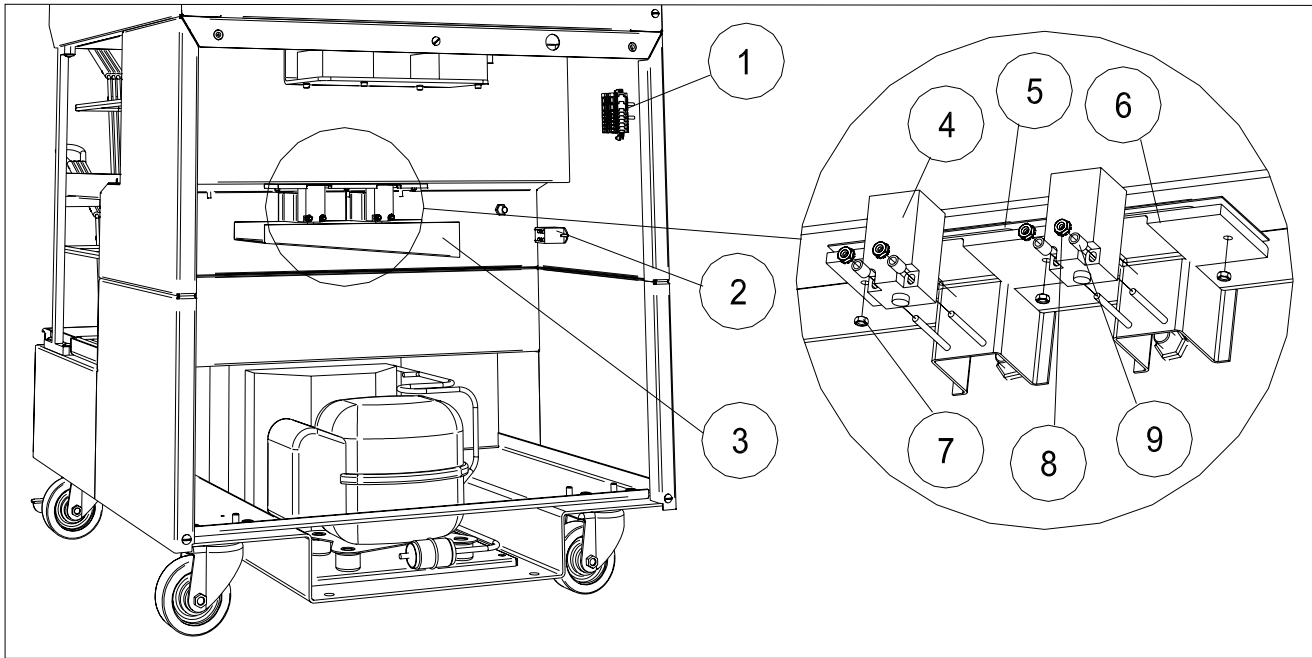

**Basket Sensor Assembly**

| Item | Qty | Part#            | Description   | Item | Qty | Part#            | Description   |
|------|-----|------------------|---|------|-----|------------------|---|
| 1    | 1   | 293404           | Terminal Block (lower)                                      | 7    | 3   | 205219           | Nut, Hex #8-32 SS.  |
| 2    | 1   | 293734<br>293974 | Feedback Relay (Domestic)<br>Feedback Relay (International) | 8    | 4   | 202874           | Nut Hex #6-32w/ Ext lock washer   |
| 3    | 1   | 294018           | Drip Pan Assembly w/ tape                                   | 9    | 4   | 293731           | Spacer, Nylon, ¼"x#8x3/8"   |
| 4    | 2   | 293934           | Basket Sensor   | 10   | 1   | 293415<br>294261 | Accumulator Heater Wire Domestic<br>Accumulator Heater Wire Int. 220V<br>(not pictured) |
| 5    | 1   | 293707           | Gasket, Sensor Window                                       |      |     |                  |   |
| 6    | 1   | 294593           | Sensor Window Kit   |      |     |                  |   |

Part Identification Cont.

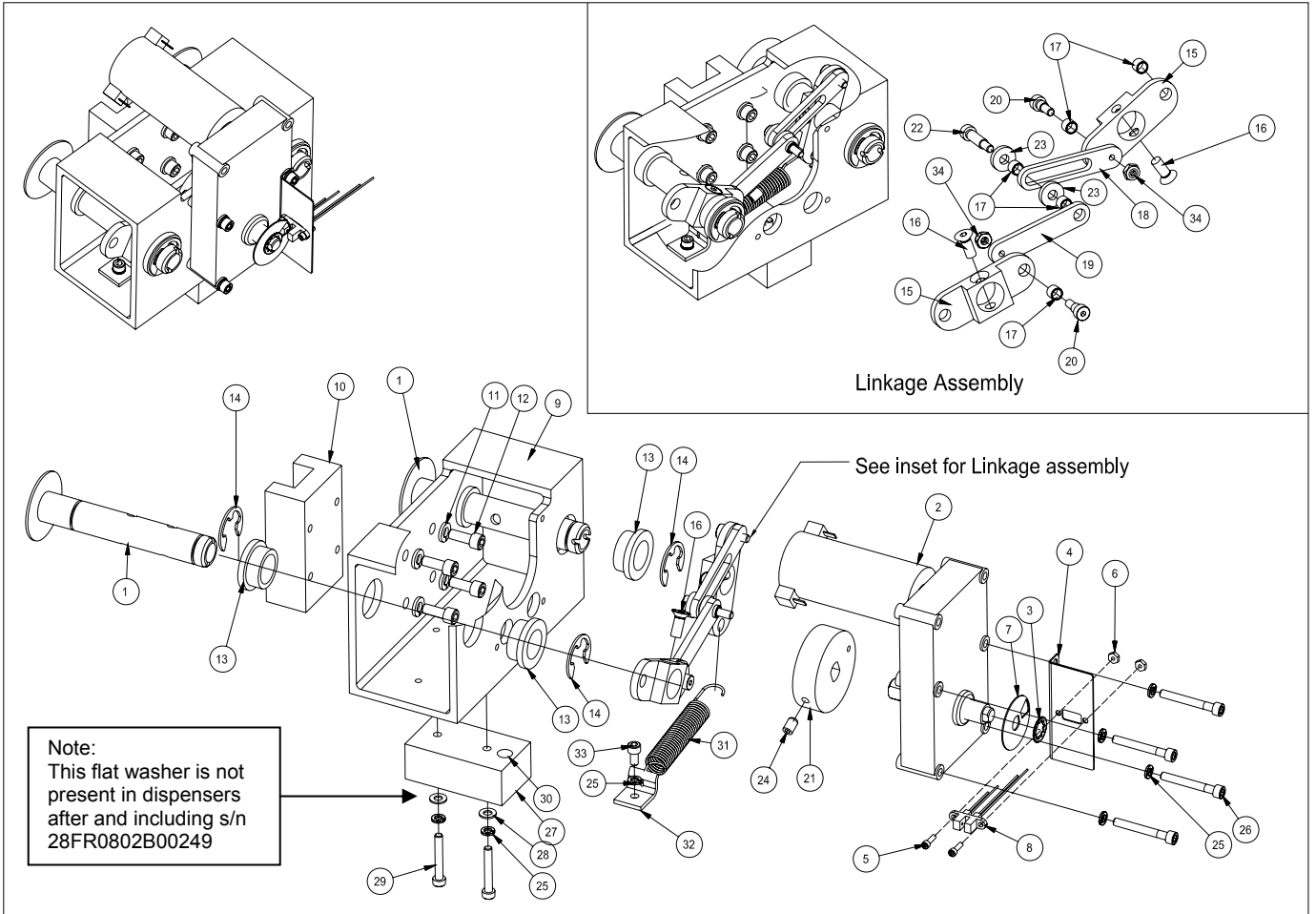

Weighing System Assembly

| Item | Qty | Part#  | Description                              |
|------|-----|--------|--|
| 1    | 2   | 293322 | Weldment, Arm Support                    |
| 2    | 1   | 294009 | Kit, Acc Motor, Includes item 3 & 7      |
| 3    | 1   | 290525 | Retaining Ring, Self Locking, 3/8"       |
| 4    | 1   | 290504 | Bracket Mount, Home Sensor               |
| 5    | 2   | 213663 | Screw 4-40 x 3/8" Socket Head            |
| 6    | 2   | 290529 | Nut, hex #4-40                           |
| 7    | 1   | 293328 | Encoder Disk                             |
| 8    | 1   | 293876 | Accumulator Home Sensor                  |
| 9    | 1   | 293146 | Extrusion, Accumulator Housing           |
| 10   | 1   | 202068 | Assembly, Linear Bearing 180mm           |
| 11   | 4   | 213142 | Washer, Split-lock 1/4"                  |
| 12   | 4   | 203097 | Screw, Socket HD, M6x1x16mm              |
| 13   | 4   | 290517 | Flange Bearing, 3/4" ID x 1" OD, x 1/2"  |
| 14   | 4   | 290531 | Retaining Ring, E-Style, 1/2"            |
| 15   | 2   | 293154 | Accumulator Toggle                       |
| 16   | 2   | 213549 | Screw, socket, flat-head, 1/4"-20x5/8"   |
| 17   | 5   | 203259 | Bearing, Sleeve, 1/4"ID x 5/16"OD x 1/4" |

| Item | Qty | Part#  | Description   |
|------|-----|--------|---|
| 18   | 1   | 293155 | Link, Accumulator   |
| 19   | 1   | 293323 | Link, Accumulator, Push   |
| 20   | 2   | 290635 | Screw, Shoulder, 1/4"x 1/4", #10-24                                   |
| 21   | 1   | 294693 | Kit, Drive Wheel  |
| 22   | 1   |        | Screw, Shoulder, Socket Head, Pelleted (Available only in kit 294693) |
| 23   | 2   | 293325 | Washer, Spacer, 0.25 ID x 0.12"                                       |
| 24   | 1   | 290295 | Set Screw, 1/4-20 x 0.375"  |
| 25   | 5   | 213140 | Washer, lock, #10   |
| 26   | 4   | 213518 | Screw, Socket-head cap, 10-32x1 1/2"                                  |
| 27   | 1   | 293327 | Block, NCWS Magnet Mount  |
| 28   | 2   | 213139 | Washer, Flat, #10 (Rev A only)  |
| 29   | 2   | 213136 | Screw, Socket-head cap, #10-32x1 1/4"                                 |
| 30   | 1   | 290523 | Magnet, NCWS  |
| 31   | 1   | 293384 | Spring, Extension   |
| 32   | 1   | 293390 | Bracket, Spring Base  |
| 33   | 1   | 213262 | Screw, Socket-head cap, M6x1x16mm                                     |
| 34   | 2   | 204761 | Nut, Nylon lock, Hex, 18-8 SS, 5/16-18                                |

**Part Identification Cont.**

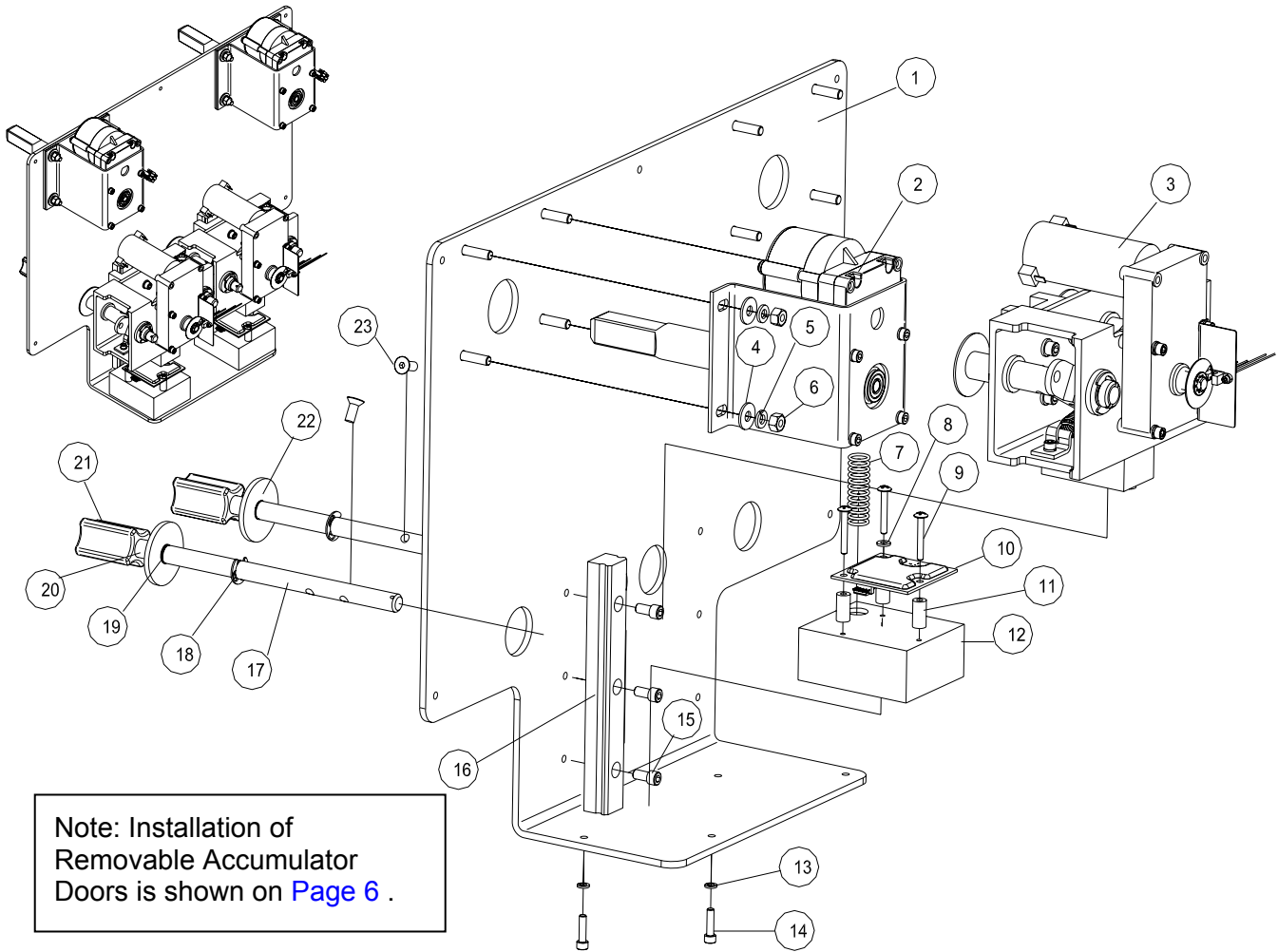

Note: Installation of Removable Accumulator Doors is shown on [Page 6](#) .

**Dispensing System Assembly** ( Models prior to s/n 28FR0802B0249)

| Item | Qty | Part#  | Description                              | Item | Qty | Part#  | Description  |
|------|-----|--------|--|------|-----|--------|--|
| 1    | 1   | 293152 | Mechanical Panel, 280F                   | 12   | 2   | 293326 | Kit, NCWS Base, w/screws                                 |
|      | 5   | 213559 | Screw, Truss HD, 10-32x1/2" SST          | 13   | 4   | 213140 | Washer, Lock ,Reg Spr, ZP #10.ipt                        |
| 2    | 2   | N/A    | Assembly, Drum Motor w/ Mount            | 14   | 4   |        | Screw, SH Cap, two included in 294775                    |
| 3    | 2   | N/A    | Assembly, Weighing System                | 15   | 6   | 213143 | Screw, SH Cap, 1/4-20x1/2" L                             |
| 4    | 8   | 213141 | Flat washer, 1/4"                        | 16   | 2   | 202068 | Assembly, Linear Bearing, 180mm                          |
| 5    | 8   | 213142 | Washer, split lock, 1/4"                 | 17   | 4   | 293908 | Assembly, Drive, Accumulator Door (includes Items 18-22) |
| 6    | 8   | 213260 | Hex nut, 1/4-20                          | 18   | 4   | 213356 | Ring, retaining, E-style, ZP, 1/2"                       |
| 7    | 2   | 290656 | Spring, compression, NCWS                | 19   | 4   | 203257 | O-ring, Buna-N, 11/16"ODx1/2"IDx3/32"                    |
| 8    | 2   | 293566 | Washer, Nylon, 0.173x0.375x0.054"        | 20   | 4   | 293878 | Accumulator Shaft Coupler                                |
|      |     |        |  | 20   | 4   | 293936 | Washer, Flat, 3/8"IDx5/8"ODx1/32"                        |
| 9    | 6   | 291308 | Screw, Trusshead, Phillips, #8-32x1 1/4" | 21   | 4   | 293879 | Coupler Nut, Accumulator Door                            |
| 10   | 2   | 290519 | Circuit Board, NCWS                      | 22   | 4   | 293596 | Collar, Accumulator shaft, UHMW                          |
| 11   | 6   | 292252 | Standoff, Nylon, Unthreaded, 0.75"L      | 23   | 4   | 213549 | FH Cap Screw, Socket, ZP, 1/4-20x5/8"L                   |

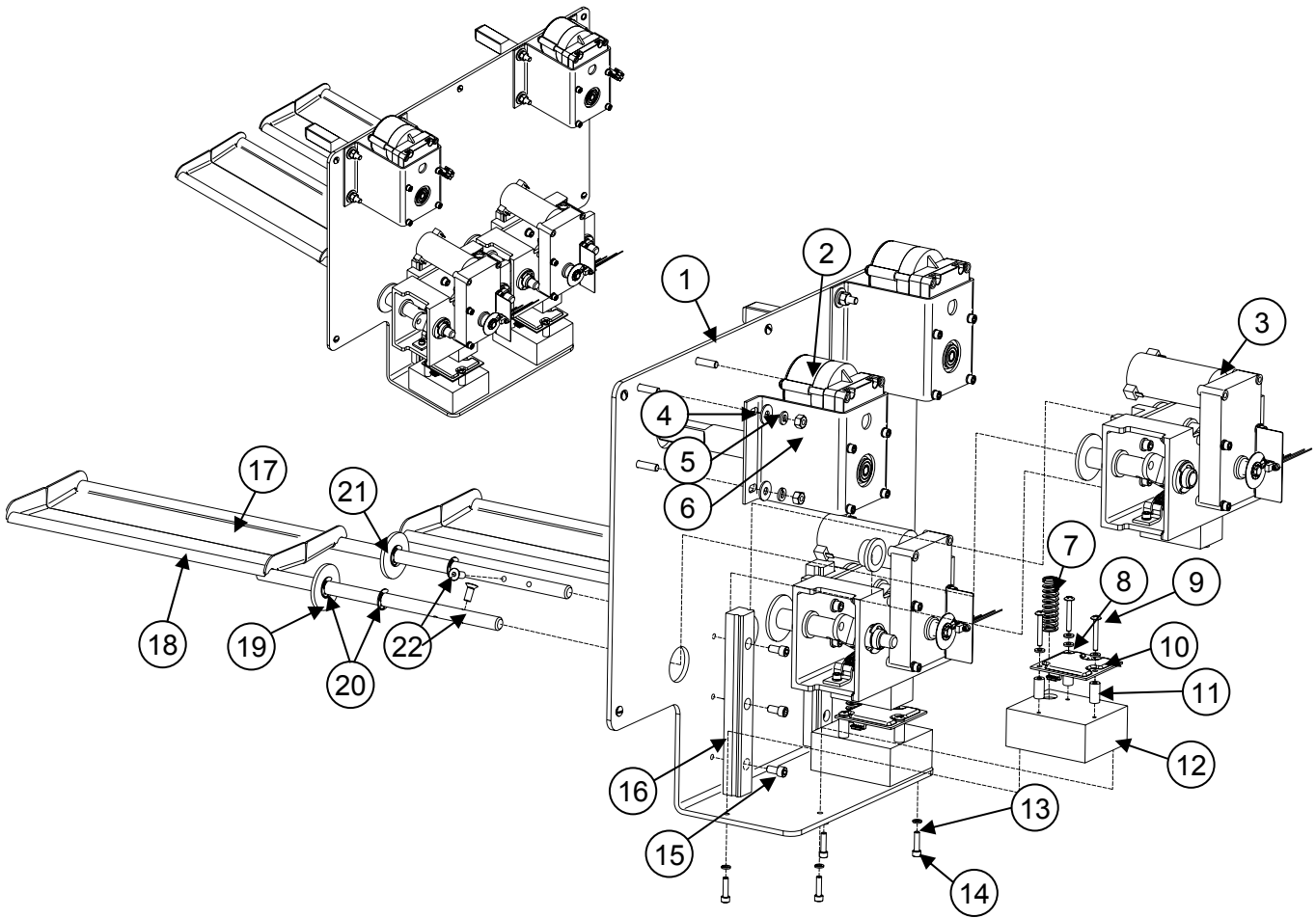

**Dispensing System Assembly (Models after and including s/n 28F0802B0249)**

| Item | Qty | Part#  | Description                              | Item | Qty | Part#  | Description   |
|------|-----|--------|--|------|-----|--------|---|
| 1    | 1   | 293152 | Mechanical Panel, 280F                   | 12   | 2   | 294775 | Kit, NCWS Base w/screws                               |
|      | 5   | 213559 | Screw, Truss HD, 10-32x1/2" SST          | 13   | 4   | 213140 | Washer, Lock ,Reg Spr, ZP #10.ipt                     |
| 2    | 2   | N/A    | Assembly, Drum Motor w/ Mount            | 14   | 4   |        | Screw, SH Cap, two included with 294775               |
| 3    | 2   | N/A    | Assembly, Weighing System                | 15   | 6   | 213143 | Screw, SH Cap, 1/4-20x1/2" L                          |
| 4    | 8   | 213141 | Flat washer, 1/4"                        | 16   | 2   | 202068 | Assembly, Linear Bearing, 180mm                       |
| 5    | 8   | 213142 | Washer, split lock, 1/4"                 | 17   | 4   | 294409 | Assembly, Accumulator Door, LH (includes Items 19-21) |
| 6    | 8   | 213260 | Hex nut, 1/4-20                          | 18   | 2   | 294391 | Assembly, Accumulator Door, RH (includes Items 19-21) |
| 7    | 2   | 290656 | Spring, compression, NCWS                | 19   | 4   | 203257 | O-ring, Buna-N, 11/16"ODx1/2"IDx3/32"                 |
| 8    | 2   | 293566 | Washer, Nylon, 0.173x0.375x0.054"        | 20   | 8   | 213356 | Ring, retaining, E-style, ZP, 1/2"                    |
| 9    | 6   | 291308 | Screw, Trusshead, Phillips, #8-32x1 1/4" | 21   | 4   | 293596 | Collar, Accumulator shaft, UHMW                       |
| 10   | 2   | 290519 | Circuit Board, NCWS                      | 22   | 4   | 213549 | FH Cap Screw, Socket, ZP, 1/4-20x5/8"L                |
| 11   | 6   | 292252 | Standoff, Nylon, Unthreaded, 0.75"L      |      |     |        |   |

**NOTE:** To retrofit these Accumulator Doors to earlier models, remove existing Drive Shaft assemblies (293908, previous page) and replace with items 17 & 18 shown here, the old style NCWS base (item 12) and Accumulator housings (Item 5 on page 32) also need to be upgraded.

**Electrical Cabinet w/Power Supply**

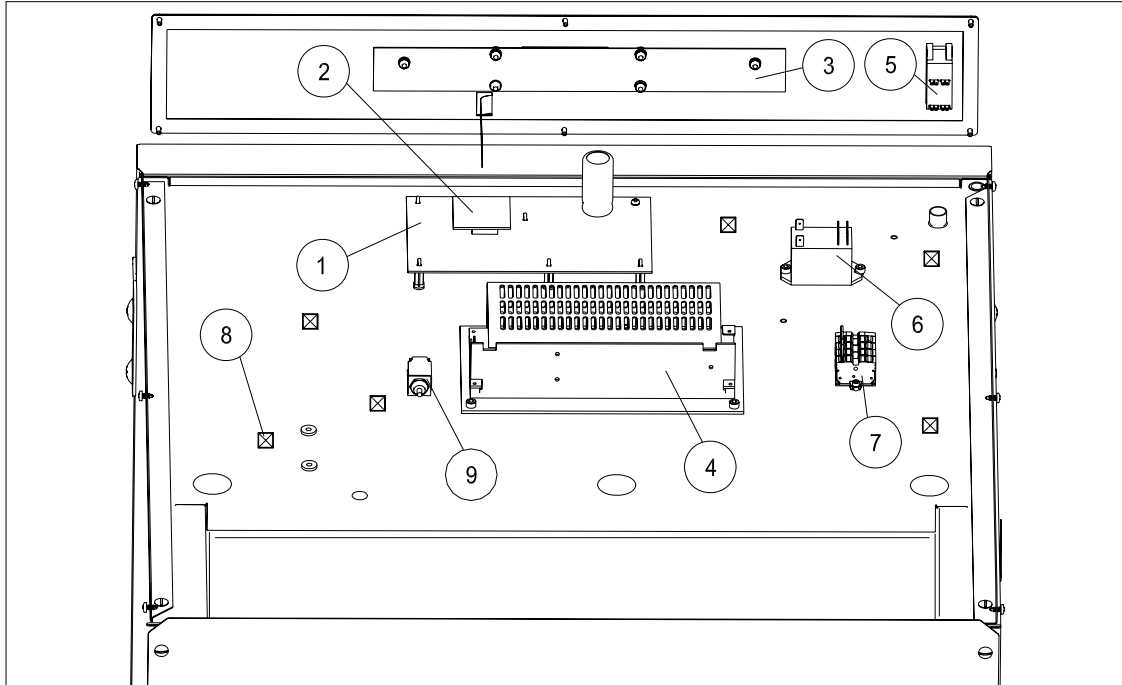

**Electrical Cabinet (Top View)**

| Item | Qty | Part#  | Description  |
|------|-----|--------|--|
| 1    | 1   | 293947 | Controller PCB   |
|      | 5   | 202909 | Stand-Off Nylon  |
|      | 1   | 202977 | Stand-Off  |
|      | 1   | 202795 | Screw, Pan HD w/ washer, ZP, 6-32x3/8"                                 |
| 2    | 1   | 294812 | Processor PCB (Automatic Load Size Reduction)                          |
|      |     | 294837 | Processor PCB EURO (Automatic Load Size Reduction)                     |
|      |     | 294782 | Processor PCB (No Automatic Load Size Reduction)<br><b>See page 15</b> |
| 3    | 1   | 293807 | Display Panel PCB  |
|      | 1   | 293902 | Ribbon Cable   |
|      | 6   | 290876 | Spacer, Round, Nylon, 3/8" x #8 x 1/8"                                 |
|      | 6   | 202874 | Nut, Hex w/ External Lock Washer, ZP, #6-32                            |
|      | 6   | 293566 | Flat Washer, Nylon   |
|      | 4   | 1      | 293510   |
| 1    |     | 293514 | Mounting plate   |
| 3    |     | 293741 | Screw, M4x6mm  |
| 3    |     | 213262 | Screw, Socket HD Cap, ZP, 10-32x3/8"                                   |
| 5    | 1   | 292246 | On/Off Switch  |
| 6    | 1   | 293405 | Relay  |
|      | 2   | 213262 | Screw, Socket HD Cap, ZP, 10-32x3/8"                                   |
| 7    | 1   | 293401 | Terminal Block   |
|      | 2   | 213144 | Screw, Socket HD Cap, ZP, 6-32x1/2"                                    |
| 8    | 8   | 213321 | Cable Tie Adhesive Back, Nylon, 1"                                     |
| 9    | 1   | 293941 | Circuit Breaker, 4 amp   |
|      | 1   | 293944 | Bracket  |
|      | 1   | 293949 | Nut, Breaker support   |
|      | 1   | 293990 | Screw, Pan-head, Phillips, 4-40x1/4"                                   |

**Wiring Harnesses (Not pictured)**

| Part # | Description                                      | Part # | Description                                       |
|--------|--|--------|---|
| 293406 | 120/220 VAC Harness                              | 293407 | Relay Control Harness                             |
| 293408 | DC Power Harness (Power supply to Control Board) | 293409 | AC Power Harness (Power Supply to Terminal Block) |
| 293411 | Motor Control Harness Domestic 120V              | 293333 | Cabinet Door Heater Wire-Domestic 120V            |
| 294011 | Motor Control Harness International 220V         | 294262 | Cabinet Door Heater Wire International 220V       |



**Controller Board**

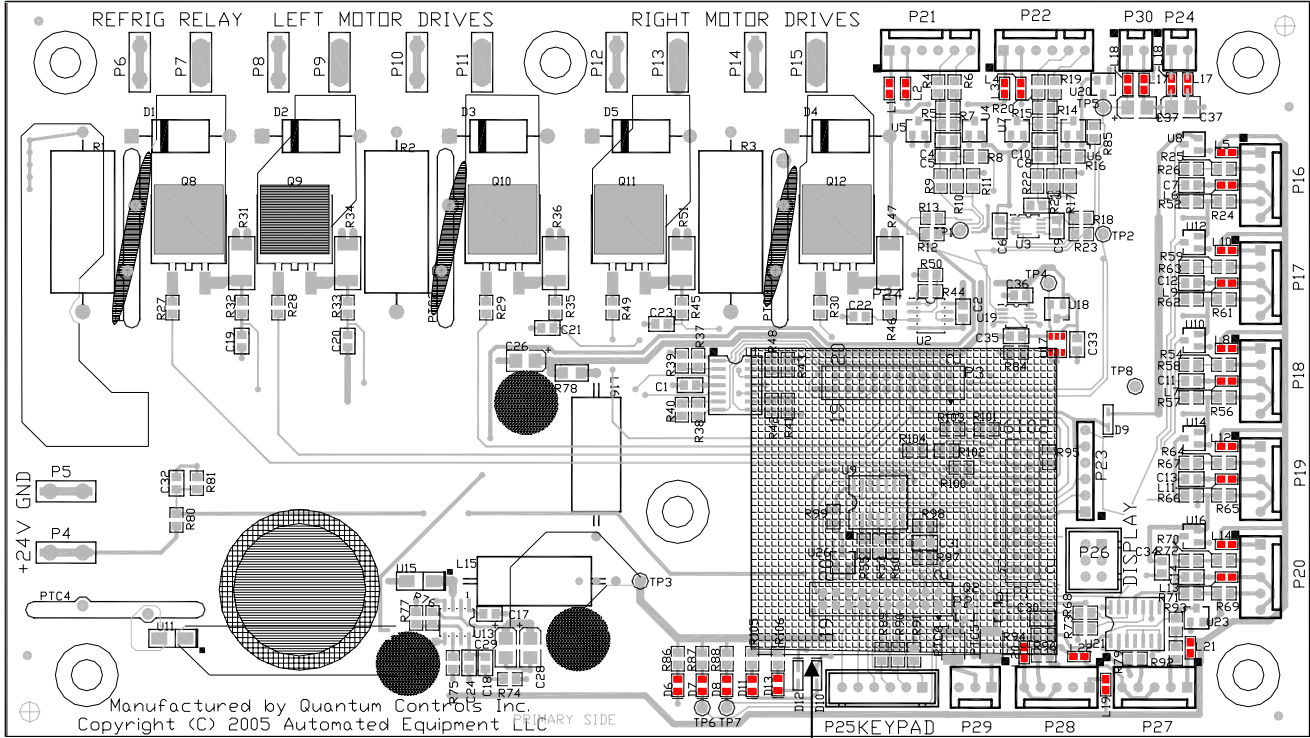

| PART#  | DESCRIPTION                              | QTY |  |
|--------|--|-----|--|
| 293947 | Controller PCB                           | 1   |  |
|        | Processor Board, Removable (see page 38) | 1   |  |
| P4     | Power Input +24VDC (D3)                  | P17 | Right Accum Home Encoder (S2)                    |
| P5     | Power Input $\perp$ (Ground) (D2)        | P18 | Left Basket Sensor (S3)                          |
| P6     | Ref. Relay +24VDC (R1)                   | P19 | Left Accum Home Encoder (S4)                     |
| P7     | Ref. Relay $\perp$ (R2)                  | P20 | High Pressure Switch Relay (P5)                  |
| P8     | Left Drum Motor +24VDC (A1)              | P21 | Right NCWS Board (W1)                            |
| P9     | Left Drum Motor $\perp$ (A2)             | P22 | Left NCWS Board (W2)                             |
| P10    | Left Accum Motor +24VDC (A3)             | P24 | Cabinet Temp. Probe (2 probe configuration only) |
| P11    | Left Accum Motor $\perp$ (A4)            | P25 | Key Pad (operator panel)                         |
| P12    | Right Drum Motor +24VDC (A5)             | P26 | Display Board                                    |
| P13    | Right Drum Motor $\perp$ (A6)            | P27 | Door Switch (Rev C units and later)              |
| P14    | Right Accum Motor +24VDC (A7)            | P28 | Not used   |
| P15    | Right Accum Motor $\perp$ (A8)           | P29 | Not used   |
| P16    | Right Basket Sensor (S1)                 | P30 | Refrigeration Control Probe                      |

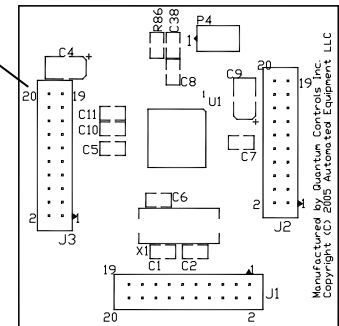

PROCESSOR BOARD

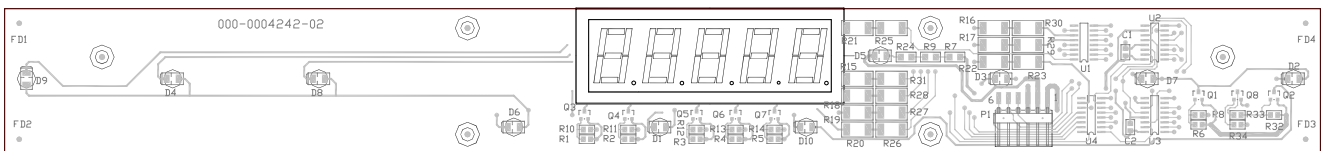

Display Board

| PART # | DESCRIPTION                                | QTY |
|--------|--|-----|
| 293807 | Display Board                              | 1   |
| 293902 | Ribbon Cable, Display Board (not pictured) | 1   |

## Refrigeration System

### General Operation

The RAM 280-F employs a cold wall system. Through the refrigeration process, heat is transferred to the condensing unit at the bottom of the cabinet, where it is expelled to the surrounding outside air. It is extremely important to allow unrestricted airflow for the refrigeration process to function properly.

A minimum of 0.5" (13 mm) clearance on both sides and 2" (50 mm) behind the dispenser is recommended.

The temperature control for the RAM 280-F is capable of detecting conditions that fall outside of normal operation. In such cases, the controller will generate and display an error to warn the operator that an abnormal condition exists and corrective action may need to be taken. Some error conditions are easily fixed, while others may require the attention of a qualified service technician.

See [pages 20-24](#) for a complete list of error codes and a troubleshooting guide.

**CAUTION: Only trained and/or qualified personnel, licensed in refrigeration, should perform service to the refrigeration systems of this equipment.**

The setpoint temperature is the temperature the refrigeration system will attempt to maintain inside the cabinet. The default setpoint temperature is 0°F (-18°C), and has a range of -5°F to 20° F(-20°C to -6°C). The setpoint can be changed using the Manager Menu. (see pg 15). Cabinet temperature is displayed on the operator panel during normal operation.

### Defrost

Because the dispenser employs a cold wall design, it will be necessary to manually defrost the cabinet daily. First, remove the product. Turn the On/Off Switch off. Open the Cabinet Door and allow 1 hour to defrost.

**Caution: Never use a sharp object to remove frost build-up. Never drill or otherwise puncture cabinet walls or top.**

Wipe the cabinet dry when defrosting is complete.

### Required Maintenance

#### **Daily:**

- Shut off, clean, defrost and inspect cabinet. (see [page 9](#))

#### **Monthly:**

- Clean and inspect the condenser filter. Replace as necessary.

**Every 6 months**, or as needed as determined by environmental conditions:

- Inspect the door gasket for proper sealing. Adjust door hinges and/or replace gasket if needed.
- Clean the condenser coils, located behind the condenser filter. (See below.)

### Cleaning the Condenser Filter and Coil

Monthly cleaning of the condensing unit filter will aid the heat transfer characteristics of the refrigeration system, increase its efficiency, and extend the life of the compressor. On dispensers manufactured after serial number LONR0912D01204, remove the louvered front panel by unscrewing the retainer screws and lift out the condenser filter. For earlier dispensers with a louvered drawer, slide the front louvered drawer out and lift out the condenser filter. The filter can be cleaned in warm soapy water (**HCS**). Rinse and shake off the excess water. Replace the filter and close the louvered drawer.

Every 6 months clean the condenser coils. The coils are located behind the condenser filter. The condenser coils should be cleaned with a vacuum or a stiff brush.

**Failure to keep the condenser filter and coil clean and clear of obstructions could result in temperature loss and damage to the compressor and may void the warranty.**

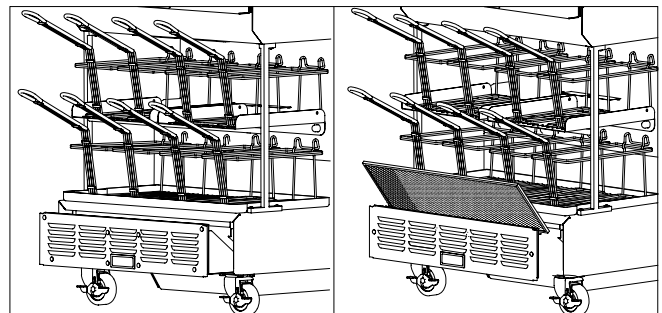

**Refrigeration System Components**

| Item | Qty | Part # | Description   |
|------|-----|--------|---|
| 1    | 1   | 293976 | Condenser   |
| 2    | 1   | 293977 | Fan Shroud  |
|      | 1   | 293979 | Guard, Fan  |
| 3    | 1   | 294339 | Compressor Domestic (120V 1/2HR/ Rev. D)  |
|      |     | 292489 | Compressor Domestic (120V 1/3HR / Rev. A, B, & C)                                 |
|      |     | 294723 | Compressor International (240V 1/2HR / Rev. D)                                    |
|      |     | 294467 | Compressor International (240V 1/3HR / Rev. A, B, & C)                            |
| 4    | 1   | 293980 | Condenser Fan Motor (Dom.120V)  |
|      | 1   | 294419 | Condenser Fan Motor (Int. 220V)   |
|      | 1   | 293981 | Blade, Condenser Fan  |
|      | 1   | 293982 | Bracket, Fan Mounting   |
| 5    | 1   | 292740 | High Pressure Switch  |
| 6    | 1   | 293983 | Overload Switch (1/3hp Dom. 120V)   |
|      |     | 294739 | Overload Switch (1/2hp Dom. 120V)   |
|      |     | 294468 | Overload Switch (1/3hp Int. 240V)   |
|      |     | 294781 | Overload Switch (1/2hp Int. 240V)   |
|      | 1   | 293984 | Start Relay (1/3hp Dom. 120V)   |
|      |     | 294738 | Start Relay (1/2hp Dom. 120V)   |
|      |     | 294418 | Start Relay (1/3hp Int. 240V)   |
|      |     | 294780 | Start Relay (1/2hp Int. 240V)   |
|      | 1   | 293985 | Start Capacitor (1/3hp Dom. 120V)   |
|      |     | 293985 | Start Capacitor (1/2hp Dom. 120V)   |
|      |     | 294417 | Start Capacitor (1/3hp Int. 240V)   |
|      |     | 294779 | Start Capacitor (1/2hp Int. 240V)   |
|      | 1   | 292501 | Filter Drier (not pictured)   |
|      | 1   | 294724 | Capillary Tube 77" (196cm) (1/2 HP Comp.) 0.093" O.D., 0.040" I.D.                |
|      |     | 293986 | Capillary Tube 89" (227cm) (1/3 HP Comp.) 0.093" O.D., 0.040" I.D. (not pictured) |
|      | 1   | 293404 | Terminal Block, Lower (not pictured)  |
|      | 2   | 290529 | Nut ZP 4-40 (not pictured)  |
|      | 1   | 293415 | Heater Wire, Accum. (Dom. 120V)   |
|      |     | 294261 | Heater Wire, Accum. (Int. 220V) (not pictured)                                    |
|      | 1   | 293734 | Feedback Relay (Dom.120V)   |
|      |     | 293974 | Feedback Relay (Int. 240V) (not pictured)   |

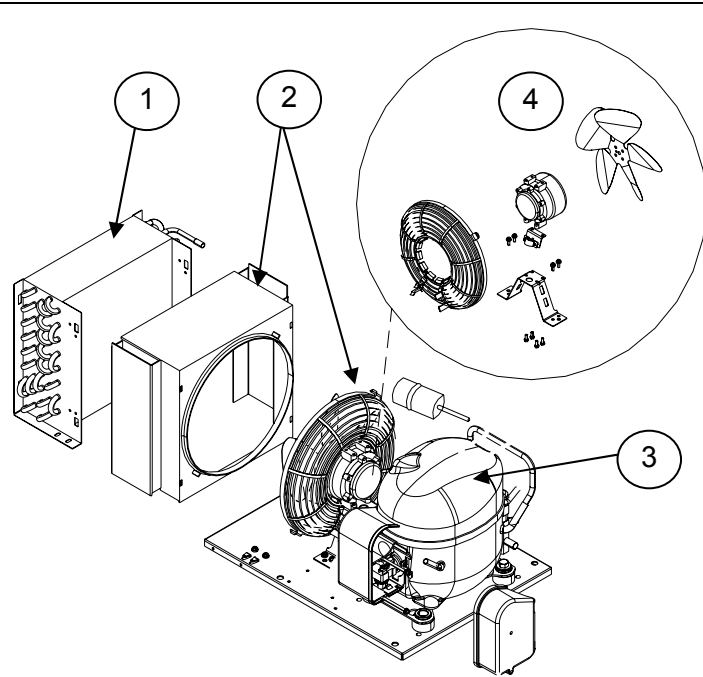

**Condensing Unit Assembly**

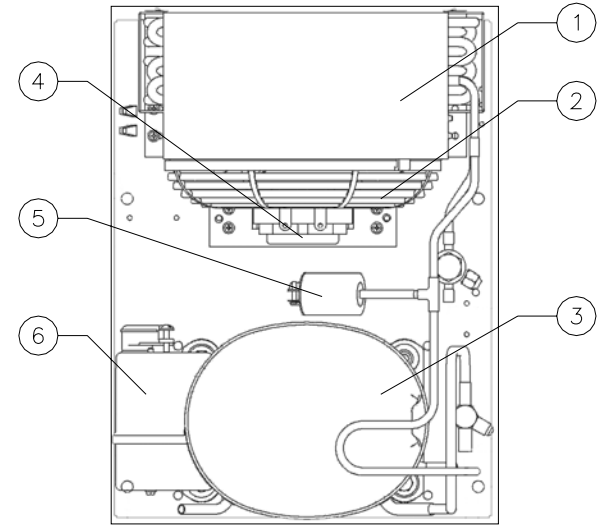

**Refrigeration System Components cont.**

|   |  |
|---|--|
| <p style="text-align: center;"><b>Compressor Identification</b></p> <p>Compressor, Domestic<br/>                 292489 -120V 60HZ 1/3HR / Rev. A, B &amp; C<br/>                 294339 -120V 60 HZ 1/2HR / Rev. D</p> <p>Compressor, International<br/>                 294467 -240V 50HZ 1/3HR / Rev. A, B &amp; C<br/>                 294723 -240V 50HZ 1/2HR / Rev. D</p> | <p><b>Refrigeration Specifications</b></p> <p>Refrigerant: R404A (14.75 oz) (420g)</p> <p>Suction Pressure: 8-10 psi at 0° to 3°F<br/>                 (55kPa to 68kPa at -18° to -16°C)</p> <p>Operating Temperature: -2°F to 10°F<br/>                 (-19°C to -12°C)</p> <p>Factory Temperature Setpoint = 0°F (-18°C)</p> <p>Differential setpoint: 5°F (3°C)</p> <p>Control probe offset: 0°F (0°C)</p> <p>High Pressure switch trips at 425 psi (2890 kPa)<br/>                 resets at 325 psi (2210 kPa)</p> |
|---|--|

**Compressor Start Component Wiring**

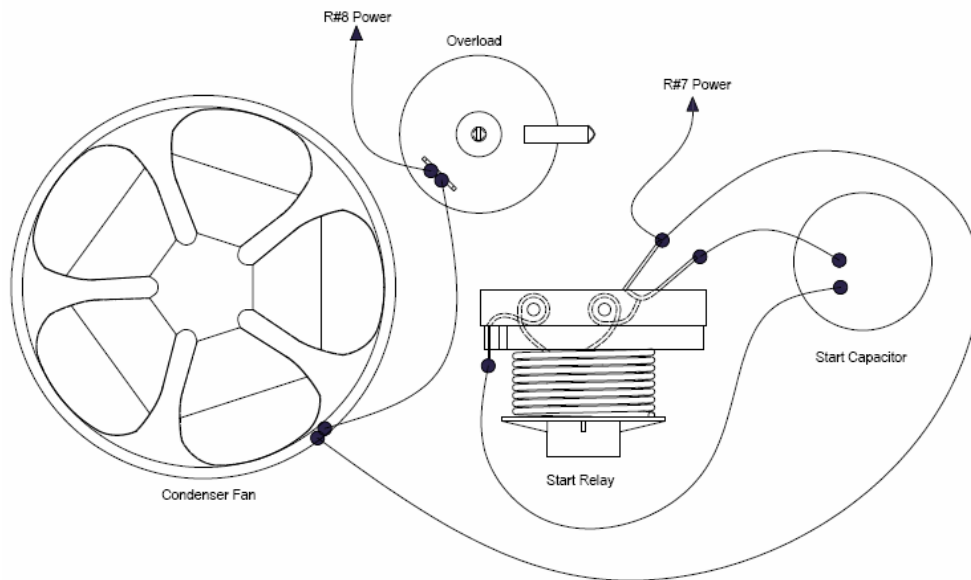

Refrigeration Circuit

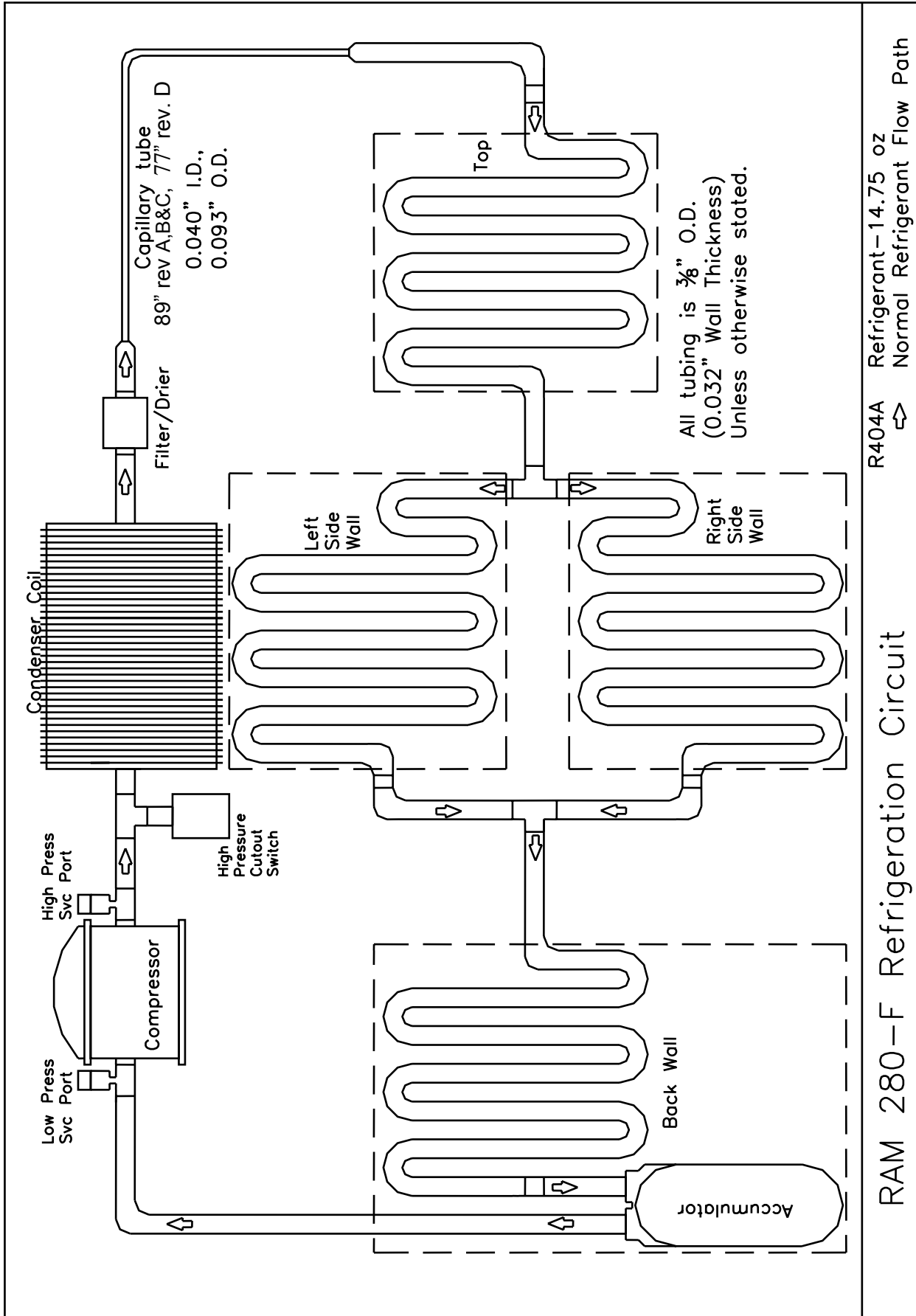

# Electrical Diagram – Two Temperature Probe Configuration

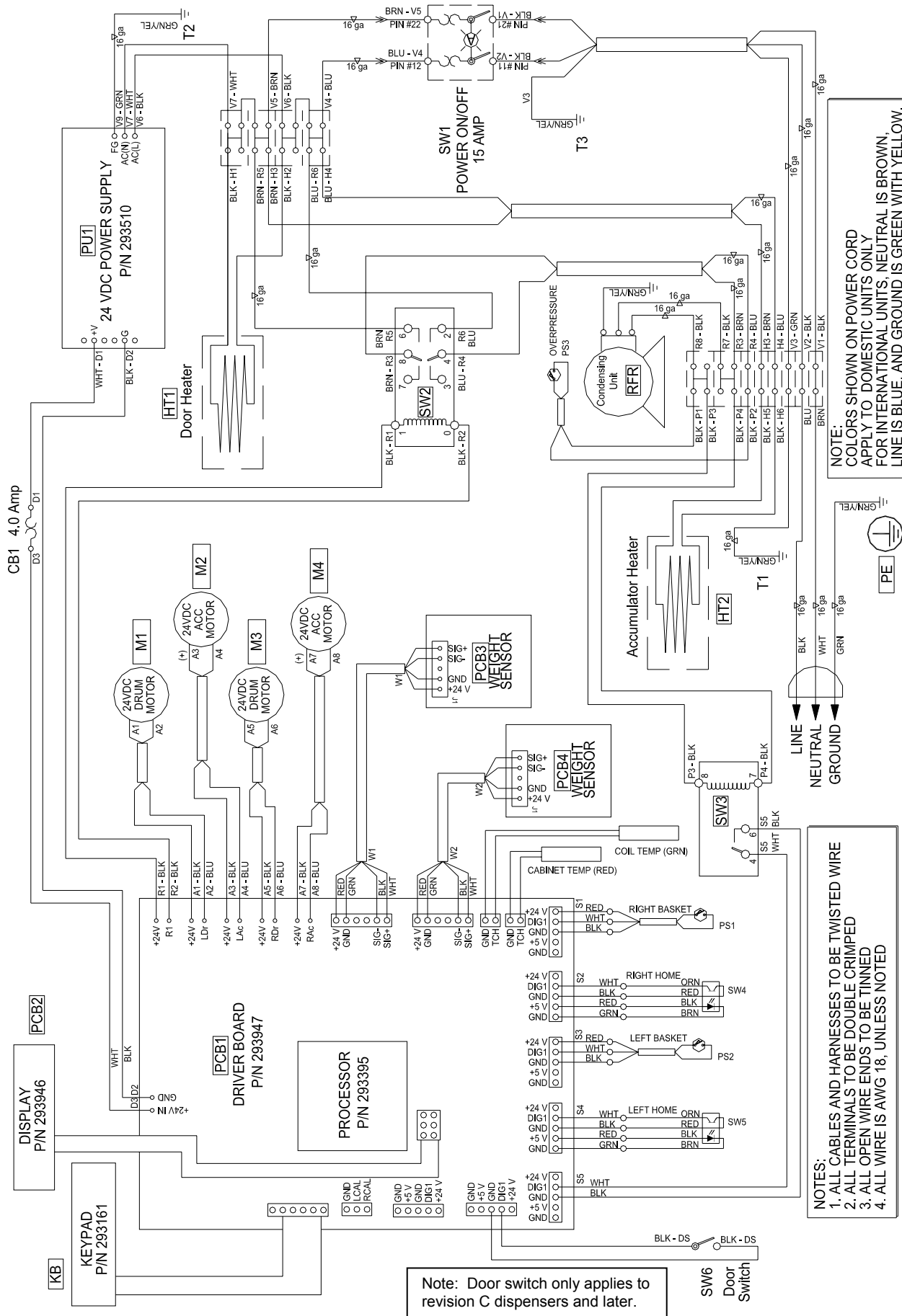

# Electrical Diagram – Single Temperature Probe Configuration

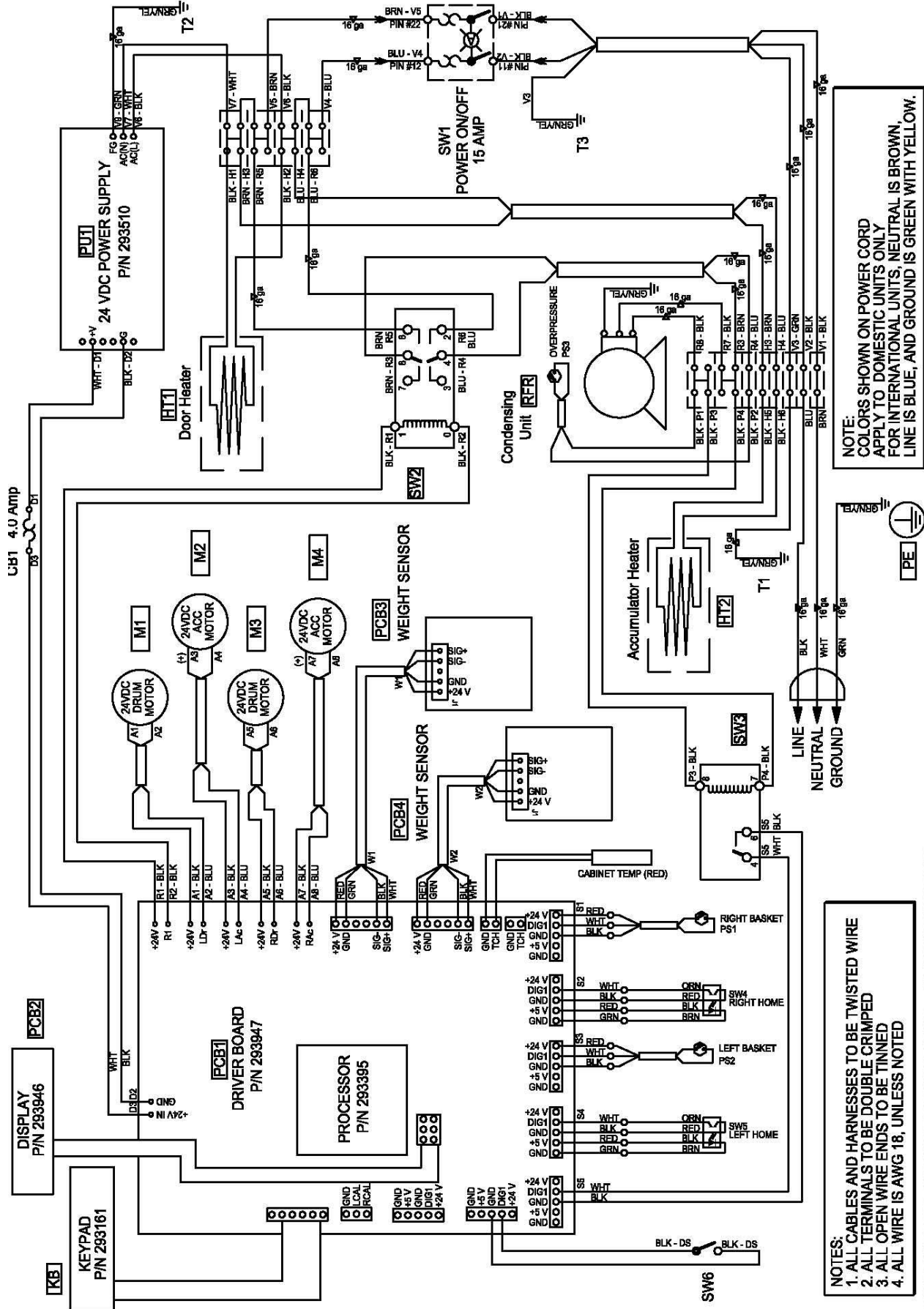

NOTE:  
 COLORS SHOWN ON POWER CORD  
 APPLY TO DOMESTIC UNITS ONLY  
 FOR INTERNATIONAL UNITS, NEUTRAL IS BROWN,  
 LINE IS BLUE, AND GROUND IS GREEN WITH YELLOW.

NOTES:  
 1. ALL CABLES AND HARNESSES TO BE TWISTED WIRE  
 2. ALL TERMINALS TO BE DOUBLE CRIMPED  
 3. ALL OPEN WIRE ENDS TO BE TINNED  
 4. ALL WIRE IS AWG 18, UNLESS NOTED

**Notes:**