

Hot Food Table/Drop-In Gas Common Waterbath models 3400

model 3412 3413 3414 3415

Description:

Gas operated, stainless steel open shelving base hot food table with 20 gauge stainless steel top, and individual die-stamped 12" x 20" top openings. One piece, stainless steel common water bath tank with drain and gate valve below. Gas burner, pilot light and safety shut off system. 7" wide plate shelf with burner control, & 8" wide NSF workboard. Unit on 6" high adjustable legs.

Specifications:

UNIT TOP: Top to be one piece of die formed 20 gauge stainless steel with 1 5/8" square nosing. Top stamped with individual 12"x 20" die formed raised perimeter openings with common water bath tank below. Provided with 7" deep, removable 20 gauge stainless steel plate shelf, and 8" wide x 1/2" thick, full length NSF composition workboard.

FOOD WELLS: 12"x 20" die formed raised perimeter openings in stainless steel unit top. 12,000 B.T.U. gas burner(s) assembly with safety shut-off and pilot light system mounted below one piece stainless steel water tank to heat food wells. Supplied with 1" drain and gate valve.

CONTROLS: Controls for burner(s) mounted on front of 7" deep, removable, stainless steel plate shelf.

UNIT BASE: Bottom shelf to be stainless steel with channel bracing. Body ends to be stainless steel. Legs to be 6" high with adjustable bullet foot. Legs mounted to full length channel frame assembly on bottom of body assembly.

Standard Features:

- Die stamped raised sanitary rim pan openings in stainless steel top with water bath tank below
- Stainless steel body construction - no assembly required
- 12000 BTU gas burner(s) with safety shut off and pilot light system
- Stainless steel ends
- Stainless steel, full length plate shelf - 7" deep
- Full length, 8" wide NSF workboard
- 1" drain & gate valve
- 6" high adjustable legs

model 3413 shown with optional casters



Options & Accessories:

- Counter Protectors
- Serving Shelves/Plexi Shields
- Overshelves
- Casters
- Roll Covers
- Adaptor Plates
- Manual Fill Faucet
- Stainless Steel Back

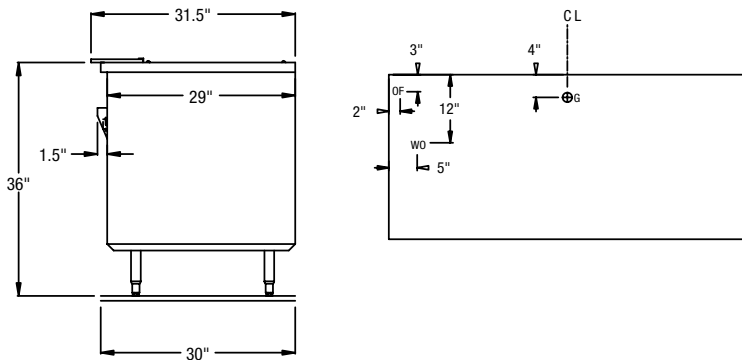
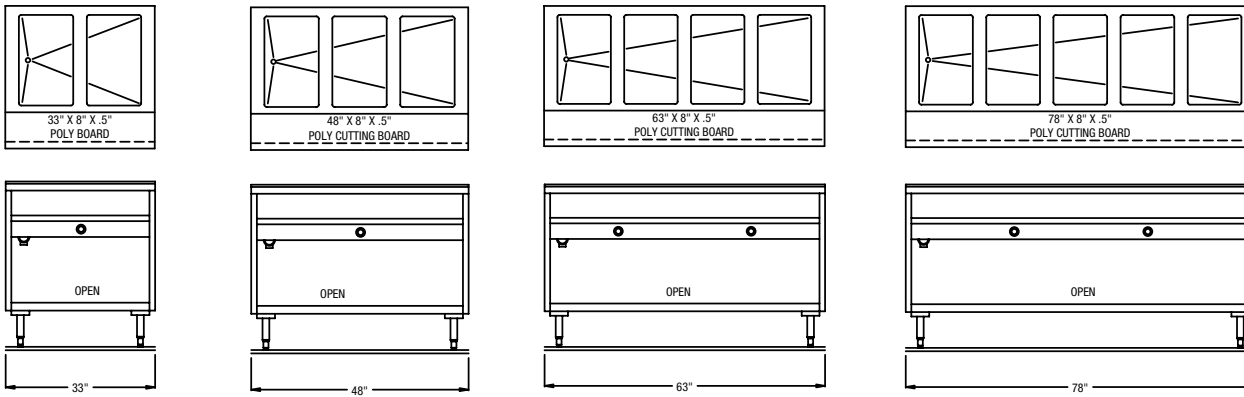

LEGEND FOR MODELS 3400
 AFF = ABOVE FIXED FLOOR
 CHECK ONE:
 NATURAL GAS
 LP GAS
ØG GAS LINE 1/2" BALL VALVE CONNECTION
 19.25" AFF
 24,000 BTUs
WO DRAIN LINE CONNECTION
 1" FPT 23.5" AFF
OF OPTIONAL WATER FILL
 24" AFF

Model	L	D	H	No. of Wells	No. of Burners	Bottom Shelf		B.T.U.	Ship Wt.
						Material	Sq. Ft.		
3412	33"	30"	36"	2	1	S.S.	5.5	12,000	116
3413	48"	30"	36"	3	1	S.S.	8.1	12,000	174
3414	63"	30"	36"	4	2	S.S.	10.7	24,000	232
3415	78"	30"	36"	5	2	S.S.	13.3	24,000	290

