

## OPERATORS MANUAL

This manual provides  
Installation & Operating instructions for

# **3400 SERIES GAS HOT FOOD HOLDING UNIT**



### **NOTIFY CARRIER OF DAMAGE AT ONCE.**

It is the responsibility of the consignee to inspect the container upon receipt of same and to determine the possibility of any damage, including concealed damage. Randell suggests that if you are suspicious of damage to make a notation on the delivery receipt. It will be the responsibility of the consignee to file a claim with the carrier. We recommend that you do so at once.

Manufacture Service/Questions 888-994-7636.

Information contained in this document is known to be current and accurate at the time of printing/creation. Unified Brands recommends referencing our product line websites, [unifiedbrands.net](http://unifiedbrands.net), for the most updated product information and specifications.



**1055 Mendell Davis Drive  
Jackson, MS 39272  
888-994-7636, fax 888-864-7636  
[randell.com](http://randell.com)**

## TABLE OF CONTENTS

Page 2 .....	Congratulations
Page 2 .....	Factory Correspondence
Page 3 .....	Serial Number Location
Page 4 .....	Unit Specifications
Page 6 .....	Randell Limited Warranty
Page 7 .....	Unit Installation
Page 11 .....	Unit Operation
Page 11 .....	Preventative Maintenance
Page 12 .....	Troubleshooting
Page 13 .....	Part Figures

Congratulations on your recent purchase of Randell food service equipment, and welcome to the growing family of satisfied Randell customers.

Our reputation for superior products is the result of consistent quality craftsmanship. From the earliest stages of product design, to successive steps in fabrication and assembly, rigid standards of excellence are maintained by our staff of designers, engineers, and skilled employees.

Only the finest heavy-duty materials and parts are used in the production of Randell brand equipment. This means that each unit, given proper maintenance, will provide years of trouble free service to its owner.

In addition, all Randell food service equipment is backed by one of the best warranties in the food service industry and by our professional staff of service technicians.

Retain this manual for future reference.

**Notice:** Due to a continuous program of product improvement, Randell Manufacturing reserves the right to make changes in design and specifications without prior notice.

**Notice:** Please read the entire manual carefully before installation.

If certain recommended procedures are not followed, warranty claims will be denied.

Model Number \_\_\_\_\_  
Serial Number \_\_\_\_\_  
Installation Date \_\_\_\_\_

**Randell Manufacturing  
Service and Parts  
Hot Line  
1-800-621-8560  
or for our  
Service Agent Listings  
visit our web site at  
[www.randell.com](http://www.randell.com)**

**RANDELL MANUFACTURING  
SERIAL NUMBER LOCATION  
FOR THE  
DROP-IN SERIES**

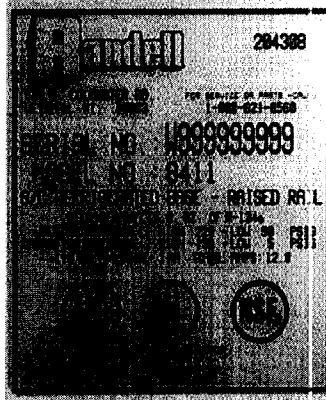

This is a sample of a serial number tag.

The serial number tag on the Drop-In series is located on the control panel.

**UNIT SPECIFICATIONS**

Model	Length	Depth	Number of Wells	Number of Elements	Bottom Shelf		
					Material Sq. Ft.	BTU	Ship Wt.
3412	33"	30"	2	1	S/S 5.5	12,000	116
3413	48"	30"	3	1	S/S 8.1	12,000	174
3414	63"	30"	4	2	S/S 10.7	24,000	232
3415	78"	30"	5	2	S/S 13.3	24,000	290

## IMPORTANT

**WARNING: IMPROPER INSTALLATION, ADJUSTMENT, ALTERATION, SERVICE OR MAINTENANCE CAN CAUSE PROPERTY DAMAGE, INJURY OR DEATH. READ THE INSTRUCTIONS THOROUGHLY BEFORE INSTALLING OR SERVICING THIS EQUIPMENT.**

**The information contained in this manual is important for the proper installation, use, and maintenance of this unit. Adherence to these procedures and instructions will result in satisfactory cooling results and long, trouble free service. Please read this manual carefully and retain it for future reference.**

### **For your Safety**

#### **If you smell gas:**

1. Open windows.
2. **Do not** touch electrical switches, because sparks will ignite the gas.
3. Extinguish any open flames.
4. Immediately call gas supplier.

### **For your Safety**

Do not store or use gasoline or other flammable vapors or liquids in the vicinity of this or any other appliance.

**Warning:** Improper installation, adjustment, alteration, service or maintenance can cause injury or property damage. Refer to this manual for assistance or additional information, consult a qualified installer, service agency, dealer or gas supplier.

### **Important Safety instructions:**

Installation of this hot food table must conform with local codes, or in the absence of local codes, with the national fuel gas code, ANSI Z223.1, latest edition or Canadian codes CGA-B149.1-M91 (natural gas) or CGA-B149.2-M91 (propane). Make sure that the gas supply is the same type as that marked on the appliance data plate.

1. Have your hot food table installed by a qualified installer or service technician.
2. **Location:** Do not locate your hot food table where it may be subject to strong drafts. Make sure the openings of your unit that supply fresh air for combustion and ventilation are not obstructed.

## Warranty Policies

### Parts Warranty

Randell warrants all component parts of manufactured new equipment to be free of defects in material or workmanship, and that the equipment meets or exceeds reasonable industry standards of performance for a period of one year from the date of shipment from any Randell factory, assembly plant or warehouse facility.

**Note: Warranties are effective from date of shipment, with a thirty day window to allow for shipment, installation and set up. In the event equipment was shipped to a site other than the final installation site, Randell will warranty for a period of three months following installation, with proof of starting date, up to a maximum of eighteen months from date of purchase.**

Component parts warranty does not cover glass breakage. Randell covers all shipping cost related to component part warranty sent at regular ground rates (UPS, USPS). **Freight or postage incurred for any express or specialty methods of shipping are the responsibility of the customer.**

### Labor Coverage

In the unlikely event a Randell manufactured unit fails due to defects in materials or workmanship within the first ninety days, Randell agrees to pay reasonable labor incurred. During the first ninety days work authorizations are not required for in warranty repairs. However, repair times are limited to certain flex rate schedules and hours will be deducted from service invoices if they exceed allowed times without prior approval and a work authorization number. Warranties are effective from date of shipment, with a 30 day window to allow for shipment, installation and setup.

Where equipment is shipped to any site other than final installation Randell will honor the labor warranty for a period of ninety days following installation with proof of starting date, up to a maximum of nine months from date of purchase. Travel time is limited to one hour each direction or two hours per invoice.

**Any travel time exceeding two hours will be the responsibility of the customer.**

### Export Warranty

Our export warranties will cover all non electrical parts for the period of one year from the date of shipment to be free of defects in material or workmanship. Electrical parts are also covered if ordered and operated on 60 Hz. Electrical components, ordered and operated on 50 Hz, are warranted for the first 90 days from shipment only. Service labor is covered for the first 90 days with authorization from factory prior to service. Warranty is automatically initiated 60 days from ship date. Inbound costs on any factory supplied items would be the responsibility of the customer. Adherence to recommended equipment maintenance procedures, according to the owners manual provided with each unit, is required for this warranty to remain in effect, and can have a substantial effect on extending the service life of your equipment. Equipment abuse voids any warranty. Extended warranties are not available for parts, or labor on units shipped outside the United States.

### Freight Damage

Any and all freight damage that occurs to a Randell piece of equipment as a result of carrier handling is not considered warranty, and is not covered under warranty guidelines. Any freight damage incurred during shipping needs to have a freight claim filed by the receiver with the shipping carrier (note all damages on freight bill at time of delivery). Internal or concealed damage may fall under Randell's responsibility dependent upon the circumstances surrounding each specific incident and are at the discretion of the Randell in-house service technician.

**NOTICE: FOOD LOSS IS NOT COVERED UNDER WARRANTY**

## **Unit Installation**

### **A. Receiving Shipment**

Upon arrival, examine the exterior of the shipping crate for signs of abuse. It is advisable that the shipping crate be partially removed, in order to examine the cabinet for any possible concealed damages which might have occurred during shipment. If no damages are evident, replace the crate in order to protect the unit during storage and local delivery. If the unit is damaged, it should be noted on the delivery slip or bill of lading and signed to that effect. A claim must be filed immediately against the carrier indicating the extent and estimated cost of damage occurred.

### **B. Normal Installation Steps**

#### **Step 1 - Provide adequate gas supply**

**The hot food table is designed to operate at a pressure of 3.5 inches of water column for natural gas or, if designed for LP gas, 11 inches of water column. Make sure the unit is supplied with the type of gas specified on its data plate. For proper operation the pressure of natural gas supplied to the regulator must be between 4 and 13 inches of water column. For LP gas, the pressure supplied must be between 10 and 13 inches of water column. When checking for proper operation of the regulator, the inlet pressure must be at least 1" greater than the operating (manifold) pressure as given above.**

#### **Step 2 - Connect the hot food table to gas**

**Shut off the main gas supply and leave it off until new hookup has been completed. Use an AGA certified flexible metal gas line, unless local codes require a hard pipe connection, to prevent gas leaks, wrap pipe thread with teflon tape or put pipe joint compound on all male (external) pipe threads.**

1. Install a manual gas line shut off valve in an easily accessible location.
2. Install a male 1/2" flare union adapter to the 1/2" NPT internal thread at inlet of pressure regulator.
3. Install male 1/2" or 3/4" flare union adapter to the NPT internal thread of the manual shutoff valve to keep it from turning.
4. Connect flexible metal base line to the adapter on the hot food table to permit connection at the shut off valve.
5. When all connections have been made, make sure all controls are in the off position and turn on the main gas supply valve. Use a liquid leak detector at all joints and connections to check for leaks in the system.

**CAUTION: DO NOT USE A FLAME TO CHECK FOR GAS LEAKS.**

#### **Step 3 - Operational check of burners**

Operation of all burners should be checked after the hot food table and gas supply lines have been carefully checked for leaks. Turn on burner control, once the air is purged from the supply line light the burner. Try each burner in succession until all burners have been checked.

Quality of flames: The combustion quality of burner flames needs to be determined visually.

- a. Yellow flame - Call for service
- b. Yellow tips on outer cones - Normal for LP gas
- c. Soft blue flames - Normal for natural gas

Note: If the burner flame is yellow call for service. Normal burner flames should have yellow tips or soft blue flames depending on type of gas you use. With LP gas, some yellow tipping on the outer cone is normal.

### **D. Installation Checklist**

After the final location of the unit has been determined refer to the following checklist prior to start up:

1. Check all wiring to ensure that there are no kinked, bare, or loose wires.
2. Check that unit is properly leveled.
3. Refer to the front of this manual for serial number location. Please record this information in your manual on page 3 now. It will be necessary when ordering replacement parts or requesting warranty service.
4. Confirm that unit is holding temperature. Set controls to desired holding temperature.
5. Check unit for any signs of leaking.

## Unit Operation

All units are designed for 145° to 175° operation or 175° to 175° product temperature. When using the unit dry expect at least a 15° drop in product temperatures compared to using it wet. Gas hot food holding units should be operated utilizing water only. However wet operation is usually recommended for higher efficiency. Plumbing: The units drain must have an outlet to an appropriate drainage area or container.

**Note: Drains must be plumbed to all applicable local code requirements.**

**Caution: Moisture collecting from improper drainage can create a slippery surface on the floor and a hazard to employees. When making electrical connections refer to the amperage data listed on the units data plate. Your local code or the national electrical code handbook to be sure the unit is connected to the proper power source.**

## Preventive Maintenance

Randell strongly suggests a preventive maintenance program which would include the following **Monthly** procedures:

1. Clean your hot food unit with a solution of warm water and a mild detergent. The stainless steel portion of your unit can be polished with any quality polish.
2. Drain water from wells daily and wipe them out. Clean wells thoroughly twice a week to help insure a longer life for your wells.

**Note: Do not use chemicals, steel wool or scrapers to clean unit.**

**Caution: Do not use abrasive cleaning solvents.**

Proper maintenance of equipment is the ultimate necessity in preventing costly repairs. By evaluating each unit on a regular schedule you can often catch and repair minor problems before they completely disable the unit and become burdensome on your entire operation. For more information on preventive maintenance consult your local service company or [www.CFESA.com](http://www.CFESA.com). Most repair companies offer this service at very reasonable rates to allow you the time you need to run your business along with the peace of mind that all your equipment will last throughout its expected life. These services often offer guarantees as well as the flexibility in scheduling of maintenance for your convenience. Randell believes strongly in the products it manufactures and backs those products with one of the best warranties in the industry. We believe with the proper maintenance and use you will realize a profitable return on your investment and years of satisfied service.

## Trouble shooting Guide for gas hot food tables

<b>PROBLEM</b>	<b>POSSIBLE CAUSE</b>	<b>REMEDY</b>
Burners do not light or do not burn evenly	1. burner holes may be clogged	1. Clean burner. Make sure not to enlarge holes.
	2. Burners may not be fitted correctly	2. Remove and reinstall properly
Burners have yellow or yellow tipped flames	1. Unknown	1. Call service agency.
Strong odor	4. Improper air/gas mixture	1. Adjust burner air shutter
Unit will not heat	1. Thermostat off	1. Turn on
	2. Pilot not lit	2. Light pilot
	3. Gas valve off	3. Turn on
	4. Unknown	4. Call service agency
Burner flames very large or yellow	1. Out of adjustment	1. If LP check all steps in the install instructions.



PARTS LIST  
FOR  
RANDELL  
3400 SERIES

**GAS HOT FOOD TABLE 3400 SERIES**

ITEM	DESCRIPTION	PART NUMBER	ITEM	DESCRIPTION	PART NUMBER	ITEM	DESCRIPTION	PART NUMBER
1A	TOP, 2 WELL (30"X33")	RP-TOP3312	14D	TANK SUPPORT ASSY - 3415	RP SPT0106	41B	THREADED ORIFICE, NAT GAS	HD GAS0201B
1B	TOP, 3 WELL (30"X48")	RP-TOP3313	15	PLATE, HEAT DIFFUSION	RP PLT0102	42	MIXING CHAMBER	HD GAS1200A
1C	TOP, 4 WELL (30"X63")	RP-TOP3314	16	VALVE, 1" THD GATE	PE VLV1000	43	BURNER, 4" DIA	HD GAS1200B
1D	TOP, 5 WELL (30"X78")	RP-TOP3315	17	VALVE,SAFETY(JOHNSON CTRH17DB-5)	HC GAS175	44	NIPPLE, 12" X 1/2" DIA	RP NIP0102
2A	CUTTING BOARD,7/16"POLY, 8X33	RP-CPH0833	18	THERMOCOUPLER K15DA-24	HC GAS524	45	BRACKET, MANIFOLD	RP BRK0105
2B	CUTTING BOARD,7/16"POLY, 8X48	RP-CPH0848	19	BRACKET, PILOT J641DHA-1	HC GAS641	46	BRACKET, INLET PIPE SUPPORT	RP BRK0106
2C	CUTTING BOARD,7/16"POLY, 8X63	RP-CPH0863	20	VALVE, SHUT OFF 1/2"	PE VLV500			
2D	CUTTING BOARD,7/16"POLY, 8X78	RP-CPH0878	21	VALVE, PILOT	HC GAS651			
3	CLIP, 1/2" CUTTING BOARD	RP-CLP001	22	KNOB, COCK VALVE	HC HAN542			
4A	PANEL, REAR 2 WELL(11.5"X30.5")	RP-PNL0106	23	VALVE, GAS COCK	HC GAS645			
4B	PANEL, REAR 3 WELL(11.5"X45.5")	RP-PNL0107	24A	BURNER, LP PILOT	HC GAS710			
4C	PANEL, REAR 4 WELL(11.5"X60.5")	RP-PNL0108	24B	BURNER, NAT GAS PILOT	HC GAS721			
4D	PANEL, REAR 5 WELL(11.5"X75.5")	RP-PNL0109	25	NIPPLE, 6" X 1/2" DIA	PR NIP560			
5	SIDE, RIGHT	RP-SID0103	26	NIPPLE, 12" X 1/2" DIA	PE NIP645			
6	SIDE, LEFT	RP-SID0104	27	NIPPLE, 4" X 1/2 DIA	PB NIP540			
7	LEG	HD LEG010	28	CAP, BLK 1/2"	PB CAP500			
8	PLATE, LEG	HD PLT010	29	ELBOW, 1/2" STREET	PB ELB501			
9	KNOB, CONTROL	HD KNB003	30	TEE, BLK 1/2"	PB TEE500			
10A	SHELF, BOTTOM 2 WELL(29"X32.5")	RP-SHL0103	31	ELBOW, BLK 1/2" 90	PB ELB500			
10B	SHELF, BOTTOM 3 WELL(29"X47.5")	RP-SHL0104	32	NIPPLE, 8" X 3/4"	RP NIP0101			
10C	SHELF, BOTTOM 4 WELL(29"X62.5")	RP-SHL0105	33	COUPLER, 3/4"	PB CPL080			
10D	SHELF, BOTTOM 5 WELL(29"X77.5")	RP-SHL0106	34	ELBOW, 3/4" STREET	PB ELB751			
11	CHANNEL, LEG	RP CHN0101	35A	TUBE, ALUM 380MM X 1/4" DIA	RP TUB0102			
12	DRAIN STRAINER	RP DSN001	35B	TUBE, ALUM 380MM X 1/4" DIA	RP TUB0101			
13A	TANK 2 WELL (3412) 27"LONG	RP TNK312	36A	REGULATOR, NAT GAS	HD GAS800			
13B	TANK 3 WELL (3413) 42"LONG	RP TNK313	36B	REGULATOR, LP GAS	HD GAS800LP			
13C	TANK 4 WELL (3414) 57"LONG	RP TNK314	37	VENT CAP	HD GAS801			
13D	TANK 5 WELL (3415) 72"LONG	RP TNK315	38	NIPPLE, 1/2" X CL BLK	PB NIP500			
14A	TANK SUPPORT ASSY - 3412	RP SPT0103	39	BUSHING, 1/2 X 1/8" REDUCING	PB BSH512			
14B	TANK SUPPORT ASSY - 3413	RP SPT0104	40	PLUG, 1/8" SQ HD PIPE	PB PLG018			
14C	TANK SUPPORT ASSY - 3414	RP SPT0105	41A	THREADED ORIFICE, LP	HD GAS0102A			

Associated Files:		Miscellaneous Add-ons			Date:	Revision:	Date:
		FILE NUMBER			5/16/01	A	4-23-01 - CC
					T35-3100A		

# 3400 SERIES

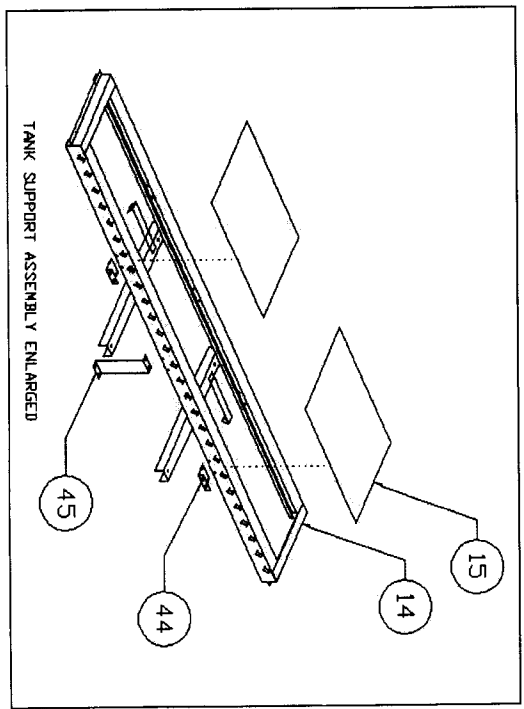
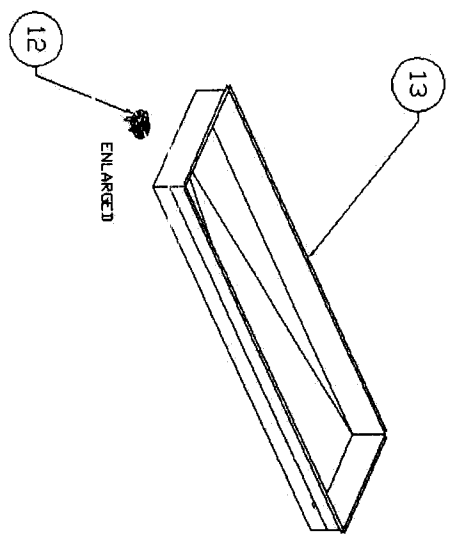
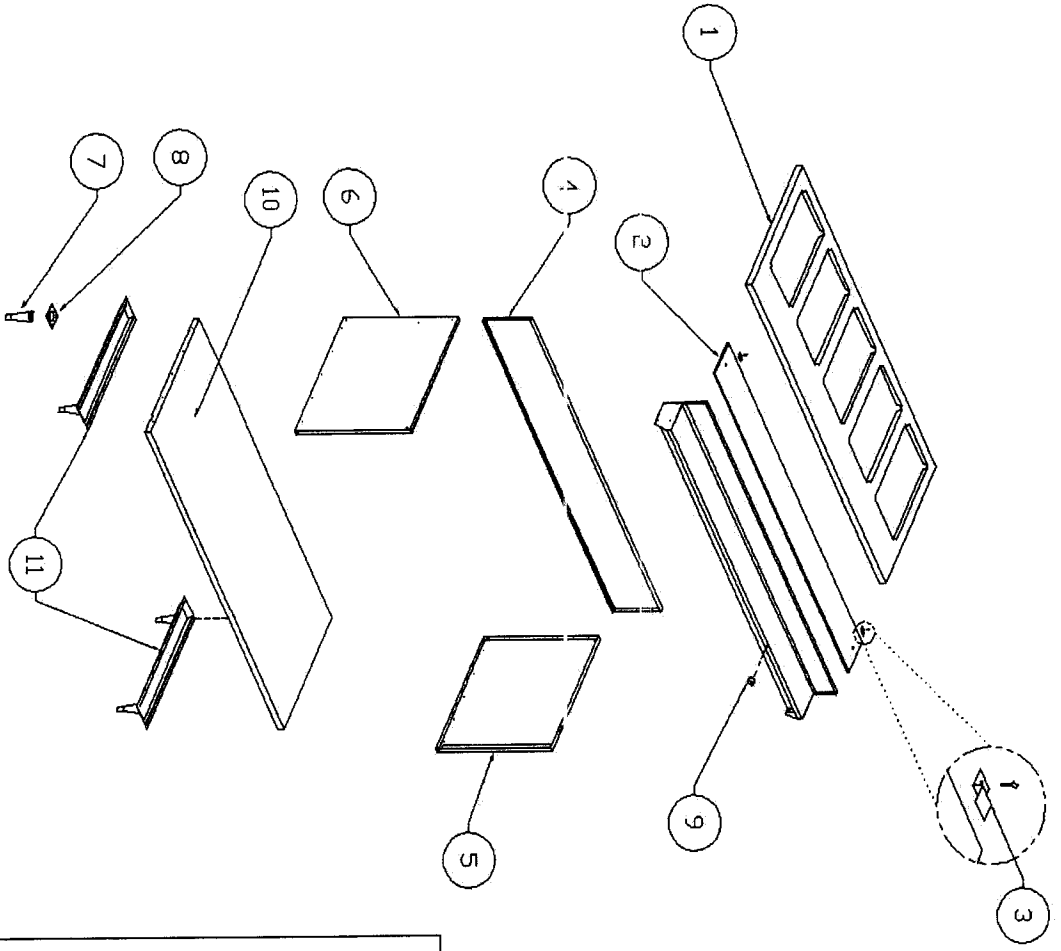

GAS HOT FOOD TABLE

T35-3100B

DATE: 3-20-01  
 Revision A  
 (REV. DATE: 00/00/00)

**3400 SERIES**

CONTROL COPY (1)  
ENG APPROVED

**GAS MANIFOLD  
UNITS 3412 & 3413**

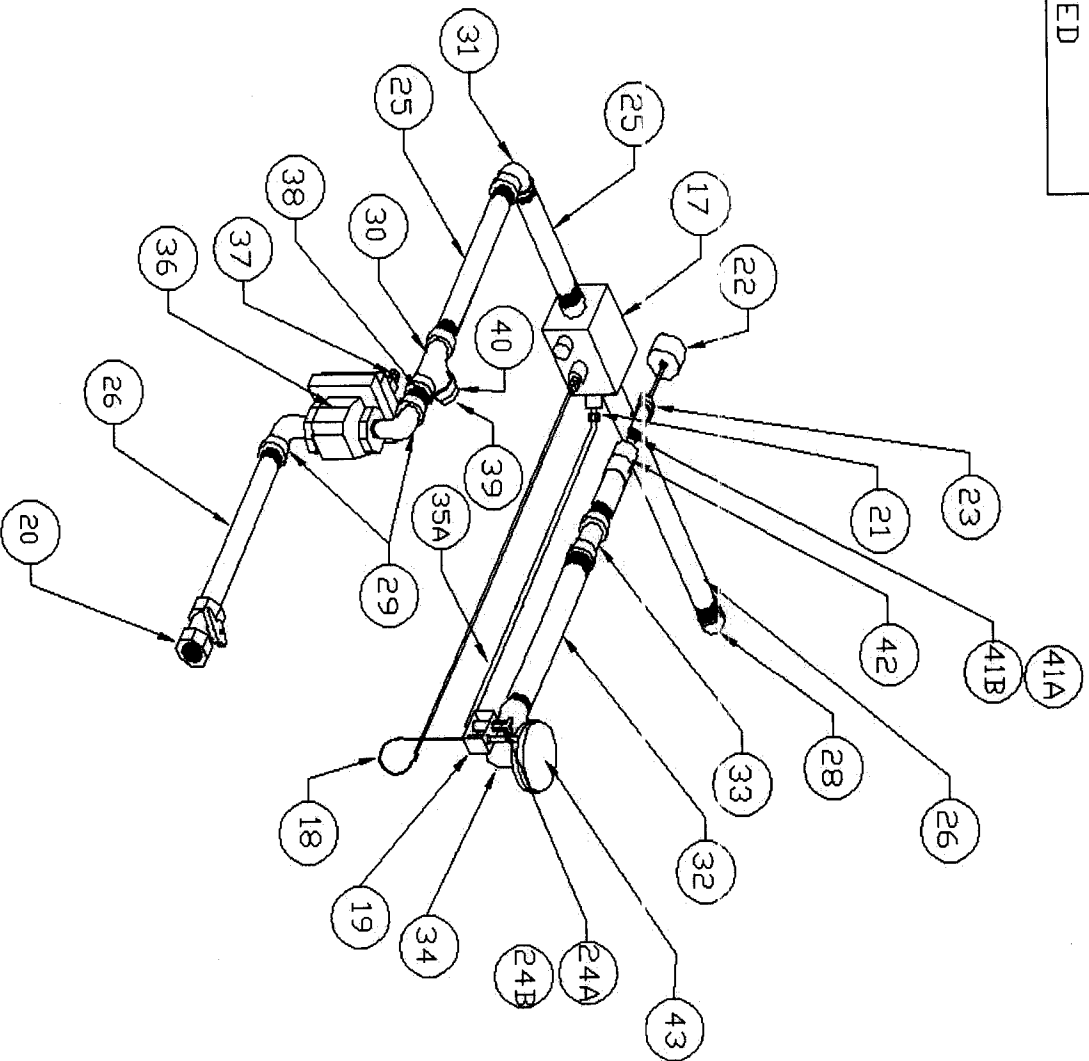
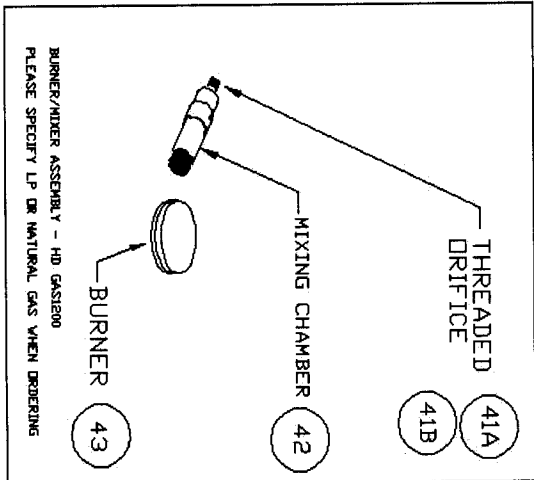

Associated Files:  
FILE NUMBER  
T35-3100A  
T35-3100B  
T35-3100C

**GAS HOT FOOD TABLE  
MANIFOLD ASSEMBLY - 3412 & 3413**



Date:	Revision	Date - XX
05/16/01	A	XX/XX/XX - CC

T35-3100C1

**3400SERIES**

CONTROL COPY (1)  
ENG APPROVED

GAS MANIFOLD  
UNITS 3414 & 3415

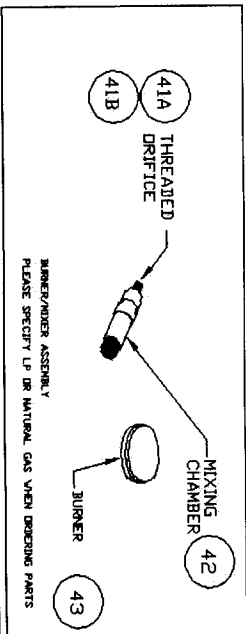
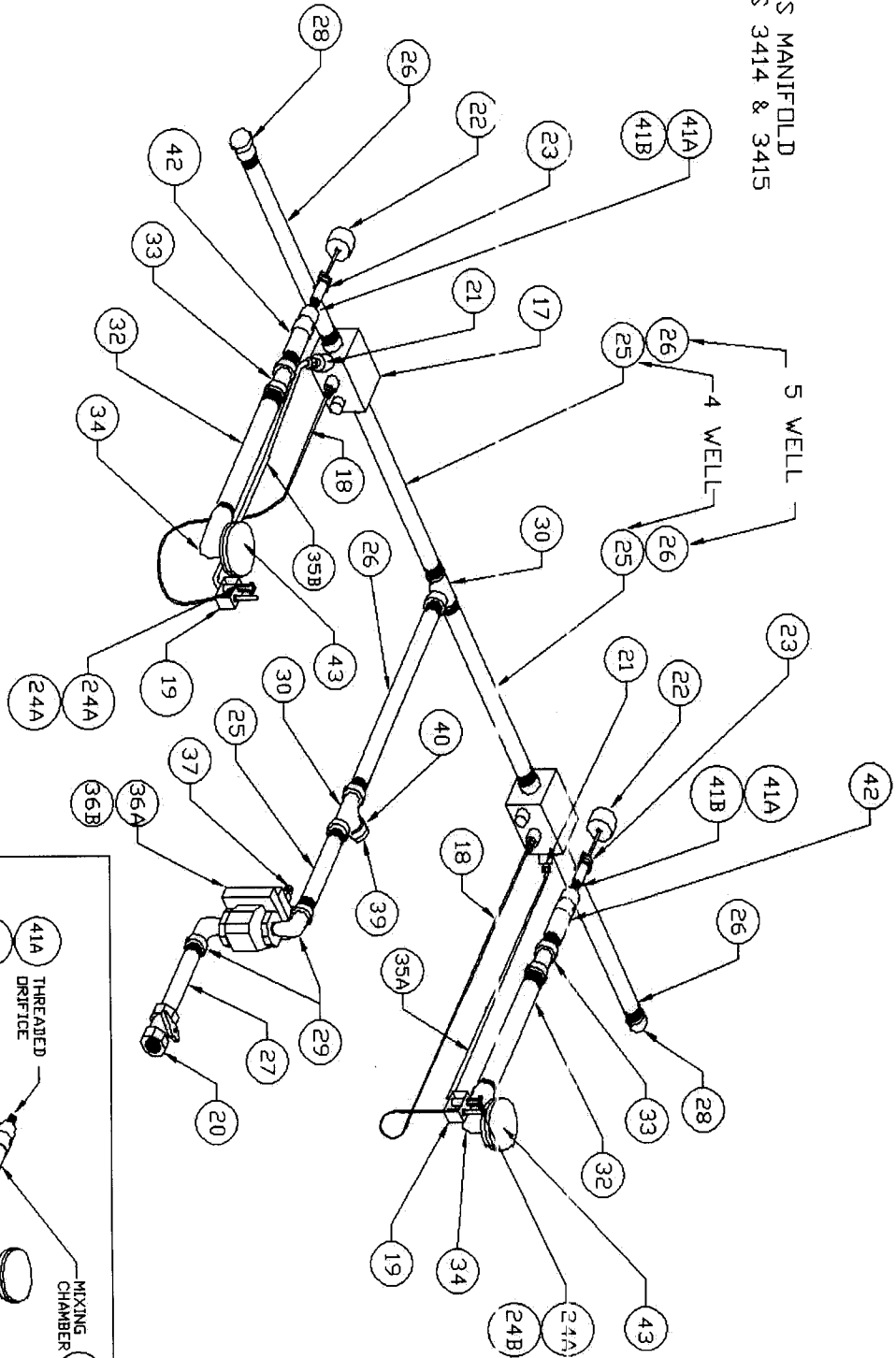

Associated Files:  
FILE NUMBER  
T35-3100A  
T35-3100B  
T35-3100C1

**GAS HOT FOOD TABLE  
MANIFOLD ASSEMBLY - 3414 & 3415**

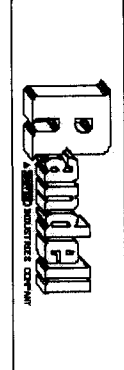

Date: 05/16/01	Revision A	Date - XX:
T35-3100C2		