

TroughVeyor



Job: _____ Item No.: _____

Model TVL



A Water Trough Conveyor and Disposing System

- Model TVL, left hand operation
- Model TVR, right hand operation

Recirculated Water used by the system for scrapping reduces water and sewer costs by thousands of dollars per year compared to a fresh water trough. The TroughVeyor consumes only 7 gallons of fresh water per minute.

Trough Water Velocity with the TroughVeyor is 70 gallons per minute. This velocity swiftly propels food waste down the trough and into the disposer with no additional hand movement, leaving both hands free for high-volume scrapping. The TroughVeyor lets you keep up with large conveyor or flight dishmachines.

Design Flexibility is offered by the TroughVeyor as troughs can turn one or more corners and have wider troughs for soaking problem dishes.

Wider Troughs are made possible by high water velocity that lets you soak problem dishes or add optional gusher heads to pre-rinse compartmented trays

TYPICAL INSTALLATIONS

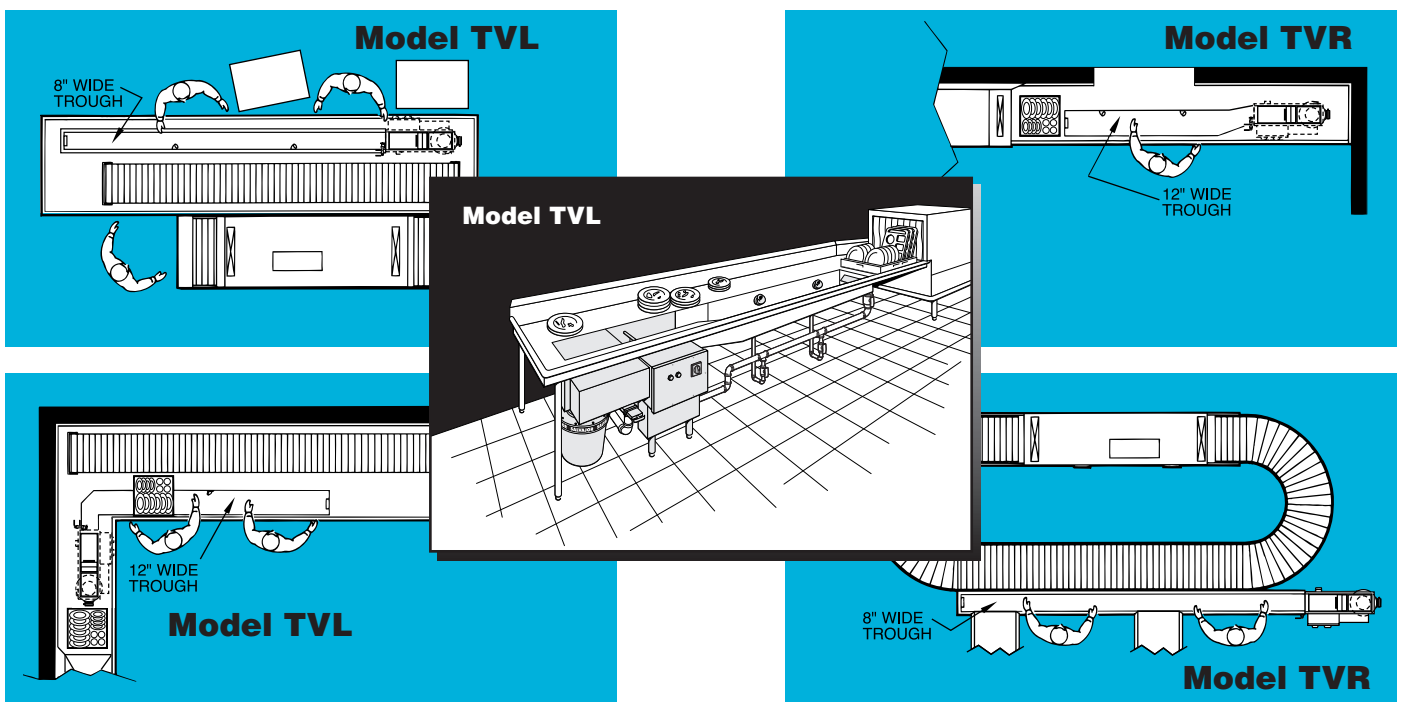

TroughVeyor Model TVL (LEFT HAND OPERATION)

WATER FLOWS RIGHT-TO-LEFT

TroughVeyor Legend

- A** Disposer outlet can be rotated at most any angle by rotating disposer. Rubber drain accepts 2" piping or 3" piping by removing drain insert.
- B** Tank reservoir drain – Plumb 2" piping from valve to floor drain or connect to disposer drain piping ahead of P trap.
- C** Disposer electrical connection.
- D** Disposer to control connection.
- E** Incoming electrical connection.
- F** Hot and cold water connection. 1/2" NPT

ALL CONNECTIONS ARE TO BE MADE BY QUALIFIED PERSONNEL WHO WILL OBSERVE ALL LOCAL AND NATIONAL CODES.

NOTE: Dimensions in parenthesis are in centimeters

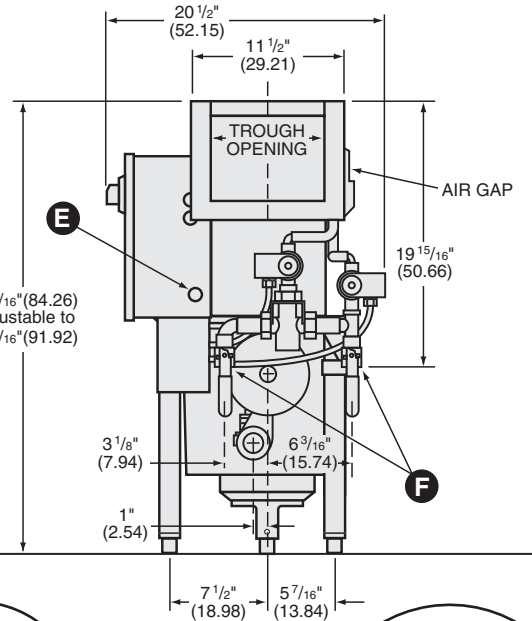
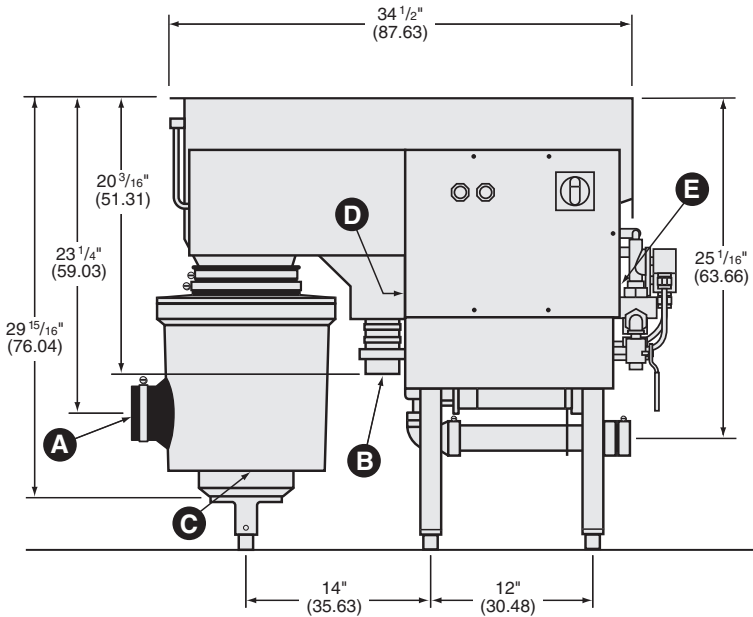
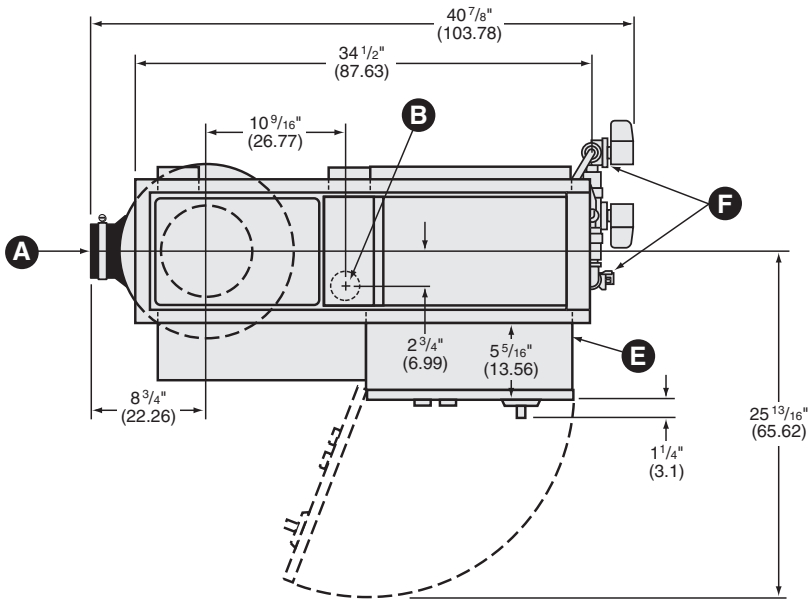
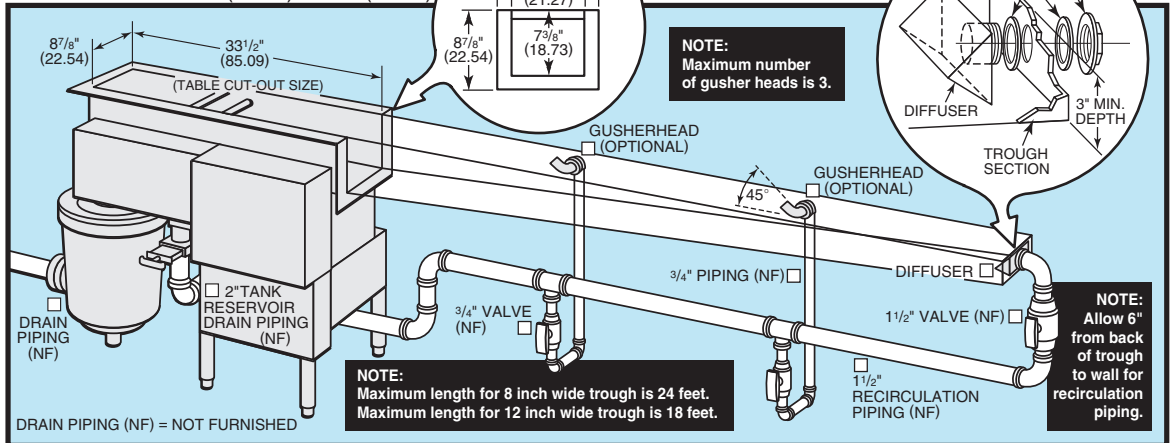
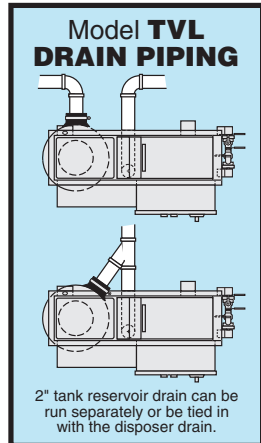

TABLE CUT-OUT: 8 7/8" (22.54) x 33 1/2" (85.09)



TroughVeyor Legend

- A** Disposer outlet can be rotated at most any angle by rotating disposer. Rubber drain accepts 2" piping or 3" piping by removing drain insert.
- B** Tank reservoir drain – Plumb 2" piping from valve to floor drain or connect to disposer drain piping ahead of P trap.
- C** Disposer electrical connection.
- D** Disposer to control connection.
- E** Incoming electrical connection.
- F** Hot and cold water connection. 1/2" NPT

ALL CONNECTIONS ARE TO BE MADE BY QUALIFIED PERSONNEL WHO WILL OBSERVE ALL LOCAL AND NATIONAL CODES.

NOTE: Dimensions in parenthesis are in centimeters

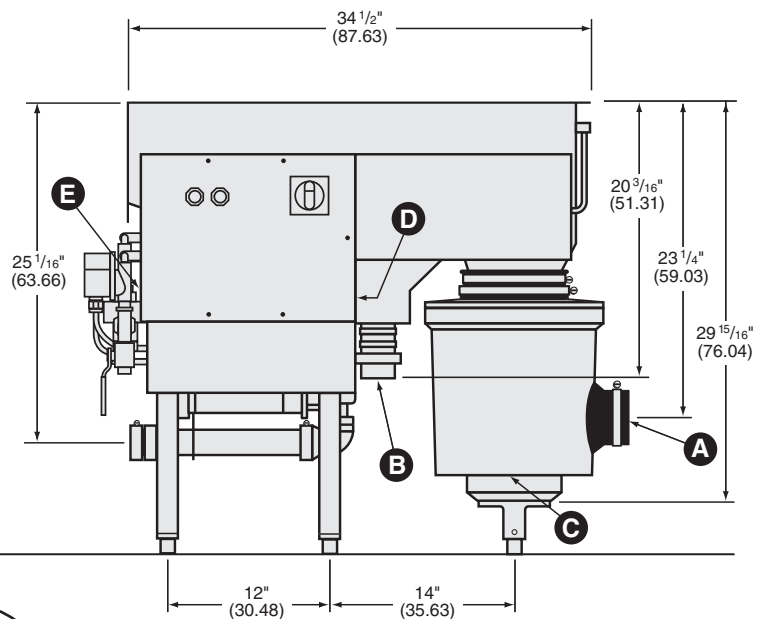
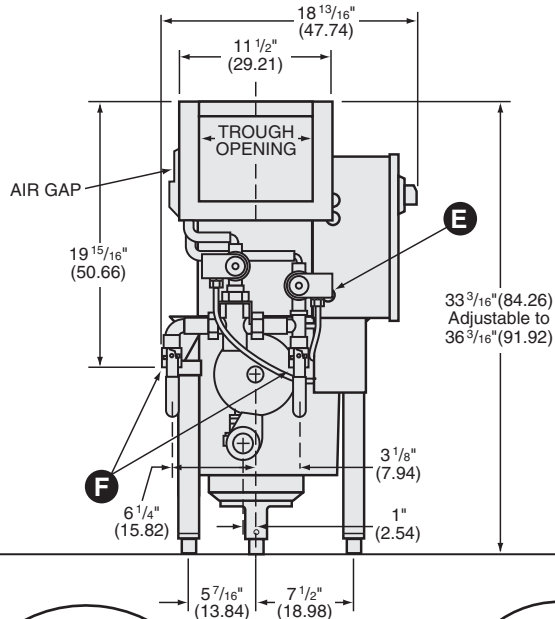
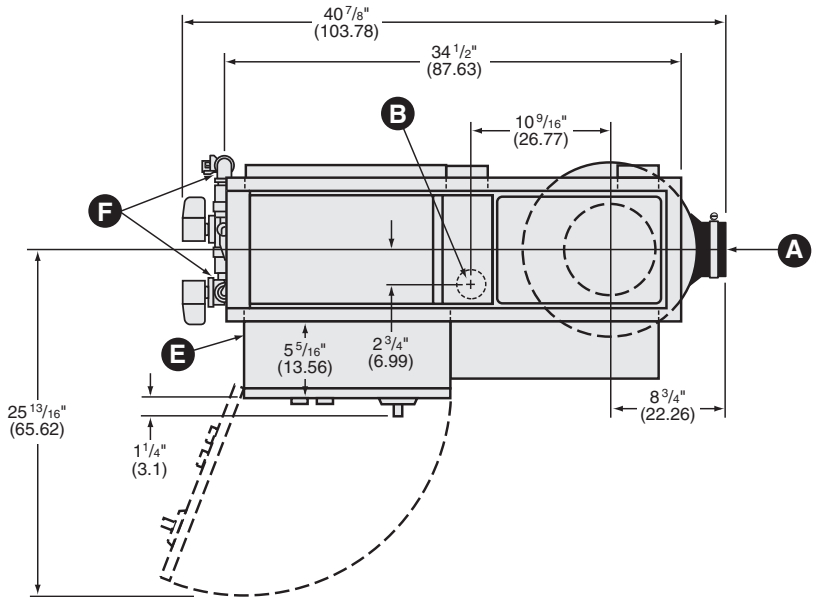

Trough matching flange layout

NOTE: Maximum number of gusher heads is 3.

TABLE CUT-OUT: 8 7/8" (22.54) x 33 1/2" (85.09)

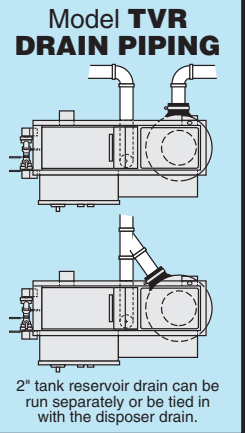
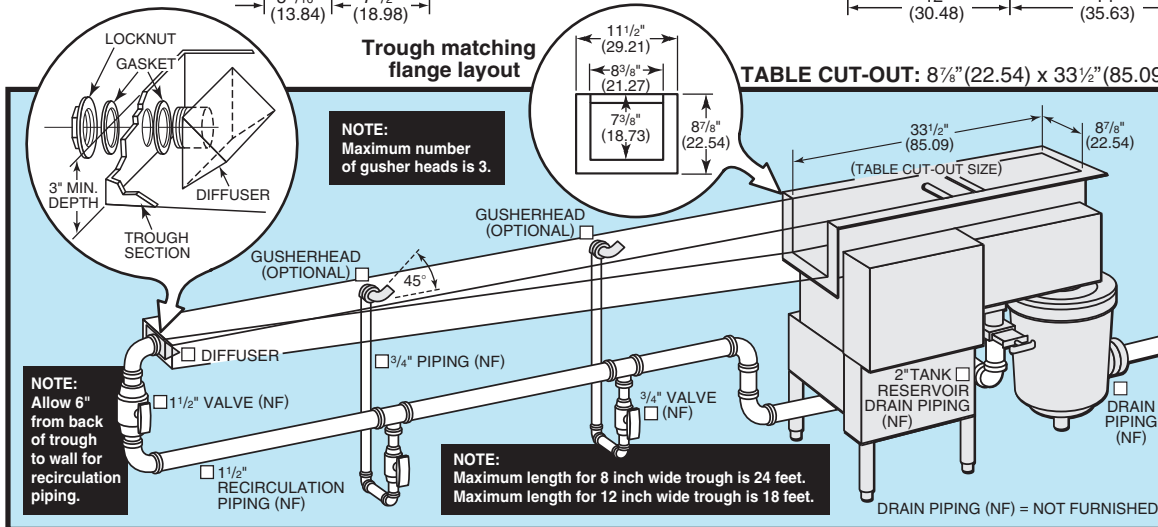

Salvajor TroughVeyor System

MODEL TV

S P E C I F I C A T I O N S

CONSTRUCTION

- Stainless Steel Components
- Salvage Basin
- Disposer Safety Cover
- Adjustable Legs
- Control Panel

ELECTRICAL

- Pre-wired NEMA 4 Panel
- Watertight Conduit/Fittings
- Separate Component Grounding
- Thermally Protected Motors
- Totally Enclosed Motors
- Line Voltage Disconnect
- Disposer Safety Switch
- 24 Volt Safety Circuitry

PLUMBING

- Corrosion Resistant Components
- Automatic Water Blender
- Solenoid Valves
- Unions
- Check Valves
- Incoming Water Valves
- Non-clogging Pump Design
- Backflow Prevention Device
- Quick Opening Drain Valve

SAMPLE SPECIFICATIONS

Unit shall be TroughVeyor, a complete food waste conveying and disposing system with recirculating water as manufactured by Salvajor.
Model ____ TV__, ____ Volts, ____ Hz, ____ Phase.
Furnished with a pre-wired control panel and Stainless Steel NEMA 4 watertight enclosure.

MODELS AVAILABLE

Left-Hand	Right-Hand	Disposer	Lbs.
<input type="checkbox"/> 300 TVL	<input type="checkbox"/> 300 TVR	3 HP	327
<input type="checkbox"/> 500 TVL	<input type="checkbox"/> 500 TVR	5 HP	335
<input type="checkbox"/> 750 TVL	<input type="checkbox"/> 750 TVR	7½ HP	343

ACCESSORIES

- Remote Start-Stop Button
- Remote Mounting Bracket
- Correctional Package
- Gusher Heads

VOLTAGES AVAILABLE

(SPECIFY EXACT OPERATING VOLTAGE)

<input type="checkbox"/> 208V	<input type="checkbox"/> 230V	<input type="checkbox"/> 460V, 60 Cycle, 3 Phase
Disposer	3-7½ HP	208-230-460V
Pump	¾ HP	208-230-460V
Separator	⅙ HP	208-230-460V

FULL LOAD AMPS

MODEL	TOTAL FULL LOAD AMPS			THREE PHASE
	208V	230V	460/480V	Total HP
300-TV	12.64	11.66	5.83	3.92
500-TV	17.64	16.16	8.13	5.92
750-TV	23.64	21.66	10.83	8.42

UTILITIES REQUIRED

208, 230 or 460 Volt, 60 cycle, 3 phase electric service, ¾" hot and cold water supply and reduce to ½" at connection. 2" or 3" waste line, 2" tank reservoir drain.

(Specifications subject to change without notice.)



Disposer not included in listing.

The Salvajor Company 4530 East 75th Terrace Kansas City, Missouri 64132-2081, USA

1-800-SALVAJOR

(816) 363-1030

FAX: 1-800-832-9373

www.salvajor.com

Email: sales@salvajor.com

service@salvajor.com

Manufacturers of Commercial Food Waste Disposing Systems since 1944