

FME1500R SERVICE PARTS

This parts list contains the part numbers and descriptions of the service parts for the FME1500R remote ice machine.

Note: The liquid line filter drier listed in this parts list is designed for this refrigeration system. Premature failure may result if the wrong drier is used.

Table of Contents

PANELS	2
REFRIGERATION	3
EVAPORATOR	4
CONTROL BOX	5
GEARMOTOR	6
RESERVOIR, DRAINS, ICE CHUTE, ICE LEVEL SENSORS	7
REMOTE CONDENSER	8
WIRING DIAGRAMS	9

FME1500R SERVICE PARTS PANELS

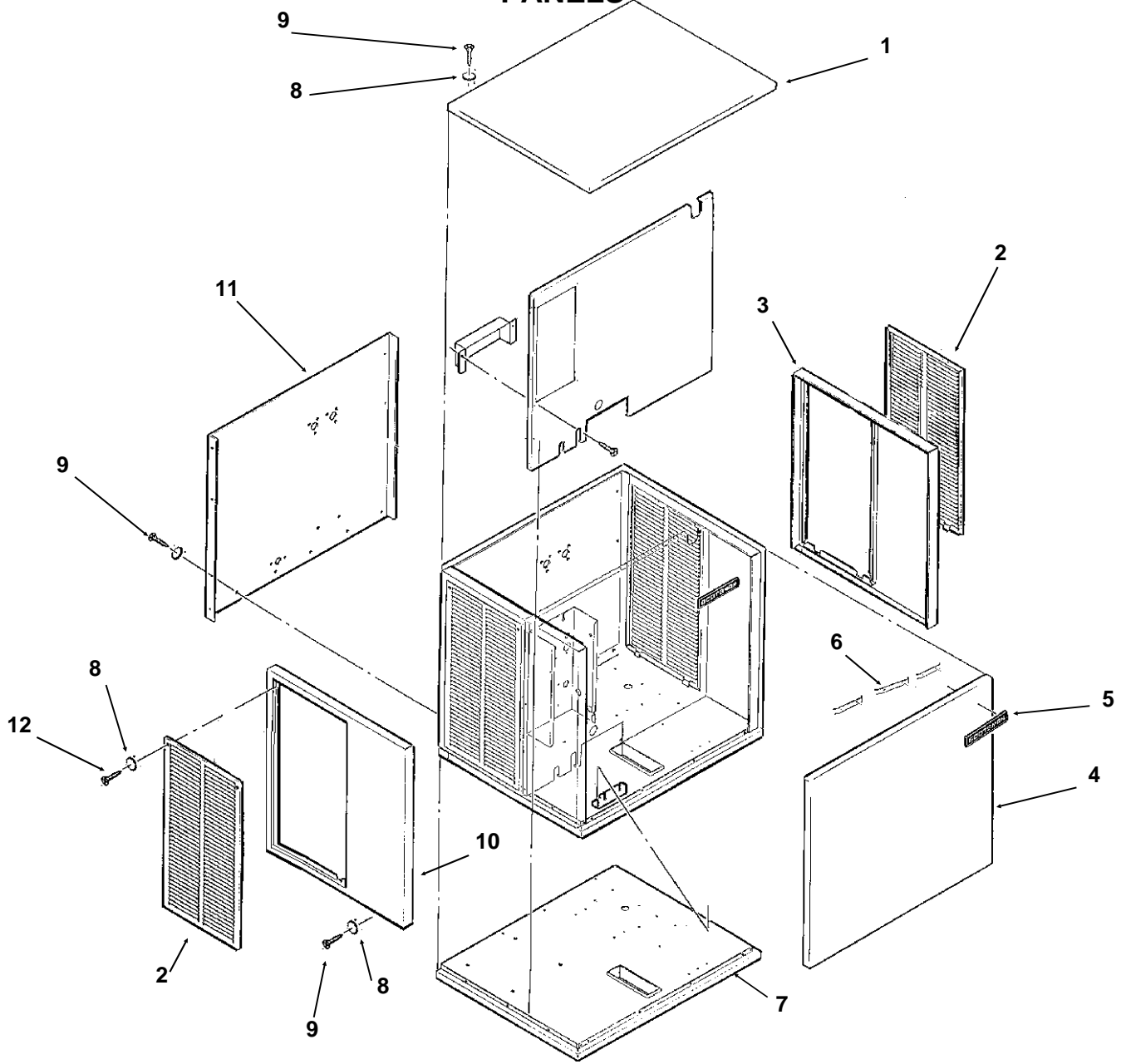

ITEM NUMBER	PART NUMBER	DESCRIPTION	ITEM NUMBER	PART NUMBER	DESCRIPTION
1.	A32159-001	Top Panel Painted	7.	A35955-001	Base Assembly
	A32159-002	Top Panel Stainless	8.	03-1417-27	Washer
2.	A32161-001	Service Panel Paint	9.	03-1531-01	Screw
	A33946-002	Service Panel for S.S.	10.	A32163-001	Left End Panel Pt.
3.	A32162-001	Right End Panel Pt.		A32163-002	Left End Panel S.S.
	A32162-002	Right End Panel S.S.	11.	A32201-001	Back Panel
4.	A32160-001	Front Panel Painted	12.	03-1404-12	Screw
	A32160-002	Front Panel S.S.			
5.	15-0711-01	Emblem for painted			
	15-0711-02	Emblem for stainless			
6.	03-0271-00	Clip For Emblem (3)			

FME1500R SERVICE PARTS REFRIGERATION

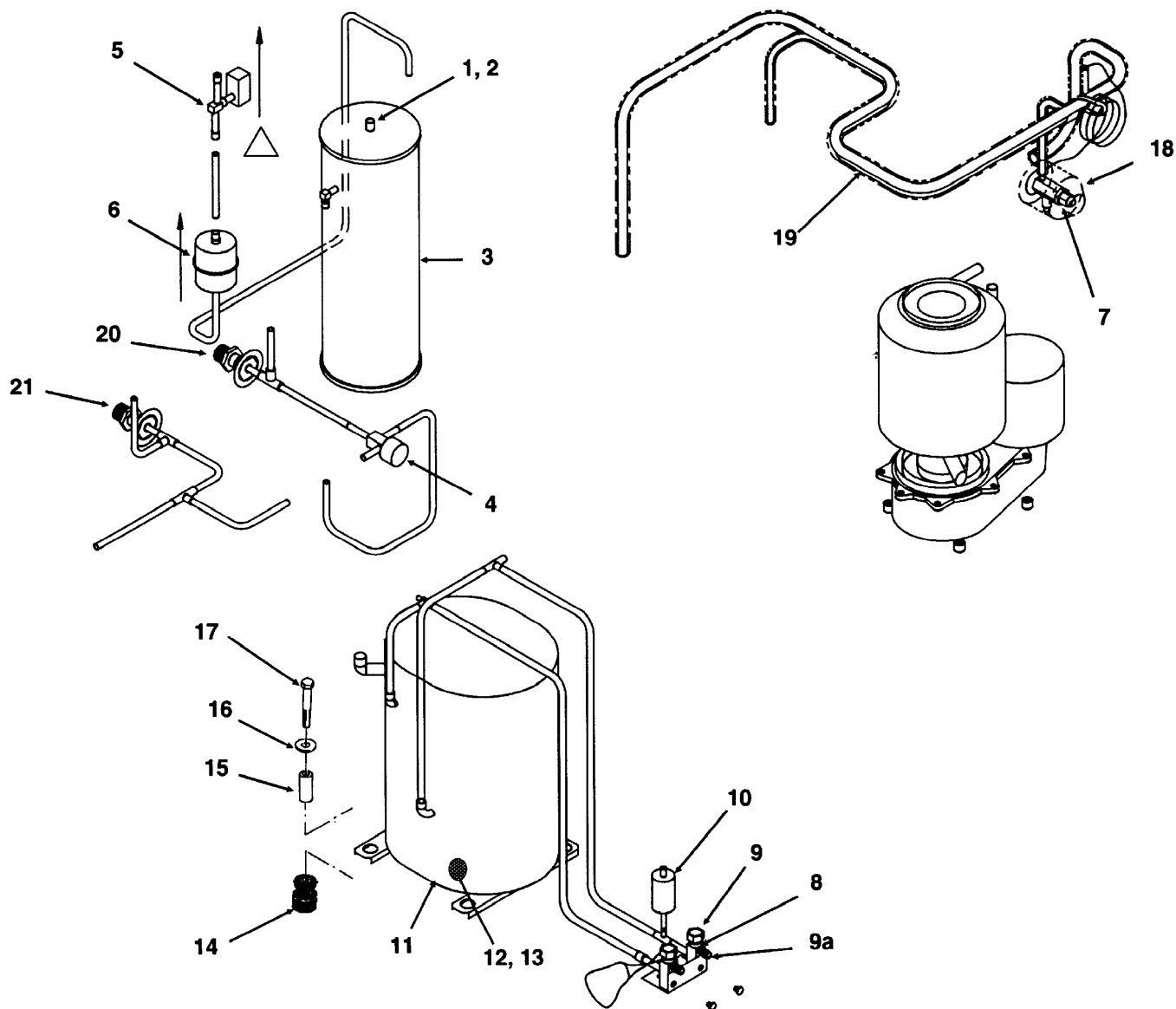

ITEM NUMBER	PART NUMBER	DESCRIPTION	ITEM NUMBER	PART NUMBER	DESCRIPTION
1.	03-1406-13	Nut	12.	12-2308-01	Heater
2.	03-1410-06	Washer	13.	12-2309-01	clip
3.	16-0761-01	Receiver	14.	18-2200-28	Grommet
4.	11-0422-25	Lo Temp Valve	15.	18-2200-27	Sleeve
5.	12-2135-22	Liquid Line Valve	16.	03-1407-07	Washer
6.	02-3319-02	Drier	17.	03-1405-20	Bolt
7.	11-0482-21	Thermo. Exp. Valve	18.	A31961-020	TXV insulation
8.	16-0832-20	Access valve	19.	no number	Suction line
9.	16-0832-02	Stem cap	20.	16-0850-03	Quick connect, 3/8"
9a.	16-0832-03	Core cap	21.	16-0850-01	Quick connect, 1/2"
10.	11-0485-21	High Press. Switch	Not shown, parts to attach receiver:		
11.	18-8726-23	Compressor 208-230/60/1 (includes item 12)		03-1645-01	Screw
				03-1417-09	Washer
				A31801-002	Lower Bracket

FME1500R SERVICE PARTS EVAPORATOR

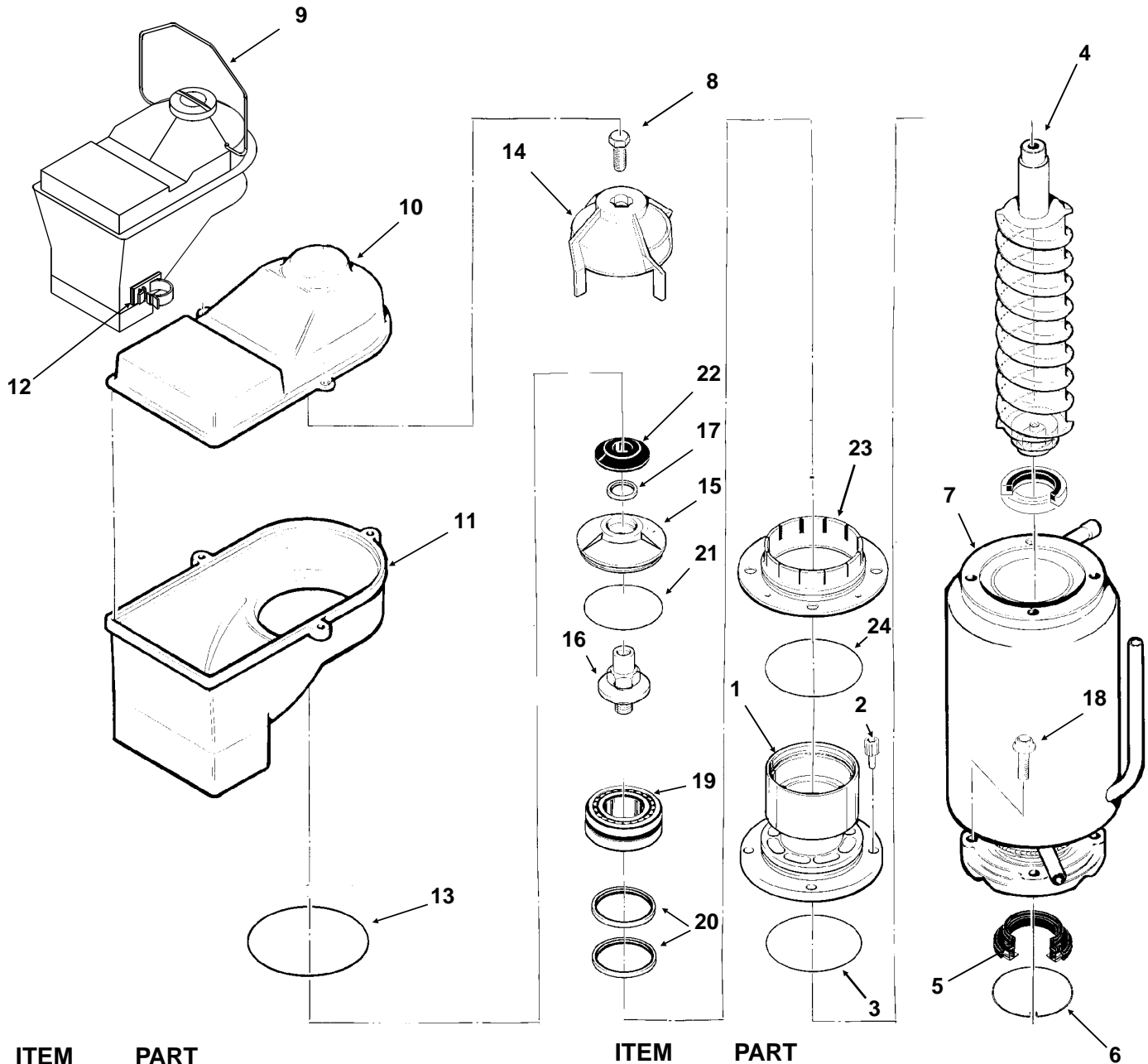

ITEM NUMBER	PART NUMBER	DESCRIPTION
1.	A34505-020	Breaker Includes Items 19 & 20
2.	03-1544-08	Soc. head Screw
3.	13-0617-45	O-ring
4.	02-3003-01	Auger
5.	02-0929-03	Water Seal
6.	A32777-001	Ring, Water Seal
7.	A32890-020	Evaporator
8.	03-1405-52	Hex Cap Screw
9.	A34969-001	Bail clamp
10.	02-2930-04	Ice Chute Cover
11.	02-3841-01	Ice Chute Body

ITEM NUMBER	PART NUMBER	DESCRIPTION
12.	02-3268-01	Drain hose clip
13.	13-0617-52	O-ring
14.	02-3001-01	Ice Sweep
15.	02-3128-01	Breaker Cover
16.	08-0660-01	Auger Stud
17.	02-2978-01	Lip Seal
18.	03-1420-03	Cap screw
19.	A34559-020	Bearing
20.	02-2977-01	Lip Seal
21.	13-0617-54	O-Ring
22.	13-0871-01	Water Shed
23.	02-2916-01	Slotted collar
24.	13-0617-49	O-ring

Note: Evaporator is not available assembled with internal parts.

FME1500R SERVICE PARTS GEARMOTOR

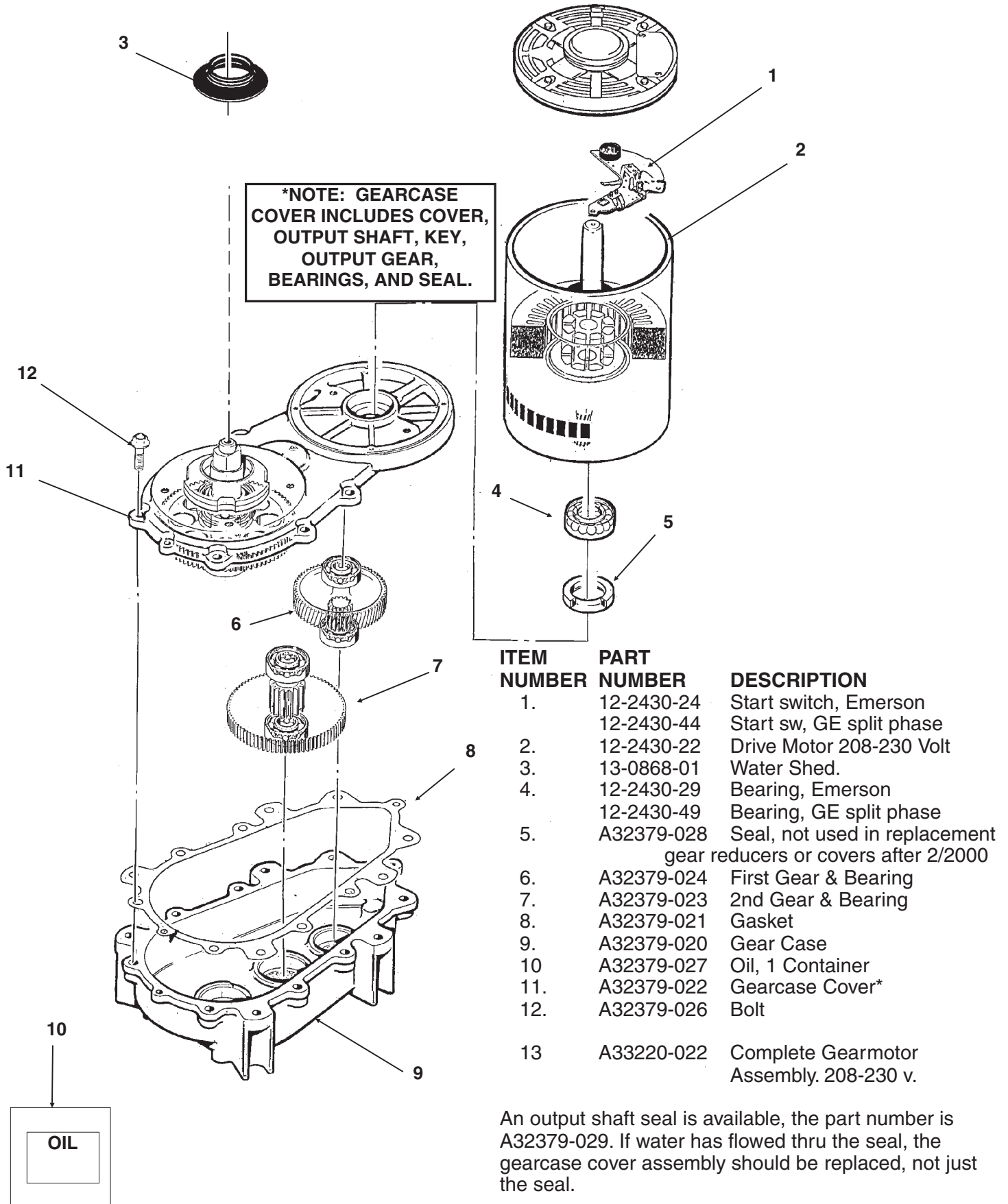

An output shaft seal is available, the part number is A32379-029. If water has flowed thru the seal, the gearcase cover assembly should be replaced, not just the seal.

FME1500R SERVICE PARTS

RESERVOIR, DRAINS, ICE CHUTE, ICE LEVEL SENSORS

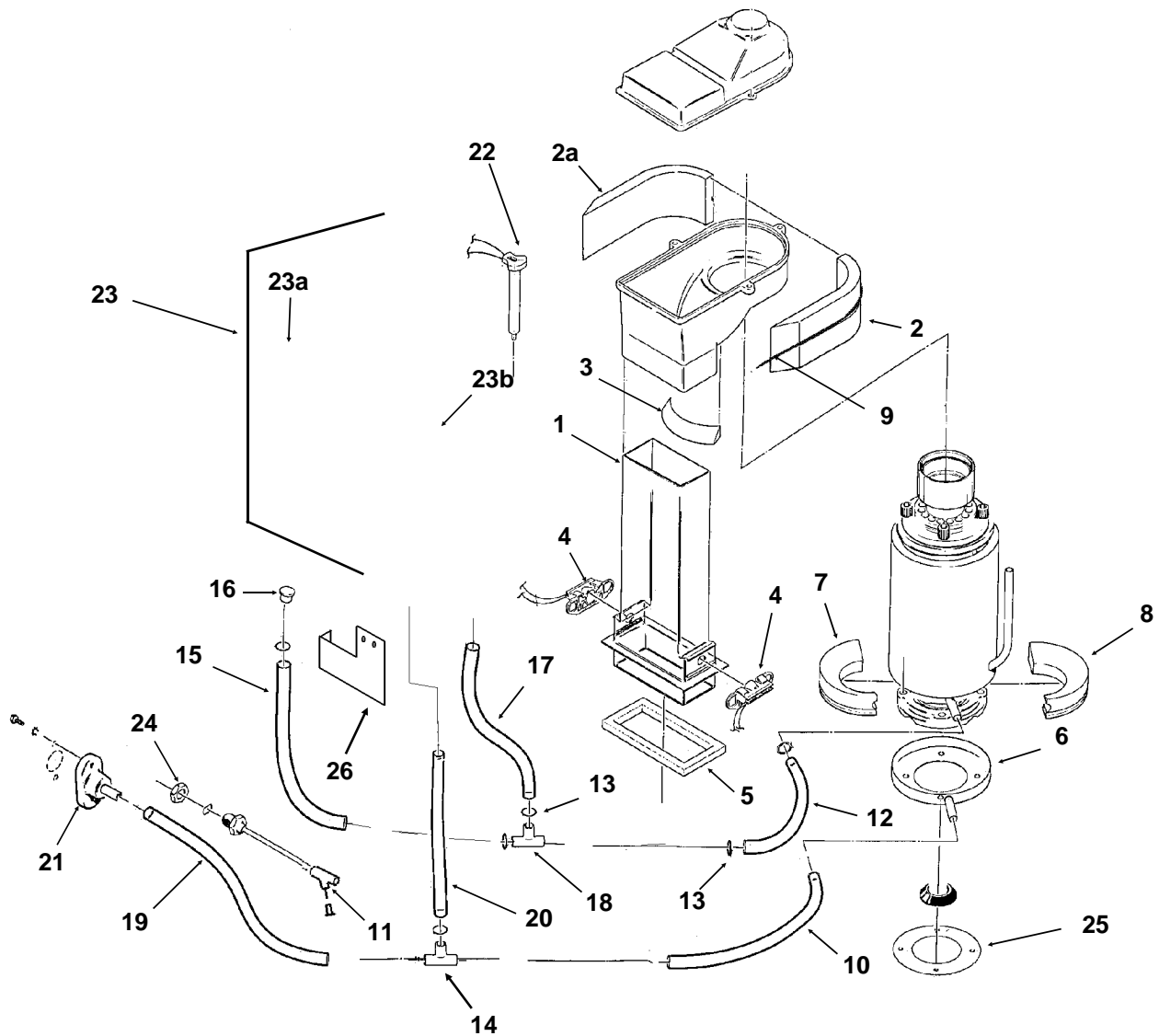

ITEM NUMBER	PART NUMBER	DESCRIPTION	ITEM NUMBER	PART NUMBER	DESCRIPTION
1.	02-2929-04	Ice Chute Lower	16.	13-0840-01	Plug
2.	A32963-001	Insulation collar, top	17.	13-0674-06	Tube, 9" Order By Ft.
2a	A32963-002	Insulation collar, top	18.	16-0670-02	Tee
3.	A33102-001	Insulation Collar Inside	19.	13-0079-03	Tube, 18" Order By Ft.
4.	A33117-020	Ice level sensor set	20.	13-0079-03	Tube, 12" Order By Ft.
5.	A32930-001	Chute Gasket	21.	02-3692-22	Drain
6.	A32050-001	Drip Pan	22.	A33101-022	Thermo Probe
7.	A32962-001	Insulation Collar Bottom	23.	02-3266-20	Float & Reservoir complete
8.	A32962-002	Insulation Collar Bottom	23a	02-3266-22	Seat/plunger
9.	A35419-020	Strap kit	23b	02-3266-21	Float valve
10.	13-0079-03	Hose 9" Order By Ft.	24.	03-1394-01	Pal Nut
11.	16-0162-00	Strainer	25.	13-0704-00	Drip pan gasket
12.	A33203-001	Preformed Hose	26.	.A35956-001	Reservoir bracket
13.	02-2814-08	Hose Clamp			
14.	16-0670-01	Tee			
15.	13-0674-06	Tube, 11" Order By Ft.			

FME1500R SERVICE PARTS REMOTE CONDENSER

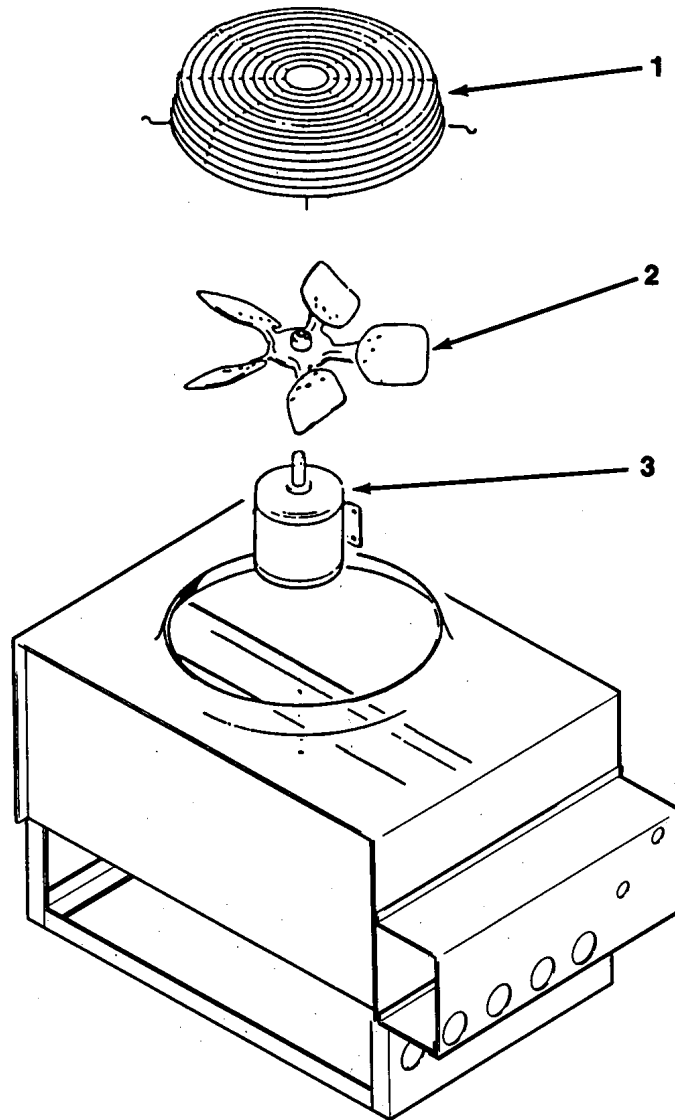

RCE651-32A or RCE652-32A

ITEM NUMBER	PART NUMBER	DESCRIPTION
1.	02-2618-01	Fan Guard
2.	18-6304-01	Fan Blade
3.	18-5301-01	Fan Motor

ERC201 or ERC402

ITEM NUMBER	PART NUMBER	DESCRIPTION
1	02-3575-01	Fan guard
2	18-8800-01	Fan blade
3	18-8796-32	Fan motor

For precharged line set:

16-0701-02	Female coupling (3/8")
16-0701-10	Female coupling (1/2")

FME1500R SERVICE PARTS

Component Layout Diagram

208-230/60/1

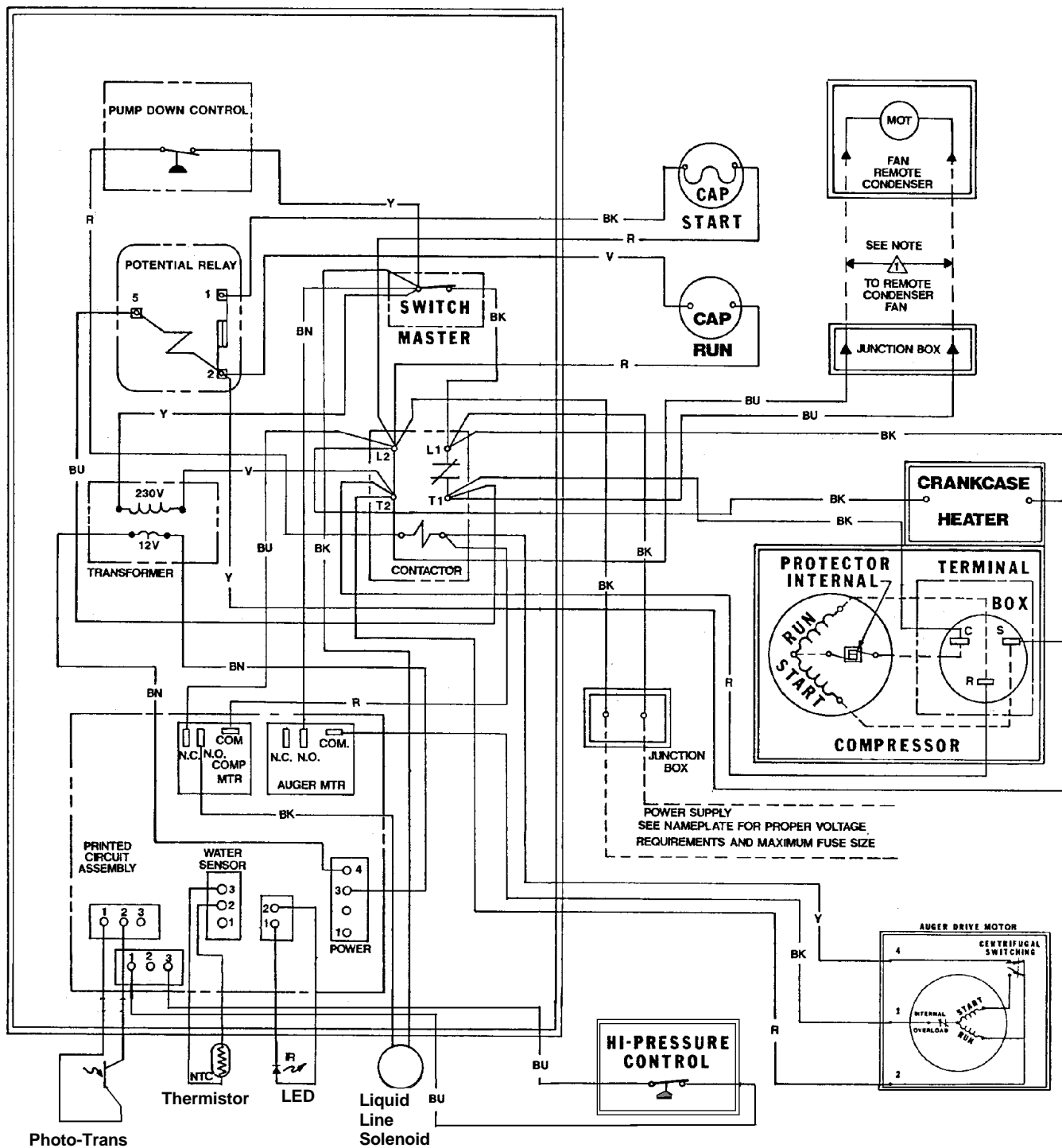

FME1500R SERVICE PARTS

Schematic Diagram

208-230/60/1

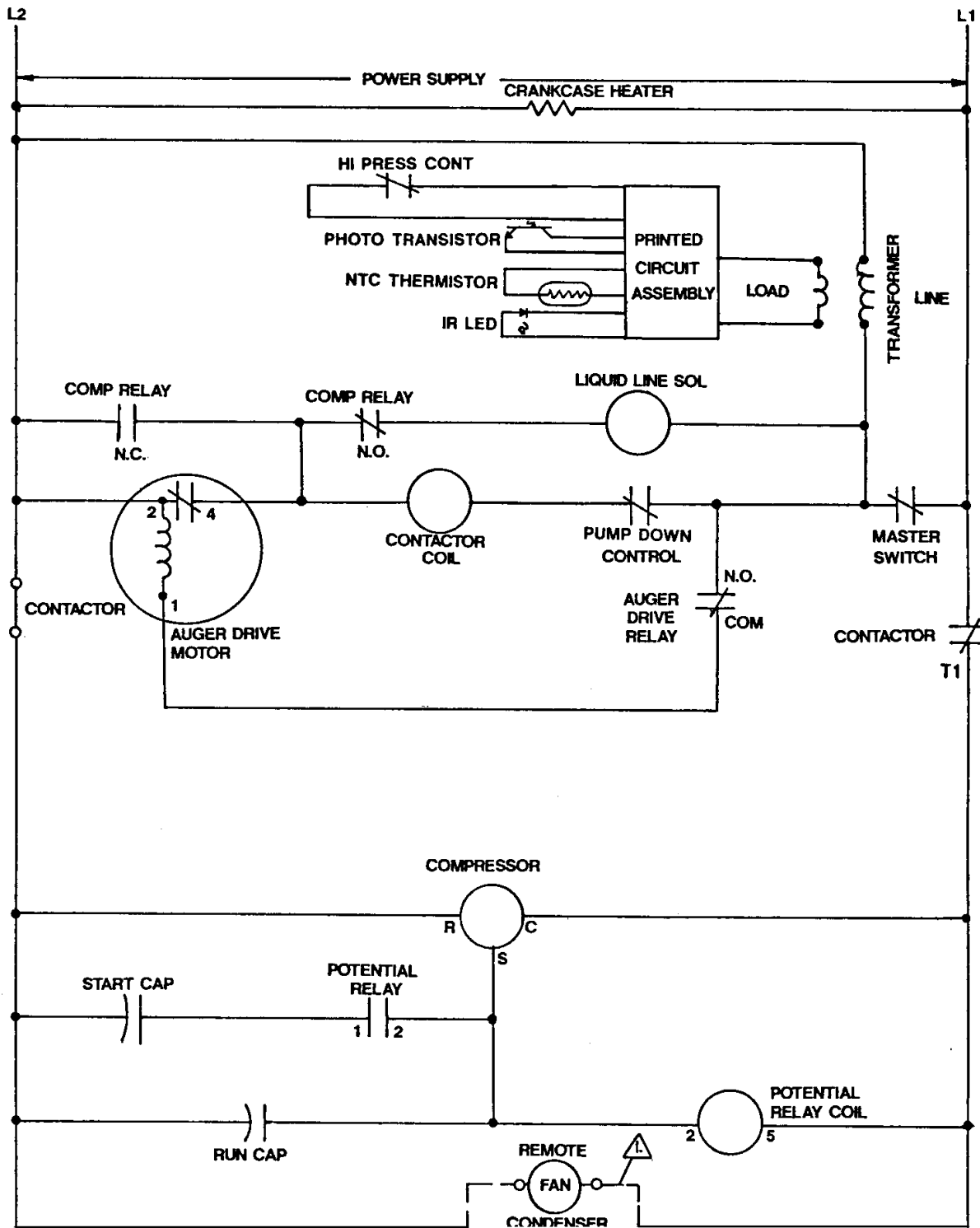

USE COPPER CONDUCTOR ONLY THIS UNIT MUST BE GROUNDED

All controls shown in Normal Ice Making Mode

Note: Dashed lines indicate field wiring which must be installed in accordance with the National Electric Code using a minimum of 14 ga. awg. wire.