

FM2402 SERVICE PARTS

This parts list contains the service parts and wiring diagrams for this model. Check the model number in question to be sure that it is applicable to this parts list.

TABLE OF CONTENTS

Cabinet	2
Air Cooled Refrigeration	3
Water Cooled Refrigeration.....	4
Water System	5
Gearmotor.....	6
Evaporator	7
Control Box.....	8
Wiring Diagrams	9

FM2402 SERVICE PARTS

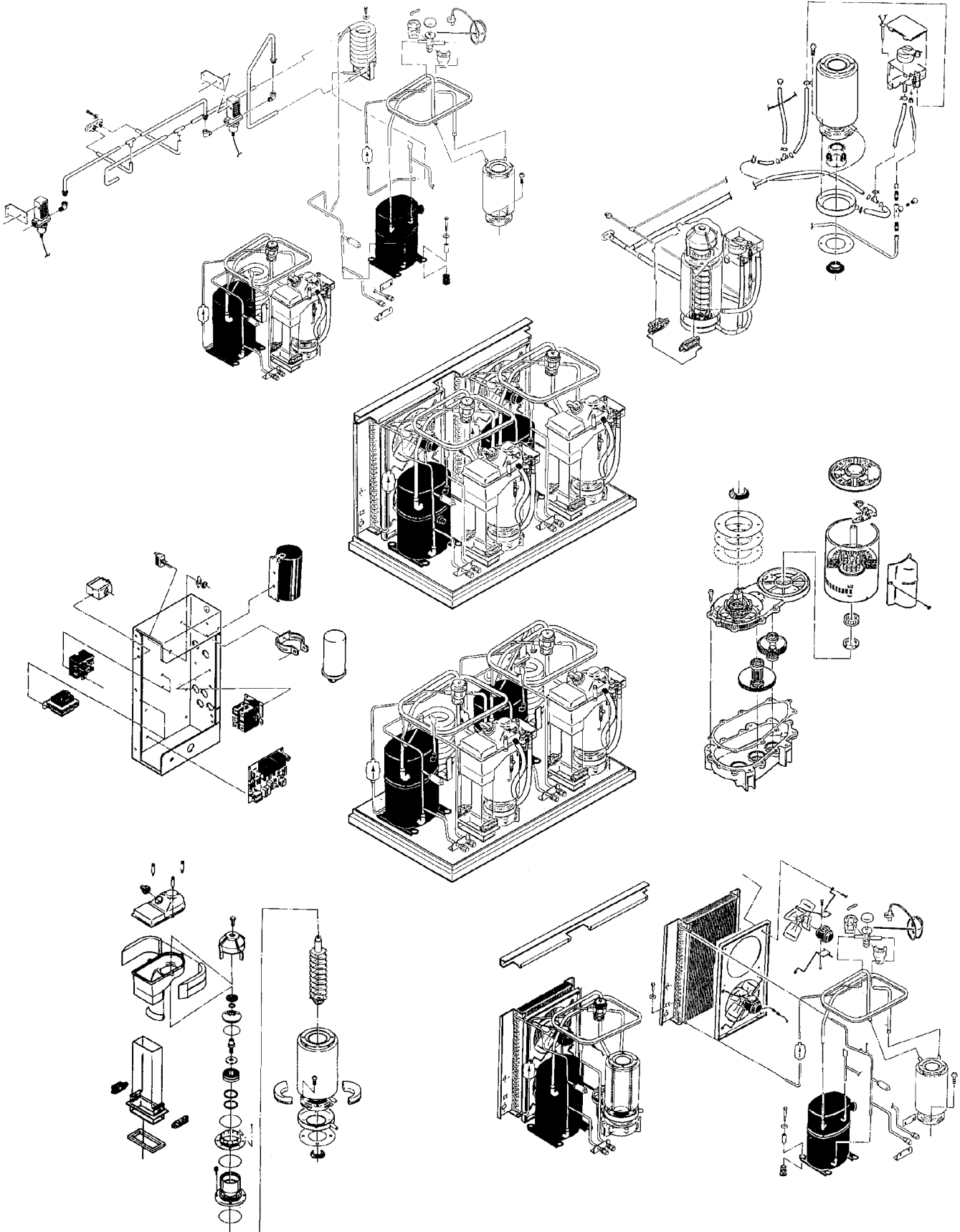

FM2402 SERVICE PARTS Cabinet Assembly

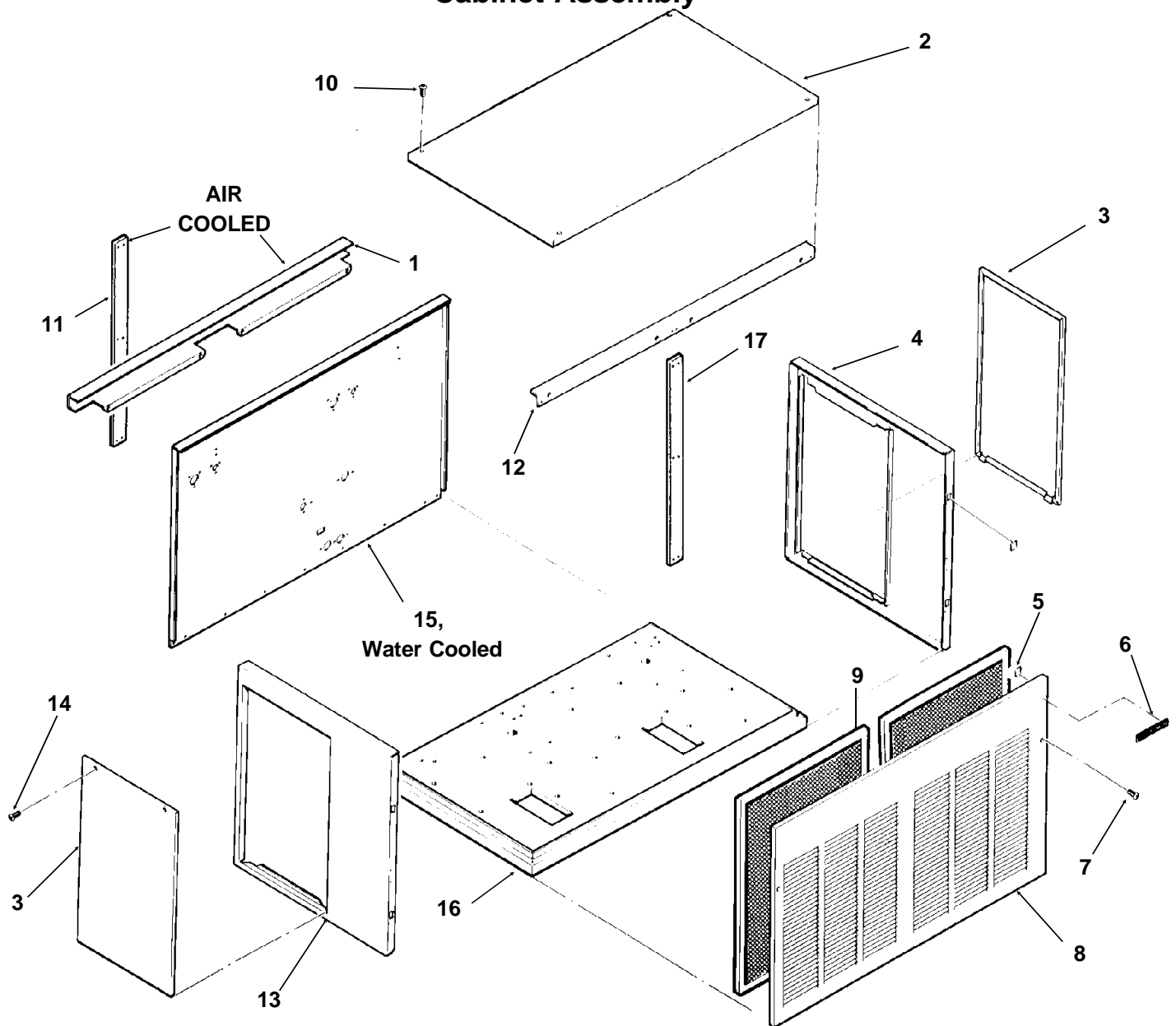

ITEM NUMBER	PART NUMBER	DESCRIPTION	ITEM NUMBER	PART NUMBER	DESCRIPTION
1	A34284-001	Condenser Support	9	02-2976-01	Filter Assembly (1)
2	A32461-001	Top Panel, Painted	10	03-1531-01	Screw
	A32461-002	Top Panel, S.S.	11	A34285-001	Filler Plate, Air Cooled
3	A34038-001	Service Panel, Painted	12	A34287-001	Support
	A34038-002	Service Panel, S.S.	13	A32435-001	Left Side Panel, Painted
4	A33292-001	Right Side Panel, Painted		A32435-002	Left Side Panel, S.S.
	A33292-002	Right Side Panel, S.S.	14	03-1404-12	Screw
5	03-0271-00	Speed Clip	15	A34283-001	Rear Panel, Water Cooled
6	15-0711-01	Emblem			Painted Only
7	03-1419-08	Screw	16.	A34282-001	Base
8	A34294-001	Front Panel, Painted	17.	A34286-001	Center Support
	A34294-002	Front Panel, S.S.			

FM2402 SERVICE PARTS

Air Cooled Refrigeration

NOTE: 60 cycle replacement Compressors include a crankcase heater which was not part of the original design. The crankcase heater may be used or disconnected.

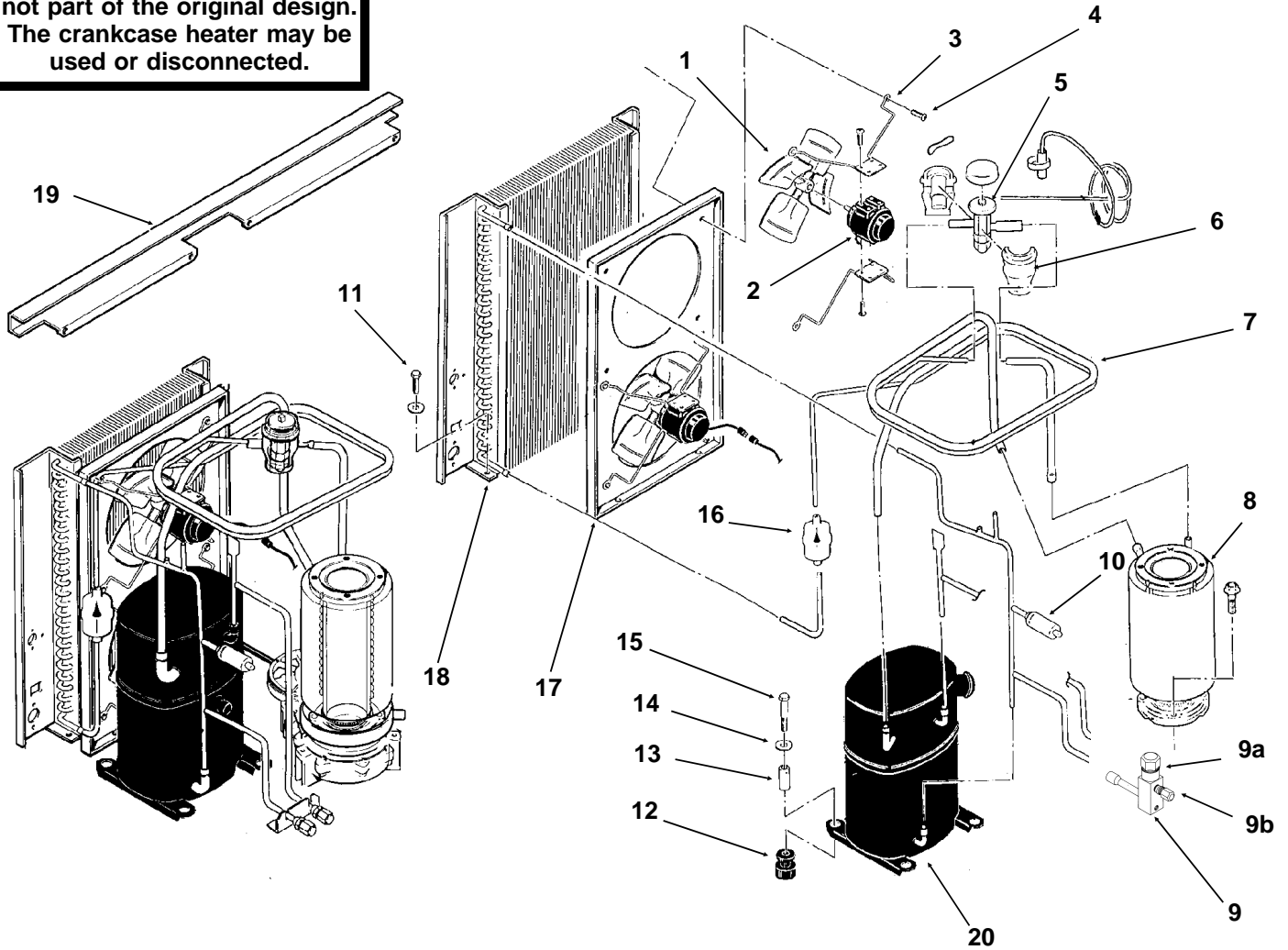

ITEM NUMBER	PART NUMBER	DESCRIPTION	ITEM NUMBER	PART NUMBER	DESCRIPTION
1	18-3815-01	Fan Blade	12	18-6800-01	Grommet
2	12-1576-02	Fan Motor	13	18-2300-27	Sleeve
3	02-2378-01	Fan Bracket	14	03-1407-07	Washer
4	03-1531-01	Screw	15	03-1405-20	Cap Screw
5	A32961-020	Insulation Kit (3 piece)	16	02-3319-02	Dryer
6	11-0477-20	Thermo Expansion Valve	17	A33231-001	Fan Shroud
7	A34050-001	Suction Line	18	18-8717-01	Condenser
8	A32890-020	Evaporator	19	A34284-001	Condenser Support
9	16-0832-20	Access valve	20	18-8716-23	Compressor 208-230/60/1
9a	16-0832-02	Stem cap		18-8716-25	Compressor 200-230/60/3
9b	16-0832-03	Core cap		18-8716-26	Compressor 220-240/50/1
10	11-0446-27	Hi Pressure Cut Out	(all have internal overloads & 18-8716-03, 18-8716-05 have crankcase heaters)		
11	03-1645-01	Screw			

FM2402 SERVICE PARTS

Water Cooled Refrigeration

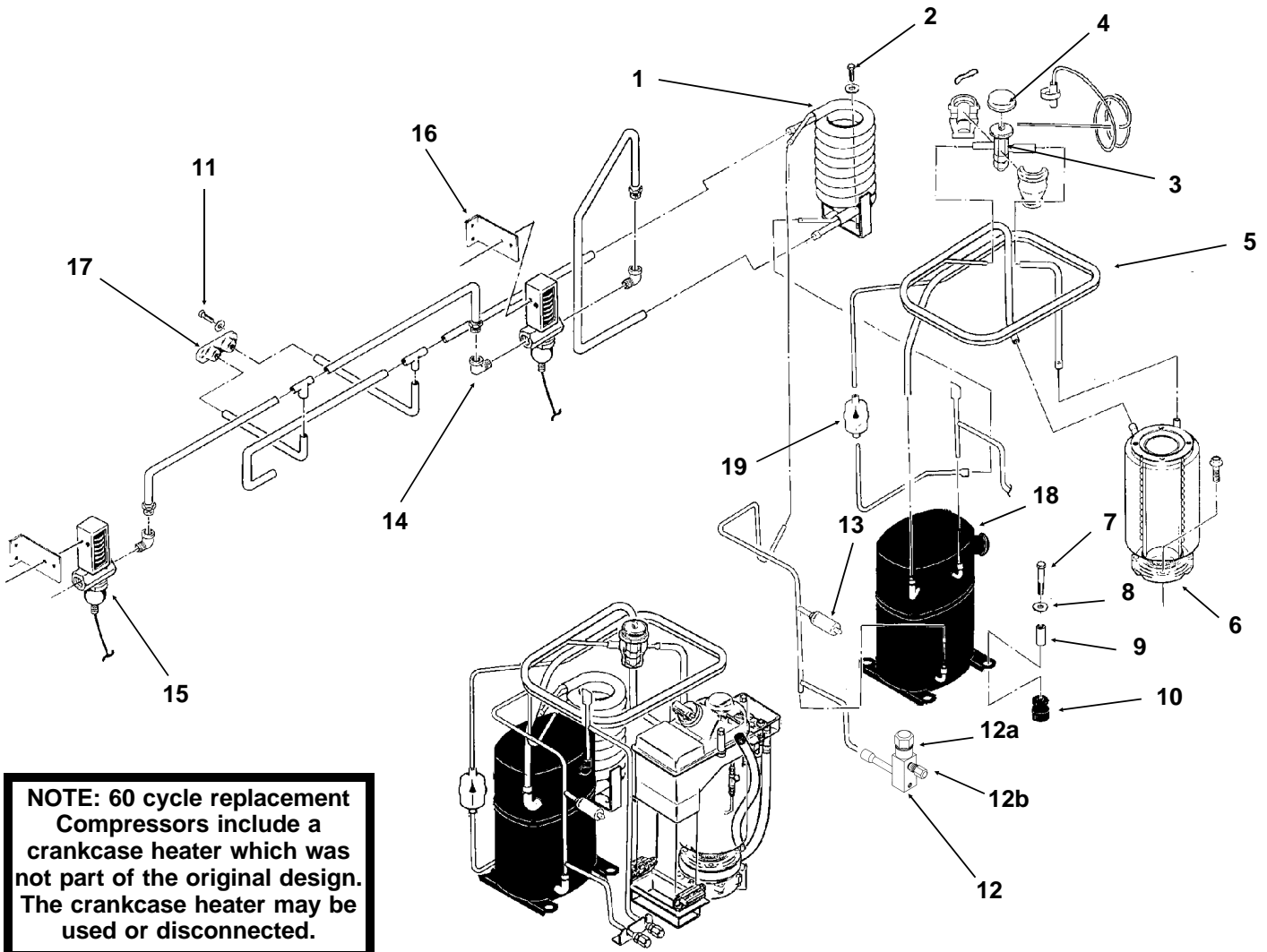

NOTE: 60 cycle replacement Compressors include a crankcase heater which was not part of the original design. The crankcase heater may be used or disconnected.

ITEM NUMBER	PART NUMBER	DESCRIPTION
1	18-8718-01	Condenser
2	03-1645-01	Screw
3	11-0477-20	Thermo Expansion Valve
4	A32961-020	Insulation Kit (3 piece)
5	A35566-001	Suction Line
6	A32890-020	Evaporator
7	03-1405-20	Cap Screw
8	03-1407-07	Washer
9	18-2300-27	Sleeve
10	18-6800-01	Grommet
11	03-1645-01	Screw
12	16-0832-20	Access valve
12a	16-0832-02	Stem cap
12b	16-0832-03	Core cap
13	11-0446-27	Hi Pressure Cut Out
14	16-0401-02	Elbow
15	11-0424-01	Water Reg. Valve
16	A34341-001	Bracket
17	A34291-001	Drain Assembly
18	18-8716-23	Compressor 208-230/60/1
	18-8716-25	Compressor 200-230/60/3
	18-8716-26	Compressor 220-240/50/1
(all have internal overloads & 60 cycle compressors have crankcase heaters)		
19	02-3319-02	Dryer

FM2402 SERVICE PARTS

Water System

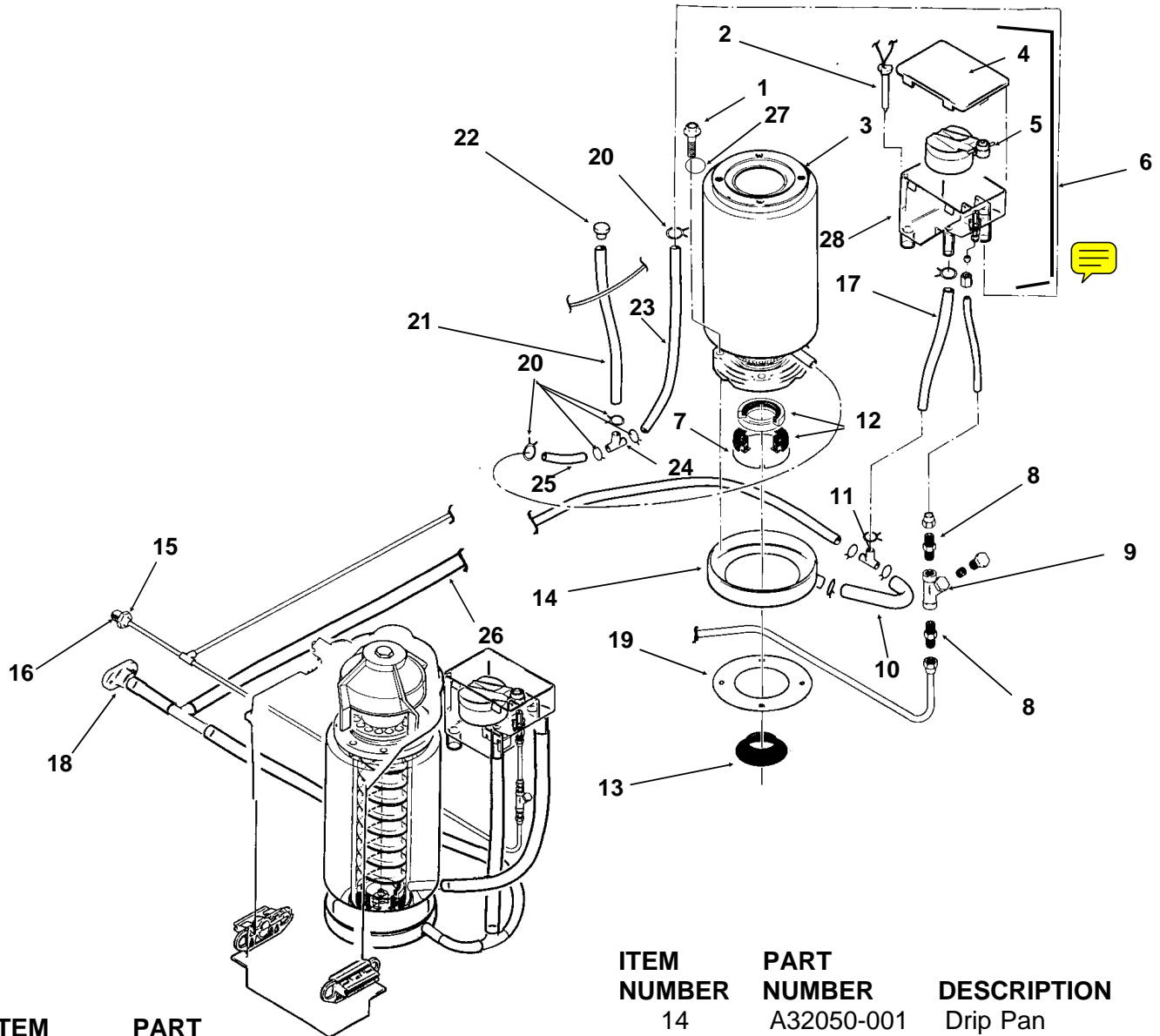

ITEM NUMBER	PART NUMBER	DESCRIPTION
1	03-1420-03	Cap Screw
2	A33101-022	Water Level Sensor
3	A32890-020	Evaporator
4	02-2936-01	Res. Cover
5	A32907-001	Float Assembly with pin housing seal, rubber seal, insert & float
6	A32929-020	Reservoir Assy Complete
7	A32777-001	Retaining Ring for seal
8	16-0791-01	Half Union
9	16-0162-00	Strainer
10	13-0079-03	Tube, 6.5" req.
11	16-0670-02	Tee
12	02-0929-23	Water Seal
13	13-0868-01	Water Shed

ITEM NUMBER	PART NUMBER	DESCRIPTION
14	A32050-001	Drip Pan
15	A27318-001	Water Inlet Fitting
16	03-1394-01	Pal Nut
17	13-0079-03	Res. Overflow, 8" req.
18	A32282-001	Drain Casting, air cooled
19	13-0704-00	Gasket
20	02-2814-08	Clamps
21	13-0674-06	Evap. Drain, 14" req.
22	13-0840-01	Plug
23	13-0674-06	Evap. Inlet Tube, 5" req.
24	16-0670-01	Tee
25	A33203-001	Tube, Preformed
26	13-0079-03	Drain Tube, 24" req.
27	03-1417-13	Lockwasher
28	13-0230-00	Rubber cap
29	02-2814-01	Clamp

FM2402 SERVICE PARTS

Gearmotor

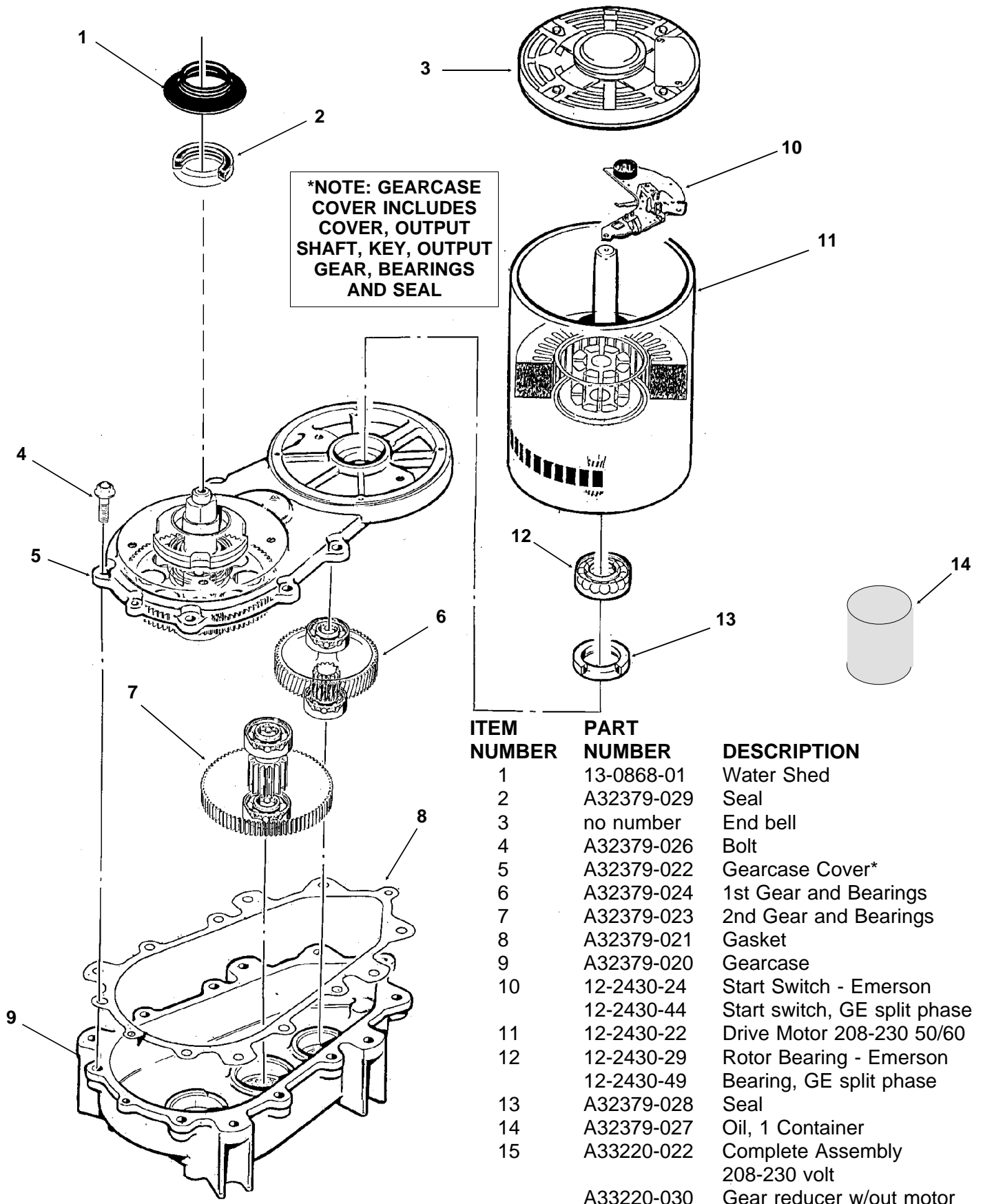

FM2402 SERVICE PARTS

Evaporator

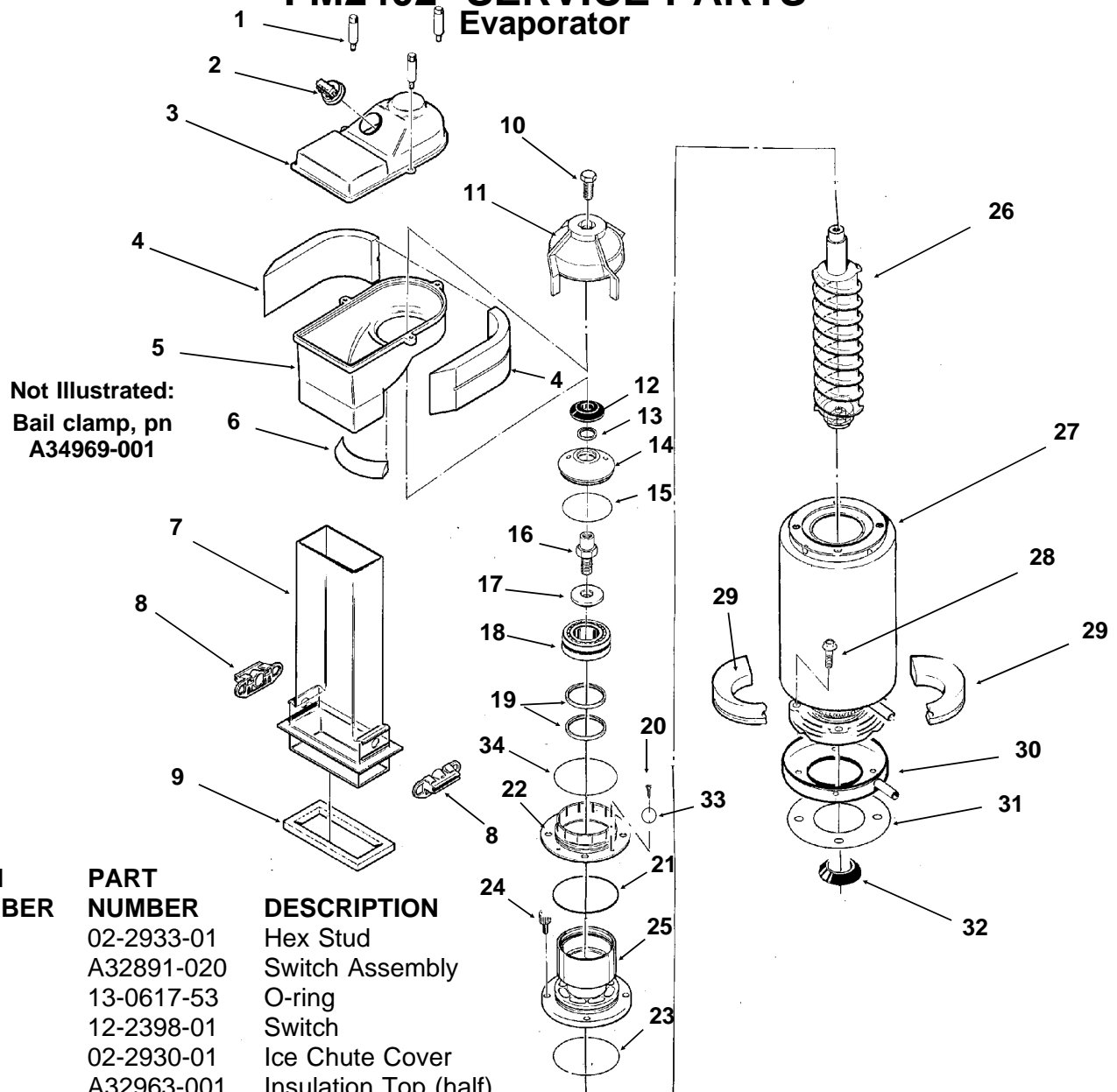

ITEM NUMBER	PART NUMBER	DESCRIPTION
1.	02-2933-01	Hex Stud
2.	A32891-020	Switch Assembly
	13-0617-53	O-ring
	12-2398-01	Switch
3.	02-2930-01	Ice Chute Cover
4.	A32963-001	Insulation Top (half)
5.	02-2926-01	Ice Chute Body
6.	A33102-001	Insulation Collar Inside
	A35419-020	Strap kit
7.	02-2929-01	Ice Chute Lower
8.	A37708-021	Bin Controls Assy. (set of 2)
9.	A32930-001	Chute Gasket
10.	03-1405-52	Hex Cap Screw
11.	02-3001-01	Ice Sweep
12.	13-0871-01	Water Shed
13.	02-2978-01	Lip Seal
14.	02-3128-01	Breaker Cover
15.	13-0617-54	O-Ring
16.	08-0660-01	Auger Stud, includes #17
17.	no number	Washer, part of #16
18.	A34559-020	Bearing
19.	02-2977-01	Lip Seal
20.	03-1405-27	Screw
21.	13-0617-52	O-Ring
22.	02-2916-01	Slotted Collar
23.	13-0617-45	O-Ring
24.	03-1544-08	Soc. Head Screw
25.	A34505-020	Breaker (Divider) (includes 18 & 19)
26.	A38071-022	Auger
27.	A32890-020	Evaporator
28.	03-1420-03	Cap Screw
29.	A32962-001	Insulation Bot. (half)
30.	A32050-001	Drip Pan
31.	13-0704-00	Drip Pan Gasket
32.	13-0868-01	Water Shed
33.	03-1408-36	Washer
34.	13-0617-49	O-Ring

FM2402 SERVICE PARTS

Control Box

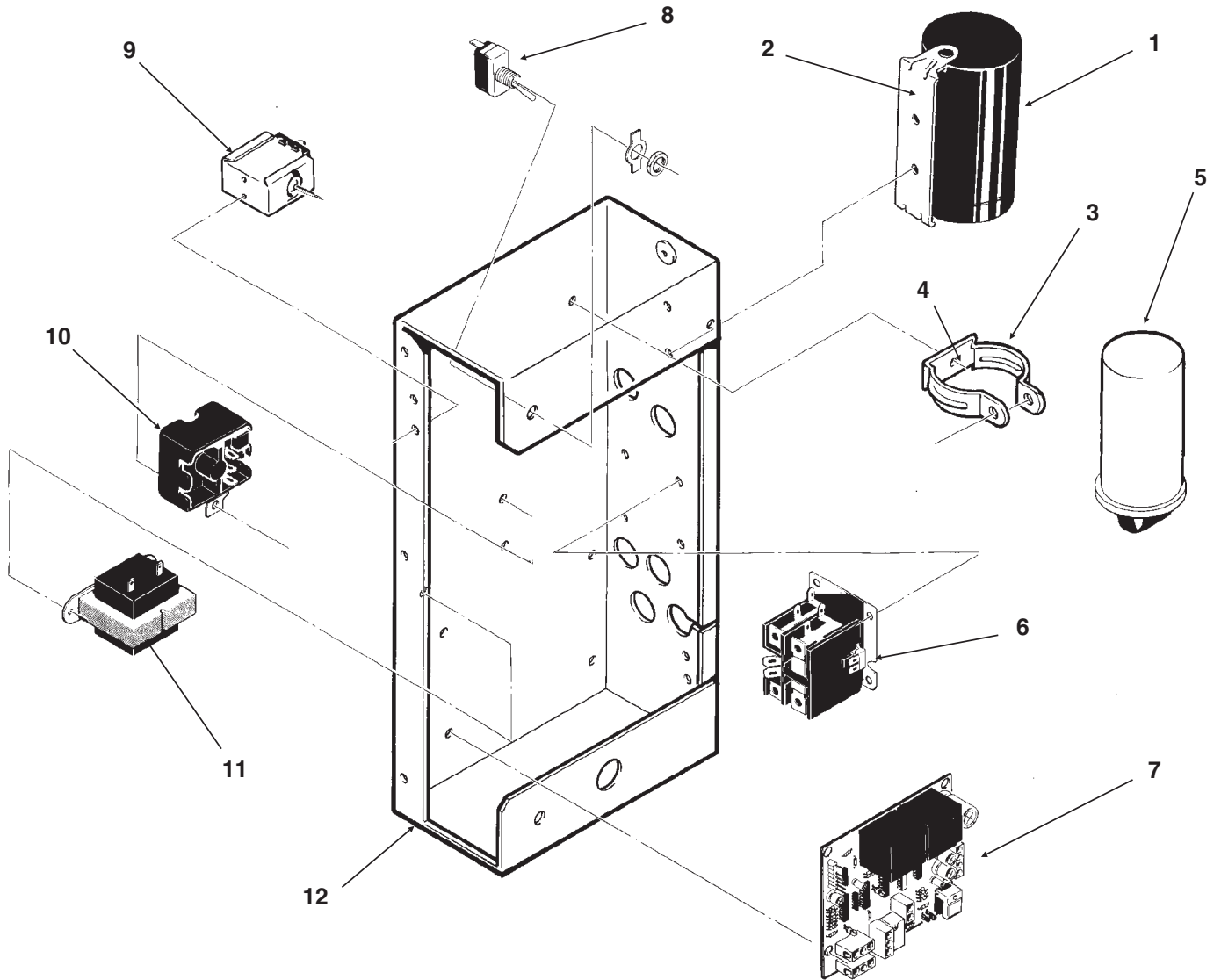

ITEM NUMBER	PART NUMBER	DESCRIPTION	ITEM NUMBER	PART NUMBER	DESCRIPTION
1	18-1901-15	Start Capacitor, 60 HZ	7	A37750-021	Circuit Board
	18-1901-23	Start Capacitor, 50 HZ	8.	12-0426-01	Master Switch
	18-2200-38	Start Capacitor Cap.	9.	11-0447-20	Low Pressure Control
2.	18-2200-39	Start Capacitor Bracket	10	18-1903-33	Potential Relay 60 HZ
	03-1638-04	Screw		18-1903-46	Potential Relay, 50 HZ
	03-1417-15	Lockwasher	11.	12-2285-22	Transformer
3.	A32872-001	Run Cap Bracket	12	no number	Control Box
	03-1652-02	Bolt	NOT ILLUSTRATED		
	03-0255-04	Wing Nut	13.	12-2337-02	3 Pin Plug Assy (Safety Circuit to Circuit Board)
4.	03-1638-03	Screw	14.	12-2340-01	4 Pin Plug Assy (Transformer to Circuit Board)
5.	18-1902-53	Run Capacitor, all	15	A34055-001	Control Box Cover
6.	12-2469-02	Single Phase Contactor			
	12-0739-02	Three Phase Contactor			

Note: HZ means cycles, 50 HZ is 50 cycle. The model number ends in -6 for 50 HZ models.

FM2402 SERVICE PARTS

AIR AND WATER COOLED, 208-230/60/1

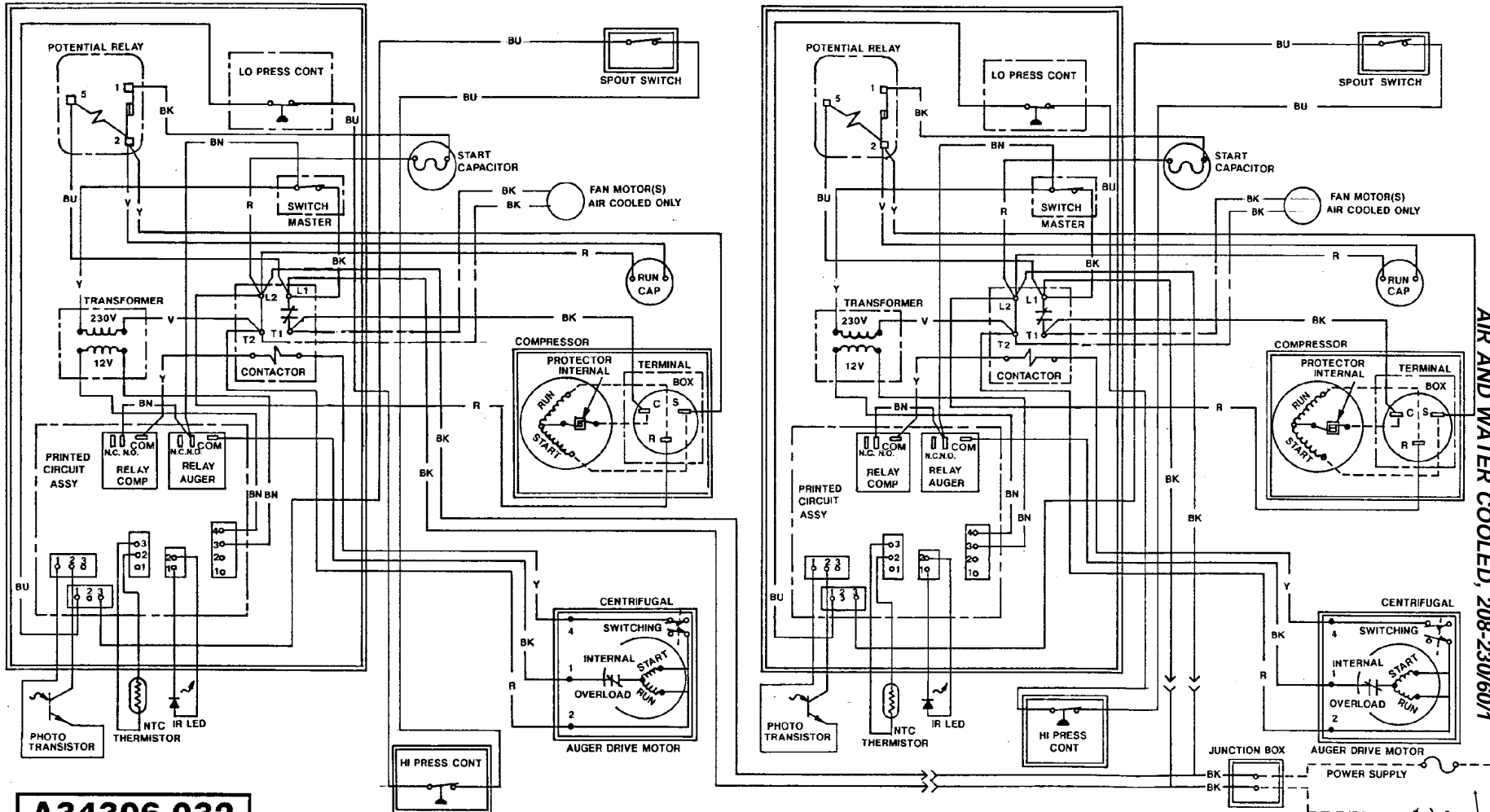

A34306-032

THIS UNIT MUST BE GROUNDED

POWER SUPPLY
SEE NAMEPLATE FOR
PROPER
REQUIREMENTS AND
MAX FUSE SIZE.
ALL POWER LEADS
MUST BE FUSED

FM2402 SERVICE PARTS

AIR AND WATER COOLED, 208-230/60/1

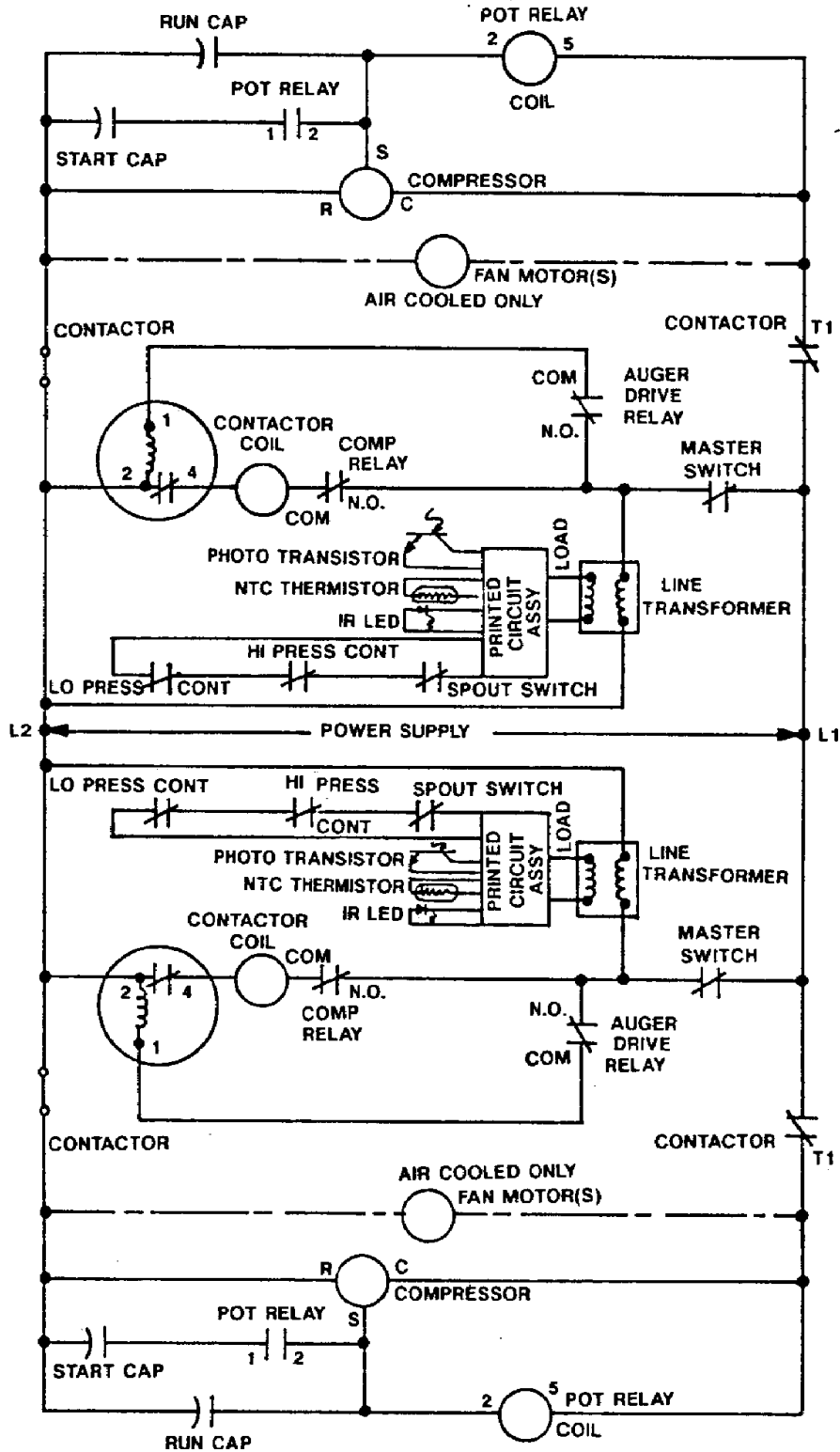

USE COPPER CONDUCTORS ONLY
ALL CONTROLS SHOWN IN NORMAL ICEMAKING MODE
THIS UNIT MUST BE GROUNDED

FM2402 SERVICE PARTS

AIR AND WATER COOLED, 208-230/60/3

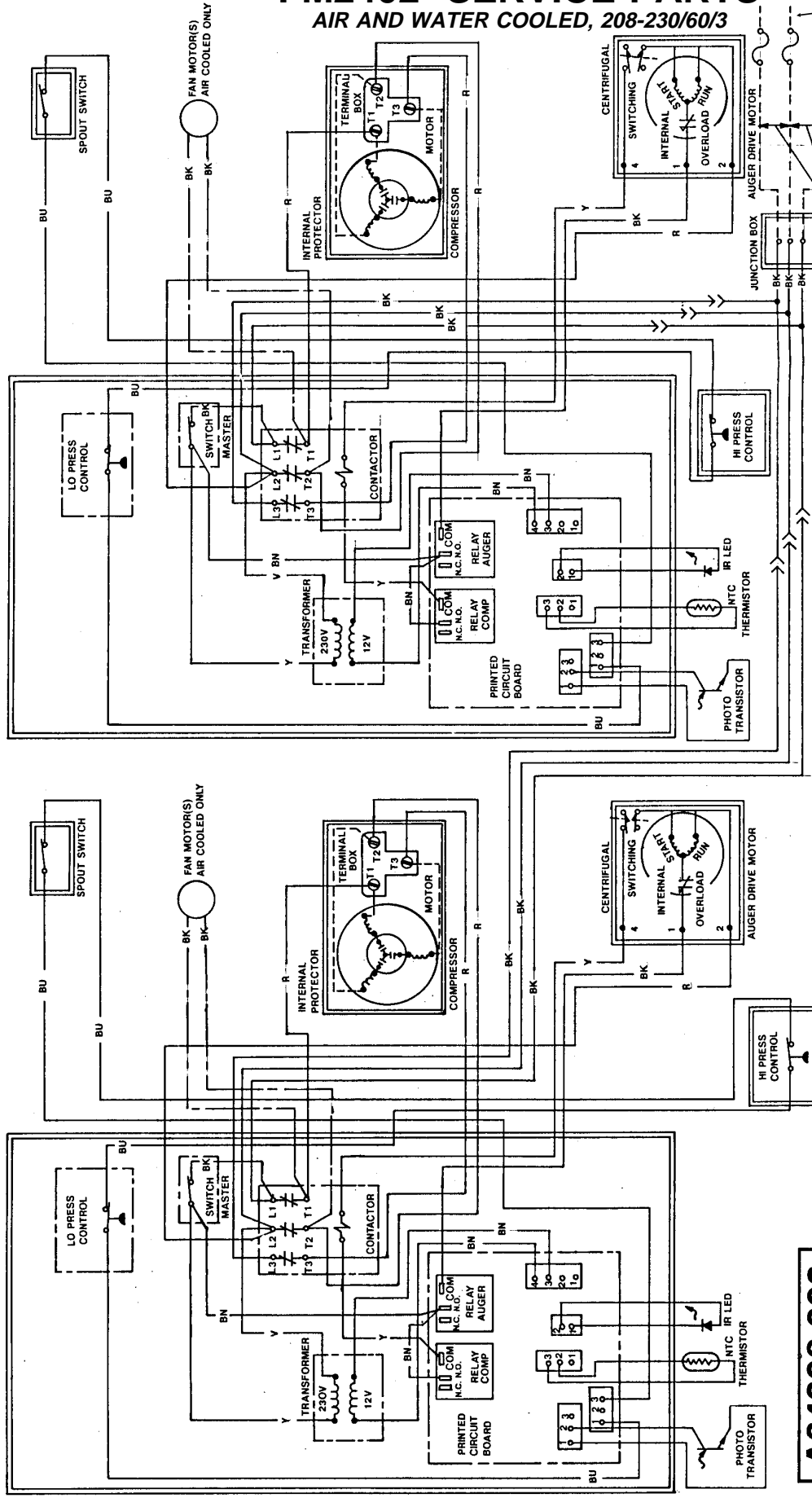

SEE NAMEPLATE FOR PROPER VOLTAGE REQUIREMENTS AND MAX FUSE SIZE

POWER SUPPLY
ALL POWER LEADS
MUST BE FUSED

A34306-003

FM2402 SERVICE PARTS

AIR AND WATER COOLED, 208-230/60/3

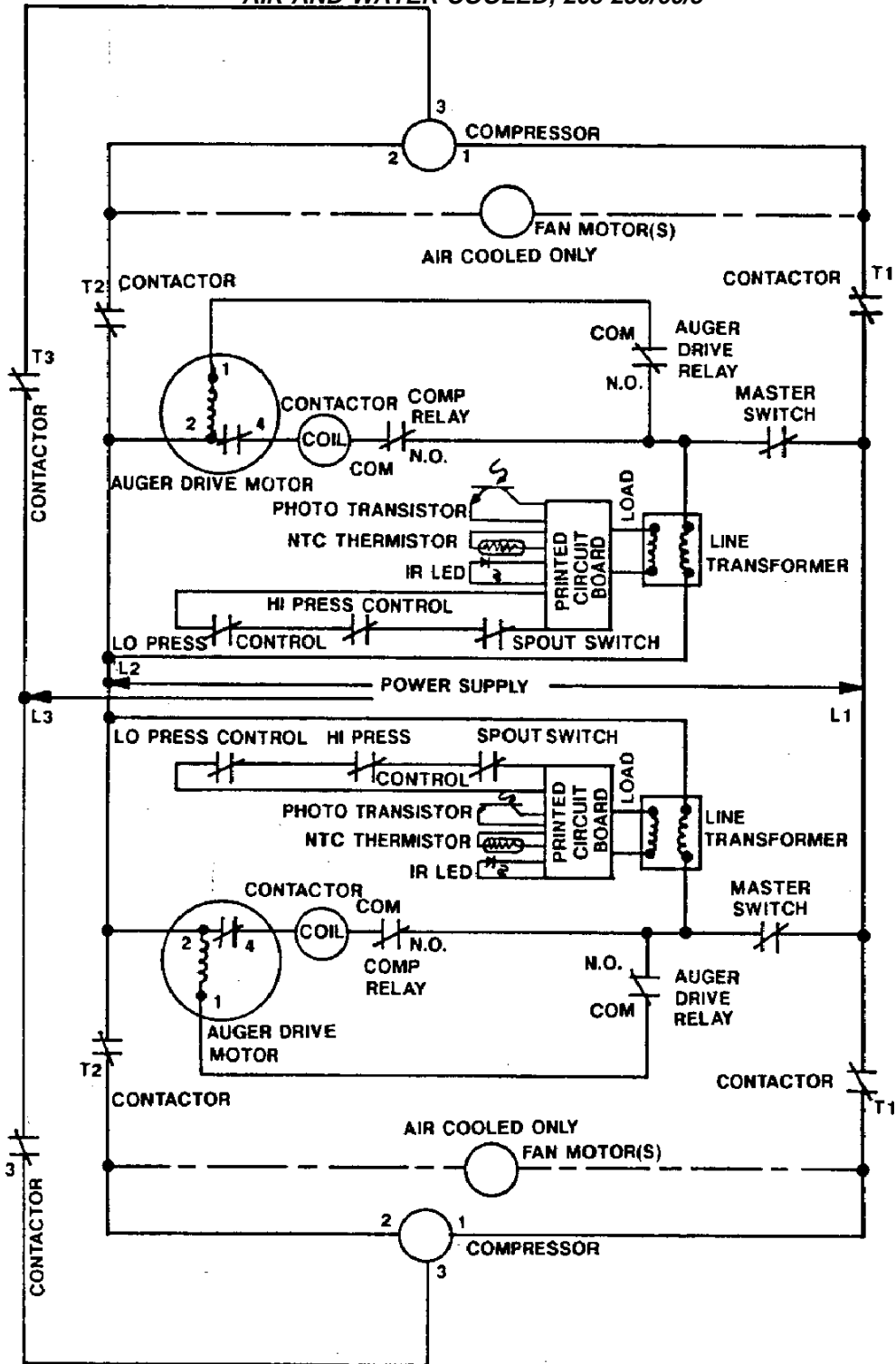

USE COPPER CONDUCTORS ONLY
ALL CONTROLS SHOWN IN NORMAL ICEMAKING MODE
THIS UNIT MUST BE GROUNDED