

CME1356R and CME1656R Service Parts

This parts list contains the part numbers and description of the replacement parts available for these two models.

They have been manufactured in both 50 and 60 Hz, plus there have been model series changes from A, to C and to D.

To avoid costly and time consuming errors, double check the model and voltage before ordering a part.

Table of Contents

Cabinet	page 2
Water System	page 3
Refrigeration System	page 4
Electrical	page 5
ERC411	page 6
BH900	page 7
BH1356	page 8
Kit Parts	page 9
Wiring Diagrams	page 10

CME1356R and CME1656R Service Parts

Cabinet

Note: Front panels changed from two 24" panels to one 48" panel (with top trim strip) in March 1999

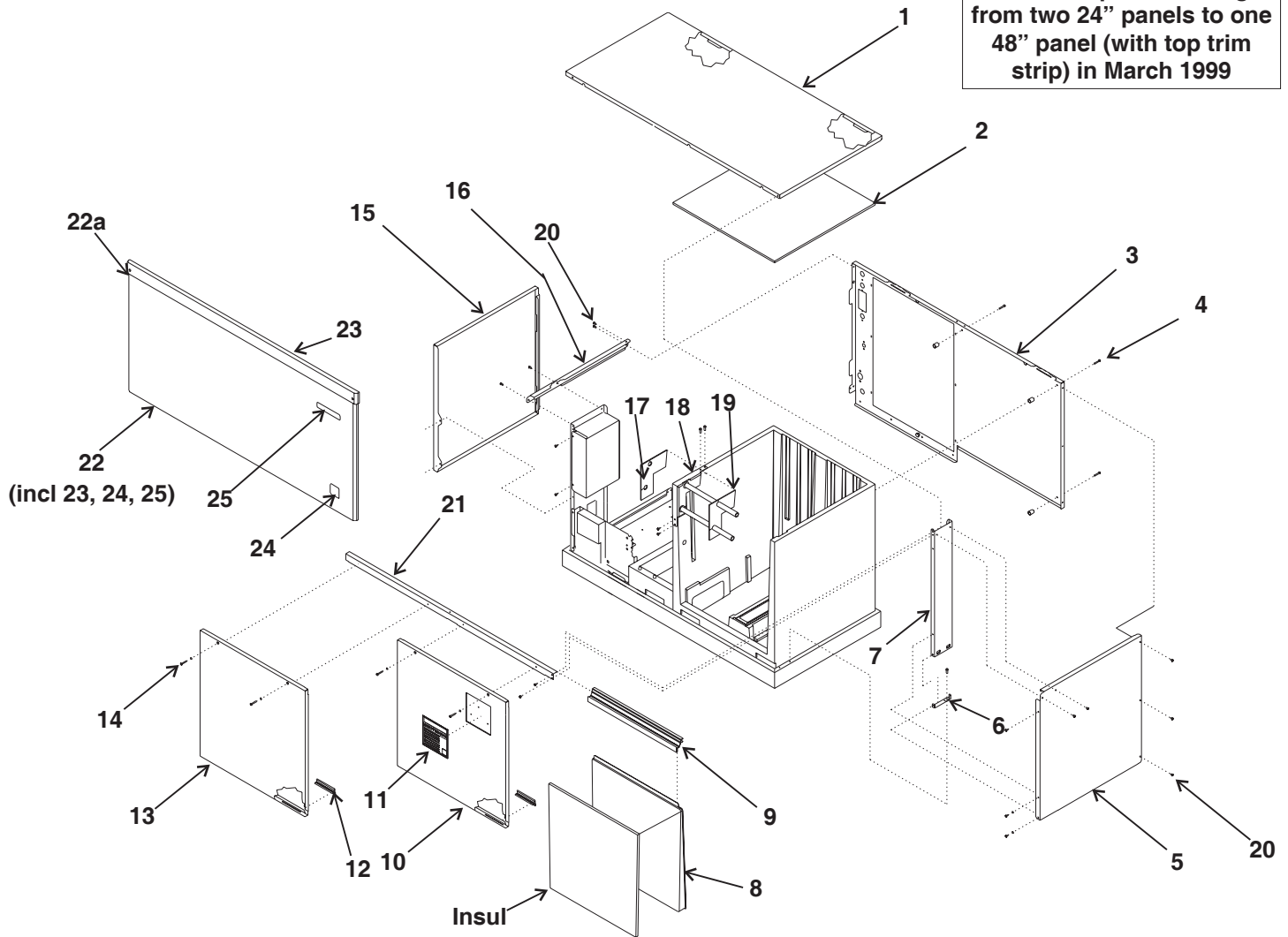

Item Number	Part Number	Description	Item Number	Part Number	Description
1	A37202-015	Top panel, Grey	13	A37201-015	Left front panel, grey
	A37202-002	Top panel, SS		A37201-002	Left front panel, SS
	02-3823-21	Top panel, plastic for C and D series. Will not fit A or B series.	14	03-1735-01	Front panel screw
2	02-3686-01	Insulation	15	A37198-015	Left side panel, grey
3	A37197-001	Back panel for A or B series	16	A37198-002	Left side panel, SS
	A37671-001	Back panel for C or D series	17	A37193-001	Left side channel
4	03-1404-37	Screw	18	02-3696-03	Left grommet
5	A37199-015	Rt side panel, grey, A or B	19	A37216-001	Bracket
	A37199-002	Rt side panel, SS, A or B	20	02-3696-02	Right grommet
	A37668-001	Rt side panel, C or D series	21	03-1531-01	Screw
6	A37194-001	Right bottom channel	22	A37195-001	Channel, front top
7	A37213-001	Right side support	22a	A37489-001	SS 48" panel
8	02-3702-21	Evaporator cover, w/ ins		A37489-002	Grey 48" panel
9	02-3701-01	Cover retainer	23	03-1735-01	Screw
10	A37200-015	Right front panel, grey	24	02-3794-02	Trim strip
	A37200-002	Right front panel, SS		03-1731-02	Push nut
11	15-0790-01	Emblem	25	15-0792-02	CM ³ emblem
12	02-3699-01	Panel support clip		15-0808-03	Scotsman Emblem
				03-0271-00	Speed nut for emblems #24 & 25

CME1356R and CME1656R Service Parts

Water System

Item Number	Part Number	Description
-------------	-------------	-------------

1	02-3613-01	Elbow
2	02-3520-01	Elbow, rt. 1356
3	13-0617-48	O-ring
4	02-3518-01	Manifold
5	02-3519-01	Manifold right, 1656
6	13-0840-01	Plug
7	02-2527-01	Water distributor
8	A37315-021	Evaporator
9	02-3725-01	Hose clamp
10	02-3672-01	Right trough, 1656 only
11	02-3672-02	Left trough
12	A37337-001	Evap support
13	11-0540-21	Ice sensor (set)
14	02-3337-02	Ice deflector
15	02-3706-01	Upper inner splash panel

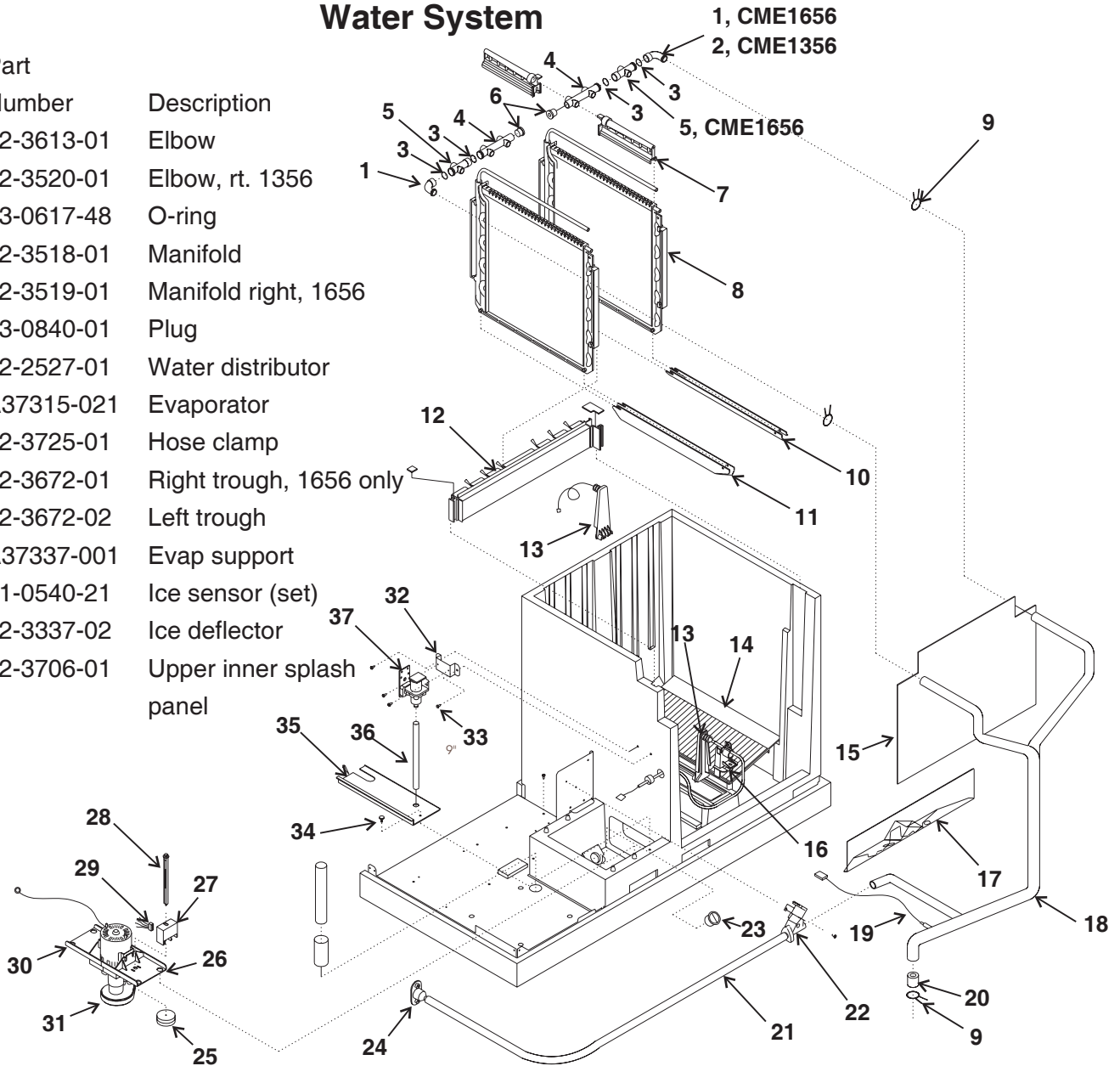

16	02-3689-01	Ice sensor holder	27	11-0539-21	Water level sensor
17	02-3680-01	Lower inner splash panel	28	02-3383-04	Float stem, tan for 1356
18	02-3660-02	CME1356 water hose		02-3383-05	Float stem, brown for 1656
	02-3660-01	CME1656 water hose	29	12-2665-01	Harness for water sensor
19	11-0515-21	Temp sensor set	30	02-3388-05	Pump bracket
20	02-3614-01	Flow restrictor, 1356 only. No longer used.	31	12-2582-21	Water pump
21	13-0674-06	Drain hose, order 2 units	32	A37204-001	Bracket
22	11-0514-01	Purge valve	33	03-1404-18	Screw
23	02-3703-01	Drain plug	34	03-1691-01	Nylon screw
24	02-3692-21	Drain fitting	35	02-3534-01	Reservoir cover
25	02-3341-01	Float	36	13-0674-02	Tube, order 1 unit
26	02-3388-04	Pump bracket	37	12-2666-01	Water solenoid valve
				16-0355-00	Coupling half

CME1356R and CME1656R Service Parts

Refrigeration

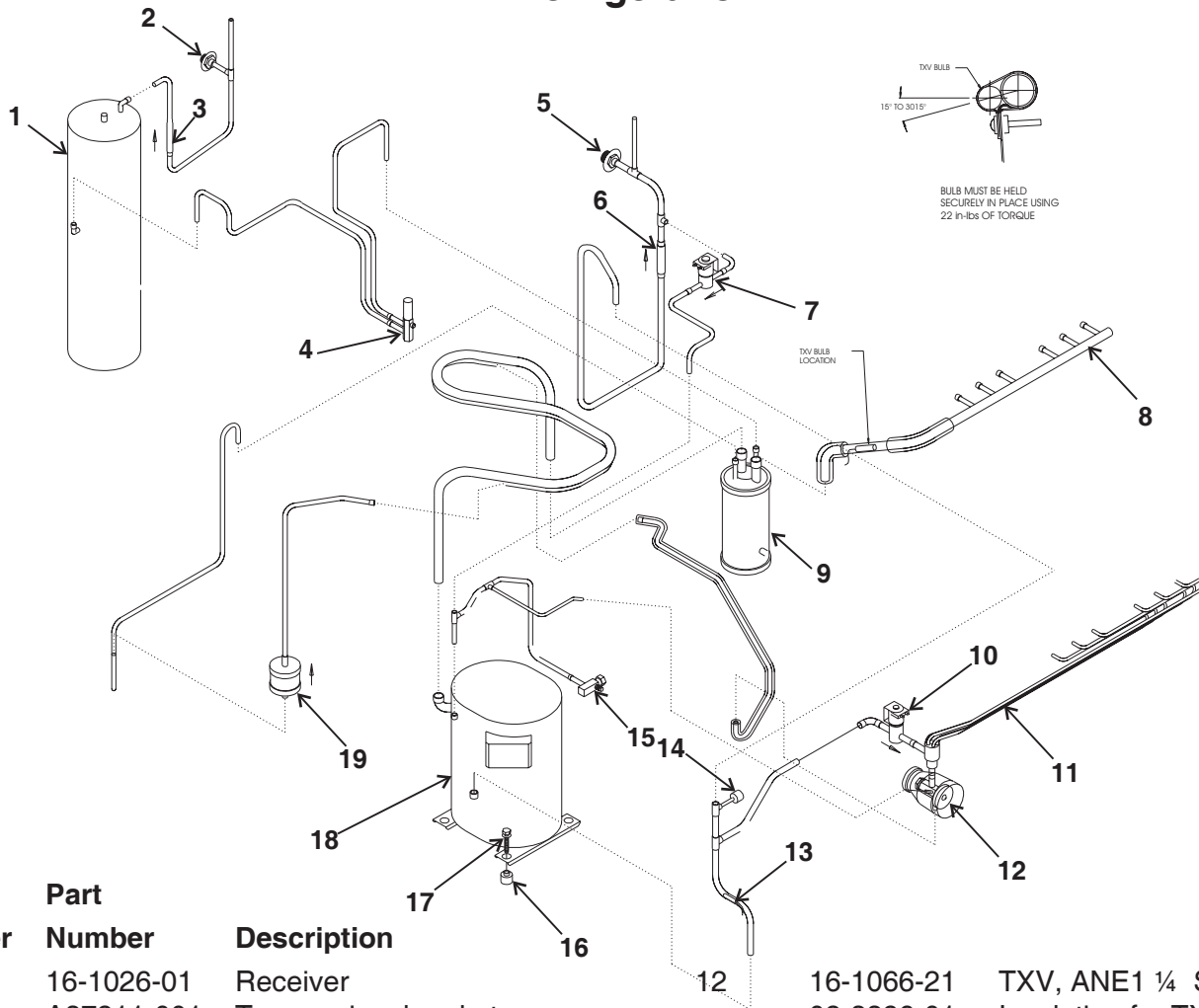

Item Number	Part Number	Description
1	16-1026-01	Receiver
	A37211-001	Top receiver bracket
	A37212-001	Bottom receiver bracket
2	16-0850-03	Liquid line fitting
3	16-1029-01	Liquid line check valve
4	16-1030-01	Liquid line access valve
5	16-0850-01	Discharge line fitting
6	16-1028-01	Discharge check valve
7	11-0513-21	Harvest bypass valve
7a	16-1063-01	Strainer for bypass valve
8	16-1032-02	Suction manifold, 1656
	16-1032-01	Suction manifold, 1356
9	16-0801-22	Accumulator w/insul.
	A37210-001	Accumulator support
10	11-0507-21	Hot gas valve, 1356
	11-0507-22	Hot gas valve, 1656
	12-2719-23	Coil for hot gas valve
	16-1063-03	Strainer for bypass valve
11	A37312-021	Distributor and tubes, 1356
	A37312-022	Distributor and tubes, 1656
12	16-1066-21	TXV, ANE1 ¼ SZ
	02-3396-01	Insulation for TXV
13	11-0515-21	Temp sensor set
14	11-0501-22	Hi pressure cut out
15	16-0832-20	Suction access valve
	16-0832-03	Port cap
	16-0832-02	Stem cap
16	18-2300-27	Grommet
	18-2200-27	Sleeve
17	03-1405-20	Bolt
	03-1407-07	Washer
18	18-8751-23	Compressor, 60 Hz, single phase
	18-8751-25	Compressor, 60 Hz, 3 phase
	18-8751-27	Compressor, 50 Hz, single phase
	Replacement compressors include a crankcase heater (pn 18-2308-01) and a dryer.	
19	02-3319-02	Dryer

CME1356R and CME1656R Service Parts

Electrical

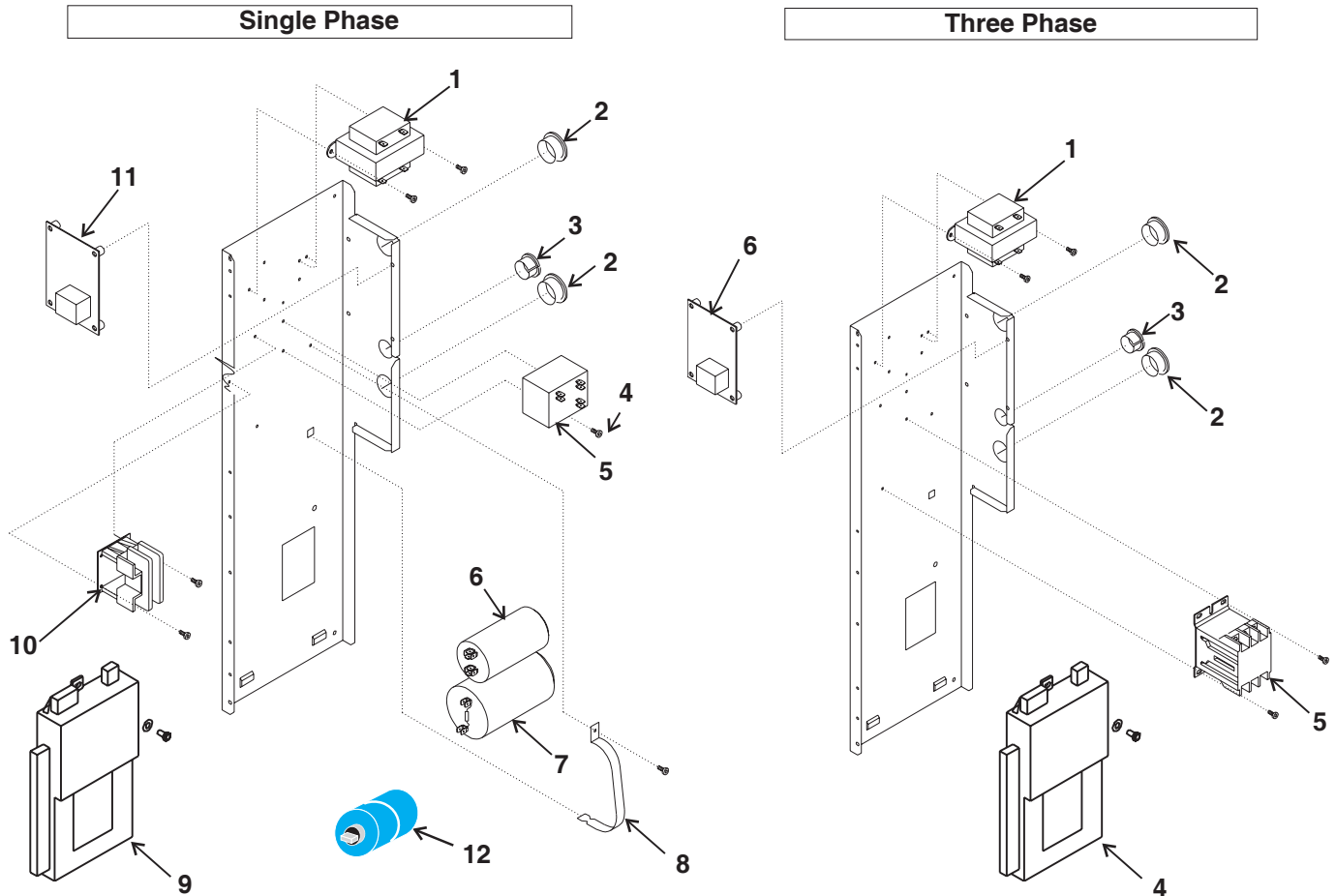

Single Phase

Item Number	Part Number	Description
1	A37217-001	Transformer
2	12-1213-11	Snap bushing
3	12-1213-10	Snap bushing
4	03-1531-01	Screw
5	18-1903-46	60 Hz potential relay
	18-1903-56	50 Hz potential relay
6	18-1902-56	Run capacitor
7	18-1901-27	60 Hz start capacitor
	18-1901-57	50 Hz start capacitor
8	A37125-001	Strap
9	12-2838-23	Controller
10	12-2469-01	Single phase contactor
11	11-0531-22	Purge valve timer kit
12	18-8840-01	PTCR
12a	18-8840-02	Bracket for PTCR

Three Phase

Item Number	Part Number	Description
1	A37217-001	Transformer
2	12-1213-11	Snap bushing
3	12-1213-10	Snap bushing
4	12-2838-23	Controller
5	12-2533-01	Three phase contactor
6	11-0531-22	Purge valve timer kit

Not Shown

11-0521-21	Bin thermostat
02-3740-01	Thermostat bracket
03-1675-03	3 pronged knob
12-2701-01	Bin thermo harness
12-2663-02	Lo voltage harness A-C
12-2660-01	Hi voltage harness A -C
12-2791-02	Low voltage harness, D
12-2797-01	Hi voltage harness, D
12-2679-01	Relay, -6B, -6C, or -6D
12-2686-01	Fuse, -6B, -6C or -6D
12-2639-02	Transformer, -6B, thru -6D
12-2798-01	Hi volt harness, -6B thru -6D
12-2738-02	Lo volt harness, -6B & -6C
12-2792-02	Lo volt harness, -6D

CME1356R and CME1656R Service Parts

ERC411 Remote Condenser

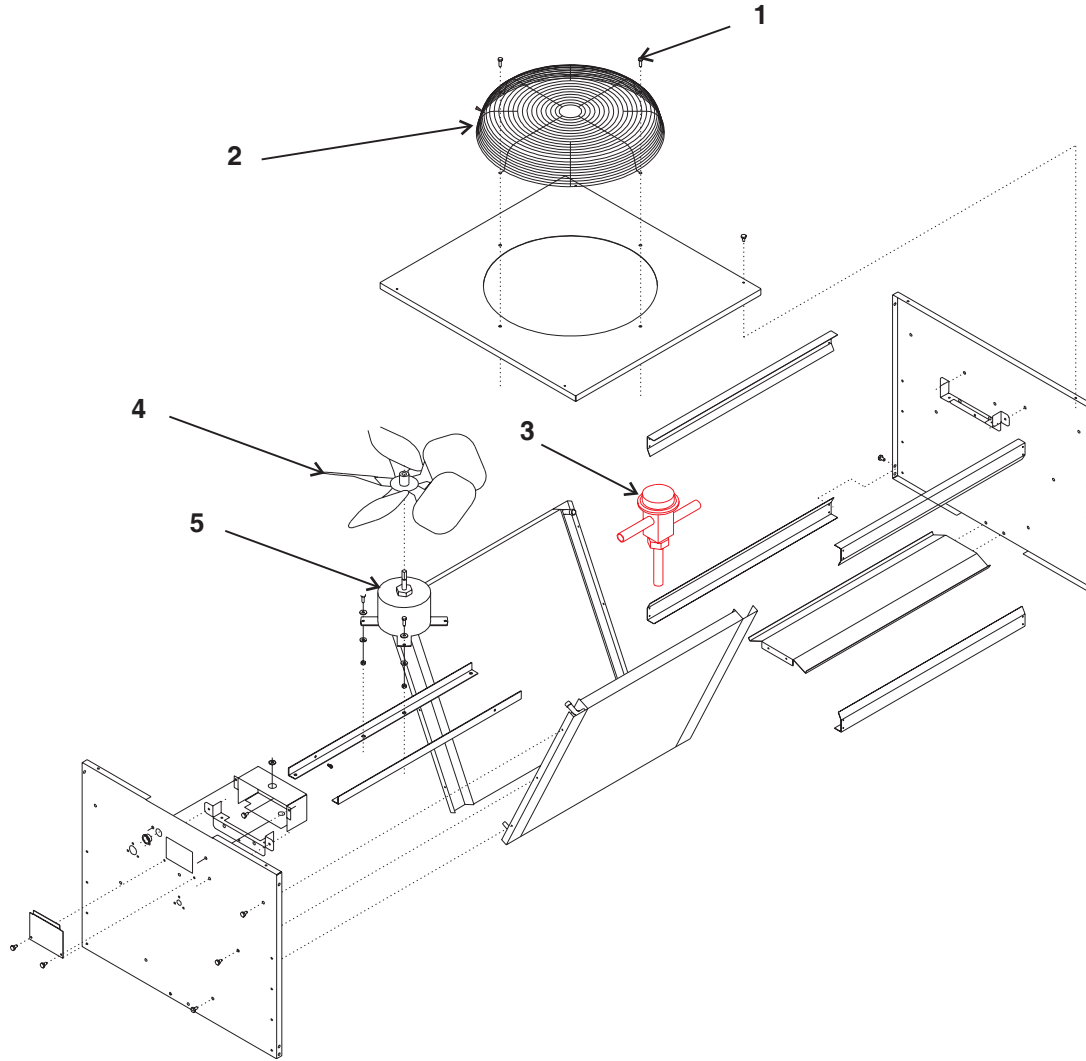

Item Number	Part Number	Description
1	03-1405-08	Screw
2	02-3575-01	Fan guard
3	16-1025-01	Headmaster
4	18-8816-01	Fan blade
5	12-2651-01	Fan motor

Not Shown:

A37169-001	Leg
A37170-001	Leg brace
03-1645-01	Screw for legs
16-0850-01	Quick connect, discharge
16-0850-03	Quick connect, liquid

CME1356R and CME1656R Service Parts

BH900 Ice Storage Bin

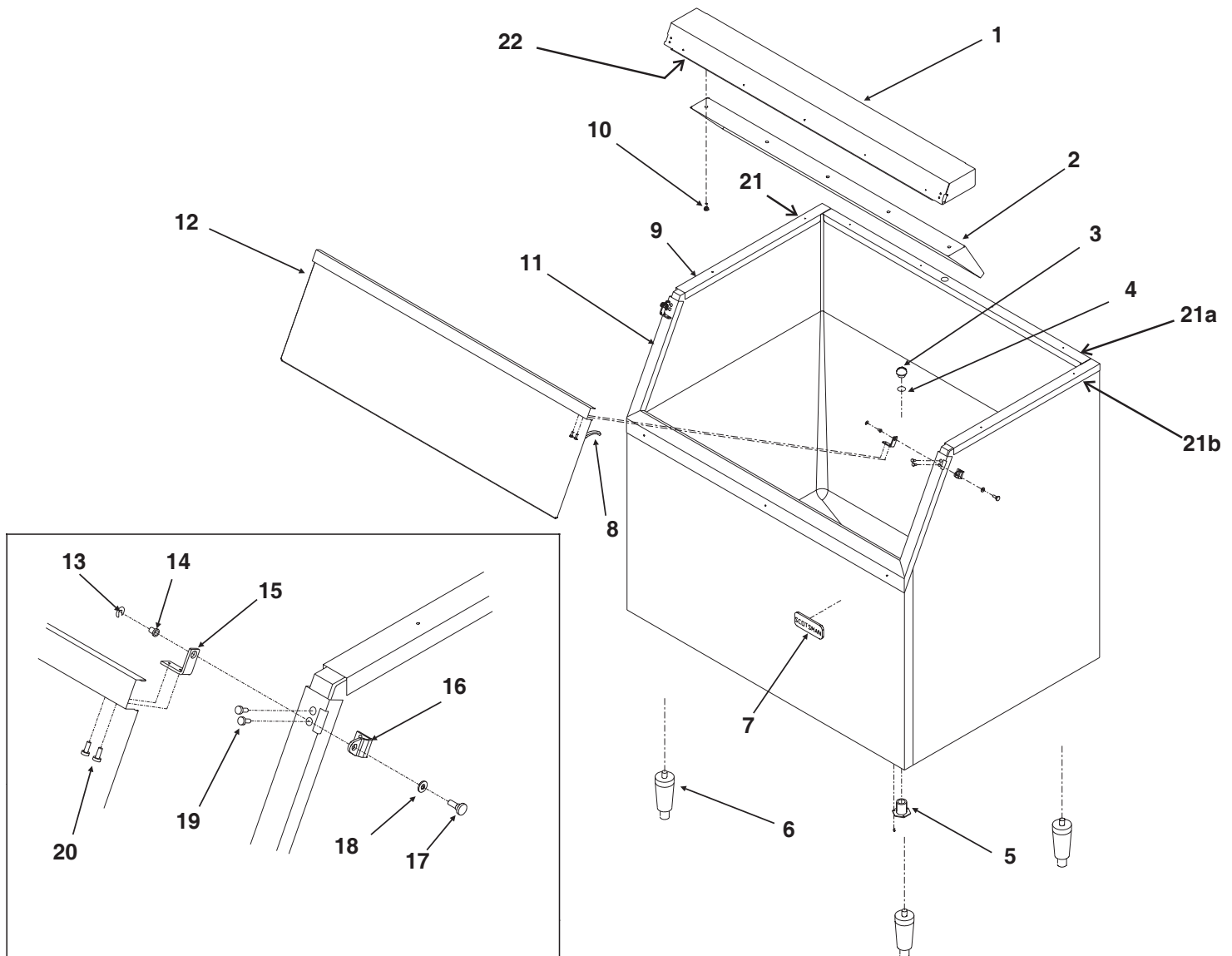

ITEM NUMBER	PARTS NUMBER	DESCRIPTION
1	A35322-020	Canopy Assembly
2	A35152-001	Ice Baffle
3	02-2809-01	Drain Top
4	13-0617-11	O-ring
5	02-3201-01	Drain casting
6	KLP2E	Leg Kit, Black
7	15-0808-03	Emblem
8	13-0595-00	Door gasket(order qty 7)
9	19-0503-04	Bin gasket (order by foot)
10	03-0727-11	Baffle screw
11	A35275-001	Door frame assy. except C
	A37641-021	C series door frame
12	A35323-020	Door with gasket - BH900
13	03-1539-09	"E" ring
14	02-2380-01	Hinge bushing
15	02-3195-01	Door hinge
16	02-3196-01	Bin hinge
17	02-2806-01	Shoulder screw
18	02-2380-02	Spacer
19	03-1403-29	Screw 10-24
20	03-1403-24	Screw 10-24
21	A35280-001	Left bin channel
21a	A35311-001	Back bin channel
21b	A35279-001	Right bin channel
22	02-3202-01	Trim guard

CME1356R and CME1656R Service Parts

BH1356 Ice Storage Bin

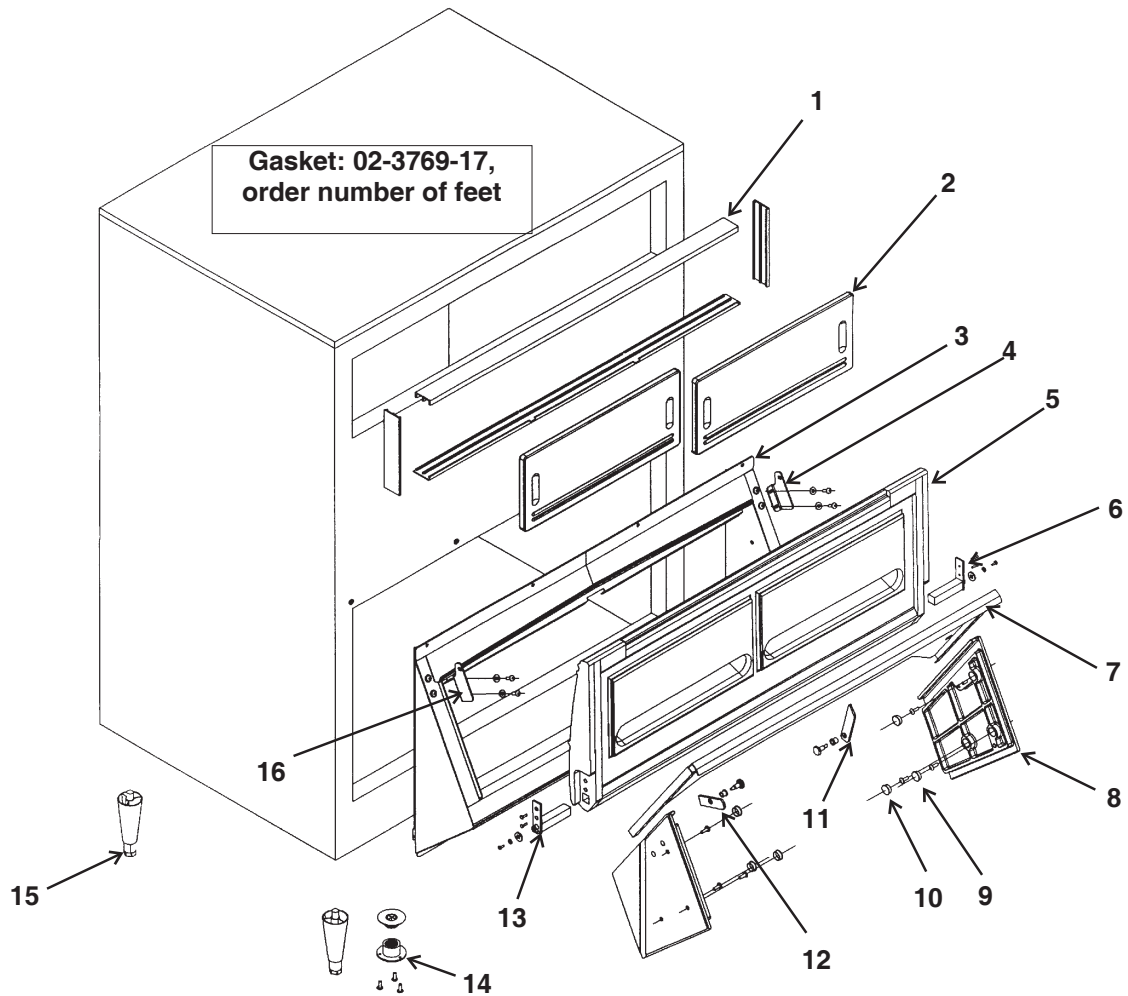

Item Number	Part Number	Description
1	02-3769-02	Track
2	02-3769-16	Window
3	02-3769-04	Lower frame assembly
4	02-3769-08	Left and right hinges
5	02-3769-05	Door with door hinges
6	02-3769-07	Right hinge
7	02-3769-09	Ice gate
8	02-3769-12	End plate guide (pair)
9	02-3769-13	Screws for end plate
10	02-3769-14	Plugs for end plate
11	02-3769-10	Catch for ice gate
12	02-3769-15	Ice gate retainer
13	02-3769-06	Left hinge
14	02-3769-01	Plastic drain
15	KLP2S	Legs

CME1356R and CME1656R Service Parts Kit Parts

Stacking Kit - KSCME6-LG-B

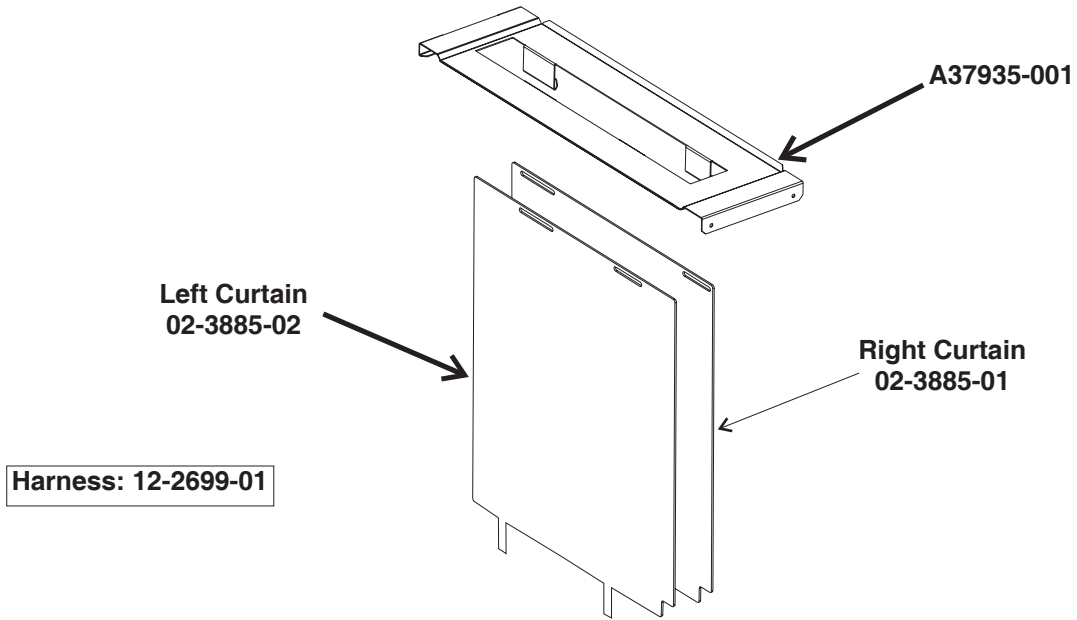

Stacking Kit - KSCME6-LG

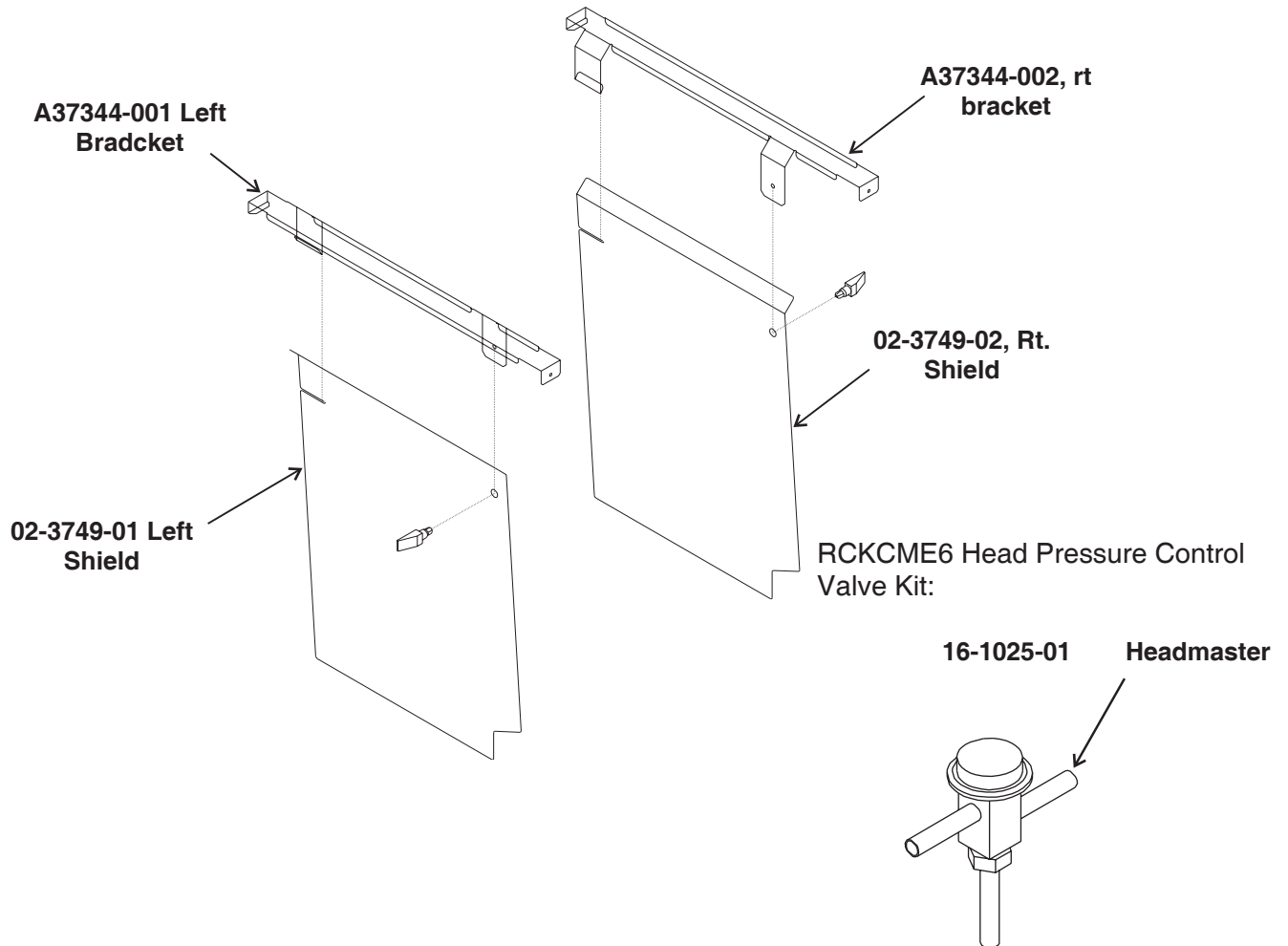

CME1356R and CME1656R Service Parts

Single Phase Wiring Diagram, D series

17-2772-01

Use Copper Conductors Only

- 1 DASHED LINES INDICATE FIELD WIRING WHICH MUST BE INSTALLED IN ACCORDANCE WITH THE NATIONAL ELECTRICAL CODE AND ALL STATE AND LOCAL CODES.
- 2 WIRE COLOR FOR 208-230/60/1 UNITS : BLACK
WIRE COLOR FOR 230/50/1 UNITS : BLUE
- 3 WIRE COLOR FOR 208-230/60/1 UNITS : BLACK W/WHITE STRIPE
WIRE COLOR FOR 230/50/1 UNITS : BROWN

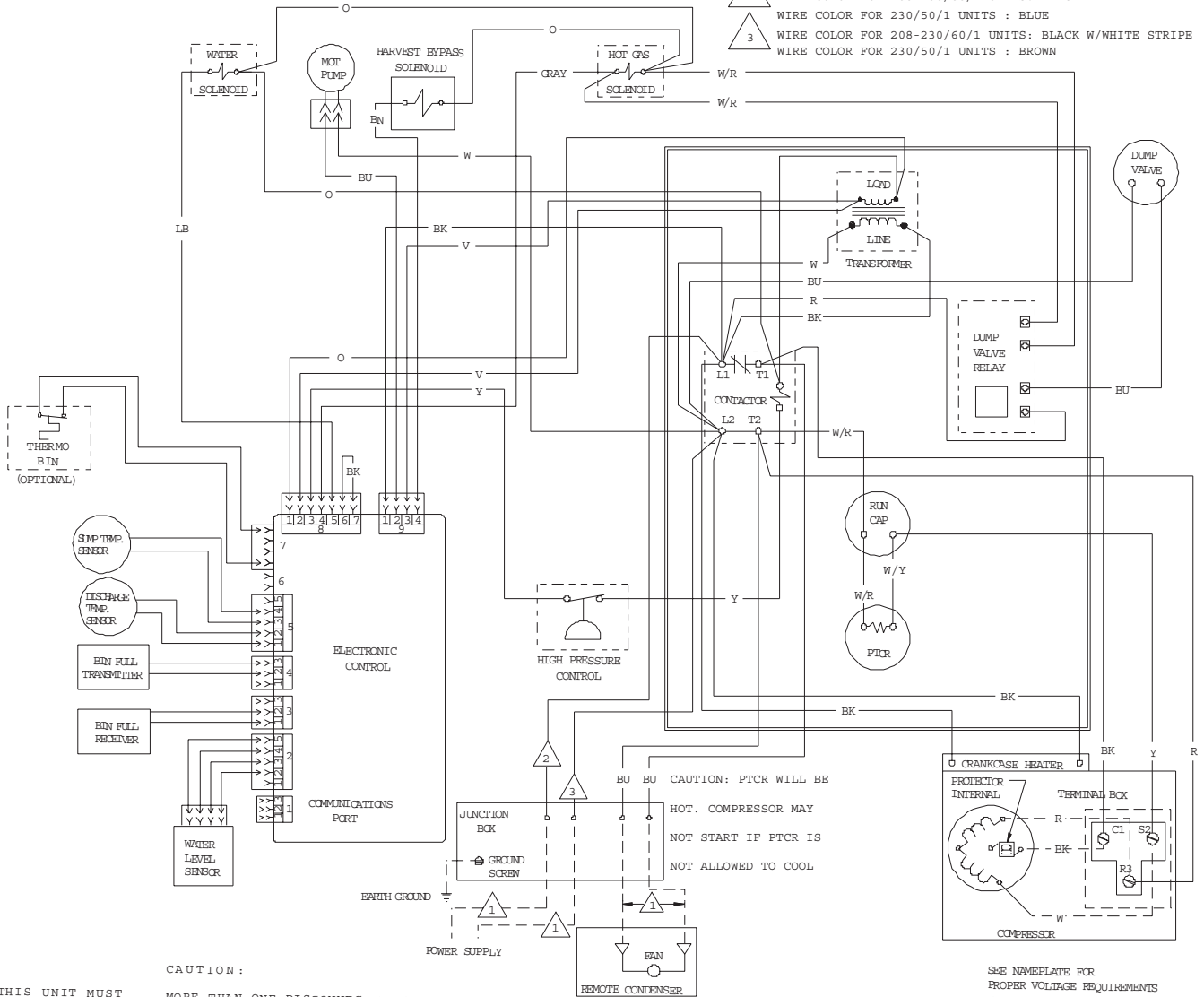

THIS UNIT MUST BE GROUNDED. MORE THAN ONE DISCONNECT MEANS MAY BE REQUIRED TO DISCONNECT ALL POWER TO THIS UNIT.

CME1356R and CME1656R Service Parts

Single Phase Schematic Diagram, D Series

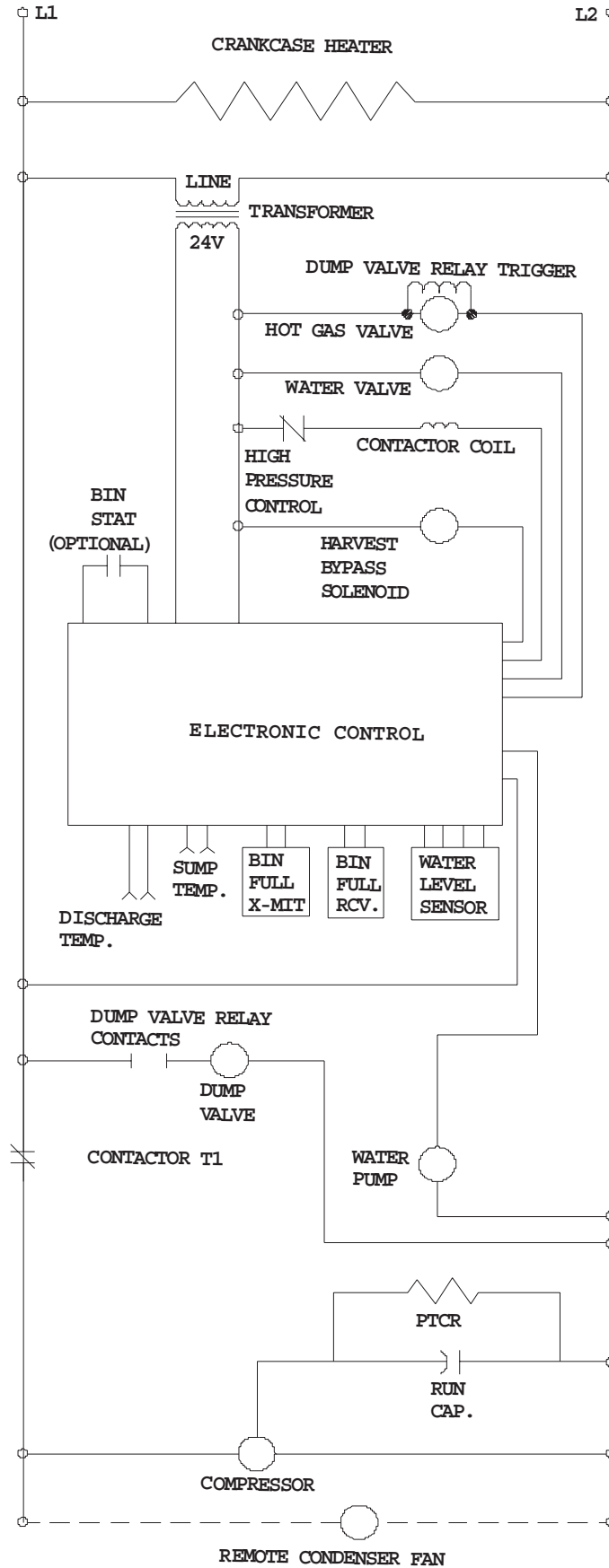

CME1356R and CME1656R Service Parts

Three Phase Wiring Diagram, D Series

17-2821-01

USE COPPER CONDUCTORS ONLY

△ DASHED LINES INDICATE FIELD WIRING WHICH MUST BE INSTALLED IN ACCORDANCE WITH THE NATIONAL ELECTRICAL CODE AND ALL STATE AND LOCAL CODES

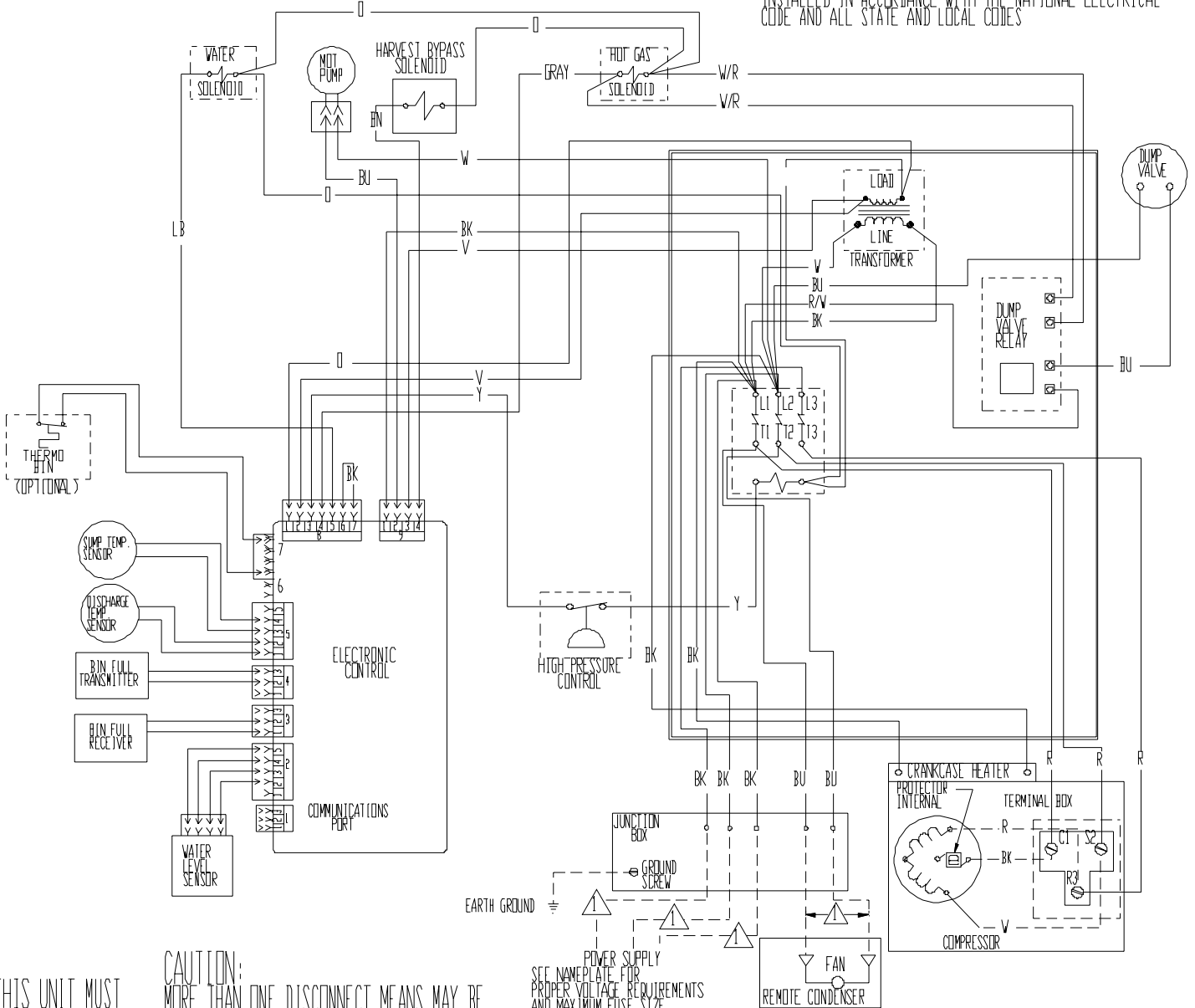

THIS UNIT MUST BE GROUNDED.

CAUTION: MORE THAN ONE DISCONNECT MEANS MAY BE REQUIRED TO DISCONNECT ALL POWER TO THIS UNIT.

SEE NAMEPLATE FOR PROPER VOLTAGE REQUIREMENTS AND MAXIMUM FUSE SIZE

CME1356R and CME1656R Service Parts

50 Hz Wiring Diagram, D Series

17-2777-01

USE COPPER CONDUCTORS ONLY

1 DASHED LINES INDICATE FIELD WIRING WHICH MUST BE INSTALLED IN ACCORDANCE WITH THE NATIONAL ELECTRICAL CODE AND ALL STATE AND LOCAL CODES.

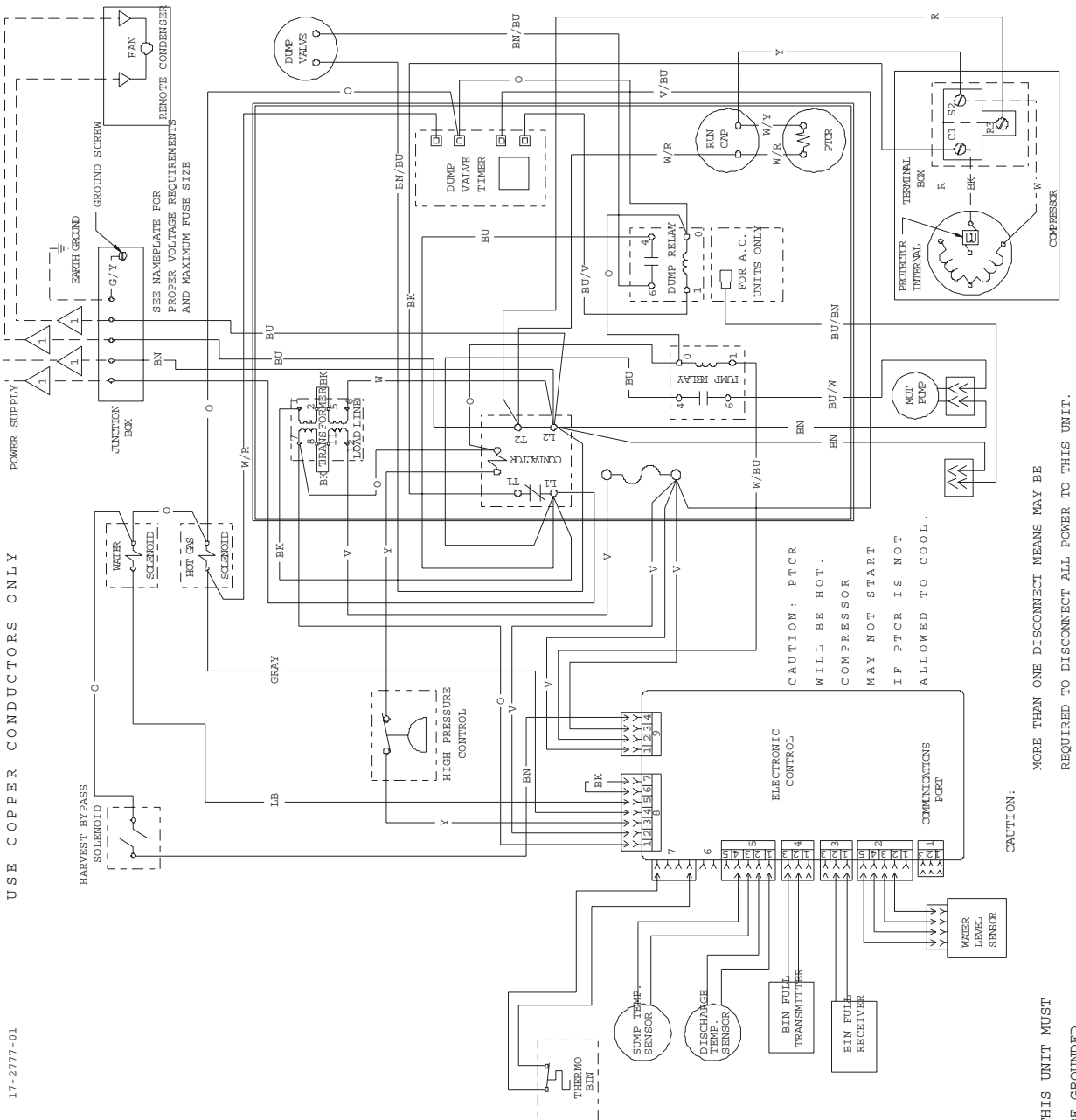

CME1356R and CME1656R Service Parts

Single Phase Wiring Diagram

17-2504-01

USE COPPER CONDUCTORS ONLY

⚠ DASHED LINES INDICATE FIELD WIRING WHICH MUST BE INSTALLED IN ACCORDANCE WITH THE NATIONAL ELECTRICAL CODE AND ALL STATE AND LOCAL CODES.

⚠ WIRE COLOR FOR 208-230/60/1 UNITS: BLACK
WIRE COLOR FOR 230/50/1 UNITS: BROWN

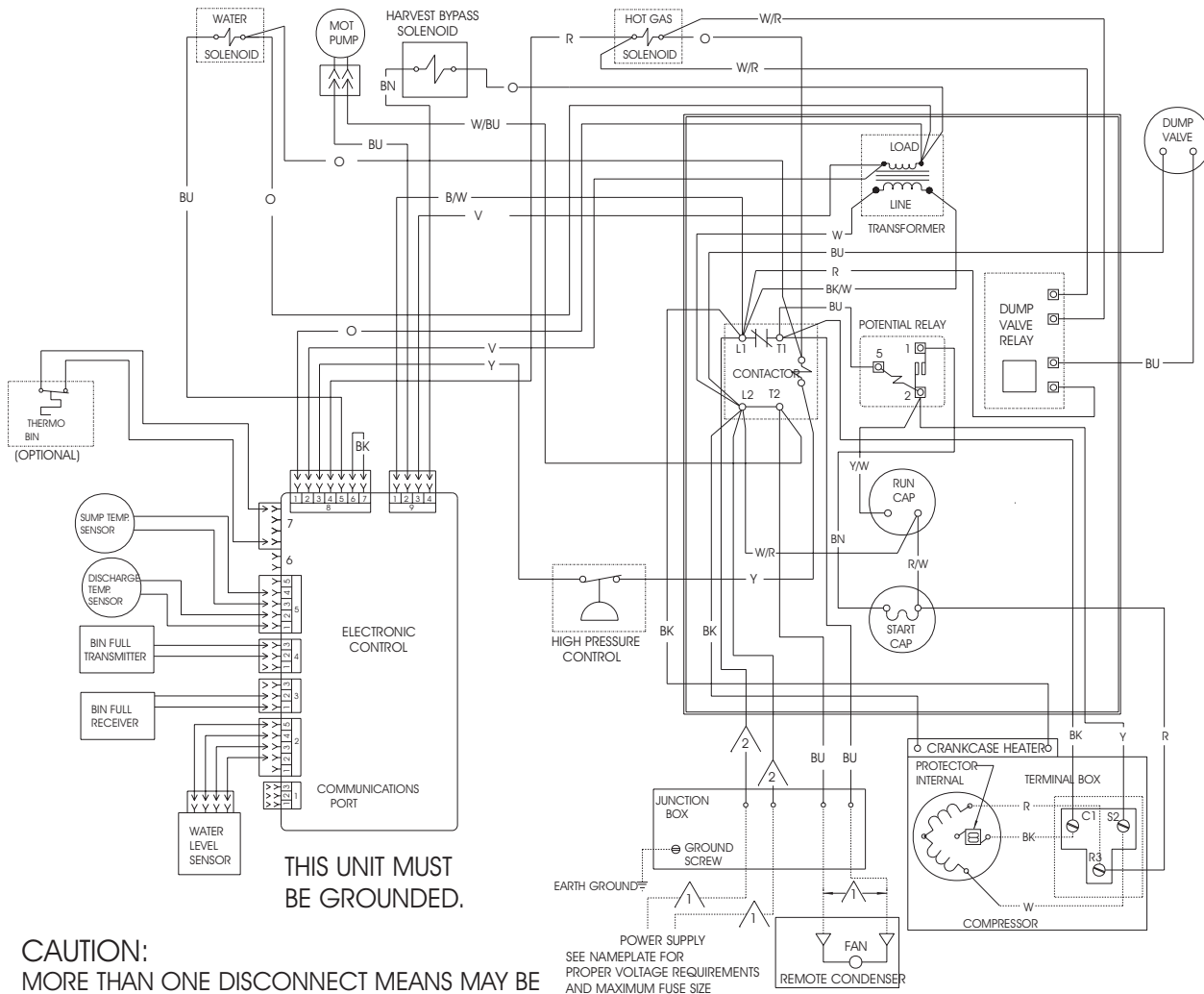

THIS UNIT MUST BE GROUNDED.

CAUTION:
MORE THAN ONE DISCONNECT MEANS MAY BE REQUIRED TO DISCONNECT ALL POWER TO THIS UNIT.

CME1356R and CME1656R Service Parts

Single Phase Schematic Diagram

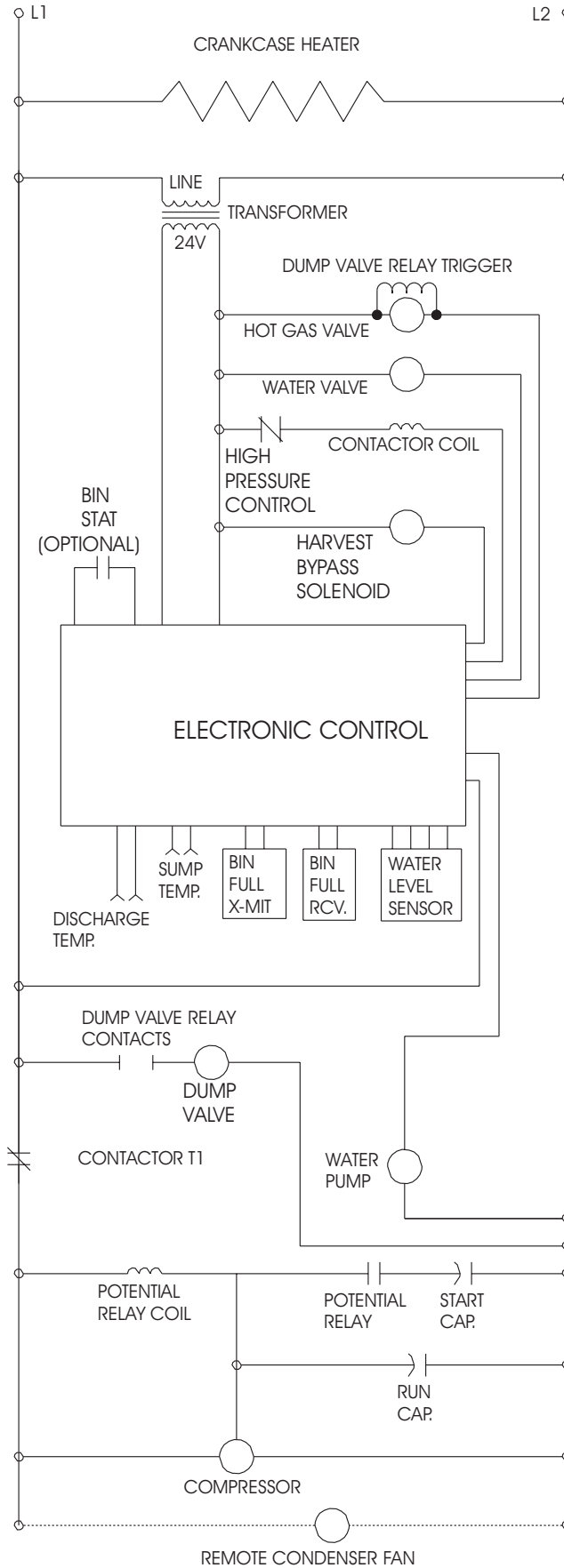

CME1356R and CME1656R Service Parts

Three Phase Wiring Diagram

17-2513-03

USE COPPER CONDUCTORS ONLY

△ DASHED LINES INDICATE FIELD WIRING WHICH MUST BE INSTALLED IN ACCORDANCE WITH THE NATIONAL ELECTRICAL CODE AND ALL STATE AND LOCAL CODES.

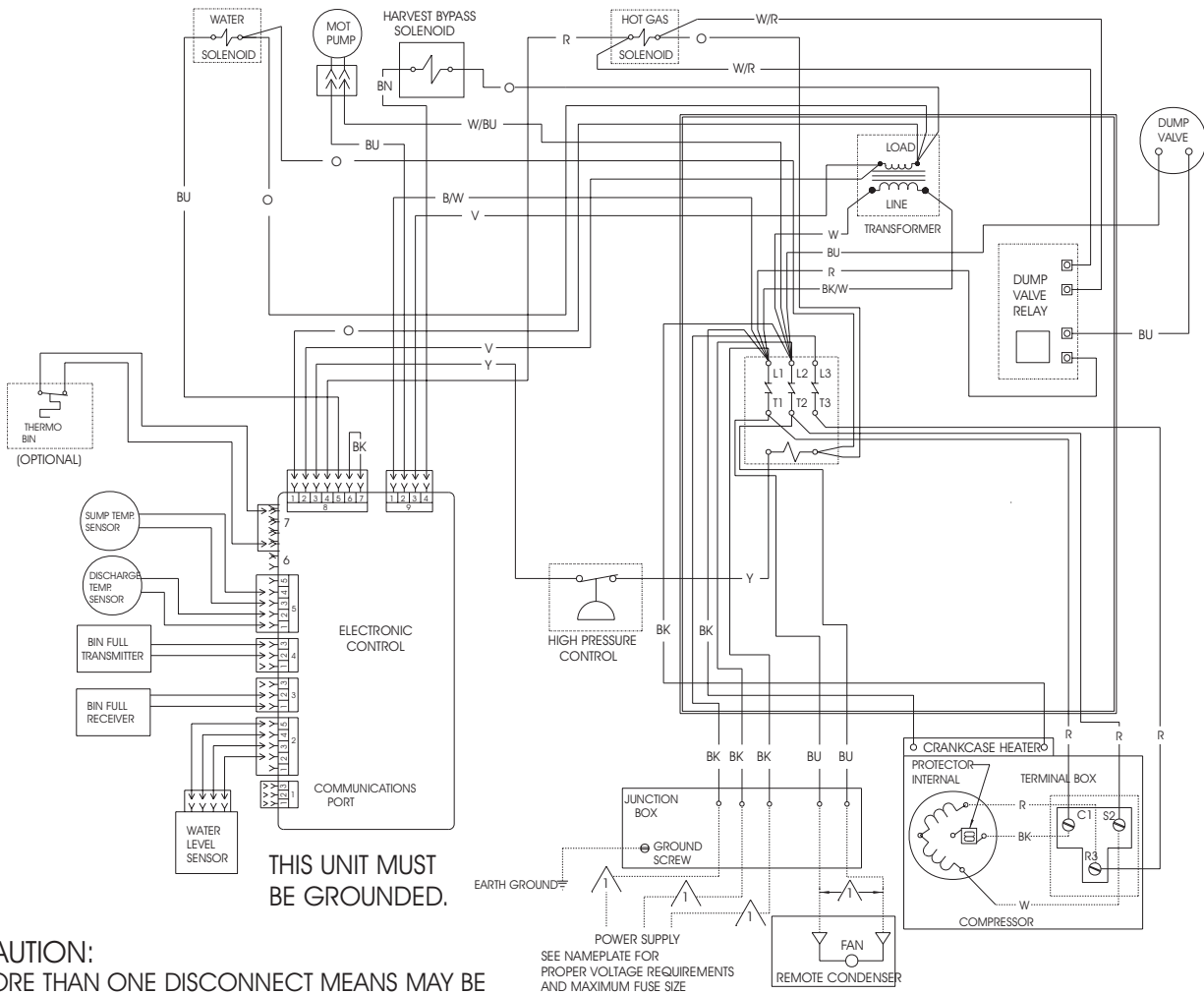

CME1356R and CME1656R Service Parts

Three Phase Schematic Diagram

