

# **Star Max<sup>®</sup>**

## **ELECTRIC GRIDDLES**

MODEL  
536TGD-230V  
CHROME-MAX MODEL  
536CHSD-230V

### **Installation and Operation Instructions**

2M-Z9837 Rev. A 8/7/06



536TGD



## SAFETY SYMBOL



These symbols are intended to alert the user to the presence of important operating and maintenance instructions in the manual accompanying the appliance.

---

## RETAIN THIS MANUAL FOR FUTURE REFERENCE NOTICE

Using any part other than genuine Star factory supplied parts relieves the manufacturer of all liability.

Star reserves the right to change specifications and product design without notice. Such revisions do not entitle the buyer to corresponding changes, improvements, additions or replacements for previously purchased equipment.

Due to periodic changes in designs, methods, procedures, policies and regulations, the specifications contained in this sheet are subject to change without notice. While Star Manufacturing exercises good faith efforts to provide information that is accurate, we are not responsible for errors or omissions in information provided or conclusions reached as a result of using the specifications. By using the information provided, the user assumes all risks in connection with such use.

## MAINTENANCE AND REPAIRS

Contact your local dealer for service or required maintenance. Please record the model number, serial number, voltage and purchase date in the area below and have it ready when you call to ensure a faster service.

Model No. \_\_\_\_\_

Serial No. \_\_\_\_\_

Voltage \_\_\_\_\_

Purchase Date \_\_\_\_\_



## CAUTION

This equipment is designed and sold for commercial use only by personnel trained and experienced in its operation and is not sold for consumer use in and around the home nor for use directly by the general public in food service locations.

Before using your new equipment, read and understand all the instructions & labels associated with the unit prior to putting it into operation. Make sure all people associated with its use understand the units operation & safety before they use the unit.

All shipping containers should be checked for freight damage both visible and concealed. This unit has been tested and carefully packaged to insure delivery of your unit in perfect condition. If equipment is received in damaged condition, either apparent or concealed, a claim must be made with the delivering carrier.

Concealed damage or loss - if damage or loss is not apparent until after equipment is unpacked, a request for inspection of concealed damage must be made with carrier within 15 days. Be certain to retain all contents plus external and internal packaging materials for inspection. The carrier will make an inspection and will supply necessary claim forms.

## INSTALLATION

The griddles are equipped for the voltage indicated on the nameplate mounted under the bullnose on the front panel. They will operate on alternating current (AC) only.



## WARNING

**DO NOT CONNECT TO DIRECT CURRENT (DC).**

**DO NOT CONNECT TO AN ELECTRICAL SYSTEM OPERATING AT MORE THAN 240 VOLTS TO GROUND.**

The installation of the electric griddle should conform to the:

**NATIONAL ELECTRIC CODE AND ALL LOCAL ELECTRIC CODES AND ORDINANCES AND THE LOCAL ELECTRIC COMPANY RULES AND REGULATIONS**

For your protection we recommend that a qualified electrician install this griddle. He should be familiar with electrical installations and all electric codes. Proper connections and power supply are essential for efficient performance. The external wiring should be in conduit or an approved type of flexible cable suitable for operation at the temperature indicated on the wiring diagram, and of a proper size to carry the load. The supply circuit should be properly fused and equipped with a means of disconnecting, as required by local electrical code. **THE BODY OF THE GRIDDLE SHOULD BE GROUNDED (DO NOT GROUND TO A GAS SUPPLY LINE).**

## GENERAL OPERATING PROCEDURES

The Chrome-Max and Star-Max series electric griddles may be wired for operation in the field for 3-phase power supplies by making line connections at the junction box(es) located at the rear of the unit.

### CONNECTING POWER SUPPLY

Detach cover on junction box at rear of unit. A terminal block is provided for supply connection in the junction box.

### LOCATING AND LEVELING THE UNIT

Do not install the unit closer than 1-inch from a side wall and/or closer than 1-inch from a rear wall. Level unit by adjusting the (4) feet which have an adjustment of 1-3/4" (43.75mm) for accurate leveling and perfect line-up with other Star-Max series units.

## **SEASONING THE GRIDDLE HEATING SURFACE (NON CHROMIUM SURFACE)**

Clean the griddle surface thoroughly. After the griddle has been thoroughly cleaned, it should be seasoned to prevent food from sticking. Before using and after each thorough scouring, season the griddle heating surface in the following manner.

1. Turn temperature control dials to 350°F (177°C).
2. Using a clean cloth, not a spatula, spread a thin film of cooking oil over the griddle cooking surface. This film should remain on the hot griddle surface for half an hour.
3. Remove the excess oil and wipe clean.
4. Apply another film of cooking oil over the hot cooking area for another half hour and again remove excess oil and wipe clean. The griddle surface should now be ready for use.

Even with careful seasoning, food may, to some extent, stick to the griddle cooking surface until the griddle plate is broken in.

## **TEMPERATURE CONTROL**

The temperature controls are combination "ON/OFF" switches and thermostats. Turning the dial knob automatically maintains the selected heat range.

The Star-Max/Chrome-Max electric griddle line has one thermostat for every 12" (30cm) section of griddle that operates independently of one another. Each thermostat controls the section of the griddle above it and may be set at different temperatures as desired.

## **COOKING**

Set the thermostat dial knob at the temperature desired. After a short pre-heating period, the thermostat will automatically maintain the selected temperature.

## **IDLING**

During idle periods, to save on operating costs, lower the temperature setting of the thermostat to about 250°F (121°C). It is not necessary to maintain cooking temperature during idle periods, as the griddle can quickly be reheated to the desired temperature.

## **SIGNAL LIGHTS**

Each thermostat has its own signal light which indicates when the unit's control knob is not in the off position.

## **GRIDDLE CARE (NON-CHROMIUM SURFACES)**

It takes very little time and effort to keep the griddle attractive and performing at top efficiency. If grease is permitted to accumulate, it will form a gummy cake and then carbonize into a hard substance which is extremely difficult to remove. To prevent this condition, the following suggestions for cleanliness should be followed:

1. After each use, scrape the griddle with a scraper or flexible spatula to remove excess grease and food. A waste drawer is provided for the scrapings. If there is an accumulation of burned on grease and food, the griddle should be thoroughly scoured and reseasoned. Use pumice or griddle stone while the griddle is warm. Do not use steel wool because of the danger of steel slivers getting into the food.
2. Daily, use a clean cloth and a good non-abrasive cleaner to clean the stainless steel body of the griddle. Wipe the polished front with a soft cloth.
3. At least once a day, remove the waste drawer and wash in the same way as an ordinary cooking utensil. The drawers are removed by pulling forward until they are released from their track.

## GRIDDLE CARE (CHROMIUM SURFACES)

It takes very little time and effort to keep this Industrial Chromium griddle surface sparkling clean and performing at top efficiency. **DO NOT** allow grease to accumulate as it will carbonize and become difficult to remove. To prevent this condition the following cleaning suggestions should be followed:

1. Remove excess grease and food regularly with a 4" (100mm) wide Razor Sharp type scraper and wipe surface with a damp cloth if desired.
2. Following the scraping, for end of the day cleaning, a damp cloth and a non-silicated, non-abrasive, non-chlorinated cleaner such as Bon-Ami may be used to wipe surface clean, followed by wiping with a clean wet cloth.
3. Follow steps 2 and 3 from Griddle Care (Non-Chromium Surfaces) above.



### CAUTION

1. **Never** use pumice, griddle stones, or abrasives on a chromium surface.
2. **Never** strike a chromium griddle surface with a sharp instrument or spatula edge.
3. **Never** use steel wool.
4. **Never** use commercial liquid grill cleaner on the griddle surface.
5. **Abusing** surface voids the warranty.

## MAINTENANCE AND REPAIRS

Contact the factory, a service representative, or a local service company for service or required maintenance.

## CHROME-MAX GRIDDLE SURFACE LIMITED WARRANTY EXCLUSIONS

Your Chrome-Max griddle has been designed to give you many years of cooking reliability and requires minimum maintenance to keep the chrome surface in its original condition. All Chrome-Max griddle surfaces are warranted for a period of 5 years against manufacturing defects to the original owner from the date of installation. This limited warranty is void if it is determined by Star Manufacturing International Incorporated or one of its authorized representatives that the chrome surface has been misused or abused or subjected to the following situations:

1. Improperly installed.
2. Incorrect voltage applied to electric Chrome-Max units allowing the surface to overheat and discolor.
3. The misuse of any instrument or tool which scratches or makes indentations in the surface which could cause the surface to peel, flake, or chip off.
4. The use of any chemical or abrasive cleaning solution, griddle brick, stone, screen or other cleaning products which could damage and affect the performance of the chrome surface.
5. The neglect of daily routine maintenance to the chromium surface.

## INTERNATIONAL ONE (1) YEAR EQUIPMENT WARRANTY

All workmanship and materials in “STAR” products are warranted for a period of one year from the date shipped from the factory or one year from the date shown on the proof of purchase of the end-user when purchased through an authorized “STAR” dealer/distributor in a commercial foodservice location.

“STAR’s” obligation under this warranty is limited to the replacement of the defective part(s) only without charge. This warranty is void if damage occurs from improper installation, misuse or abuse, disassembly or tampering of unit for any purpose other than repair by a qualified service agent, wrong voltage, incorrect or fluctuating voltage conditions, wrong gas, improper gas or gas conditions, operated contrary to the installation and operating instructions, operated in an application for which the unit is not suited, or if the unit is not maintained and/or cleaned in a suitable manner.

Any expense in connection with installation, or any cost of making adjustments on a unit to conform to electric or gas service at the point of installation, are not covered by this warranty.

- \* The warranty period for the JetStar series six (6) ounce popcorn machines is two (2) years.
- \* The warranty period for the Chrome-Max Griddles is five (5) years on the griddle surface. See detailed warranty provided with unit.
- \* The warranty period for Teflon/Dura-Tec coatings is one year under normal use and reasonable care. This warranty does not apply if damage occurs to Teflon/Dura-Tec coatings from improper cleaning, maintenance, use of metallic utensils, or abrasive cleaners. This warranty does not apply to the “non-stick” properties of such materials.
- \* This warranty is not valid on Conveyor Ovens unless a “start-up/check-out has been performed by a Factory Authorized Technician.

In order to make a claim under this warranty; a warranty report must be filed with Star Manufacturing International Inc. in St. Louis, Missouri, U.S.A. by the dealer/distributor through which product was purchased. All details, including serial number and model number of the defective unit, must be included. Failure to file a claim within a 120 Day time period may result in the claim being refused.

“STAR” may forego the necessity of returning the part for inspection dependent upon the expense involved. However, “STAR” requires defective parts to be held in the claimant’s possession for a period of ninety (90) days for possible inspection by a “STAR” representative or designated inspector .

The foregoing warranty is lieu of any and all other warranties, expressed or implied, and constitutes the entire warranty.

## PARTS WARRANTY

Parts that are sold for out-of-warranty repair are warranted for a period of ninety days. The part only is warranted; no labor. 

## SERVICES NOT COVERED BY WARRANTY

1. Labor
2. Mileage and/or travel time
3. Installation and/or adjustment of equipment
4. Operation contrary to the installation and operating instructions
5. Cleaning of equipment
6. Seasoning of griddle plates
7. Voltage conversions/adjustments
8. Gas conversions
9. Pilot light conversion/adjustments
10. Thermostat calibration/adjustments
11. Resetting of circuit breakers or safety controls
12. Replacement of bulbs/lamps
13. Replacement of fuses
14. Damages due to improper installation
15. Damages from abuse or misuse
16. Damage created by acts of God, Acts of War, or Civil Disturbance



DR. TH CK. DATE 6-9-06

TOLERANCES UNLESS OTHERWISE NOTED  
FRACTIONS ±1/64 DECIMALS ±.005 ANGLES ±1°

MATERIAL

~

FINISH

~

THIS DRAWING CONTAINS INFORMATION CONFIDENTIAL TO STAR MFG. INT'L. INC.  
NO REPRODUCTION OR DISCLOSURE OF ITS CONTENTS IS PERMITTED.

MODEL NO.

536TGD 220/230V

PART NO.

SK2204

TITLE  
WIRING DIAGRAM 3 PHASE 5 WIRE

REVISIONS LTR DATE DESCRIPTION OF CHANGE DR

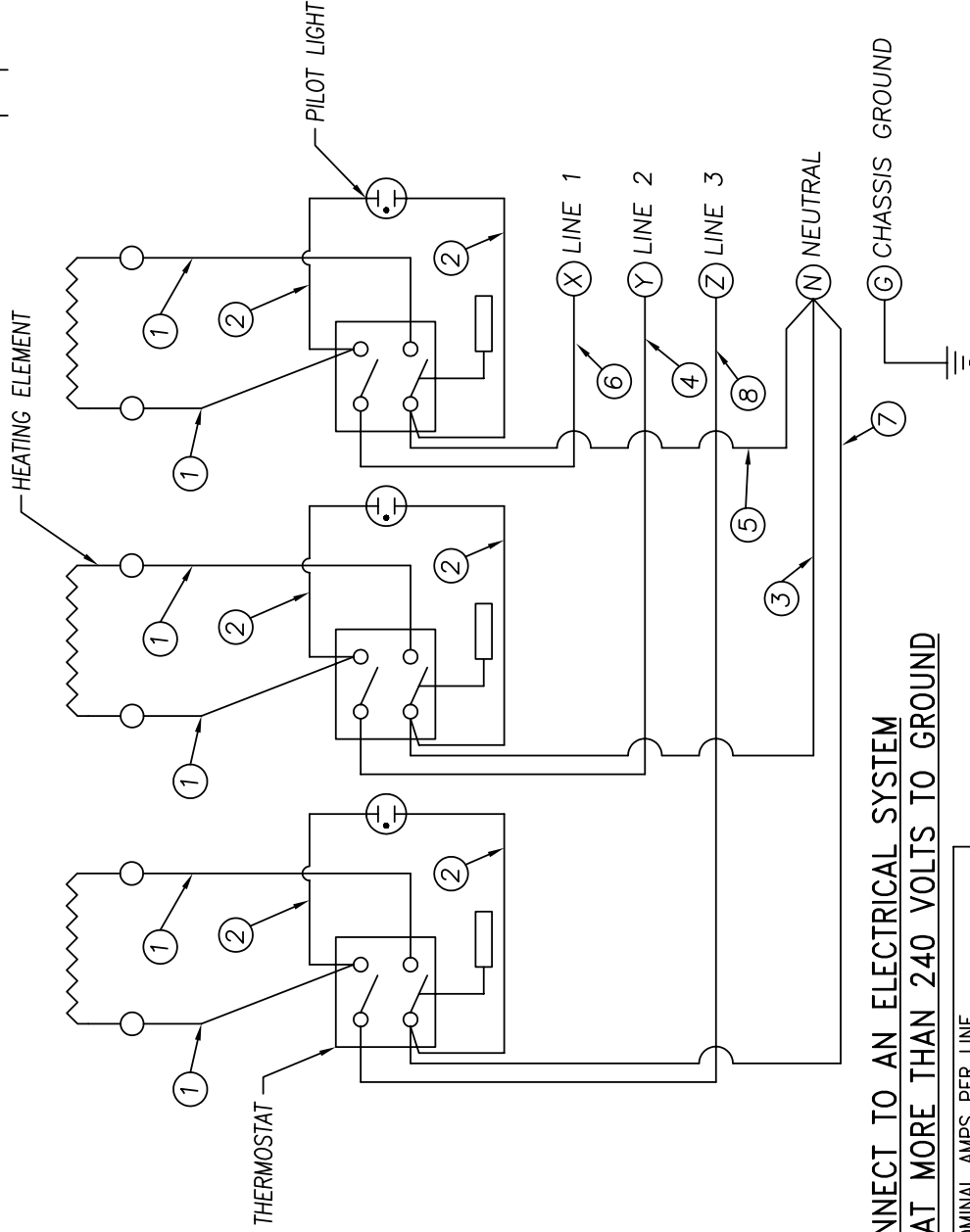

**DO NOT CONNECT TO AN ELECTRICAL SYSTEM OPERATING AT MORE THAN 240 VOLTS TO GROUND**

NOMINAL AMPS PER LINE			
220/380V Y	230/400V Y		
10083 WATTS			
X	Y	Z	N
15.3	15.3	15.3	16

FOR SUPPLY CONNECTIONS USE  
COPPER WIRE ONLY, SUITABLE  
FOR AT LEAST 90°C (194°F). #10  
AWG OR LARGER.

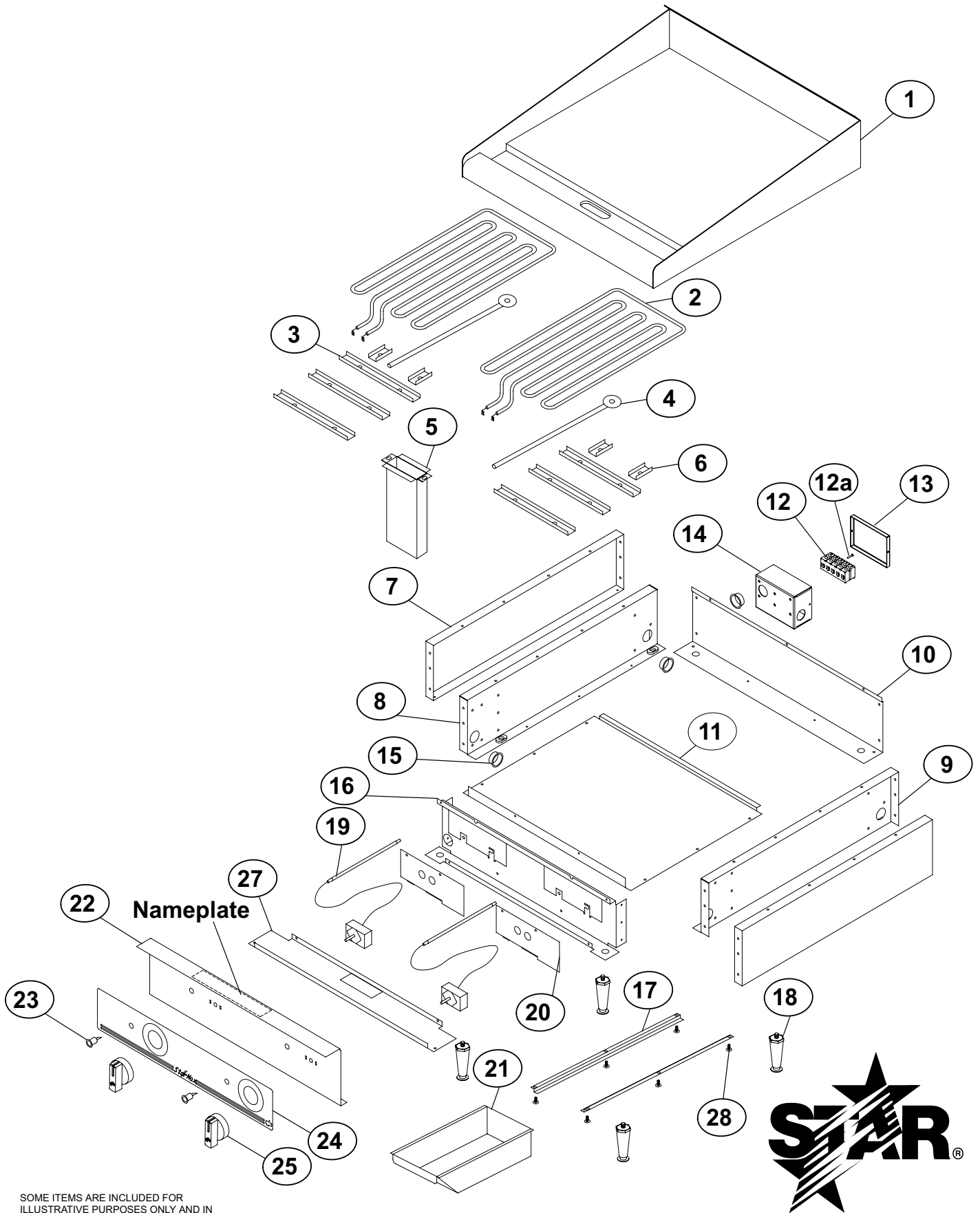

SOME ITEMS ARE INCLUDED FOR  
ILLUSTRATIVE PURPOSES ONLY AND IN  
CERTAIN INSTANCES MAY NOT BE AVAILABLE

**MODEL - 524TGD, 524CHSD-230V (TYPICAL)**

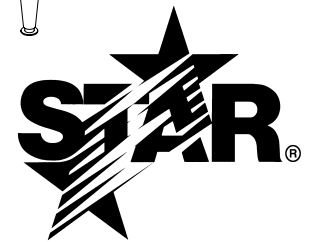

**STAR MANUFACTURING INTERNATIONAL, INC.**

SK2210

REV. A

8/7/06



# PARTS LIST

August 7, 2006, Rev. A

MODEL 536TGD / 536CHSD-230V Star-Max/Chrome-Max Electric Griddles

Key Number	Part Number	Number Per Unit	Description and Model Designation
1	G3-536311	1	GRIDDLE PLATE STUDED 536CHSD
1	G3-536310	1	GRIDDLE PLATE STUDED 536TGD
2	2N-Z5948	3	HEATING ELEMENT 536
3	G3-Z5972	9	ELEMENT CLAMP LONG 536
4	G3-GD0036	3	TUBE-WASHER ASSEMBLY 536
5	G3-624304	1	CHUTE ASSEMBLY 536
6	G3-Z5973	6	ELEMENT CLAMP SHORT 536
7	G3-Z5945	2	SIDE PANEL ALL
8	G3-624302	1	SIDE LINER ASSEMBLY LEFT ALL
9	G3-624303	1	SIDE LINER ASSEMBLY RIGHT ALL
10	G3-Z9848	1	REAR PANEL 536
11	G3-Z5995	1	BOTTOM PANEL 536
12	2F-Z9565	1	TERMINAL BLOCK 536
12a	2C-H1559	2	SCREWS 8-32X1.25 ST RH 536
13	H1-Z9843	1	BOX COVER 536
14	H1-Z9842	1	ELECTRICAL BOX 536
15	2K-Z6183	3	BUSHING 536
16	G3-Z5925	1	CENTER WALL 536
17	G3-Z6036	2	DRAWER SLIDE ALL
18	2A-Z5942	4	FOOT ALL
19	2T-Z5958	3	THERMOSTAT ALL
20	G3-Z5947	3	COVER 536
21	G3-Y7046	1	GREASE DRAWER ALL
22	G3-Z5921	1	FRONT PANEL 536
23	2J-Y6690	3	PILOT LIGHT 536
24	2M-Z5920	1	GRAPHIC PANEL 536TGD, 536CHSD
25	2R-Z8892	3	KNOB 536
25	2R-Z8893	1	KNOB 536TGDS
27	G3-Z5999	1	FRONT BOTTOM PANEL 536
28	2C-8823	Various	SCREW #8 x 3/8 ALL
N/A	2E-Z5971	1	WIRE SET 536
N/A	2C-Z8547	AR	BOLT, KNOB STOP ALL
N/A	G3-536300	1	GROUND WIRE ASSY 536

**IMPORTANT: WHEN ORDERING, SPECIFY VOLTAGE OR TYPE GAS DESIRED  
INCLUDE MODEL AND SERIAL NUMBER**

PAGE 1  
OF 1

Some items are included for illustrative purposes only and in certain instances may not be available.







**STAR MANUFACTURING**

10 Sunnen Drive, St. Louis, MO 63143 U.S.A.

(800) 807-9054 (314) 781-2777

Parts & Service (800) 807-9054

[www.star-mfg.com](http://www.star-mfg.com)