

STAR[®] PASTRY DISPLAY CABINET

MODEL
15PDC-A

PRETZEL DISPLAY

MODEL
16PD-A

Installation and Operation Instructions

2M-Y4633 Rev. K 1/13/2010



15PDC-A



SAFETY SYMBOL



These symbols are intended to alert the user to the presence of important operating and maintenance instructions in the manual accompanying the appliance.

RETAIN THIS MANUAL FOR FUTURE REFERENCE NOTICE

Using any part other than genuine Star factory supplied parts relieves the manufacturer of all liability.

Star reserves the right to change specifications and product design without notice. Such revisions do not entitle the buyer to corresponding changes, improvements, additions or replacements for previously purchased equipment.

Due to periodic changes in designs, methods, procedures, policies and regulations, the specifications contained in this sheet are subject to change without notice. While Star International Holdings Inc., Company exercises good faith efforts to provide information that is accurate, we are not responsible for errors or omissions in information provided or conclusions reached as a result of using the specifications. By using the information provided, the user assumes all risks in connection with such use.

MAINTENANCE AND REPAIRS

Contact your local authorized service agent for service or required maintenance.

Please record the model number, serial number, voltage and purchase date in the area below and have it ready when you call to ensure a faster service.

Model No. _____

Serial No. _____

Voltage _____

Purchase Date _____

Authorized Service Agent Listing

Reference the listing provided with the unit

OR

for an updated listing go to:

Website: www.star-mfg.com
E-mail Service@star-mfg.com

Service Help Desk

Business Hours: 8:00 am to 4:30 p.m. Central Standard Time

Telephone: (314) 678-6303

Fax: (314) 781-2714

E-mail Parts@star-mfg.com
Service@star-mfg.com
Warranty@star-mfg.com

Website: www.star-mfg.com

Mailing Address: Star International Holdings Inc., Company
10 Sunnen Drive
St. Louis, MO 63143
U.S.A



CAUTION

This equipment is designed and sold for commercial use only by personnel trained and experienced in its operation and is not sold for consumer use in and around the home nor for use directly by the general public in food service locations. For equipment to be used by the general public, please contact Star Manufacturing, Technical Services.

All shipping containers should be checked for freight damage both visible and concealed. This unit has been tested and carefully packaged to insure delivery of your unit in perfect condition. If equipment is received in damaged condition, either apparent or concealed, a claim must be made with the delivering carrier.

Concealed damage or loss - if damage or loss is not apparent until after equipment is unpacked, a request for inspection of concealed damage must be made with carrier within 15 days. Be certain to retain all contents plus external and internal packaging materials for inspection. The carrier will make an inspection and will supply necessary claim forms.

NOTE: This page contains two models with different design specifications.

GENERAL OPERATING INSTRUCTIONS

15PDC-A

This model requires no electrical hookup.

This pastry display will help impulse sales when placed on either a front or back counter.

ASSEMBLY

Place shelves on rack as shown in this illustration, and place rack into cabinet.

16PD-A

VOLTAGE

This display is equipped for operation on 120V, 60 Hertz AC single phase service only.

Do not connect to any other type of current or the machine will be seriously damaged.

The stainless steel pretzel holder will accommodate up to 36 pretzels and keep them warm with the heat from the two 85 watt reflector flood lamps.

Turn ON the lead-in cord switch to activate both the lamps and the rotation of the pretzel holder.

ASSEMBLY

The doorknob must be attached as shown, with a Phillips screwdriver.

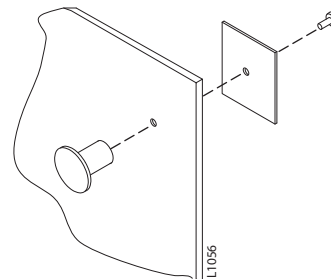
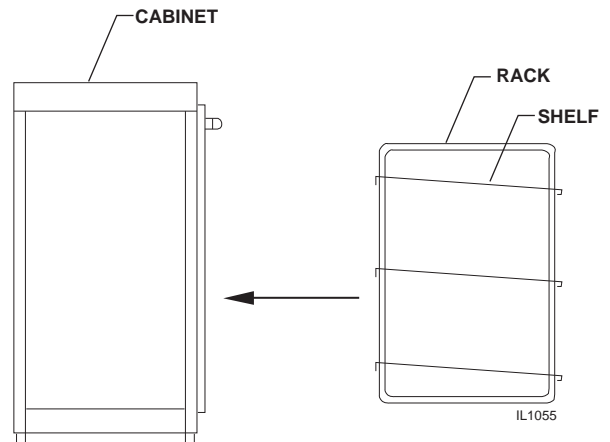

CLEANING

For retaining the high luster on the stainless steel, use a non-abrasive standard stainless steel cleaner. Use a damp cloth and warm, mild soap solution to clean the glass and plastic surfaces. The rack and shelf assembly on the 15PDC-A and the holder on the 16PD-A are easily removed and may also be cleaned using a damp cloth and a warm, mild soap solution.

MAINTENANCE AND REPAIRS

Contact the factory, a service representative, or a local service company for service or required maintenance.

THOROUGHLY INSPECT YOUR UNIT ON ARRIVAL

This unit has been tested for proper operation before leaving our plant to insure delivery of your unit in perfect condition. However, there are instances in which the unit may be damaged in transit. In the event you discover any type of damage to your product upon receipt, you must immediately contact the transportation company who delivered the item to you and initiate your claim with same. If this procedure is not followed, it may affect the warranty status of the unit.

LIMITED EQUIPMENT WARRANTY

All workmanship and material in Star products have a one (1) year limited warranty on parts & labor in the United States and Canada. Such warranty is limited to the original purchaser only and shall be effective from the date the equipment is placed in service. Star's obligation under this warranty is limited to the repair of defects without charge, by the factory authorized service agency or one of its sub-agencies. Models that are considered portable (*see below*) should be taken to the closest Star service agency, transportation prepaid.

- > Star will not assume any responsibility for loss of revenue.
- > On all shipments outside the United States and Canada, see International Warranty.
- * The warranty period for the JetStar six (6) ounce & Super JetStar eight (8) ounce series popcorn machines is two (2) years.
- * The warranty period for the Chrome-Max Griddles is five (5) years on the griddle surface. See detailed warranty provided with unit.
- * The warranty period for Teflon/Dura-Tec coatings is one year under normal use and reasonable care. This warranty does not apply if damage occurs to Teflon/Dura-Tec coatings from improper cleaning, maintenance, use of metallic utensils, or abrasive cleaners, abrasive pads, product identifiers and point-of-sale attachments, or any other non-food object that comes in continuous contact with the roller coating. This warranty does not apply to the "non-stick" properties of such materials.
- > This warranty does not apply to "Special Products" but to regular catalog items only. Star's warranty on "Special Products" is six (6) months on parts and ninety (90) days on labor.
- > This warranty does not apply to any item that is disassembled or tampered with for any purpose other than repair by a Star Authorized Service Center or the Service Center's sub-agency.
- > This warranty does not apply if damage occurs from improper installation, misuse, wrong voltage, wrong gas or operated contrary to the Installation and Operating instructions.
- > This warranty is not valid on Conveyor Ovens *unless* a "start-up/check-out" has been performed by a Factory Authorized Technician.

PARTS WARRANTY

Parts that are sold to repair out of warranty equipment are warranted for ninety (90) days. The part only is warranted. Labor to replace the part is chargeable to the customer.

SERVICES NOT COVERED BY WARRANTY

1. Travel time and mileage rendered beyond the 50 mile radius limit
2. Mileage and travel time on portable equipment (*see below*)
3. Labor to replace such items that can be replaced easily during a daily cleaning routine, ie; removable kettles on fryers, knobs, grease drawers on griddles, etc.
4. Installation of equipment
5. Damages due to improper installation
6. Damages from abuse or misuse
7. Operated contrary to the Operating and Installation Instructions
8. Cleaning of equipment
9. Seasoning of griddle plates
10. Voltage conversions
11. Gas conversions
12. Pilot light adjustment
13. Miscellaneous adjustments
14. Thermostat calibration and by-pass adjustment
15. Resetting of circuit breakers or safety controls or reset buttons
16. Replacement of bulbs
17. Replacement of fuses
18. Repair of damage created during transit, delivery, & installation OR created by acts of God

PORTABLE EQUIPMENT

Star will not honor service bills that include travel time and mileage charges for servicing any products considered "Portable" including items listed below. These products should be taken to the Service Agency for repair:

- * The Model 510FD Fryer.
- * The Model 526TOA Toaster Oven.
- * The Model J4R, 4 oz. Popcorn Machine.
- * The Model 518CMA & 526CMA Cheese Melter.
- * The Model 12MC & 15MC & 18MCP Hot Food Merchandisers.
- * The Model 12NCPW & 15NCPW Nacho Chip/Popcorn Warmer.
- * All Hot Dog Equipment **except Roller Grills & Drawer Bun Warmers.**
- * All Nacho Cheese Warmers **except Model 11WLA Series Nacho Cheese Warmer.**
- * All Condiment Dispensers **except the Model HPD & SPD Series Dispenser.**
- * All Specialty Food Warmers **except Model 130R, 11RW Series, and 11WSA Series.**
- * All QCS/RCS Series Toasters **except Model QCS3 & RCS3 Series.**
- * All Fast Steamer Models **except Direct Connect Series.**

ALL:

- * Pop-Up Toasters
- * Butter Dispensers
- * Pretzel Merchandisers
(Model 16PD-A Only)
- * Pastry Display Cabinets
- * Nacho Chip Merchandisers
- * Accessories of any kind
- * Sneeze Guards
- * Pizza Ovens
(Model PO12 Only)
- * Heat Lamps
- * Pumps-Manual

The foregoing warranty is in lieu of any and all other warranties expressed or implied and constitutes the entire warranty.

FOR ASSISTANCE

Should you need any assistance regarding the Operation or Maintenance of any Star equipment; write, phone, fax or email our Service Department. In all correspondence mention the Model number and the Serial number of your unit, and the voltage or type of gas you are using.

MATERIAL ~ FINISH ~ MODEL NO. 16PD-A PART NO. SK1532

DRJS CK. DATE 6-13-97 TITLE WIRING DIAGRAM
 LIMITS UNLESS OTHERWISE NOTED ST. LOUIS, MO 63143
 FRACTIONS ± 1/64 DECIMALS ± .005

CHANGES LTR DATE CHANGE DR

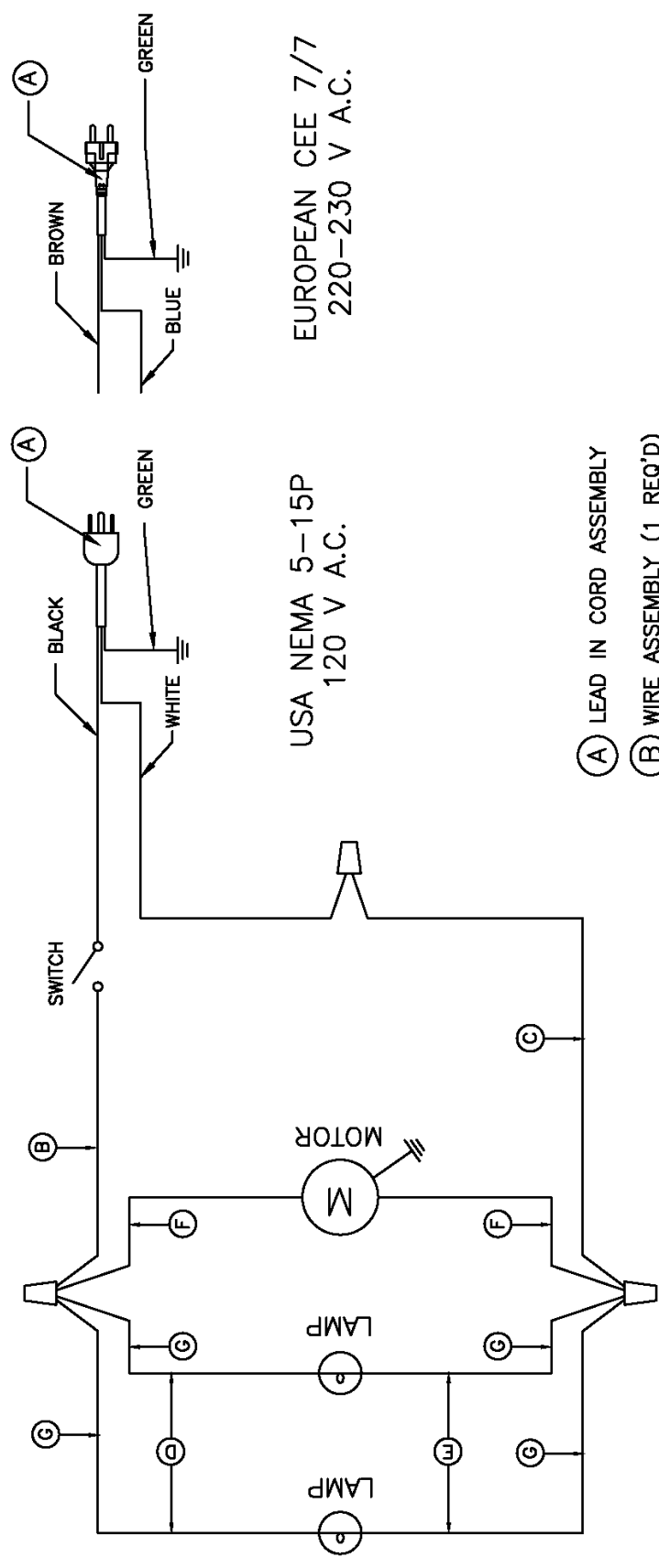

USA NEMA 5-15P
 120 V A.C.

EUROPEAN CEE 7/7
 220-230 V A.C.

- (A) LEAD IN CORD ASSEMBLY
- (B) WIRE ASSEMBLY (1 REQ'D)
- (C) WIRE ASSEMBLY (1 REQ'D)
- (D) WIRE LEAD FROM LIGHT SOCKET
- (E) WIRE LEAD FROM LIGHT SOCKET
- (F) WIRE ASSEMBLY (2 REQ'D.)
- (G) WIRE LEAD (240VE MODELS ONLY)

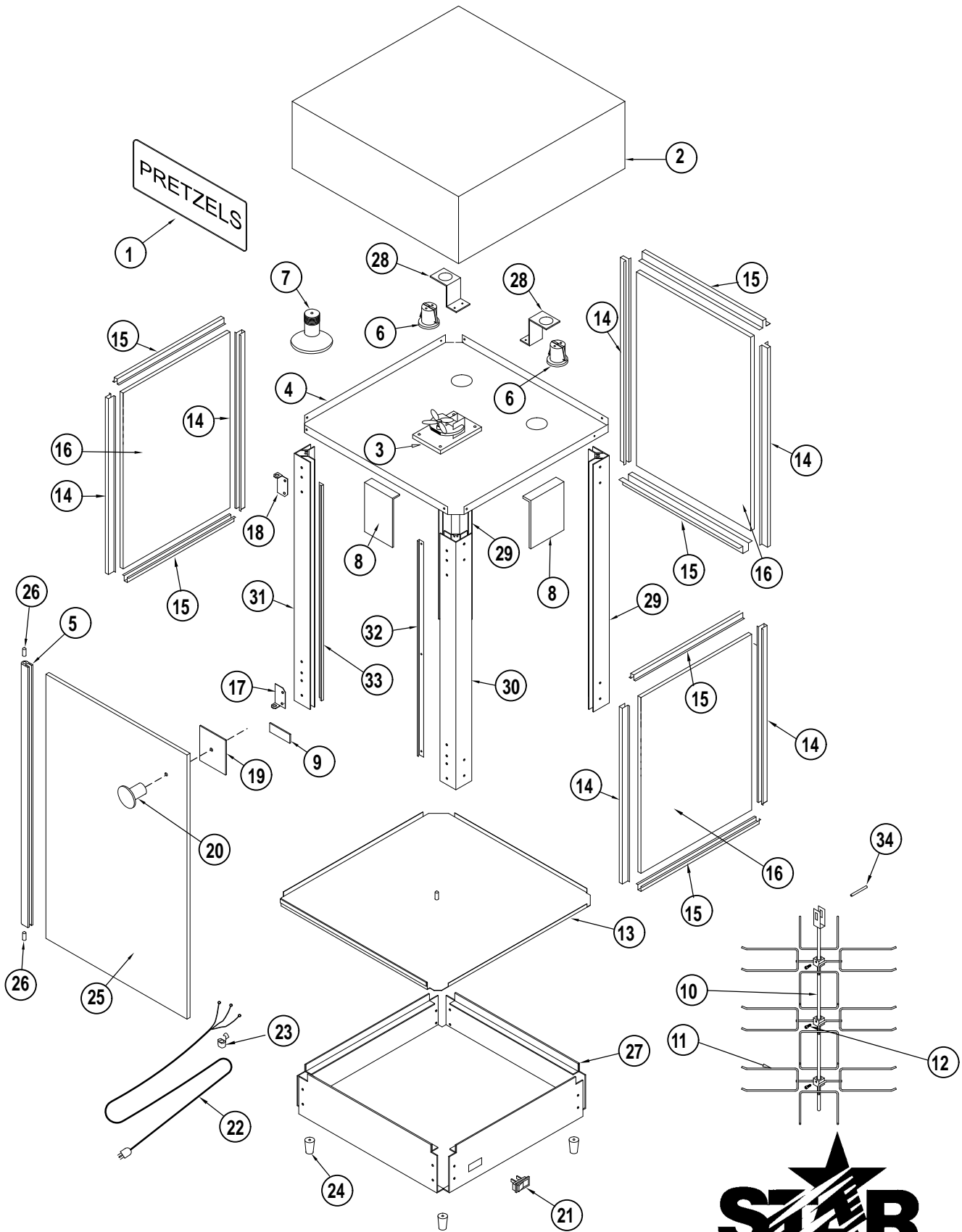

SOME ITEMS ARE INCLUDED FOR ILLUSTRATIVE PURPOSES ONLY AND IN CERTAIN INSTANCES MAY NOT BE AVAILABLE

MODEL - 16PD-A

STAR MANUFACTURING INTERNATIONAL, INC.

SK1535

REV. B

11/3/05

PARTS LIST

January 13, 2010, Rev K

15PDC-A Pastry Display Cabinet
 MODEL 16PD-A Pretzel Display Cabinet

| Key Number | Part Number | Number Per Unit | Description and Model Designation |
|------------|-------------|-----------------|---|
| 1 | 2M-Y6654 | 2 | SIGN-FRESH DONUT 15PDC-A |
| | 2M-Y4528 | 1 | SIGN-PRETZEL 16PD-A |
| 2 | C6-Y8239 | 1 | TOP |
| 3 | 2U-Y6953 | 1 | MOTOR 120V 16PD-A |
| | 2U-Y6954 | 1 | MOTOR 240VE 16PD-A |
| -- | 2I-H6579 | | GROMMET (not shown) |
| 4 | C6-Y8247 | 1 | TOP LINER |
| 5 | -- | 1 | HINGE DOOR (SUPPLIED WITH ITEM 25) |
| 6 | 2E-Y5921 | 2 | SOCKET-LAMP SPRING 120V 16PD-A |
| | 2E-Y9433 | | SOCKET-LAMP SPRING 240VE 16PD-A |
| 7 | 2S-Y4584 | 2 | LAMP 120V |
| | 2S-Z0630 | | LAMP 230CE |
| 8 | C4-Y4616 | 2 | LAMP SHIELD |
| 9 | C5-Y4172 | 1 | MAGNET TAPE |
| 10 | C4-Y8278 | 3 | SHELF-RACK 15PDC-A |
| | 2A-16007 | 1 | SHAFT ASSEMBLY 16PD-A |
| 11 | C4-15045 | 1 | RACK ASSEMBLY 15PDC-A |
| | 2B-Z6899 | 3 | HOLDER ASSEMBLY-ELECTROPLATE 16PD-A |
| 12 | -- | 3 | SOCKET HEAD CAP SCREW (SUPPLIED WITH ITEM 11) |
| 13 | C6-16012 | 1 | BOTTOM PAN-ASSEMBLY |
| 14 | 2I-Y7443 | 6 | CHANNEL GLASS (VERTICAL) |
| 15 | 2I-Y8169 | 6 | CHANNEL GLASS (HORIZONTAL) |
| 16 | 2Q-Y8165 | 3 | GLASS SIDE |
| 17 | C3-Y7377 | 1 | BRACKET HINGE LEFT |
| 18 | C3-Y7446 | 1 | BRACKET HINGE RIGHT |
| 19 | C6-Y7211 | 1 | STRIKE |
| 20 | 2R-Z0872 | 1 | KNOB |
| | 2C-1492 | 1 | SCREW 8-32 x 1/4 |
| 21 | 2E-Y6144 | 1 | SWITCH 16PD-A |
| 22 | C5-12004 | 1 | POWER CORD ASSEMBLY 120V 16PD-A |
| | C6-16016 | | POWER CORD ASSEMBLY 240VE 16PD-A |
| 23 | 2K-7889 | 1 | BUSHING HEYCO 16PD-A |
| 24 | 2I-H7685 | 4 | FOOT |
| 25 | C6-16011 | 1 | DOOR |
| 26 | -- | 2 | PIN-DRIVE 1/4 X 1" LONG (SUPPLIED WITH ITEM 25) |
| 27 | C4-Y8179 | 1 | BOTTOM |
| 28 | C6-Y6942 | 2 | LAMP CLIP 16PD-A |
| 29 | C6-Y8240 | 2 | CORNER POST |
| 30 | C6-Y8241 | 1 | CORNER POST-WIRE |
| 31 | C6-Y8242 | 1 | CORNER POST-DOOR |
| 32 | C6-Y8245 | 1 | FILLER RIGHT CORNER POST |
| 33 | C6-Y8246 | 1 | FILLER LEFT CORNER POST |
| 34 | 2A-Y1110 | 1 | PIN-ROLL |

**IMPORTANT: WHEN ORDERING, SPECIFY VOLTAGE OR TYPE GAS DESIRED
 INCLUDE MODEL AND SERIAL NUMBER**

PAGE 1
 OF 1

Some items are included for illustrative purposes only and in certain instances may not be available.



Star Manufacturing International, Inc.

STAR INTERNATIONAL HOLDINGS INC. COMPANY
Star - Holman - Lang - Wells - Bloomfield - Toastmaster
10 Sunnen Drive, St. Louis, MO 63143 U.S.A.
(314) 678-6303
www.star-mfg.com