



**Star
Manufacturing
International Inc.**

10 Sunnen Drive
St. Louis, MO 63143

Phone: (314) 781-2777
FAX: (314) 781-2714

**Installation
and
Operating
Instructions**

2M-Y4404 Rev. F 2-2-2007

STA-RITE HEAT LAMP

MODELS 14HL, 14HLR 34HL, 34HLR

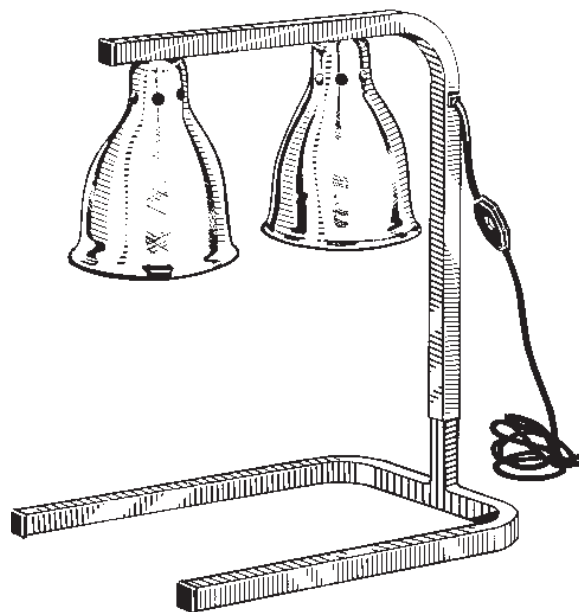

Model 14-HL



GENERAL INSTALLATION DATA



CAUTION

This equipment is designed and sold for commercial use only by personnel trained and experienced in its operation and is not sold for consumer use in and around the home nor for use directly by the general public in food service locations. For equipment to be used by the general public, please contact the factory.

VOLTAGE

These heat lamps are equipped for use on the voltage specified on the nameplate.



WARNING

DO NOT CONNECT TO ANY OTHER TYPE OF CURRENT OR THE MACHINE WILL BE SERIOUSLY DAMAGED.

GENERAL OPERATING INSTRUCTIONS

On the 14HL models, the height of the lamps is controlled by a thumb screw on the side of the lamp arm.

On the 34HL models, assemble the two "T" base assemblies to the tray assembly using the sheet metal screws provided.

Lamps are controlled by a switch on the cord assembly (14HL, 14HLR) and by a switch mounted on the arm assembly (34HL, 34HLR).

CLEANING

1. Disconnect electrical cord before cleaning.



CAUTION

ALLOW UNIT TO COOL PRIOR TO CLEANING.

2. To maintain finish and shine of unit, wipe arm, pan and screen with a damp cloth and a mild soap. Do not use harsh detergents or scouring pads.

MAINTENANCE AND REPAIRS

Contact the factory, a service representative or a local service company for service or required maintenance.

THOROUGHLY INSPECT YOUR UNIT ON ARRIVAL

This unit has been tested for proper operation before leaving our plant to insure delivery of your unit in perfect condition. However, there are instances in which the unit may be damaged in transit. In the event you discover any type of damage to your product upon receipt, you must immediately contact the transportation company who delivered the item to you and initiate your claim with same. If this procedure is not followed, it may affect the warranty status of the unit.

LIMITED EQUIPMENT WARRANTY

All workmanship and material in Star products have a one (1) year limited warranty on parts & labor in the United States and Canada. Such warranty is limited to the original purchaser only and shall be effective from the date the equipment is placed in service. Star's obligation under this warranty is limited to the repair of defects without charge, by the factory authorized service agency or one of its sub-agencies. Models that are considered portable (*see below*) should be taken to the closest Star service agency, transportation prepaid.

- > Star will not assume any responsibility for loss of revenue.
- > On all shipments outside the United States and Canada, see International Warranty.
- * The warranty period for the JetStar six (6) ounce & Super JetStar eight (8) ounce series popcorn machines is two (2) years.
- * The warranty period for the Chrome-Max Griddles is five (5) years on the griddle surface. See detailed warranty provided with unit.
- * The warranty period for Teflon/Dura-Tec coatings is one year under normal use and reasonable care. This warranty does not apply if damage occurs to Teflon/Dura-Tec coatings from improper cleaning, maintenance, use of metallic utensils, or abrasive cleaners. This warranty does not apply to the "non-stick" properties of such materials.
- > This warranty does not apply to "Special Products" but to regular catalog items only. Star's warranty on "Special Products" is six (6) months on parts and ninety (90) days on labor.
- > This warranty does not apply to any item that is disassembled or tampered with for any purpose other than repair by a Star Authorized Service Center or the Service Center's sub-agency.
- > This warranty does not apply if damage occurs from improper installation, misuse, wrong voltage, wrong gas or operated contrary to the Installation and Operating instructions.
- > This warranty is not valid on Conveyor Ovens *unless* a "start-up/check-out" has been performed by a Factory Authorized Technician.

PARTS WARRANTY

Parts that are sold to repair out of warranty equipment are warranted for ninety (90) days. The part only is warranted. Labor to replace the part is chargeable to the customer.

SERVICES NOT COVERED BY WARRANTY

- | | |
|--|---|
| 1. Travel time and mileage rendered beyond the 50 mile radius limit | 10. Voltage conversions |
| 2. Mileage and travel time on portable equipment (<i>see below</i>) | 11. Gas conversions |
| 3. Labor to replace such items that can be replaced easily during a daily cleaning routine, ie; removable kettles on fryers, knobs, grease drawers on griddles, etc. | 12. Pilot light adjustment |
| 4. Installation of equipment | 13. Miscellaneous adjustments |
| 5. Damages due to improper installation | 14. Thermostat calibration and by-pass adjustment |
| 6. Damages from abuse or misuse | 15. Resetting of circuit breakers or safety controls or reset buttons |
| 7. Operated contrary to the Operating and Installation Instructions | 16. Replacement of bulbs |
| 8. Cleaning of equipment | 17. Replacement of fuses |
| 9. Seasoning of griddle plates | 18. Repair of damage created during transit, delivery, & installation OR created by acts of God |

PORTABLE EQUIPMENT

Star will not honor service bills that include travel time and mileage charges for servicing any products considered "Portable" including items listed below. These products should be taken to the Service Agency for repair:

- * The Model 510FD Fryer.
- * The Model J4R, 4 oz. Popcorn Machine.
- * The Model 518CMA & 526CMA Cheese Melter.
- * The Model 12MC & 15MC & 18MCP Hot Food Merchandisers.
- * The Model 12NCPW & 15NCPW Nacho Chip/Popcorn Warmer.
- * All Hot Dog Equipment **except Roller Grills & Drawer Bun Warmers.**
- * All Nacho Cheese Warmers **except Model 11WLA Series Nacho Cheese Warmer.**
- * All Condiment Dispensers **except the Model HPDE, & SPDE Series Dispenser.**
- * All Specialty Food Warmers **except Model 130R, 11RW Series, and 11WSA Series.**
- * All QCS/RCS Series Toasters **except Model QCS3 & RCS3 Series.**

ALL:

- * Pop-Up Toasters
- * Butter Dispensers
- * Pretzel Merchandisers
- * Pastry Display Cabinets
- * Nacho Chip Merchandisers
- * Accessories of any kind
- * Sneeze Guards
- * Pizza Ovens
- * Heat Lamps
- * Pumps

The foregoing warranty is in lieu of any and all other warranties expressed or implied and constitutes the entire warranty.

FOR ASSISTANCE

Should you need any assistance regarding the Operation or Maintenance of any Star equipment; write, phone, fax or email our Service Department. In all correspondence mention the Model number and the Serial number of your unit, and the voltage or type of gas you are using.

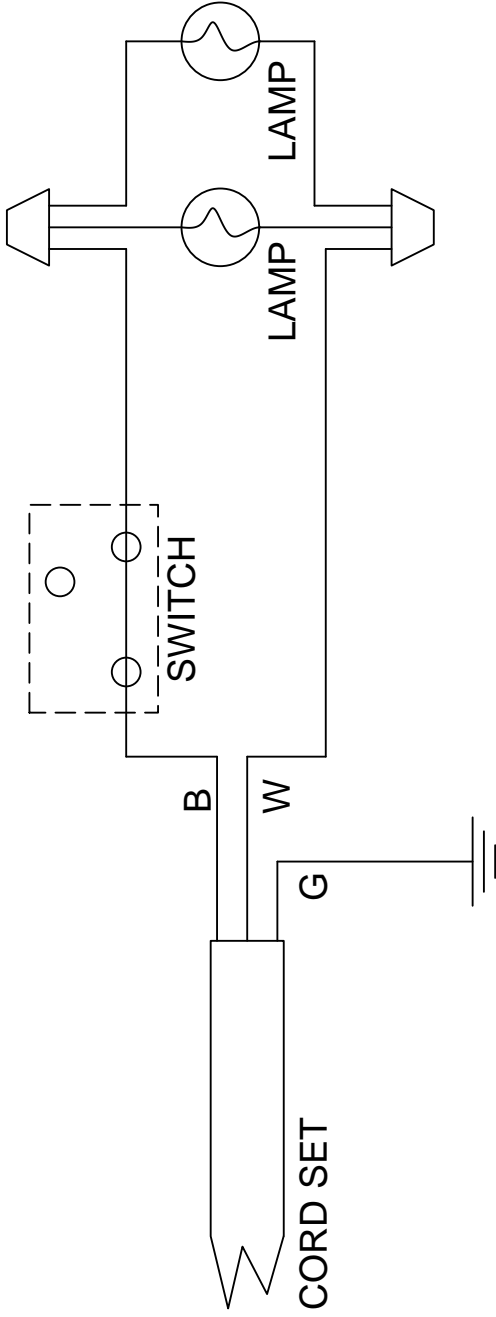

14 HL

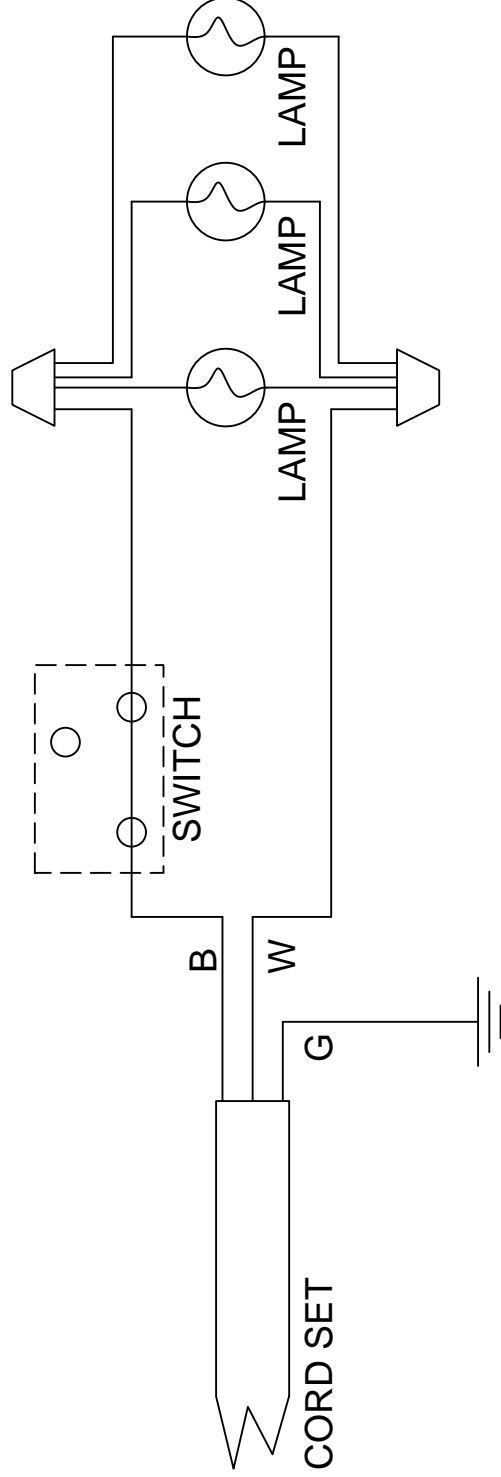

34 HL

MODEL: 14HL, 34HL

THIS DRAWING CONTAINS INFORMATION CONFIDENTIAL TO STAR MFG. INT'L. INC.
NO REPRODUCTION OR DISCLOSURE OF ITS CONTENTS IS PERMITTED.



STAR MANUFACTURING INTERNATIONAL INC.

SK1401

Rev -

10/25/1995

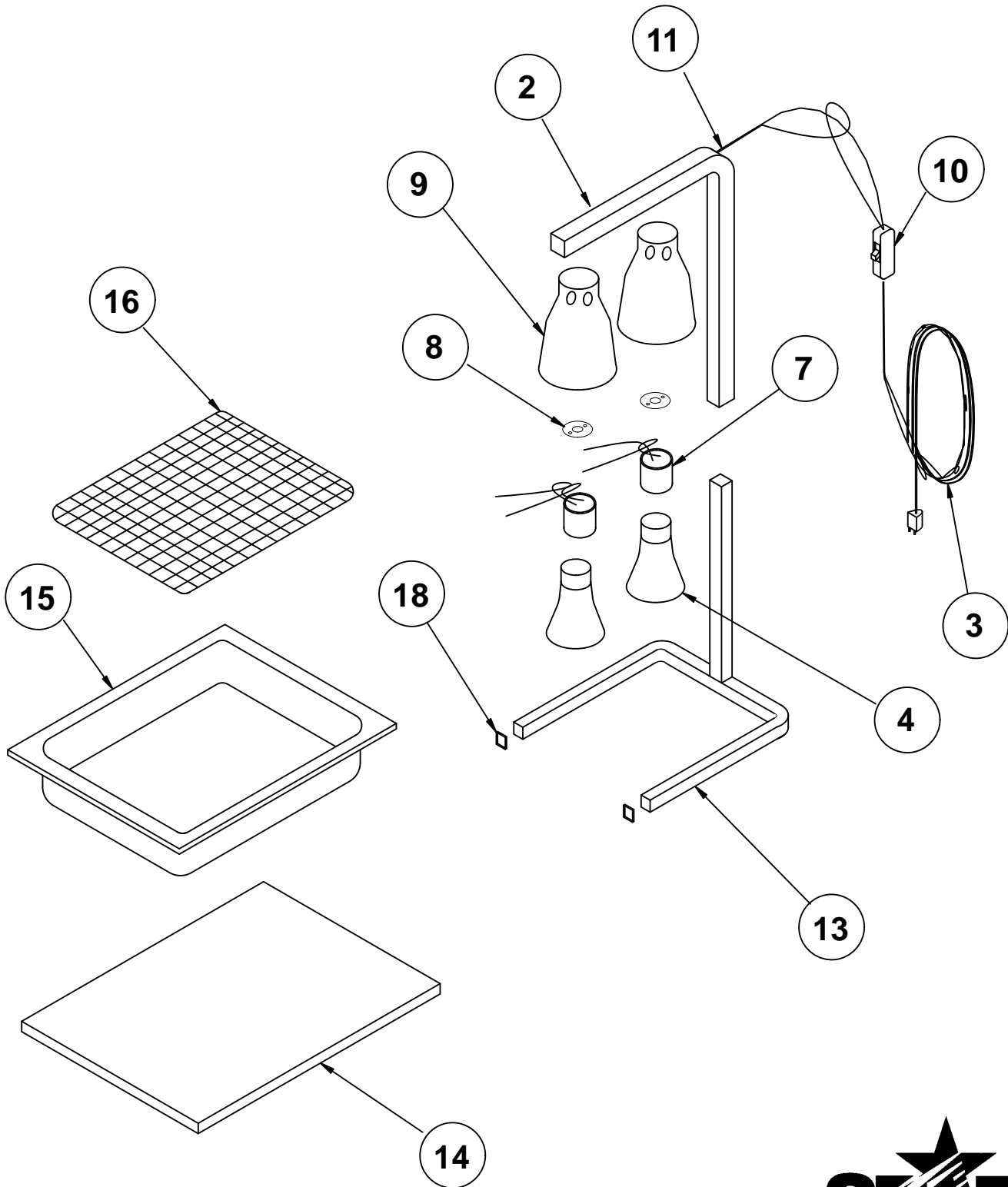

MODEL: 14HL, 14HLR 120V

STAR MANUFACTURING INTERNATIONAL, INC.

SK1397

REV A

10-24-95

PARTS LIST

February 2, 2007, Rev. F

MODEL 14HL, 14HL-2, 14HLR and 14HLR-2

Key Number	Part Number	Number Per Unit	Description
1-11	D1-143075	1	LAMP ARM ASSEMBLY COMPLETE (LAMPS NOT INCLUDED)
2	D1-143071	1	LAMP ARM ASSEMBLY
	2C-Y1545	1	NUT-WELD (WELDED TO LAMP ARM)
3	2E-Y1392	1	LEAD-IN-CORD ASSEMBLY with SWITCH
4	2S-Y2238	2	LAMP - INFRA-RED (WHITE) 14HL, 14HL-2
	2S-Y1508	2	LAMP - INFRA-RED (RED) 14HLR, 14HLR-2
7	2E-Y5636	2	SOCKET - PORCELAIN with 31" LEADS
8	2H-Y1119	2	GASKET - SOCKET
9	2L-Y1112	2	REFLECTOR
10	2E-Y1241	1	SWITCH
11	2K-H5417	1	BUSHING-CORD
13	D1-143072	1	LAMP BASE ASSEMBLY
	2C-Y1546	1	THUMB SCREW (NOT SHOWN)
14	D1-Y1111	1	TRAY - BASE 14HL, 14HLR
15	2D-Y1143	1	PAN - ALUMINUM (FULL SIZE) 14HL, 14HLR
	8V-P-1220	1	PAN 12" X 20" X 2 1/2"
16	D1-Z0771	1	SCREEN 14HL, 14HLR
	2A-H7804	4	FOOT (NOT SHOWN)
	2P-Y1547	3	PLUG - PLASTIC (NOT SHOWN)
	2K-Y1139	2	BUSHING - SNAP (NOT SHOWN)

**IMPORTANT: WHEN ORDERING, SPECIFY VOLTAGE OR TYPE GAS DESIRED
INCLUDE MODEL AND SERIAL NUMBER**

PAGE 1
OF 1

Some items are included for illustrative purposes only and in certain instances may not be available.



Star Manufacturing International, Inc.

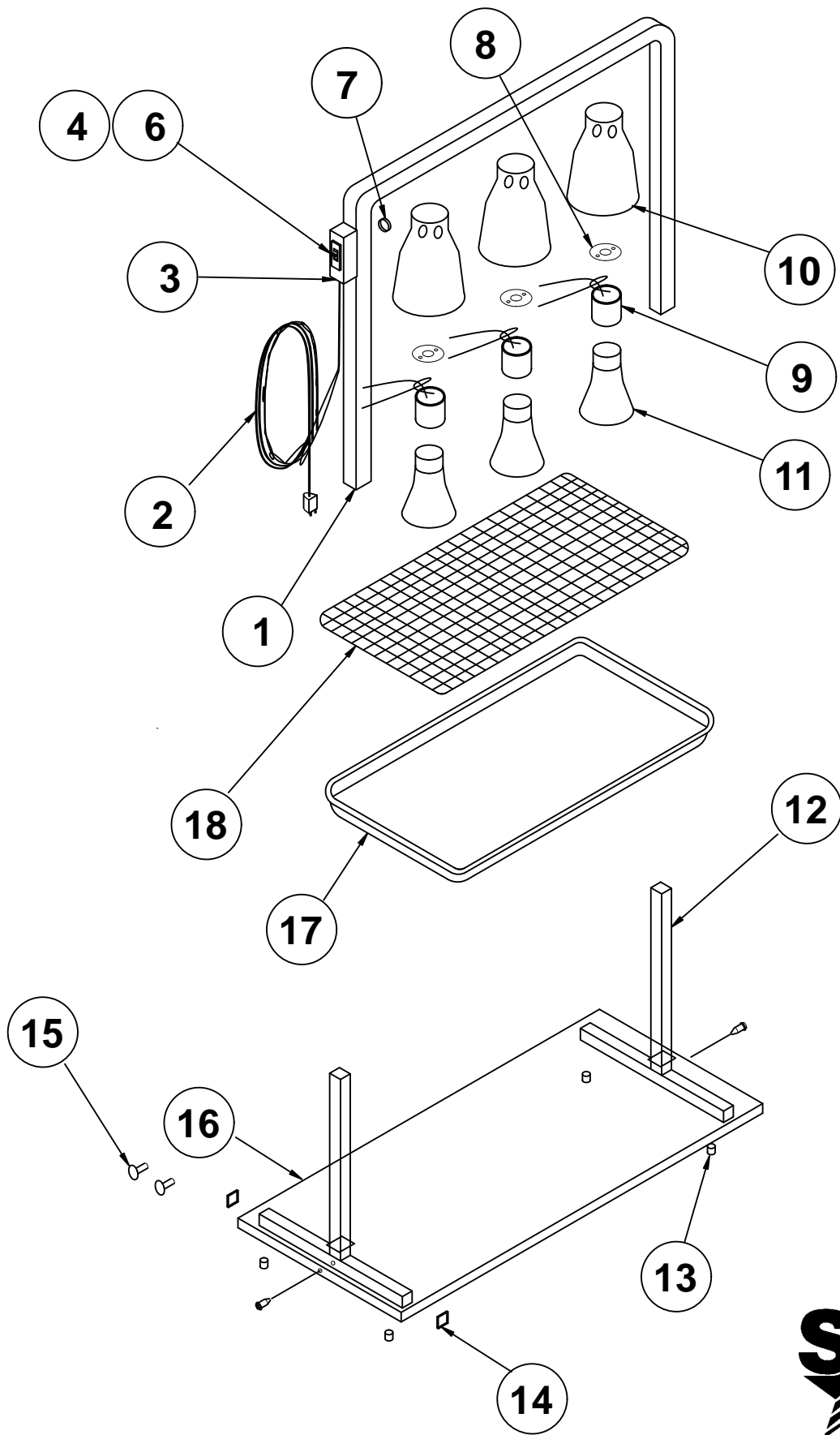

MODEL: 34HL, 34HLR 120V

STAR MANUFACTURING INTERNATIONAL, INC.

SK1400

REV A

2-2-07

PARTS LIST

February 2, 2007, Rev. F

MODEL 14HL, 14HL-2, 14HLR and 14HLR-2

Key Number	Part Number	Number Per Unit	Description
1-10	D2-143105	1	LAMP ARM ASSEMBLY COMPLETE (LAMPS NOT INCLUDED)
1	D2-143104	1	LAMP ARM ASSEMBLY
	2C-Y1545	1	NUT-WELD (WELDED TO LAMP ARM)
2	D2-143110	1	LEAD-IN-CORD ASSEMBLY with SWITCH
3	2K-H5417	1	BUSHING - CORD
4	D2-Y1539	1	SWITCH BOX
5	D2-143101	1	COVER - SWITCH BOX
6	2E-Y3070	1	SWITCH
7	2K-Y1139	6	BUSHING SNAP
8	2H-Y1119	3	GASKET - SOCKET
9	2E-Y5636	3	SOCKET - PORCELAIN with 31" LEADS
10	2L-Y1112	3	REFLECTOR
11	2S-Y1508	3	LAMP - INFRA-RED (RED) 34HLR, 34HLR-2
	2S-Y2238	3	LAMP - INFRA-RED (WHITE) 34HL, 34HL-2
12	D2-143103	2	LAMP "T" BASE ASSEMBLY
13	2A-H7804	4	FOOT
14	2P-Y1547	4	PLUG
15	2C-Y1546	2	THUMB SCREW
16	D2-143102	1	TRAY ASSEMBLY 34HL, 34HLR
17	2D-Y1548	1	PAN
18	D2-Y2479	1	SCREEN - TRAY
	2C-8823	2	SCREWS FOR HOLDING TRAY TO LEGS

**IMPORTANT: WHEN ORDERING, SPECIFY VOLTAGE OR TYPE GAS DESIRED
INCLUDE MODEL AND SERIAL NUMBER**

PAGE 1
OF 1

Some items are included for illustrative purposes only and in certain instances may not be available.



Star Manufacturing International, Inc.