

TP/HT/BTW Series Slot Toasters

Models:

- TP209
- TP224
- TP409
- TP424
- TP430
- HT409
- HT424
- BTW09
- BTW24

PARTS MANUAL

for domestic and standard export toasters

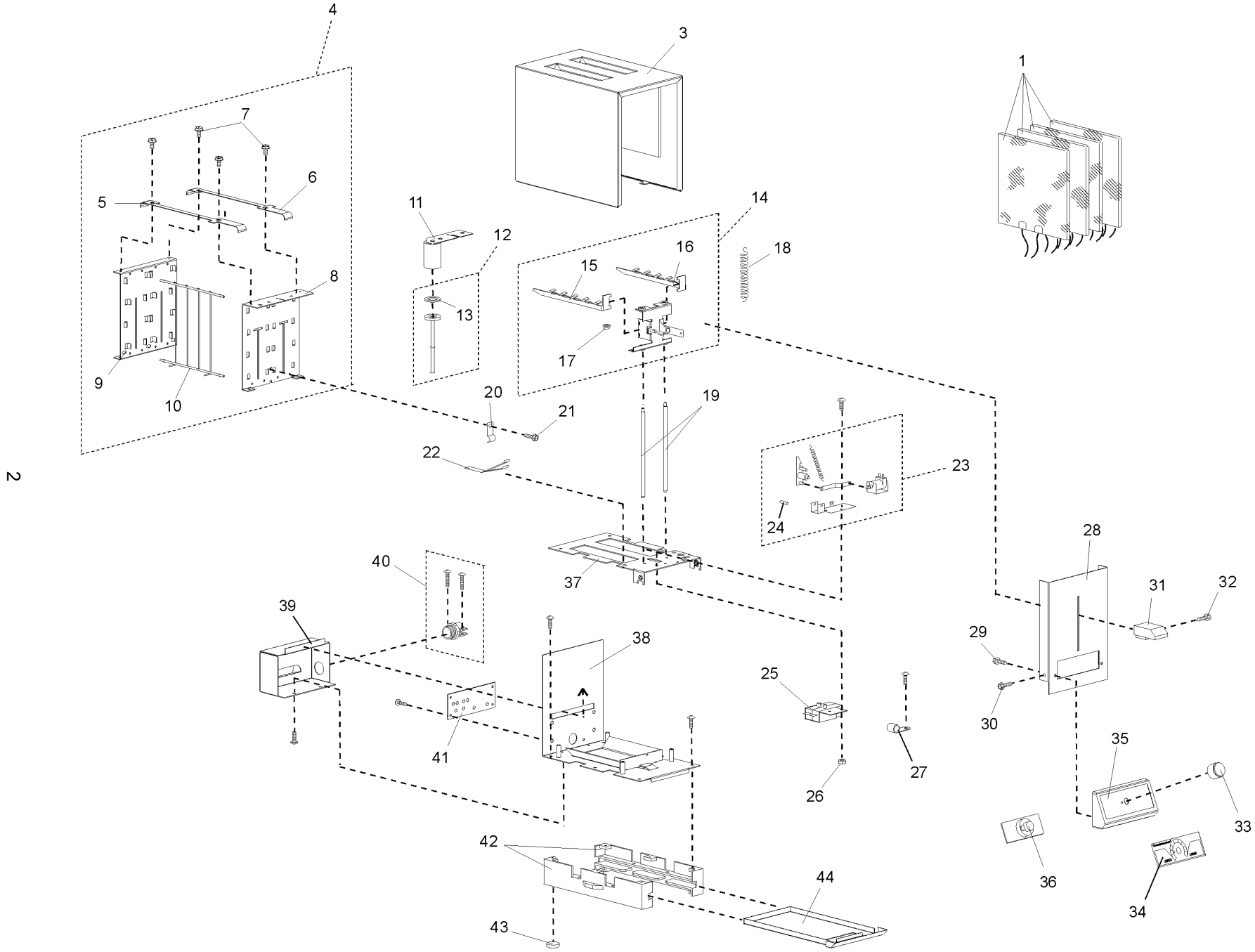
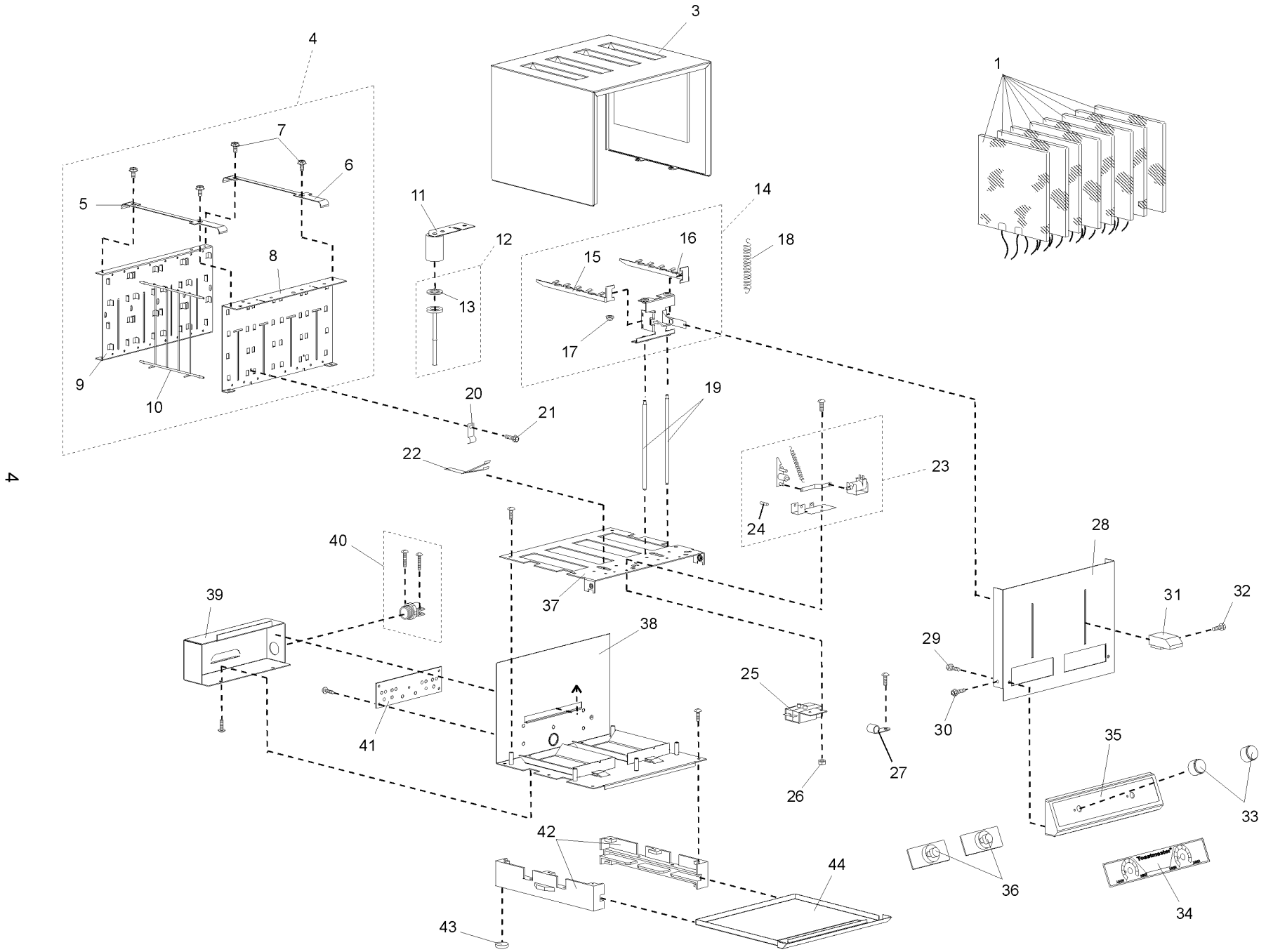
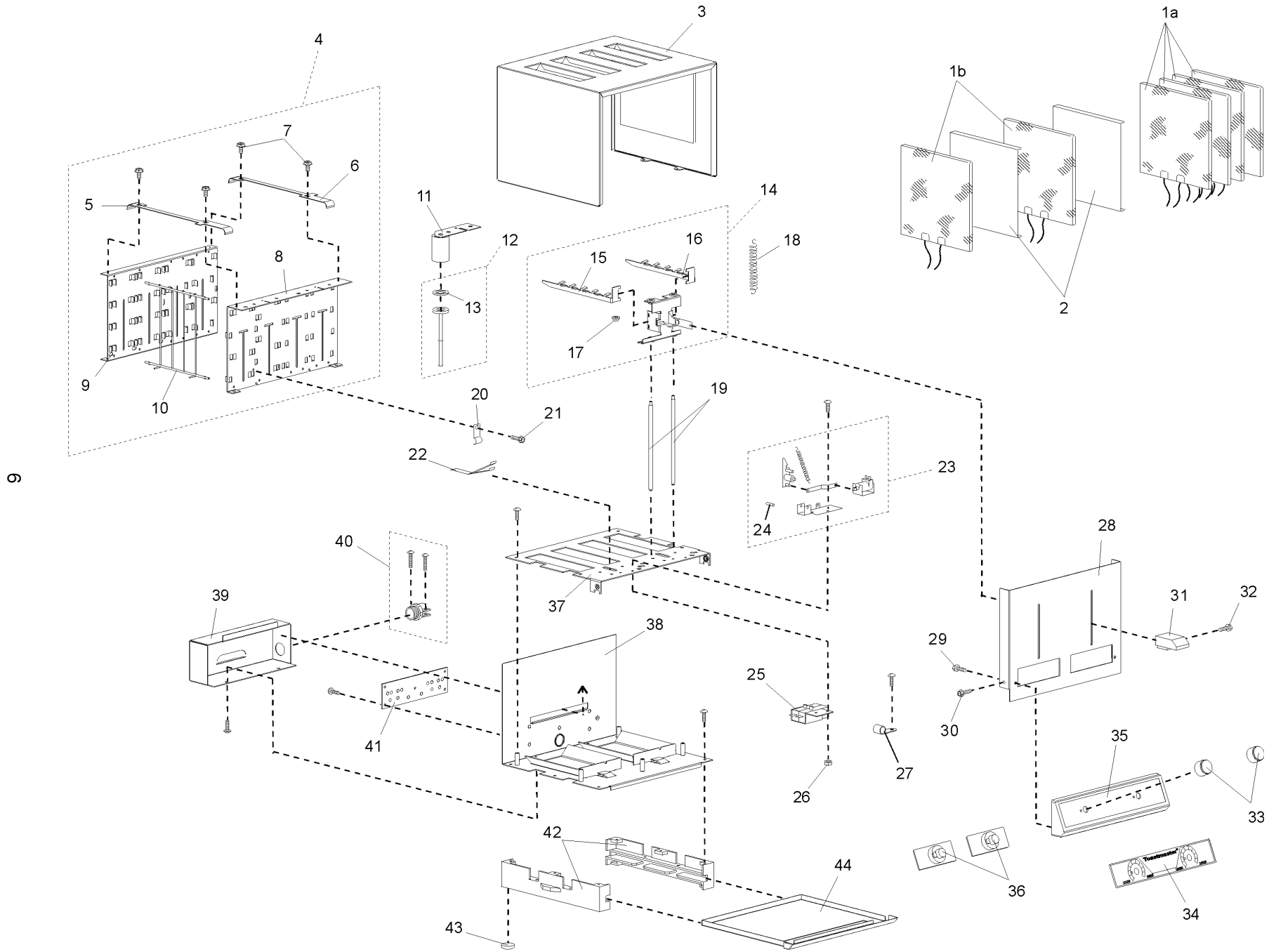

Fig No	Description	TP209		TP224	
		Qty	P/N	Qty	P/N
1	ELEMENT - 120V, 275W	4	2N-3001805	--	--
	ELEMENT - 120V, 325W	--	--	4	2N-3001806
3	TOP CVR W / INSULATION	1	A8-35404	1	A8-35404
4	ASSY, HEAT SHIELDS & GUARDS	1	A8-35289	1	A8-35289
5	STRINGER SUPPORT SPACER, LT	1	A8-32523	1	A8-32523
6	STRINGER SUPPORT SPACER, RT	1	A8-34455	1	A8-34455
7	SCREW, 6 x 3/8", "AB" SLT HWH	4	2C-2000634	4	2C-2000634
8	HEAT SHIELD, FRONT	1	A8-35229	1	A8-35229
9	HEAT SHIELD, REAR	1	A8-35280	1	A8-35280
10	ASSY, ROD & GUARD	4	2V-32527	4	2V-32527
11	PISTON BRACKET & CYLINDER	1	A8-7606061	1	A8-7606061
12	ASSY, PISTON	1	A8-7606063	1	A8-7606063
13	PISTON RING	1	A8-7002280	1	A8-7002280
14	ASSY, SUPPORT & ELEVATOR	1	A8-32540	1	A8-32540
15	BREAD SUPPORT, LT	1	A8-32541	1	A8-32541
16	BREAD SUPPORT, RT	1	A8-32542	1	A8-32542
17	BUSHING	4	2K-7002277	4	2K-7002277
18	EXTENSION SPRING	1	2P-3103246	1	2P-3103246
19	VERTICAL SHAFT	2	2A-7002276	2	2A-7002276
20	SENSOR BRACKET	1	A8-7001563	1	A8-7001563
21	SCREW, 6 x 3/8", "AB" SLT HWH	1	2C-2000634	1	2C-2000634
22	ACTUATOR	1	A8-7606066	1	A8-7606066
23	ASSY, SOLENOID & LATCH	1	A8-7606065	1	A8-7606065
24	ROLL PIN	1	2A-2002510	1	2A-2002510
25	SWITCH & BRACKET	1	A8-7604299	1	A8-7604299
26	NUT, #6-32 KEPS	2	2C-2001327	2	2C-2001327
27	WIRE CLAMP, PLASTIC	1	2C-3101206	1	2C-3101206
28	FRONT PLATE	1	A8-35368	1	A8-35368
29	SCREW, 6 x 3/8" "B" HWH	2	2C-B301A8861	2	2C-B301A8861
30	SCREW, 8-32 x 3/8" FLATHEAD	2	2C-21276-0046	2	2C-21276-0046
31	KNOB, MANUAL RELEASE	1	2R-3101757	1	2R-3101757
32	SCREW, "F" 6-32 x 1/4" PANHD, BLK	1	2C-K1DS213	1	2C-K1DS213
33	KNOB, DARK/LIGHT ADJUSTMENT	1	2R-39382	1	2R-39382
34	DECAL, CONTROL PANEL	1	2M-39413	1	2M-39413
35	CONTROL ENCLOSURE	1	2E-36025	1	2E-36025
36	ASSY, TIMER, 120V	1	2E-7606512	1	2J-7605984
37	CHASSIS TOP	1	A8-35305	1	A8-35305
38	ASSY, CHASSIS BOTTOM & BACK	1	2W-35327	1	2W-35327
39	REAR ELECTRICAL COVER	1	A8-35338	1	A8-35338
40	CABLE CLAMP, 3/8"	1	2C-3B82D8735	1	2C-3B82D8735
41	TERMINAL BOARD	1	2E-35340	1	2E-35340
42	BASE, BLACK PLASTIC	2	2D-3102164	2	2D-3102164
43	PAD, RUBBER FOOT	4	2A-K1DS268	4	2A-K1DS268
44	CRUMB TRAY	1	A8-35400	1	A8-35400
--	ASSY, CORD & PLUG, NEMA 5-15P (USA and Canada)	1	C515	--	--
--	ASSY, CORD & PLUG, NEMA 6-15P (USA and Canada)	--	--	1	2E-1D3S5
--	MANUAL, OWNER'S OPERATING	1	2M-41491	1	2M-41491



Item No	Description	TP409		TP424		TP430	
		Qty	P/N	Qty	P/N	Qty	P/N
1	ELEMENT - 120V, 275W	8	2N-3001805	--	--	--	--
	ELEMENT - 120V, 325W	--	--	8	2N-3001806	--	--
	ELEMENT - 104V, 325W	--	--	--	--	8	2N-3001804
3	TOP CVR W / INSULATION	1	A8-39295	1	A8-39295	1	A8-39295
4	ASSY, HEAT SHIELDS & GUARDS	1	A8-32539	1	A8-32539	1	A8-32539
5	STRINGER SUPPORT SPACER, LT	1	A8-32523	1	A8-32523	1	A8-32523
6	STRINGER SUPPORT SPACER, RT	1	A8-34455	1	A8-34455	1	A8-34455
7	SCREW, 6 x 3/8", "AB" SLT HWH	4	2C-2000634	4	2C-2000634	4	2C-2000634
8	HEAT SHIELD, FRONT	1	A8-32535	1	A8-32535	1	A8-32535
9	HEAT SHIELD, REAR	1	A8-34758	1	A8-34758	1	A8-34758
10	ASSY, ROD & GUARD	8	2V-32527	8	2V-32527	8	2V-32527
11	PISTON BRACKET & CYLINDER	2	A8-7606061	2	A8-7606061	2	A8-7606061
12	ASSY, PISTON	2	A8-7606063	2	A8-7606063	2	A8-7606063
13	PISTON RING	1	A8-7002280	1	A8-7002280	1	A8-7002280
14	ASSY, SUPPORT & ELEVATOR	2	A8-32540	2	A8-32540	2	A8-32540
15	BREAD SUPPORT, LT	1	A8-32541	1	A8-32541	1	A8-32541
16	BREAD SUPPORT, RT	1	A8-32542	1	A8-32542	1	A8-32542
17	BUSHING	4	2K-7002277	4	2K-7002277	4	2K-7002277
18	EXTENSION SPRING	2	2P-3103246	2	2P-3103246	2	2P-3103246
19	VERTICAL SHAFT	4	2A-7002276	4	2A-7002276	4	2A-7002276
20	SENSOR BRACKET	2	A8-7001563	2	A8-7001563	2	A8-7001563
21	SCREW, 6 x 3/8", "AB" SLT HWH	2	2C-2000634	2	2C-2000634	2	2C-2000634
22	ACTUATOR	2	A8-7606066	2	A8-7606066	2	A8-7606066
23	ASSY, SOLENOID & LATCH	2	A8-7606065	2	A8-7606065	2	A8-7606065
24	ROLL PIN	1	2A-2002510	1	2A-2002510	1	2A-2002510
25	SWITCH & BRACKET, LT	1	A8-7604299	1	A8-7604299	1	A8-7604299
25	SWITCH & BRACKET, RT	1	A8-7604713	1	A8-7604713	1	A8-7604713
26	NUT, #6-32 KEPS	4	2C-2001327	4	2C-2001327	4	2C-2001327
27	WIRE CLAMP, PLASTIC	1	2C-3101206	1	2C-3101206	1	2C-3101206
28	FRONT PLATE	1	A8-39249	1	A8-39249	1	A8-39249
29	SCREW, 6 x 3/8" "B" HWH	2	2C-B301A8861	2	2C-B301A8861	2	2C-B301A8861
30	SCREW, 8-32 x 3/8" FLATHEAD	2	2C-21276-0046	2	2C-21276-0046	2	2C-21276-0046
31	KNOB, MANUAL RELEASE	2	2R-3101757	2	2R-3101757	2	2R-3101757
32	SCREW, "F" 6-32 x 1/4" PANHD, BLK	2	2C-K1DS213	2	2C-K1DS213	2	2C-K1DS213
33	KNOB, DARK/LIGHT ADJUSTMENT	2	2R-39382	2	2R-39382	2	2R-39382
34	DECAL, CONTROL PANEL	1	2M-39414	1	2M-39414	1	2M-39414
35	CONTROL ENCLOSURE	1	36027	1	36027	1	36027
36	ASSY, TIMER, 120V	2	2E-7606512	2	2E-7605984	--	--
	ASSY, TIMER, 104V	--	--	--	--	2	2E-7604901
37	CHASSIS TOP	1	A8-33310	1	A8-33310	1	A8-33310
38	ASSY, CHASSIS BOTTOM & BACK	1	2W-33309	1	2W-33309	1	2W-33309
39	REAR ELECTRICAL COVER	1	A8-32524	1	A8-32524	1	A8-32524
40	CABLE CLAMP, 3/8"	1	2C-3B82D8735	1	2C-3B82D8735	1	2C-3B82D8735
41	TERMINAL BOARD	1	2E-32323	1	2E-32323	1	2E-32323
42	BASE, BLACK PLASTIC	2	2D-3102164	2	2D-3102164	2	2D-3102164
43	PAD, RUBBER FOOT	4	2A-K1DS268	4	2A-K1DS268	4	2A-K1DS268
44	CRUMB TRAY	1	A8-7001948	1	A8-7001948	1	A8-7001948
--	ASSY, CORD & PLUG, NEMA 5-20P (USA Only)	1	2E-31785	--	--	--	--
--	ASSY, CORD & PLUG, NEMA 5-30P (Canada Only)	1	C530	--	--	--	--
--	ASSY, CORD & PLUG, NEMA 6-15P (USA and Canada)	--	--	1	2E-1D3S5	--	--
--	ASSY, CORD & PLUG, NEMA 6-20P (Canada Only)	--	--	--	--	1	C620
--	MANUAL, OWNER'S OPERATING	1	39533	1	2M-41491	1	2M-41491



Item No	Description	HT409		HT424	
		Qty	P/N	Qty	P/N
1a	ELEMENT, STANDARD SLOT - 120V, 275W	4	2N-3001805	--	--
1a	ELEMENT, STANDARD SLOT - 120V, 325W	--	--	4	2N-3001806
1b	ELEMENT, EXTRA-WIDE SLOT - 120V, 450W	2	2N-3001878	2	2N-3001878
2	PLATE, ELEMENT REPLACEMENT	2	A8-36853	2	A8-36853
3	TOP CVR W / INSULATION	1	A8-39865	1	A8-39865
4	ASSY, HEAT SHIELDS & GUARDS	1	A8-39873	1	A8-39873
5	STRINGER SUPPORT SPACER, LT	1	A8-32523	1	A8-32523
6	STRINGER SUPPORT SPACER, RT	1	A8-34455	1	A8-34455
7	SCREW, 6 x 3/8", "AB" SLT HWH	4	2C-2000634	4	2C-2000634
8	HEAT SHIELD, FRONT	1	A8-39863	1	A8-39863
9	HEAT SHIELD, REAR	1	A8-39864	1	A8-39864
10	ASSY, ROD & GUARD	4	2V-32527	4	2V-32527
11	PISTON BRACKET & CYLINDER	2	A8-7606061	2	A8-7606061
12	ASSY, PISTON	2	A8-7606063	2	A8-7606063
13	PISTON RING	1	A8-7002280	1	A8-7002280
14	ASSY, SUPPORT & ELEVATOR	2	A8-32540	2	A8-32540
15	BREAD SUPPORT, LT	1	A8-32541	1	A8-32541
16	BREAD SUPPORT, RT	1	A8-32542	1	A8-32542
17	BUSHING	4	2K-7002277	4	2K-7002277
18	EXTENSION SPRING	2	2P-3103246	2	2P-3103246
19	VERTICAL SHAFT	4	2A-7002276	4	2A-7002276
20	SENSOR BRACKET	2	A8-7001563	2	A8-7001563
21	SCREW, 6 x 3/8", "AB" SLT HWH	2	2C-2000634	2	2C-2000634
22	ACTUATOR	2	A8-7606066	2	A8-7606066
23	ASSY, SOLENOID & LATCH	2	A8-7606065	2	A8-7606065
24	ROLL PIN	1	2A-2002510	1	2A-2002510
25	SWITCH & BRACKET, LT	1	A8-7604299	1	A8-7604299
25	SWITCH & BRACKET, RT	1	A8-7604713	1	A8-7604713
26	NUT, #6-32 KEPS	4	2C-2001327	4	2C-2001327
27	WIRE CLAMP, PLASTIC	1	2C-3101206	1	2C-3101206
28	FRONT PLATE	1	A8-39249	1	A8-39249
29	SCREW, 6 x 3/8" "B" HWH	2	2C-B301A8861	2	2C-B301A8861
30	SCREW, 8-32 x 3/8" FLATHEAD	2	2C-21276-0046	2	2C-21276-0046
31	KNOB, MANUAL RELEASE	2	2R-3101757	2	2R-3101757
32	SCREW, "F" 6-32 x 1/4" PANHD, BLK	2	2C-K1DS213	2	2C-K1DS213
33	KNOB, DARK/LIGHT ADJUSTMENT	2	2R-39382	2	2R-39382
34	DECAL, CONTROL PANEL	1	2M-39414	1	2M-39414
35	CONTROL ENCLOSURE	1	36027	1	36027
36	ASSY, TIMER (LEFT SIDE - EXTRA-WIDESLOTS), 120/208/240V	1	2J-35736	1	2J-35736
36	ASSY, TIMER (RIGHT SIDE - STANDARD SLOTS), 120V	1	2E-7606512	1	2E-7606512
37	CHASSIS TOP	1	A8-33310	1	A8-33310
38	ASSY, CHASSIS BOTTOM & BACK	1	2W-33309	1	2W-33309
39	REAR ELECTRICAL COVER	1	A8-32524	1	A8-32524
40	CABLE CLAMP, 3/8"	1	2C-3B82D8735	1	2C-3B82D8735
41	TERMINAL BOARD	1	2E-32323	1	2E-32323
42	BASE, BLACK PLASTIC	2	2D-3102164	2	2D-3102164
43	PAD, RUBBER FOOT	4	2A-K1DS268	4	2A-K1DS268
44	CRUMB TRAY	1	A8-7001948	1	A8-7001948
--	ASSY, CORD & PLUG, NEMA 5-20P (USA and Canada)	1	2E-31785	--	--
--	ASSY, CORD & PLUG, NEMA 6-15P (USA and Canada)	--	--	1	2E-1D3S5
--	MANUAL, OWNER'S OPERATING	1	2M-41491	1	2M-41491

**TP/HT/BTW
Series**

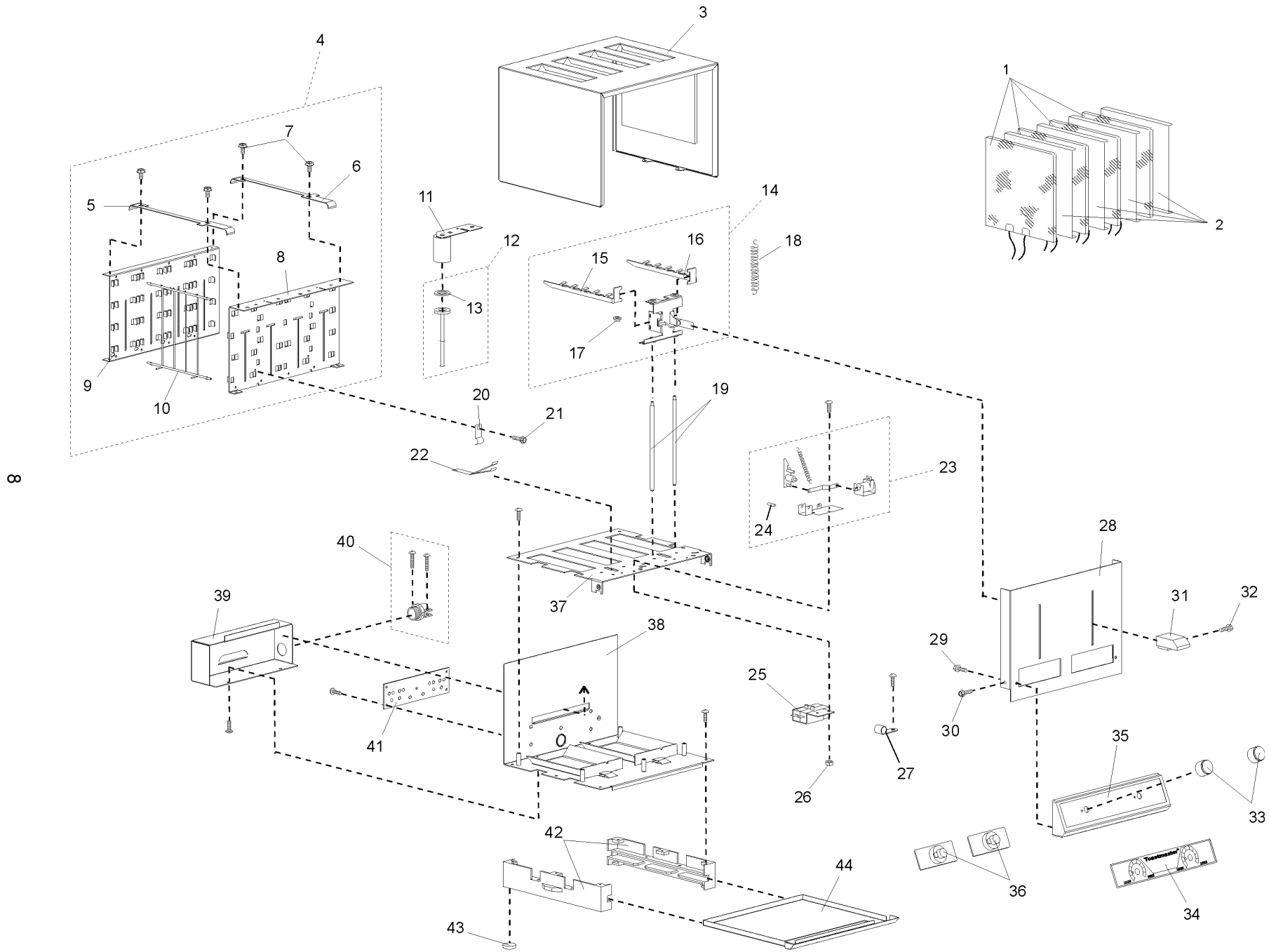

Item No	Description	BTW09		BTW24	
		Qty	P/N	Qty	P/N
1	ELEMENT - 120V, 450W	4	2N-3001878	4	2N-3001878
2	PLATE, ELEMENT REPLACEMENT	4	A8-36853	4	A8-36853
3	TOP CVR W / INSULATION	1	A8-39296	1	A8-39296
4	ASSY, HEAT SHIELDS & GUARDS	1	A8-36859	1	A8-36859
5	STRINGER SUPPORT SPACER, LT	1	A8-32523	1	A8-32523
6	STRINGER SUPPORT SPACER, RT	1	A8-34455	1	A8-34455
7	SCREW, 6 x 3/8", "AB" SLT HWH	4	2C-2000634	4	2C-2000634
8	HEAT SHIELD, FRONT	1	A8-36854	1	A8-36854
9	HEAT SHIELD, REAR	1	A8-36855	1	A8-36855
10	ASSY, ROD & GUARD	4	2V-32527	4	2V-32527
11	PISTON BRACKET & CYLINDER	2	A8-7606061	2	A8-7606061
12	ASSY, PISTON	2	A8-7606063	2	A8-7606063
13	PISTON RING	1	A8-7002280	1	A8-7002280
14	ASSY, SUPPORT & ELEVATOR	2	A8-32540	2	A8-32540
15	BREAD SUPPORT, LT	1	A8-32541	1	A8-32541
16	BREAD SUPPORT, RT	1	A8-32542	1	A8-32542
17	BUSHING	4	2K-7002277	4	2K-7002277
18	EXTENSION SPRING	2	2P-3103246	2	2P-3103246
19	VERTICAL SHAFT	4	2A-7002276	4	2A-7002276
20	SENSOR BRACKET	2	A8-7001563	2	A8-7001563
21	SCREW, 6 x 3/8", "AB" SLT HWH	2	2C-2000634	2	2C-2000634
22	ACTUATOR	2	A8-7606066	2	A8-7606066
23	ASSY, SOLENOID & LATCH	2	A8-7606065	2	A8-7606065
24	ROLL PIN	1	2A-2002510	1	2A-2002510
25	SWITCH & BRACKET, LT	1	A8-7604299	1	A8-7604299
25	SWITCH & BRACKET, RT	1	A8-7604713	1	A8-7604713
26	NUT, #6-32 KEPS	4	2C-2001327	4	2C-2001327
27	WIRE CLAMP, PLASTIC	1	2C-3101206	1	2C-3101206
28	FRONT PLATE	1	A8-39249	1	A8-39249
29	SCREW, 6 x 3/8" "B" HWH	2	2C-B301A8861	2	2C-B301A8861
30	SCREW, 8-32 x 3/8" FLATHEAD	2	2C-21276-0046	2	2C-21276-0046
31	KNOB, MANUAL RELEASE	2	2R-3101757	2	2R-3101757
32	SCREW, "F" 6-32 x 1/4" PANHD, BLK	2	2C-K1DS213	2	2C-K1DS213
33	KNOB, DARK/LIGHT ADJUSTMENT	2	2R-39382	2	2R-39382
34	DECAL, CONTROL PANEL	1	2M-39414	1	2M-39414
35	CONTROL ENCLOSURE	1	36027	1	36027
36	ASSY, TIMER, 120/208/240V	2	2J-35736	2	2J-35736
37	CHASSIS TOP	1	A8-33310	1	A8-33310
38	ASSY, CHASSIS BOTTOM & BACK	1	2W-33309	1	2W-33309
39	REAR ELECTRICAL COVER	1	A8-32524	1	A8-32524
40	CABLE CLAMP, 3/8"	1	2C-3B82D8735	1	2C-3B82D8735
41	TERMINAL BOARD	1	2E-32323	1	2E-32323
42	BASE, BLACK PLASTIC	2	2D-3102164	2	2D-3102164
43	PAD, RUBBER FOOT	4	2A-K1DS268	4	2A-K1DS268
44	CRUMB TRAY	1	A8-7001948	1	A8-7001948
--	ASSY, CORD & PLUG, NEMA 5-20P (USA and Canada)	1	2E-31785	--	--
--	ASSY, CORD & PLUG, NEMA 6-15P (USA and Canada)	--	--	1	2E-1D3S5
--	MANUAL, OWNER'S OPERATING	1	2M-41491	1	2M-41491

WARNING

Improper installation, adjustment, alteration, service or maintenance can cause property damage, injury or death. Read the installation, operating and maintenance instructions thoroughly before installing or servicing this equipment.

NOTICE

During the warranty period, ALL parts replacement and servicing should be performed by your Toastmaster Authorized Service Agent. Service that is performed by parties other than your Toastmaster Authorized Service Agent may void your warranty.

NOTICE

Using any parts other than genuine Toastmaster factory manufactured parts relieves the manufacturer of all warranty and liability.

NOTICE

Toastmaster reserves the right to change specifications at any time.

STAR INTERNATIONAL HOLDINGS INC. COMPANY

Star - Holman - Lang - Wells - Bloomfield - Toastmaster

10 Sunnen Drive, St. Louis, MO 63143 U.S.A.

(800) 807-9054 (314) 781-2777

Parts & Service (800) 807-9054

www.star-mfg.com