

Project	Quantity	Item #
Model Specified:		CSI Section 11400

Compact Undercounter Refrigerator and Freezer Models/Self-Contained



Model UHT27-R
(shown with optional casters)

27", 48" & 60" Wide Models



27" One Door Refrigerator Hinged Left	UHT27-L
27" One Door Refrigerator Hinged Right Model	UHT27-R
48" Two Door Refrigerator Hinged Left/Right	UHT48-LR
60" Two Door Refrigerator Hinged Left/Right	UHT60-LR



27" One Door Freezer Hinged Left	ULT27-L
27" One Door Freezer Hinged Right Model	ULT27-R
48" Two Door Freezer Hinged Left/Right	ULT48-LR
60" Two Door Freezer Hinged Left/Right	ULT60-LR

Traulsen's durable, high performance, compact undercounter refrigerator and freezer models provide a high quality/high value alternative to the all too common commodity types in today's market.

Built with stainless steel exteriors and anodized aluminum interiors, their heavy duty cabinet construction promises years of useful service. Truly front breathing, their design allows for "zero-clearance" installation. As a result they can be placed right up against the backwall and alongside other kitchen equipment, saving valuable floor space.

Additionally, they offer a wide range of optional accessories to choose from, and are ideal for use with many different type applications.

Standard Product Features

- Stainless Steel Exterior Top, Sides & Doors
- Anodized Aluminum Interior
- Front Breathing Self-Contained Refrigeration System
- Environmentally Friendly R-134a Refrigerant
- Self-Closing Stainless Steel Doors With Stay Open Feature At 105 Degrees
- Anodized Aluminum Interior Door Liner
- Interior Mounted Thermometer
- Two (2) Powder Coated Shelves Per Door, Mounted On Pilasters
- Automatic Non-Electric Condensate Evaporator
- Magnetic Snap-In Door Gaskets
- 8' Cord & Plug Attached
- Set of Four (4) 6" High Adjustable Legs (6 for models UHT60 & ULT60)
- One Year Parts And Labor Warranty
- Five Year Compressor Warranty

Optional Accessory Kits*

- **CASTER 5SET4** (four 6" high casters for 27" & 48" models)
- **CASTER 5SET6** (six 6" high casters for 60" models)
- **CASTER SET4IN** (four 4" high casters for 27" & 48" models)
- **CASTER 60SET3** (six 4" high casters for 60" models)
- **CASTER SET3IN** (four 3-1/2" high casters for 27" & 48" models)
- **CASTER SET4** (six 3-1/2" high casters for 60" models)
- **CASTER SET2IN** (four 2-1/2" high casters for 27" models)
- **SHELF CPW1** (additional shelf for all 27" models)
- **SHELF48 UPPER** (upper shelf for all 48" models)
- **SHELF48 LOWER** (lower shelf for all 48" models)
- **SHELF60 UPPER** (upper shelf for all 60" models)
- **SHELF60 LOWER** (lower shelf for all 60" models)

*All optional accessory kits are shipped separately for field installation.

Factory Installed Options

- Stainless Steel Finished Back
- **CU27TOP BSWO** (22 ga. stainless steel top with 4" backsplash for models UHT27 and ULT27)
- **CU48TOP BSWO** (22 ga. stainless steel top with 4" backsplash for models UHT48 and ULT48)
- **CU60TOP BSWO** (22 ga. stainless steel top with 4" backsplash for models UHT60 and ULT60)
- Other Door Hingsings

Other Options

- Two Year Service/Labor Warranty Available



Please visit www.energystar.gov to view the most up-to-date product listing and performance data.



Listed by Underwriters Laboratories Inc., to U.S. and Canadian safety standards and and NSF International in accordance with ANSI/NSF7.

Approval: _____



TRAUlsen
4401 BLUE MOUND RD.
PHONE 1 (800) 825-8220
Website: www.traulsen.com

FT. WORTH, TX 76106
FAX-MKTG. 1 (817) 624-4302

Project

Quantity

Item #

Model Specified:

CSI Section 11400

Elevation UHT27 & ULT27

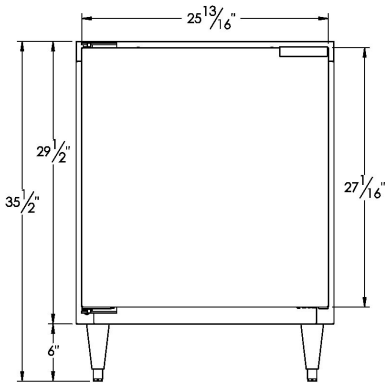

Elevation UHT48 & ULT48

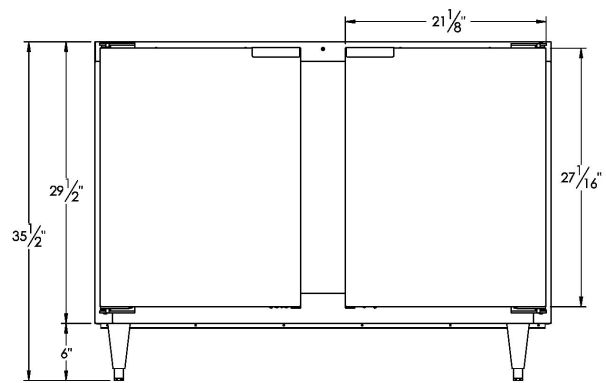

Plan UHT27 & ULT27

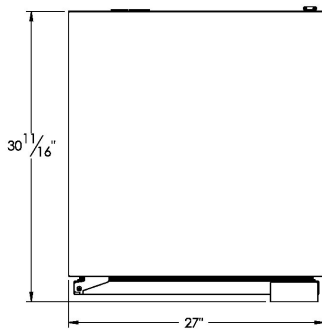

Plan UHT48 & ULT48

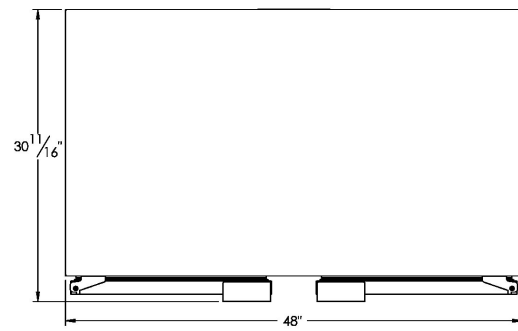

Section UHT27 & ULT27

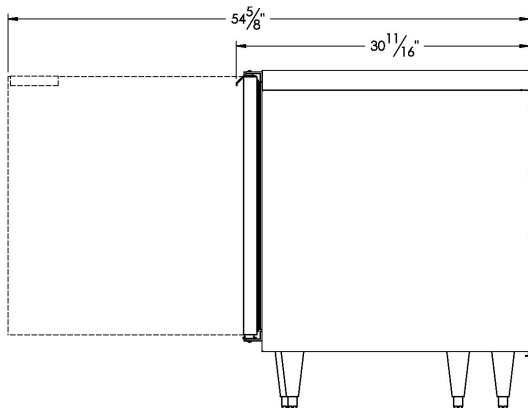

Section UHT48 & ULT48

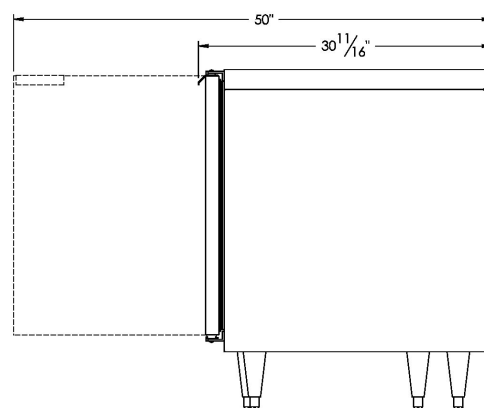

TRAULSEN
4401 BLUE MOUND RD.
PHONE 1 (800) 825-8220
Website: www.traulsen.com

FT. WORTH, TX 76106
FAX-MKTG. 1 (817) 624-4302

Traulsen

Project	Quantity	Item #
Model Specified:		CSI Section 11400

Elevation UHT60 & ULT60

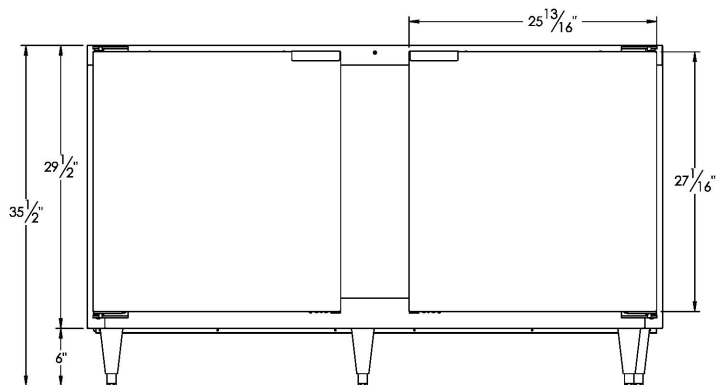

Plan UHT60 & ULT60

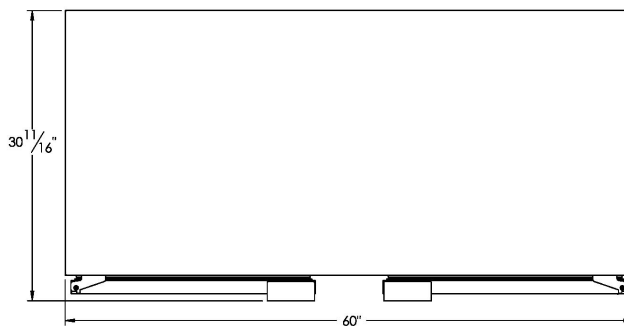

Section UHT60 & ULT60

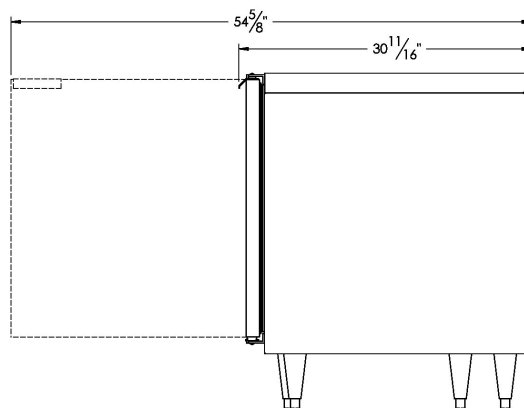

TRAULSEN
 4401 BLUE MOUND RD.
 PHONE 1 (800) 825-8220
 Website: www.traulsen.com

FT. WORTH, TX 76106
 FAX-MKTG. 1 (817) 624-4302

Project	Quantity	Item #
Model Specified:		CSI Section 11400

Specifications

Construction, Hardware and Insulation

Cabinet exterior front, one piece sides, and doors are constructed of 22 gauge stainless steel. Cabinet interior and door liners are constructed of anodized aluminum. The exterior cabinet back and bottom are constructed of galvanized steel.

Door self close at less than 90 degrees and also include a stay open feature at 105 degrees. Easily removable for cleaning, vinyl magnetic door gasket assures tight door seal.

Both the cabinet and door(s) are insulated with an average of 2" thick high density, non-CFC, foamed in place polyurethane.

Refrigeration System

A balanced, rear mounted, front breathing, self-contained refrigeration system using R-134a (refrigerators) or R-404A (freezers) refrigerant is provided. It features a capillary tube metering device, air-cooled hermetic compressor, a forced air evaporator coil and a non-electric condensate evaporator. An 8' cord and plug is provided. Standard operating temperature for refrigerator models is 34 to 38°F, and for freezers models is 0 to -5°F.

Interior

Standard interior arrangements include two (2) powder coated wire shelves per door, mounted on pilasters. These are adjustable in 1/2" increments, allowing for a minimum of 1-1/2" spacing between shelves.

Warranties

Both a one year parts and labor warranty and a five year compressor warranty (self-contained models only) are provided standard. An optional 2nd year extended parts and labor warranty is also available.

DIMENSIONAL DATA	UHT27	UHT48	UHT60	ULT27	ULT48	ULT60
Refrigerator or Freezer	Refrigerator	Refrigerator	Refrigerator	Freezer	Freezer	Freezer
Net capacity cu. ft.	7.1	13.1	16.7	7.1	13.1	16.7
Length - overall in.	27	48	60	27	48	60
Depth - overall in.	30 ¹¹ / ₁₆	30 ¹¹ / ₁₆	30 ¹¹ / ₁₆	30 ¹¹ / ₁₆	30 ¹¹ / ₁₆	30 ¹¹ / ₁₆
Depth - with door open 90°	54 ⁵ / ₈	50	54 ⁵ / ₈	54 ⁵ / ₈	50	54 ⁵ / ₈
Clear door height in.	24 ¹ / ₈	24 ¹ / ₈	24 ¹ / ₈	24 ¹ / ₈	24 ¹ / ₈	24 ¹ / ₈
Clear door width in.	22 ³ / ₄	18 ¹ / ₄	22 ³ / ₄	22 ³ / ₄	18 ¹ / ₄	22 ³ / ₄
Height - overall on 6" legs in.	35 ¹ / ₂	35 ¹ / ₂	35 ¹ / ₂	35 ¹ / ₂	35 ¹ / ₂	35 ¹ / ₂
Number of shelves - total	2	4	4	2	4	4
Shelf area sq. ft.	4.88	10.3	13.2	4.88	10.3	13.2
ELECTRICAL DATA						
Voltage	115/60/1	115/60/1	115/60/1	115/60/1	115/60/1	115/60/1
Full Load Amperes	3.3	5.7	5.7	6.3	7.7	8.7
REFRIGERATION DATA						
Refrigerant	R-134a	R-134a	R-134a	R-404A	R-404A	R-404A
BTU/HR - H.P. ¹	889 (1/8 HP)	1869 (1/4 HP)	1869 (1/4 HP)	1450 (1/3 HP)	1610 (1/3 HP)	2160 (1/2 HP)
SHIPPING DATA						
Length - Crated in.	44	63 ¹ / ₂	75 ¹ / ₂	44	63 ¹ / ₂	75 ¹ / ₂
Depth - Crated in.	44 ¹ / ₄	44 ¹ / ₄	44 ¹ / ₄	44 ¹ / ₄	44 ¹ / ₄	44 ¹ / ₄
Height - Crated in.	46 ³ / ₄	46 ³ / ₄	46 ³ / ₄	46 ³ / ₄	46 ³ / ₄	46 ³ / ₄
Volume - Crated cu. ft.	53	76	90	53	76	90
Net Wt. lbs.	250	265	355	260	275	365
Gross Wt. lbs.	275	290	380	285	300	390

NOTES

1= Based on a 90 degree F ambient and 20 degree F evaporator.



Equipped With One NEMA 5-15 P Plug

NOTE: When ordering please specify: Voltage, Hinging, Optional Accessories and any additional warranties.

Continued product development may necessitate specification changes without notice.
Part No. TR35819 (revised 4/10)

TRAUlsen
4401 BLUE MOUND RD.
PHONE 1 (800) 825-8220
Website: www.traulsen.com

FT. WORTH, TX 76106
FAX-MKTG. 1 (817) 624-4302

